

505  
P 81









# Popular Science Monthly

---

Volume 89  
July-December, 1916

---

Modern Publishing Company  
239 Fourth Avenue  
New York

24268

This volume contains:

960 pages

1323 articles

2153 pictures



Q  
1-  
F87  
V.89

Copyright, 1916, by  
MODERN PUBLISHING COMPANY

*All rights reserved*







	Page
An Extension Reel for Electric Lamps	843
An Electrically Heated Foot-Board for the Policeman	883
Determining the Intensity of Illumination by a New Measuring System	913
Making an Electrically Heated Soldering Iron	947
An Electric Burglar Alarm Attached to a Door-Lock	947
A Dead End Switch of the Multiple-Point Type	948
A Salt Water Polarity Indicator Made from a Burned-Out Fuse	952
An Electrically-Operated Recording Weather Vane	952
Operating Furnace Checks and Drafts by Electricity	954

HOUSEKEEPING MADE EASY

An Improved Vegetable Slicer	107
Housekeeping Made Easy	111
Why Young Girls Don't Leave Home	232-233
Keeping Food Without Ice	293
Make Your Own Lazy-Betty	299
Improving a Towel-Roller	301
String Holder and Cutter	306
Handy Folding Kitchen Tables	309
Housekeeping Made Easy	372-373
Cleaning Gloves Economically with Benzine	409
Converting Sun-Parlor into Bedroom	427
A Towel Holder	458
A Convenient Shoe-Rack	459
An Easily Constructed Holder for the Broom	468
A Screen Door-check	477
How Do You Sit?	551
Bathing in Your Trunk	557
Housekeeping Made Easy	558-559
Using the Steam Radiator to Remove Wall-Paper	564
The Electric Scrub-Woman—Brainless but Efficient	566
Trundling Your Washing-Machine on Wheels	566
Why Isn't This Used Instead of Hooks and Eyes?	575
Repairing Worn Wheels of a Carpet-Sweeper	601
A Scheme for Keeping Pictures Hanging Straight	608
A Clothes-Rack for Use Indoors and Outdoors	603
Protecting the Gas Range with a Wind-Shield	618
Turning the Stationary Tub into an Electric Washing Machine	647
Electric Ranges Are Becoming Popular	681
Housekeeping Made Easy	690-691
Water-Heating Garbage Burner	698
Doing the Family Washing in Your Rocking Chair	738
The "Permanent Wave" of a Woman's Hair and Its Secret	743
Reducing the Furnace Man to a Mere Push-Button	751
A Comfortable Electric Foot-Warmer Pad	752
A Foot-Warmer Attachment for a Radiator	761
How to Straighten the Crooked Straws of a Broom	775
A Heater for Use Over the Flame of a Gas Jet or Kerosene Lamp	855
Housekeeping Made Easy	858-859
Removing Old Starch from Clothes by a Malt Extract Bath	913

HOW THE WAR IS BEING FOUGHT

War Pictures	32-47
When the Fighting Man Dreams	53
Locating Guns by Delicate Earthquake-Detectors	178
Submarine Destroyers	180
War Pictures	208-223
Experimenting with Liquid Fire	208
Firing with Heavy Artillery at an Enemy You Can't See	226
War Pictures	336-351
The Wastage of Flying Machines in the Great War	377
"Shooting" a Photograph with a Pistol-Camera	408
A Modern War Relic	425
Fitting Penholders to Crippled Hands	435
War Pictures	487-495
How London Cares for Soldiers' Babies	502
How the Firing of Heavy Guns Affects Animals	576
Detecting Enemy Submarines from a Ship's Look-Out	579

INVENTIONS TO MAKE LIFE EASY

Adjustable Kettle-Cover	113
Hammer for One-Armed Man	113
Handling the Cord of Electric Irons	113
At Last! A Lock for Slipping Rubbers	113
A New Way of Directing the Breeze of a Fan	113
A Salt-Shaker Which Will Not Clog	113

	Page
An Adjustable Golf-Tee Board	114
Combined Penholder and Blotter	114
Saw Cuts Square Hole	114
Semaphore Signals for Automobiles	114
Skinning the Slippery Eel	114
Why Fall Down in Your Bath-Tub?	114
At Last! A Machine Which Irons Skirts Without a Murmur	184
Keeping Cool with a Fan Driven by a Hot-Air Engine	246
A Fancy Shoe-Lace Cover	270
A Heater for the Parlor Lamp	270
Pipe Loaded from Stem	270
Automatic Roller Bearing	270
A Spoon That Can't Slip	270
Spout Attachment for Bottles	270
Aluminum Billiard Cue	271
Automobiling with a Bicycle	271
Beating the Dentist to It	271
A Cure for Butter Fingers	271
Facilitating Speed in Writing	271
A Swatter for High-Fliers	271
Shoes of Esparto-Straw which Outwear Leather	375
Escaping the Barber's Fingers	432
Collapsible Tooth-Brush Case	432
Keeping the Baby's Bottle Just Right	432
A Pipe with a Cleaning Wick	432
A Detachable Massage Brush	432
A Mechanical Oyster-Opener	432
Holding Asparagus in the Can	433
Adding Dignity to Condensed Milk Cans	433
Putting Exhaust Gases to Work	433
Reducing Eye-Strain	433
Handle and Cover for Milk Bottles	433

MECHANICAL ENGINEERING

Revolving Portable Elevator	165
Coaling a Liner with an Elevator	206
A Giant Grinder Which Goes to Its Work	240
How Heat Is Measured with the Eye	330
New Kind of Lawn Sprinkler	332
Loading Guns by Pneumatic Tube	334
The Paving Blocks of Paris	352
Sorting and Packing Apples by Machinery	363
A Low Water Alarm for Boilers	370
Locomotive Runs Three Hours on Charge from Boiler Plant	370
A Typewriter Made Especially for the One-Armed	371
A Locomotive that Burns Pulverized Coal	376
Keeping Watch on the Chimney	378
The "Spinning Wheel" Gun	397
One of the Pranks of the San Francisco Earthquake	416
Why Not Make Rain Work? A Chance for a Rain Motor	419
Smoothing Sidewalks by Machine	426
The Preeminence of American Inventive Ingenuity	427
Belt Shifter Protects Workmen	434
A Curious Clock Built on a New Principle	511
Putting Wheels Under Workmen	514
Harnessing the Sun	515
A Machine-Shop in a Diving-Bell	577
Preventing Ships from Rolling with Fly Wheels	591
Cleaning Crown Bottle-Corks in a Portable Hopper	592
A High-Speed Bit That Bores Without Choking	647
Let a Puff of Air Do It	664
Air Is Stronger Than Arms	665
Dummies That Dance and Play	666
Dual Power, Portable Hoisting Machine of Compact Design	674
A Modern "Newspaper Maker"	676
A Simple Instrument Which Measures the Height of a Tree	696
To Protect the Fingers of the Woodworker	705
Combined Velocipede and Hobby-Horse	715
Felling Trees Automatically with a Mechanical Swordfish	715
A Water Curtain Used on a Heating Furnace	726
The Inventor of the Steam Engine Was Interested in Gim-Cracks	739
Saving Gold and Silver on the Vacuum-Cleaner Principle	750
This Ice-Cutting Machine Takes the Place of Eight Horse-Teams	810
Preventing Boiler Troubles by Mechanical Cleaning	811
An Adjustable Steering Device for the Tractor	832
A Mechanical Printer for Fac-Simile Letters	856

	Page		Page
A Machine for Cleaning Ceilings	841	The Great Hoodoo Temple	655
An Unusually Intelligent Slot Machine	842	When Rain, Thunder and Lightning Start Toward the Earth at the Same Time	674
Mechanical Kinks	876-877	The Deepest Known Place in the Ocean	683
The Giant Destroyer of the Future	897	Nature and Not Cannons the Cause of Rainfall	744
<b>MEDICINE, SURGERY AND HYGIENE</b>			
What X-Rays Can Do for Your Teeth	20	Queer Denizens of the Deep	822
Killing Vermin with Gas	119	Is This the Origin of Forcible Feeding?	823
Modern Methods for Exterminating the Mosquito	166	As a Packer Let Us Recommend Mother Nature	826
Soldier of Today Better Off Amid New Horrors	184	Not Candy but Moth and Butterfly Eggs	827
Eradication of Weeds Will Prevent Hay-Fever	238	Iridescent Fish-Eggs for Table Decoration	875
How to Get Thin and Fool the Family	240	"Great Fleas Have Little Fleas Upon Their Backs to Bite 'Em"	875
Chinese Doctors and Their Ways	243	Why Does Sap Rise Against Gravity?	886
War Will Diminish Stature and Vigor of Human Race	252	<b>PHOTOGRAPHY AND MOTION-PICTURES</b>	
If Your Hand Is Too Small—Stretch It	361	As Easily Handled as a Rifle	77
Exterminating Mosquitoes	367	Seeing the Unseen	89
The Latest Answer to "What Is a Cold?"	374	Photography in Natural Colors	102
Fighting Infantile Paralysis	399	A Dark-Room Lamp	120
Taking a Census of Occupational Diseases	486	How to Photograph Wild Animals	136
A Mechanical Masseur That Works Off Fat	486	Catastrophes by the Foot	163
Have You Perchance a "Vocational Disease?"	519	Comic Insect Photography	191
Where Beautiful Hair Is Not a Crowning Glory	528	A Photographic Eye for the Airman	202
Eliminating One of the Tortures of the Dentist's Chair	534	Washington Monument as a Motion-Picture Screen	354
How Do You Sit?	551	Staging the Celluloid Thriller	401
Sampling the Drinks for an Entire Large City	556	An X-Ray Tilting Table	407
Steam Yourself and Drive Away Your Ills	575	"Shooting" a Photograph with a Pistol-Camera	408
Testing the Air-Fighter's Nerve	580	Pendulum for the Dark Room	450
Mechanical Lungs for the Fire-Fighter	587	An Improvised Reflecting-Camera	460
Some Peculiarities of Eye-Glasses	616	Novel Device for Copying Pictures	460
More Light on the Occupant of the Dentist's Chair	626	Home-Made Camera Shutter	461
A Simple Electrical Device for Purifying Water	638	A Useful Trimming Board	461
Measuring the Horsepower of That Baby of Yours	644	Simple Test of Shutter Speed	461
Exercising Machines for Wounded Soldiers	653	Cheap Photographic Changing Box	473
A Humane Method of Destroying Horses	684	Wild Animals That Photograph Themselves	483
New Apparatus for Setting Broken Limbs	684	Preserving the Orchestra Leader's Art	535
Using the X-Ray on Animals	696	Drying Negatives by Heat from a Kerosene Lamp	602
Defense for the Ears Against Noise and Shock	707	A Photographic Printing-Box for Use with Electric Current	603
Resuscitating the Drowned	744	Saving the Picture Show with a New Rheostat	633
Lifting Invalids with a Minimum of Discomfort	746	Using the X-Ray on Animals	696
Why Do We Grow Bald?	812	A Daylight Developing-Tank	716
New Cures at the Royal Baths in England	818	Boring Straight by Photography	720
Making Air Fit to Breathe	833	Making the Music Fit the Movie	733
Medicinal Cartridge-Belt for Peaceful Expeditions	849	"Shooting" Birds with a Camera	741
A Device Invented by a Blind Doctor to Enable Himself to Write Letters	849	Eight Pictures on One Plate	856
Humankind's Bent Twigs	850	Photographic Printing Masks Easily Made	931
Corns—What They Are and Why They Hurt	857	A Dark-Room Lamp to Be Used Under a Glass Tray	934
The Medicinal and Hygienic Virtues of the Lemon	863	<b>PICTURE PAGES</b>	
The Cancer Problem	873	A Tree Like the Rock Which Moses Smote	651
Friction Tape Used for Plaster Strips	925	Exercising Machines for Wounded Soldiers	653
<b>MINING</b>			
Steaming Frozen Ground for Gold	687	A Fish that Builds a Nest Like a Bird	654
Coal-Mine Fatalities in the United States During the Year 1915	696	The Great Hoodoo Temple	655
<b>NATURAL SCIENCE</b>			
How Fish Jump 100-Foot Dams	364	Where Germany Gets Her Basalt Paving Blocks	656
Borrowing the Night Lamps of the Fireflies	365	Relics of Indian Superstition	658
Why Whiskers Continue to Be in Style for Cats	369	Curious Clocks of Paris	659
Fishing in Guiana with the Bow and Arrow	385	A Great Collapsible Field Periscope	660
When Manicuring Nails Is a Dangerous Job	410	Watching a Battle Through a Super-Periscope	661
Rocking Stones and Their Romantic Story	413	The Largest Duck Farm in the World	652-653
Even the Hornets Have New Ideas Sometimes	417	Let a Puff of Air Do It	664
Exploiting the Island of Laysan for the Eggs of the Albatross	428-429	Air Is Stronger Than Human Arms	665
The Reason Why We Have Two Eyes	434	A Modern "Newspaper Maker"	676
Insect Grotesques	496-497	Using the Telephone on the Rifle Range	682
When Nature Plays the Architect	498-499	Scenes in Alaska	814-815
Freak Trees. How Did They Happen?	512	Marooned by the Tide at West Australia	816
A Curious Egg Shaped Like a Dumb-Bell	513	Trapshooting in the Navy	817
A Slab of Sandstone Seventy-Five Million Years Old	513	New Cures at the Royal Baths in England	818
Would You Recognize the Ear-Bone of a Whale If You Saw One?	513	Tropical "Snow Drifts" of Cheesecloth	819
Why the Color of Sea Water Is Blue or Green	522	Food Freaks	820-821
Crossing Dangerous Rivers with Goat-skin Floats	528	Queer Denizens of the Deep	822
A Magician Among the Fishes	562	Is This the Origin of Forcible Feeding?	823
The Strange Vegetable Sheep of Peru	563	Fighting Weapons of Seven Warring Powers	824
Why You Hear Well on a Clear, Frosty Night	646	Aeroplane Art of To-day	825
Weather Bureau Duties Overlooked in Criticizing the Weather Prophet	647	As a Packer Let Us Recommend Mother Nature	826
The Tree Warfare Against Rocks	650	Not Candy but Moth and Butterfly Eggs	827
The Traveler's Tree	651	Japanese Ivory Carvers Use Modern Tools	828
A Fish That Builds a Nest Like a Bird	654	<b>PRACTICAL WORKERS DEPARTMENT</b>	
		How to Make an Efficient Boiler-Patch	117
		An Easily Made Mercurial Barometer	118
		A Handy One-Drop Oil	120
		A Non-Spillable Funnel	120
		Rubbing in the Lathe	120
		An All-Steel Screwdriver	121
		A Buck-Saw Attachment	121

	Page		Page
How to Etch Glass	121	How to Make a Toy Zeppelin	313
Bonding Joists to Brick Walls	122	Putting New Life in Chisel Handles	314
A Drainage Kink	122	A Handy Bunsen Burner	315
Emergency Control of Motor	122	How to Make a Clevis Lock	315
A Screwdriver Handle	122	A Simple Overflow Alarm	315
Replacing Automobile Piston-Rings	123	An Alarm Bell for Chemists	316
Steam as a Carbon Remover	123	Getting Iron Scraps Out of Deep Holes	316
A Gasoline Tank Gage	124	Rope and a Lever as a Pipe Wrench	316
Simple Cure for Misfiring at Low Engine Speeds	125	A Safety-Holder for Hatpins	316
Building an Oil Reservoir	126	Taking the Yellow Out of Rubber	316
Emptying a Bottle	126	What Home Builders Really Want	317
One Geared Motor Serves Two Drives	126	Boring Cylinders with a Lathe	403
A Pocket-Clip for Pencils	126	Measuring Ten Thousandths of an Inch	436
An Emergency Fountain Pen	130	Iceless Cooker and Refrigerator	456
Making a Two-Fuse Switchblock	130	A Typewriter Desk Made from a Kitchen Table	457
Converting a Key-Socket into a Pull-Socket	136	A Simple and Convenient Receptacle for Matches	457
Making a Washing Machine from a Barrel	147	A Home-Made Fire Extinguisher	458
A Package Tie Made of Tape	147	A Towel Holder	458
Making a Lawn Chair	148	The Strap as a Jar Opener	458
How to Make a Sewing-Screen	149	How to Calculate Distances	459
Fitting Windows with Weights	150	A Convenient Shoe-Rack	459
How to Remove Iodine Stains	150	An Improved Vacuum Bottle	462
Building a Poultry House with a Skylight	151	Facilitates Boiling Point	462
Some Curtain Suggestions	151	Using Waterproof Lutes	462
A Clothes-Line Prop that Will Not Drop or Slip	152	How to Safeguard Mail Against Meddlers	465
A Hoop with a Guiding Hub	152	A Substantial Home-Made Jack	465
How to Pack Mirrors to Prevent Breaking	152	A Case for Miniature Lamps	465
Wood Blocks for Flooring	152	Making a Wood-Turning Lathe	466
Finding the Right-Sized Nail	153	A Bottle Pocket Lamp	467
An Improved Roller-Towel	153	Correcting Pliers which Bind	468
Improving a Kitchen Knife	153	An Easily Constructed Holder for the Broom	468
Let Your Ice-Cream Freeze While Motoring	153	A Weed Destroyer from a Spoon and Broom-Handle	468
Concealed Ventilation	154	A Child's Morris Chair	469
A Home-Made Table-Top Varnish	154	An Efficient Tin Pump	470
Removing Heat Spots from a Table	154	Scale Reading Calipers	471
To Screen Doors and Windows	154	Soldering Iron for Light Work	471
A Merry-Go-Round Swing	155	Making a Driving-Box Lifter	471
How to Make a Practical Gas-Range Lighter	156	Guide Lines for Lettering	471
Making the Cellarway Serve Two Purposes	156	Getting a Line on Bidly	472
A Back-Saving Refrigerator	157	Boiling Water by Cooling It	472
For Cleaning Leather Upholstery	157	To Find Your Depth	472
How to Make a Door-Mat from Old Rope-Ends	157	An Automatic Faucet for Tanks	473
Renovating the Lawn	157	The Use of Jigs and Fixtures	474
An Opposed Cylinder Steam Engine	289	A Portable Colony Poultry House	476
A Pulley Made from Wax and Wire	292	A Screen Door-Check	477
Making a Space with a Chain Line	292	Cooling a Ship's Laundry	477
Keeping Food Without Ice	293	How to Drill Holes Quickly in Wood	477
Stopping a Drawing Board	293	Making a Plate-Glass Drill	478
Straightening Warped Boards	293	Coloring of Copper	478
Convex Milling Cutters	294	A Handy Spacing Scheme	478
Jig for Drilling Holes in Peripheries	294	A Cozy Southern Farmhouse	479
Measuring Bucket for Flowing Water	294	To Improve Machinist's Cement	480
Making a Bomb Thrower for Sham Battles	295	Mooring Hook Locks Itself to Eyebolt	536
To Compress a Coil-Spring	296	How to Make an Alcohol Lamp and Blow-Torch	593
The Whistling Bicycle Wheel	297	from an Oil-Can	593
An Adjustable Tap Wrench	298	Making Automobile Wheels Track Correctly	593
Hoisting Timbers Rapidly	298	Two Good Calking Compounds for Boats	593
Three Oil-Proof Lutes	298	Accelerating the Cooling Water Circulation	594
Make Your Own Lazy-Betty	299	A Pencil Sharpener with an Adjustable Blade	594
A Simple Home-Made Milking Stool	299	A Quick Method of Repairing a Broken Die	594
Replacing Pistons by Simple Means	300	Equipment for the Home Worker	595
Universal Bench-Stop	300	To Make a Combined Drawing Table and Stand	598
Improving a Towel-Roller	301	How to Protect the Surface of an Enameled Road-Sign	599
A Manager's Desk File	301	A Spanish Windlass Made from Two Broomsticks	599
Tightening Wire on Knobs	301	Finding Your Bearings at Night Without a Compass	600
Drilling Square Holes	302	An Ingenious Attachment for a Door-Lock	600
A Remedy for Jarring Bottles	302	To Make a Sanitary Cap for the Milk Bottle	600
How to Make a Sleeping Hammock	303	A Bottle-Stopper of Glass and Rubber	601
Determining Brake Horsepower	303	How to Lighten the Finish on Woodwork	601
Preventing Carriage Bolts from Turning	303	Repairing Worn Wheels of a Carpet-Sweeper	601
A Celluloid Flashlight	305	Making a Scrap-Book Out of Old Ledger Covers	602
How to Make an Oil-Filter	306	A Thumb-Tack Gage for a Paper-Cutting Board	603
String Holder and Cutter	306	A Scheme for Keeping Pictures Hanging Straight	603
Attachment for Oxy-Acetylene Torch	307	Removing and Applying Valve-Stem Guides by Pressure	604
Turning on Lathe with Calipers	307	A Simple Tracing Method for Electrical Draftsmen	606
A Home-Made Scoop	308	A Bottle-Stopper Which Controls the Outpour	607
Protecting the Painter from Paint	308	A Gage Which Tells the Amount of Moisture in Wood	607
Fiber Disk Cutter	309	Mending Picture Frames with Laundry Snap	607
Handy Folding Kitchen Tables	309	A Clothes-Rack for Use Indoors and Outdoors	608
To Repeat Drawings	309	An Easily Made Bathroom Cabinet and Medicine Chest	608
A Cheap Surveying Instrument	310	A Blacksmith's Hand-Blow Made of Wood	609
To Re-Silver Old Mirrors	310	To Convert a Pair of Shoes into Slippers	609
Temporary Pole-Steps of Spikes	310	Four Good Recipes for Acid-Proof Cements	609
How to Keep Rope from Raveling	311		
Regulating Shower-Bath Water	311		
A Cheap Fly-Catcher	312		
An Easily Constructed Fly-Trap	312		

	Page		Page
A Draftsman's Inkstand Which Will Not Overturn	610	Caring for Storage Batteries in Automobiles	792
Improved Method for Decorative Glass Blowing	610	Discarded Type-Cases in the Amateur's Shop	792
Renovating Nickel Plate with Tinfoil and Solder	610	A New Method of Reviving Old Dry Batteries	793
What to Do with Small Pieces of Bath Sponge	610	Amateur Trench Electricians	794
Keeping Rats Out of the Corn-Crib	611	Avoiding Clouded and Grimy Ceilings	796
Adjustable Overshoes to Prevent Horses from Slipping	612	To Prevent Asphaltum in Cans from Evaporating	796
An Easily Constructed Support for a Trap-Door	612	The Construction of a Small Concrete Corn-Crib	800
To Lengthen a Shot-Chain on a Pull Socket	613	Utilizing the Waste from Welsbach Mantles	841
To Make a Dry Battery Having Lasting Qualities	613	A Quick Method for Measuring Light	848
A Weight and Pulley to Adjust Flexible Lamp Cords	613	Making Decorative Butterflies in Sheet-Copper	921
Annealing Brass Pipe for Bending	614	Repairing Automobile Tires to Prevent Bulky Places	921
Two Types of Inexpensive Depth Gages	614	Grinding Automobile Engine-Valve Seats Set in a Sleeve	922
How to Make a Mallet from a Piece of Broomstick	615	Making Flexible Mirrors from Tinfoil on Celluloid	922
Operating the Oil-Pump of an Automobile by Valve Action	615	A Water-Barrel Elevator in a Well	923
How to Make Your Watch-Dial Luminous	616	Secret of Success in Filing Cross-Cut Saws	923
Making a Polisher for Table Cutlery from a Piece of Carpet	616	A Toy Bank of Wood Made Without Nails	924
Benches for Electrical and Mechanical Machinery	617	Making a Wood-Burning Heater for the Home	924
Protecting the Gas Range with a Wind-Shield	618	Making the Vibrations of the Voice Draw Designs	925
A Simple Method of Filing Checks and Receipts	618	Friction Tape Used for Plaster Strips	925
Utilizing an Old-Fashioned Flat-Iron as an Anvil	618	A Home-Made Heating Arrangement	926
A Canteen Made by a Junior Boy Scout	619	How to Make a Pendulum Swing Easily	926
The Indian's Method of Tethering a Horse	619	Starting an Automobile When One Rear Wheel Is on Ice	926
Keeping Your Ties in Good Condition	619	Lifted Tread Sections in Making Automobile Tire Repairs	926
A Simple Way of Making a Canoe Unsinkable	619	A Motorcycle Bob	927
A Novel Experiment with a Lamp-Bulb	620	Filtering Gasoline Through Chamois, Dangerous	930
Prolonging the Usefulness of a Saucepan Cover	620	Photographic Printing Masks Easily Made	931
Removing Old Putty from a Window-Pane	625	Making Extended Index Tabs for Books	932
A Tool for Fishing Wires Through Small Openings	626	Removing Collar on Change-Gear Spindle of Lathe	932
Magnet-Power of Toy Automobiles for Window Display	626	Changing a Boy's Handcar Into a Mechanically Propelled Sled	933
A Switch Operated by Pressure on a Footboard	632	Removing a Bushing from a Blind Hole	933
A Magneto Made from Two Discarded Cannons	644	A Fountain Attachment for Ordinary Pens	934
Charging Weak Magnetos of Weak Automobiles	672	A Dark-Room Lamp Used Under a Glass Tray	934
Making the Water from a Faucet Vibrate Fifteen Times a Second	750	A Sanitary Home-Made Tooth-Brush Holder	934
Field Photograph Kit for the Use of the Artillery	759	Substitutes for the Ordinary Carpenter's Levels	935
A Show-Window Advertising Device Operated by Gas Bubbles	760	A Good Substitute for a Solid Round Belt	935
How Electricity and Temperature Affect a Watch	760	To Prevent Steel from Rusting After Soldering	936
A Foot-Warmer Attachment for a Radiator	761	Luggage-Carrier to Attach to Your Bicycle	936
A Combination Tool with Many Uses	762	Automobile Carbureter for Heavy Fuel Oils	936
Marking Points to Bore Holes for Dowels	762	How to Make a New Bureau from an Old One	937
Painting a Ladderless Standpipe	762	A Revolving Washer Made from an Old Rim	937
Making a Serviceable Fireless Cooker	763	A Quickly Made Silver-Plating Powder	937
To Keep the Water in the Aquarium Clean	763	Replacing a Knob on an Aluminum Kettle Top	938
Loosening a Wood Screw to Draw It Easily	764	Grooves Necessary in Giant Motor-Truck Tires	938
Transforming a Wheelbarrow into a Fantastic Toy	764	Making Screws Hold in the End Grain of Wood	938
Constructing a Sidecar for a Bicycle or Motorcycle	765	Adjusting a Storm Sash from the Inside of a House	938
A Fire and Water-Proof Cement for Mending Stone Fire-Brick	766	A Snow Shovel Keeps the Snow from Sticking	939
An Improved Grinder for Gas-Engine Valves	766	Eliminating Trouble with Toilet Flush-Tanks	940
A Revolving Telephone Index on the Transmitter	766	A Makeshift Syphon	940
How to Build a Stereopticon	767	Utilizing the Waste Heat from an Open Fireplace	940
A Substitute Blow Torch for Soldering Joints	772	Aluminum Alloy for Patterns and Core Boxes	940
To Make a Storm Vestibule on a Veranda	772	Building a Speedy Ice-Yacht	941
An Easy Method for Drilling Holes in Glass	774	Preventing Exposed Water-Pipes from Freezing	945
An Emergency Clothes Hanger for the Traveler	774	How to Handle Sulphuric Acid with Safety	945
Utilizing a Piano Stool as a Typewriter Stand	774	Milk as a Lubricant for Drilling in Copper	946
An Automatic Cleaner for Bicycle Hubs	775	Lubricating the Working Joints of a Pocket Knife	946
A Heat Deflector for a Hot Air Register	775	A Puller to Remove Steering Wheels on Automobiles	946
How to Straighten the Crooked Straws of a Broom	775	Compressing Leaf Springs to Bolt Them	946
An Improved Force-Filter Which Is Easily Cleaned	775	Intensifying Magnetic Fields for an Automobile Dynamo	948
A Scheme for Soldering Metals Difficult to Join	775	Plans of a Small Modern Dairy Barn	960
Plane Blade Clamp and Emery-Wheel Guide	776		
A Hollowed Chamber of Horrors	777	RADIO COMMUNICATION	
An Alarm-Clock Dinner Bell for Old Dobbin	779	The Construction of an Improved High-Tension Audion Battery	131
An Experiment with the Static Electricity from Belts	779	Making a Mechanical Interrupter	138
An Automatic Grain-Valve to Prevent Waste	780	A Simple Anchor-Gap	138
Brackets for Double Sheets of Wrapping Paper	780	Temporary Variable Condenser	138
Keeping Roasted Peanuts Hot on a Steam Radiator	780	A Delicate Crystal Detector	139
Making Storm Sashes from Old Shutter-Frames	781	A Lead-in Connector	139
Getting Maximum Service from a Typewriter Ribbon	782	Mounting a Rotary Gap	139
Lubricating Automobile Spring Shackles and Bolts	783	Radio in the Far South	139
A Pocket Flash-Lamp on the Bicycle Handlebar	783	An Unusual Code Letter	140
Estimating the Speed of Passing Automobiles	784	Greater Speed in Wireless Receiving	140
A Practical Pulverizer Made from a Cutter-Bar	784	Receiving Undamped Oscillations	140
De-Sulphating Storage-Battery Plates	787	Compact Condensers	142
Insulated Plier Handles with Fuse Cases	788	The Best Crystal Detectors	143
A Home-Made Flood-Light Projector	788	What Radio Readers Want to Know	145
Making an Alternate Current Buzzer from Old Bell Coils	788	Winners in the Radio Prize Contest	2
		A Wireless Telegraph Transmitter with Two Spark Frequencies	2
		A Booth for Long Distance Receiving	2

	Page		Page
Cardboard Tubes	275	Ten Millions to Save Four Miles	553
How a Compact Molded Condenser Is Built	275	A Danger Signal Which Compels Attention	572
Primary Regulator for the Induction Coil	275	Our First Armored Car	588
Small Radio Stations	275	The Hose Is Mightier Than the Brush	688
Lowering the Decrement	277	A Motor-Wheel for the Railroad Velocipede	742
Lighting Audion Bulbs Cheaply	278	A Locomotive Side-Frame Which Weighs Nearly	
Music by Wireless	278	Seven Tons	829
A Substitute for An Aerial	280	A Wind-Deflecting Lookout Mask for Engineers	832
Telephone Headbands	280	Daylight Lamp Signals	847
A Built-Up Wireless Mast	281	A Device for Adjusting the Ends of Steel Rails	915
A Sending Condenser	282	Transforming a Railroad Water-Tank Into a	
Adjusting Handles	283	Home for Two	919
A New Detector Material	284		
A Good Loose-Coupler Switch	285	SHIPS AND SHIP BUILDING	
Modified Audion Is New Telephone	285	Protecting a Battleship with a Belt of Air	18
Reducing Arcing at Key Contacts	285	How a Steamer's Engine Room Is Ventilated	104
A Quenched Gap with Metal Spacers	286	Charting the Dangers of the Deep	204
Switch Points for Radio Instruments	286	Coaling a Liner with an Elevator	206
What Radio Readers Want to Know	287	The World's Largest Ships' Register	226
A Microphonic Amplifier	437	Pulverized Coal Burners on Our Modern Ocean	
Constructing an Amateur's Aerial	439	Steamships	230
Guying the Mast	442	A Damaged Lock Gate Repaired by Its Own	
A New Tuner Arrangement	445	Water	234
Lepel Improves His System	445	A Venetian Barge in Boston	258
A New Variable Condenser	448	A Guard for Mooring Ropes to Prevent Rats from	
The Quenched Gap	448	Landing	363
A Kick-Back Preventer	448	Tethering the Largest of the Super-Dreadnoughts	381
How to Become a Wireless Operator	449	Milazzo—the Largest Coal Ship in the World	392
Curious Form of Dustproof Detector Cup	452	Cooling a Ship's Laundry	477
A Rotary Adjustment for Coupling	452	Pocket-Flashlight Distress-Signals	520
What Radio Readers Want to Know	453	Piping Oil to Ships at Sea	521
Insulating the Ground Connection in Radio Work	613	A Fog-Stick for Traffic on the Great Lakes	522
An Easily Made Self-Locking Device for Barn-		A Fleet of Indoor Battleships	578
Doors	614	Detecting Enemy Submarines from a Ship's Lock-	
Converting a Plain Zinc-Gap into an Air Blast		Out	579
Spark-Gap	621	Preventing Ships from Rolling with Fly Wheels	592
Strengthening the Static Field of an Amplifier	622	The Thousand-Foot Battleship	670
Overcoming Troubles in a 200-Meter Wave Outfit	623	A Novel Device for Generating Fresh Air in Sub-	
How to Become a Wireless Operator	627	marines	681
Employing Kites to Support an Aerial	630	Telegraphing Through the Ocean	711
A New Spark-Gap for Wireless Telephony	631	Defending America with Motor Torpedo Boats	721
Making a Crystal Detector from Cheap Materials	633	Miniature Magnet-Propelled Ships	737
Wireless Telegraph Stations in the West Indies	633	Discovering Contraband of War	752
Insulating and Decorative Enamel for Electro-		An Endless-Chain Barge Loader	845
Magnets	634	She Lies on Her Side—But They'll Raise Her	880
Best Wavelengths for Certain Distances	635		
What Radio Readers Want to Know	636-637	SPORTS AND PASTIMES	
Converting a Freight Car into a Wireless Station	639	Doing Without the Caddy	12
The Construction of a One-Mile Receiver	789	Golfing at Home	13
How to Become a Wireless Operator	789	Playing Baseball by Machine	57
Making an Inductance Switch for Radio Work	796	The Five-Wheeled Velocipede	64
What Radio Readers Want to Know	797	What Hol 'em The Jitney Yacht	83
Simple Method of Remagnetizing Magnets	799	A "Jakomobile" for Two	100
The Telephone Receiver for Wireless Apparatus	799	What Inventors Are Doing for the Fisherman	105
Experiments with Antennas of Varying Lengths	800	Camp Fire Maxims	115
Making the Aeroplane Generate Its Own Power		Kite Making at Home—II	127
for Wireless	842	How to Make a Practical Gas-Range Lighter	156
Using a Tree as a Mast for a Wireless Station	871	Weightmobile Approaches Perpetual Motion	158
Making an Emergency Aerial for Wireless	948	Leaping Horses That Are Unafraid	168
How to Become a Wireless Operator	949	Another Baseball Game in Disguise	174
Transformer Trouble in Radio Transmitting		An Air-Tight Compartment for Canoe Campers	184
Apparatus	954	Turning Your Racket Press Into a Camp Stool	224
Practicing the Code Without Using a Buzzer	955	The Latest in Golf Clubs	246
How to Take Up the Slack on Your Aerial Wires	955	"Canal Boats" Which Are Real Water-Shoes	257
Canada to Protect Her Parks with Radio Service	955	The First Bird House Exhibit	260
Preventing Interference of Signals by Amplifying	956	Making a Bomb Thrower for Sham Battles	297
A New Direct-Current Transmitter in Radio		The Whistling Bicycle Wheel	313
Communication	957	How to Make a Toy Zeppelin	324
What Radio Readers Want to Know	958	Ferretting out the Secrets of the Golf Ball	324
		A Metal Disk Supplants the Golfer's Tee	325
RAILWAYS		Golfing by the Clock—a New Idea for Golf Courses	325
End-Door Automobile Express Cars	7	What Golfing Sometimes Does to the Feet	325
Driving Railway Spikes with a Motor-Car	26	Making Your Head Behave While You Hit the Ball	325
Hairpin Curves on a Mountain Trolley Line	48	A Paddleless Canoe Propelled by Feet and Hands	326
Beautifying Manhattan's Riverfront	86	Mechanical Joys of Coney Island	394
Minute Men of the Rails	169	Playing Checkers on the Lawn	398
Boy's Road Wagon Is a Real Locomotive	183	Good-By to the Pin-Boys in the Bowling-Alley	409
An Auto Mountain Railway	207	Battle Ball—a New Sport	420
A Western Railroad's Clay Locomotives	242	Getting Ready for the Clay Birds	421
A Railroad Which Fights Its Own Fires	251	A Fascinating Old Sport in a New Dress	436
The Senators' Subway	328	The Trench Marble Game and How It Is Played	455
A Locomotive that Burns Pulverized Coal	376	Decoy Ducks That Quack and Swim	509
Feeling the Way	379	The Old Fondness for Cycling Is Coming Back	514
Railroad Treads for Motor-Trucks	391	Hunting the Mud Pigeon	530
Stopping Trains Automatically	433	Bucking a Wooden Football Line	554
Odd Uses for Railroad Cars	500	Playing Ball with a Revolving Fan as a Target	568
Solving New York's Freight Problem	546	Motoring on Roller-Skates	569

	Page		Page
A Safety-Bicycle for the Timid Fat Man	572	What? Only Three Kinds of Feet?	101
Hunting Destructive Animals in National Forests	576	Mosquitoes on Snow Banks	106
A Warning to Fishermen	590	A Watch-Like Coin-Case	106
The Sidewalk Coaster Becomes an Automobile	592	Fish Hatched in Artesian Basin	107
Training the Football Backler	643	How Indians Graduate from Carlisle	108
Letting the Jumping Rope Record the Jumps	646	Prize Winners of Sam Loyd's Puzzles	112
Suit-Skates for Ice-Skating	646	We Paid Six Dollars for These Two Pictures	161
Scoring Target Practice by Telephone	682	How the Porto Rican Does a Pushing Business	173
Timing Automobile Speed Demons	806	Blending Twelve Grades of Oil Into One	174
A Bicycle Which Won't Let You Lose Your Balance	813	The Perfect Megaphone Shaped Like a Ram's Horn	175
Trapshooting in the Navy	817	The Cockroach Attracts Attention as a Troublemaker	176
Marathoning at Home on a Special Tread Mill	844	Origin of Gas Jets Traced to Woman's Thimble	177
A Dozen Ways of Breaking Your Neck	860	Blow-Pipes of the Borneo Land Dyaks	179
Renovating the Old Golf Ball	894	Throwing a Line of Communications Across a River	179
Johnny Blows Bubbles from His Toy Cigar	894	A Cane to Help the Convalescent Soldier	183
Toys Which Instruct as Well as Entertain	902-905	Wind Cave Excels Mammoth Cave	183
A Buffer to Stop Sprinters in Indoor Sports	932	A Deep-Sea Fish Which Has a Lantern of Its Own	18
Building a Speedy Ice-Yacht	941	A Sailor's Nautical Wind-Wheel	18-
<b>THINGS THAT MAKE FOR EFFICIENCY</b>			
Lighting the Inside of an Oven	16	If We Had Eyes Like Microscopes	190
A Measuring Machine More Sensitive Than a Human Being	16	Trapping English Sparrows for Food	192
A Mechanical Whip	17	How a Snail's Tongue Cleans the Aquarium	193
Hearing Your Men at Work	30	Machines That Smoke Cigars	196
Interchangeable Pressing and Steaming Device for Tailors	30	A Mud Mosaic in the Wake of the Treacherous Colorado	197
Fighting Timber Fires	63	Rocks Composed of Diatom Earth Which Float	197
The Finger Talk of Chicago's Wheat-Pit	81	Fighting the Sand Peril	198
A Wallpaper Remover	119	Device to Hold Covers on Sleeping Child in Crib	200
Modern Dog-Catchers Use Motor-Trucks	176	A Luminous Life-Belt for Rescue at Night	201
Extinguishing an Oil Fire with Carbon-Dioxide Foam	178	Seeing Yourself as the Oil Well Sees You	201
The Motor-Cycle Street-Sweeper	200	Trapping Animals by "Canning" Them	203
A Machine that Stitches Baseball Covers	203	An Old Lamp Used by Rubber Gatherers in Brazilian Jungles	223
A Step-Ladder with an Ambition	230	Where Freckles Come from and Why They Stay	224
Taking the Smoke Out of the Smokiest City	236	Piano and Phonograph Combined	225
The Burglar-Proof Store-Window	238	Surviving Horse-Car Lines in the United States	231
Safety Shaving with a Lamp Attachment	247	Coal-Dust "Mountains" Are Now Repositories of Wealth	235
A Handy Shoe Cabinet for the Whole Family	256	Why a Grasshopper Is Like a Telephone Lineman	241
Cover Lift for Cafeteria Platters	314	Hitting the Trail with a Wheel-Barrow and Determination	241
<b>WAR PROBLEMS IN AMERICA</b>			
The Mine That Hears	3	What Makes the Hair Suddenly Turn Gray?	247
Six Battleships Go Into Reserve	53	Signaling with a Mirror to Men in the Field	252
The Feminine Gender of Preparedness	71	Why You Can See Two Sides of a Thing at the Same Time	252
Throwing a Line of Communications Across a River	179	What's the Good of a Hawk?	254
Pneumatic Gun with a Dynamite Shell	192	Wolves of the Sea That Abound in Cuban Waters	255
The Submarine Blockade Runner	227	Convenient Check Protector	307
Putting the Rookie Through the Mill at Plattsburg	268	A Machine that Cracks Oil-Bearing Nuts Without Crushing Them	326
The Motorcycle Machine-Gun	529	And It Looks so Small on the Map!	329
The Night Eyes of the Coast Artillery	586	Making the Scallops on Plate Glass	330
Our First Armored Car	588	Hungarian Nectar Still in Which Rhubarb Brandy Is Made	333
Introducing Our First Anti-Aircraft Gun	657	Shooting the Chutes to Safety in an Explosion	360
Collecting Money for Belgians by a Sidewalk Chute	668	A Castle Built of Coal to Advertise the Resources of Tennessee	362
The Thousand-Foot Battleship	670	Defying the Action of Fire	366
Defending America with Motor Torpedo Boats	721	A "Soap" Which Is Not Used for Cleansing	371
Saving Men from Sunken Submarines	803	Catering to the Feminine Patrons of the Bootblack	374
Wigwagging with Hand Flags	807	Increasing the Decorative Value of Portieres	374
Taking Care of Automobile Tires at the Front	810	Using the Waste Heat of a Kerosene Lamp	378
A Field Refrigerator for the Camper or Soldier	831	The Sensitive Brazil Nut	381
What Happens in the Stokehold of the Speeding Destroyer	839	A Hand-Made Hand-Played Phonograph	381
The Giant Destroyer of the Future	897	Your Meerschmum Pipe	382
<b>MISCELLANY</b>			
Government Guide-Posts Give Detailed Information for Strangers	7	The Story of Petroleum	383
How Sea Caves Are Made	21	A Rapid Firing Life Saver	389
A Lamb with Two Coats of Wool	21	A Level and Grade Finder on the Periscope Principle	393
A "Shoo-Fly" for a Candy Kitchen	28	Plenty of Room for All Europe	431
A Protecting Holder for an Open-Faced Watch	29	New American Porcelain Utensils a Result of the War	431
Nations Bleed in Peace as Well as in War	62	Spontaneous Combustion	43
The Official City Fly-Catcher of Redlands, California	64	Tracing Magazine Cuts	437
Preparedness Against Bank Burglars	74	Steel Cutlery Which Will Not Rust	483
Experimenting with the Siphon	82	And This in a Mechanical Age!	503
New York Is the World's Luxury Market	83	A Famous Outdoor Organ	510
Nipping Elk to Rid Them of Ticks	88	The Money Value of Two Great Discoveries	511
Ostrich Squab: A New Delicacy	88	Shipping Sugar-Coated Education by the Frankful	511
The Amazing Beetle	94	It Was a Man Dressmaker Who Invented This	514
Insect Carpenters and Masons	95	What Is the Leaning Tower of Pisa Compared with This?	556
Air-Propeller Drives Bicycle	97	Using the Steam Radiator to Remove Wall-Paper	563
Electric Plant Run by an Artesian Well	97	Dropping to Safety from a Fire	567
Straw Raincoats of Japan	101	Pumping Up His Interest in Your Wares	567
		Where the Linnen Collar Started and Who Started It	567
		Removing High Lamp Bulbs	571



	Page		Page
Fanning Yourself with a Rocking-Chair . . . . .	583	Cork Fabric for Featherweight Raincoats . . . . .	813
A Peaceful Looking Hat Which Makes You a Walk- ing Arsenal . . . . .	587	Shooting Soot from Stacks with Blasting Powder . . . . .	831
Expendng Four Tons of Energy in Playing the "Cello" . . . . .	590	A Caterpillar-Tread Cart for Bad Roads . . . . .	831
Old Dobbin Carries His Umbrella with Him . . . . .	591	A Fire Which Burned for More Than a Year . . . . .	834
Differences in Time Between New York and Foreign Points . . . . .	632	Preventing Dust Explosions and Fires in Grain Separators . . . . .	834
The Mechanics of Shoplifting . . . . .	648	Down with the Mischief-Making Mistletoe . . . . .	840
Making a Huge Map of West Virginia . . . . .	668	A Palace Which Was Eaten by Horses and Cows . . . . .	840
Converting Our Clothes into Rolls of Dust . . . . .	669	A Singeing Comb Which Prevents Burning the Hair . . . . .	84
"Intoxicating" Your Eye-Sight with a Pair of Opera Glasses . . . . .	673	Teaching Music by the Picture Method . . . . .	843
A Tobacco-Can with a Roll of Cigarette Papers Attached to It . . . . .	674	Stilts Instead of Overshoes for Sloppy Weather . . . . .	845
Sitting Down in Comfort on a Painter's Job . . . . .	677	Flags Made of Wire. They Fly Even When There Is No Breeze . . . . .	846
Serving Yourself to a Shave . . . . .	680	A Caterpillar Three Hundred Feet Long . . . . .	846
Two Mines Which Make Marine Warfare More Terrible . . . . .	683	An "Armless" and Inconspicuous Baby Carrier . . . . .	847
Where Did You Get Your Bad Temper? . . . . .	692	A Device Invented by a Blind Doctor to Enable Himself to Write Letters . . . . .	849
A Deadly Man-Steered Torpedo . . . . .	694	Why We Remember Those Big Snow-Storms . . . . .	849
In His Merry "Dogmobile." How a Cripple Gets Along in the World . . . . .	697	A Rescue Saddle for the Fireman . . . . .	854
Here It Is: The New Shaving Harness that Carries Brush, Mug and Mirror . . . . .	699	Will the Great Sphinx Scowl When She Sees This? . . . . .	867
A New Check Protector No Bigger Than a Pocket Match-Safe . . . . .	699	Laying a Brilliant Trail for Bargain Hunters . . . . .	868
Patrolling Eight Miles of Fence . . . . .	704	The "Step Lively, Please!" of Stage-Coach Times . . . . .	868
"Bon Voyage" to the Ohio State Building! . . . . .	705	A One-Man Orchestra . . . . .	870
Man Becomes a Beast in Hand-to-Hand Conflict . . . . .	707	Air-Jet Supports a Football in Mid-Air . . . . .	870
Improving the Imperfect Hen . . . . .	708	How Man's Eyes Differ from Those of the Animals . . . . .	871
A Giant Mail-Box . . . . .	726	How Earthquakes and Similar Disturbances Change the Styles in Architecture . . . . .	871
Clad in a Bullet . . . . .	727	Overcoming the City Boy's Fear of Snakes . . . . .	874
Kneading Clay with the Feet . . . . .	727	Now What Would You Call This New Musical Instrument? . . . . .	874
Watching Dishonest Employees with the Aid of Mirrors . . . . .	739	Ax-Handles Made to Order . . . . .	878
Breaking a Mountain Trail . . . . .	740	Eyes Were Made to See With . . . . .	879
The Lure of the Lorelei Minus the Siren . . . . .	743	Stirrup Stoves for Cold Horse-back Riders . . . . .	883
Flushing Streets with Streams from Movable Pipe- Lines . . . . .	745	A Platform on Wheels for the Lamp Repairer . . . . .	885
The Northern Logger Is the Nerviest of Our Steeplejacks . . . . .	745	Have You Ever Seen a Horse Wearing Trousers? . . . . .	885
How a Tiny Screw Held Up a Great City's Business . . . . .	747	A Time-Saving "Safety-First" Tool for Dynamite Workers . . . . .	886
How West Indians Walk Up Coconut-Palm Trees What Becomes of Old Army Rifles? . . . . .	748	If Robinson Crusoe Had Only Thought of This . . . . .	887
A Pipe Filler Which Takes the Place of the Smoker's Fingers . . . . .	751	Curios Made by Glass Blowers . . . . .	887
Backing an Automobile into a Moving Garage . . . . .	755	Painting Wild Animals' Eyes . . . . .	892
A Four-Family Apartment House . . . . .	785	What? Tail-Lights for Mules! . . . . .	896
		An Unusual Grocery Store . . . . .	907
		Deflecting and Moistening the Air from Furnace Registers . . . . .	913
		A Device for Adjusting the Ends of Steel Rails . . . . .	915
		A Clever Trick Performed with a Lighted Cigarette . . . . .	922
		Substitutes for the Ordinary Carpenter's Levels . . . . .	925
		Making Extended Index Tabs for Books . . . . .	932



# Popular Science Monthly

239 Fourth Ave., New York

Vol. 89  
No. 1

July, 1916

\$1.50  
Annually

---

## The Mine That Hears

By Edward F. Chandler

*It is unnecessary to introduce Mr. Chandler to the readers of the POPULAR SCIENCE MONTHLY. In the present article he describes another one of his remarkable applications of the microphone to naval weapons—an application which is based upon a ripe experience gained in the development of torpedoes and other inventions. The "Mine that Hears" is the result of several years of constant study and experiment by the author, and is described here in detail for the first time.—EDITOR.*

EVERY one knows that in time of war harbors are protected by mines through which an enemy cannot easily pass without the risk of destroying himself. Depending on their nature the mines are called "contact" or "shore-controlled." As the names indicate, the contact mine explodes as soon as a trigger with which it is provided is actuated by a ship, or a bottle of acid is spilled on a suitable chemical; the shore-controlled mine is exploded electrically from a station at the critical moment determined by observation.

Of the two kinds the shore-controlled is the safer. The contact-mine may break loose and become a menace to neutral shipping, as the tragic incidents of the present war have abundantly shown.

The British Grand Fleet undoubtedly owes its safety in part to the submarine mine. It lies in harbors the entrances of which are sown with mines so thickly that a submarine could not worm its way through them without blowing itself up. Whether or not the feat of running through a mine-field has actually been performed in the war there is at least reason to believe that it has been attempted. Mr. Simon Lake, a leading authority on submarine boat construction in this country, not only declares that a submarine can

penetrate a mine-field but has shown how it can be done. He has devised a special type of submarine provided with an antennalike projection or "feeler" in front, which enables a submarine commander to push aside mines with reasonable safety.

If the Lake and similar systems are able to perform their functions it is obvious that no harbor is absolutely safe from submarines. In previous articles published in the POPULAR SCIENCE MONTHLY, I have shown how torpedoes can be automatically steered toward ships, which they are intended to destroy, by employing microphones to pick up the propeller vibrations, and how submarine boats, which are notoriously blind under water, can be directed accurately toward a hostile vessel by the same means. I have worked out a method of applying microphones to mines, which, it seems to me, makes it quite impossible for a submarine to enter a mine-sown harbor, and which also enables the officer in command of a station from which shore-controlled mines are fired to detect the attempt of a surface vessel to enter under the cloak of a dense fog.

The system which I have devised would render it possible to blow up a submarine trying to worm its way into a mine-protected harbor, or a battleship

seeking to enter a harbor at night or in a dense fog. In my system the mines are arranged in groups of four, each group constituting a field unit. On each mine a microphone is mounted.\* These microphones literally hear the hum of a submarine's motor. Not only that but the particular microphone which hears the submarine best, because it is the

The field units are interconnected electrically, so that the entire harbor is sown not only with charges of high explosive but with microphone detectors. Interconnection is necessary because mines 1 and 2 of one group constitute mines 3 and 4 of an adjacent group. Microphones are so remarkably sensitive (they have picked up the hum of sub-



As a submarine progresses through a mine-field in the effort to reach shipping in a harbor, the hum of its electric motor is heard by microphones on the mines. The vibrations picked up by the microphones are electrically transmitted to shore and converted into visual signals by incandescent lamps corresponding in number and position with the microphoned mines

nearest to it, can easily be located. It is simple enough to determine whether a submarine is nearer mine 1 or mine 2 of a given field unit of four mines.

\*For the benefit of those who may be unfamiliar with the microphone I may state that the microphone is an instrument for intensifying feeble sounds or for transmitting sounds and it is based on the principle that the transition between loosely-joined electrical conductors decreases in proportion as they are pressed together. The conductors form part of a circuit through which a current is passing, and the variations in pressure due to sound waves in the vicinity of the conductors produce variations of resistance and fluctuations of the current so that the sounds are reproduced in a telephone receiver. In the modern telephone the transmitter is essentially a microphone, the pressure of the sound waves being communicated to the conductors by means of a diaphragm.

marines fifteen miles away in the present war) that they need not be lavishly employed in every case. Four microphones placed in the four corners of a small field would answer in many cases, all the more so, since a ship can be blown up even though it be fifty feet from the actual explosion. Few of us realize how terrific is the disruptive effect of the gases suddenly generated when several hundred pounds of explosive are detonated.

A mine-field equipped with microphones in the manner indicated is electrically connected with a luminous annunciator. In other words, wires run from each microphone to a board which is divided into squares correspond-

ing in number with those of the mine-field units. Behind each square a lamp is mounted. As a hostile ship passes through a mine-field the nearest microphones pick up the vibrations of her propellers and the corresponding lamps on the board glow. The luminous annunciator may be twenty or more miles distant from the microphones;

it may be in Chicago and the mine-field in New York Harbor, if there were any military advantage in that great separation. It is always possible to follow the course of an intruding vessel merely by watching the lights as they flare up and die out in the squares of the luminous annunciator. The lamps actually visualize the course taken by the vessel under observation. If she enters square 22 of the field the lamp behind square 22 on the annunciator board glows; as she slips into square 23 of the mine-field, lamp 22 is extinguished and lamp 23 flares up. The accompanying diagram will explain the general principle.

Mines are expensive. To provide them with microphones and to wire the microphones to a luminous annunciator board adds to the cost of the installation. Suppose that it were possible to use fewer mines, in other words, to use rather large squares, and suppose that

it were possible to determine not merely the particular square into which a hostile vessel has found its way but the particular mine of that square nearest which it happens to be - would not that solve the problem of cheapening the installation and heightening its effectiveness?

With this idea in mind I have connected with the luminous annunciator board what may be called a "precision indicator," the purpose of which is to show which mine is to be exploded in order to destroy the interloper. A single precision indicator serves for all the mines; for the wiring is such that the precision indicator can be switched into the circuit of any mine-square at will. The details cannot be revealed at the present time, because they are the subject of a patent application awaiting official action.

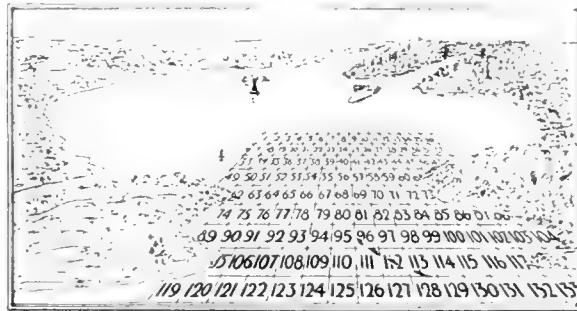

VIEW OF PROTECTED AREA

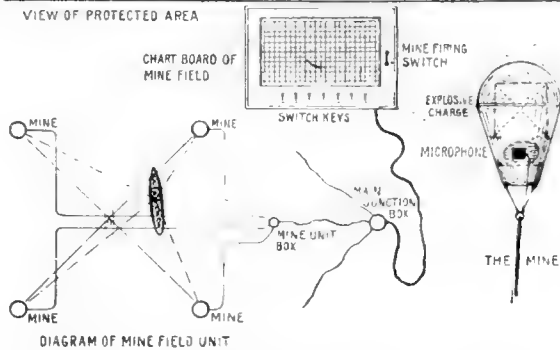

The mines, provided with microphones to hear the vibrations of ships which seek to enter a harbor, are arranged in numbered squares. A luminous indicator on shore, marked off into squares corresponding in number with those of the mines is electrically connected with the microphones. Each mine-square is represented on the indicator by a lamp, which glows in its proper square on the luminous board as soon as a hostile ship enters and is heard. Thus it is possible to follow by the successive flaring up of lamps the course of a submarine or battleship threading its way through the mine-field and to explode the right mine

It may be stated, however, that the devices employed accurately locate a vessel in a square by averaging the momentary responsiveness of the four microphones at the corners of the square. It is very much as if a pencil were attached by four cords to as many pulling devices, the pull on each cord coming from a different point of the compass and representing the intensity of the sound heard in a microphone. Pulled in all

four directions at once, but with different intensities, the pencil will rest at that point where all the forces are equalized. That point, in the case of the precision indicator, is the spot in which the hostile vessel is to be found.

Imagine New York Harbor mined and microphoned in the manner that I have described; imagine the mines connected with a luminous annunciator at Fort Wadsworth and with a precision indicator provided for the purpose of determining which microphone in a square hears the most; imagine a submarine crawling very, very cautiously through the field, thrusting aside with careful antenna, the anchor-chains of the buoyant mines in its path. An American officer glues his eyes on the luminous board. One by one the squares glow before him—19, 36, 53, 66. Unwittingly the submarine's commander plots his course in a trail of light. He cannot be seen with human eyes; and yet he is as visible, electrically at least, as a goldfish in a glass bowl. "Square 78," says the American officer to himself, as a new light flashes up. The time has come for decisive action. He pulls a handle and switches the precision indi-

cator into electrical connection with square 43. The submarine is nearest mine "A" of that unit. for the microphone on mine "A" is intensely active. He presses a button. Miles away a column of water is tossed into the air. An unseen enemy has been destroyed with awful suddenness; twenty brave sailors have been killed with merciful swiftness by a man who never saw their faces.

The naval and military strategist will note at once that the system which I have described has this advantage over the rather haphazard method of utilizing the contact mines at present employed. It renders it possible to destroy a whole fleet, ship by ship, as it progresses into a harbor which is protected. The officer at the luminous indicator board has only to wait until the lamps show that the entire squadron has entered the field to blow up ship after ship at his pleasure. It is also apparent that the system is not limited in its application to the detection of battleships or submarines in a mine-field, but that it can also be adapted to the firing of coast-defense shore-batteries.

### Automobile Scale-Demonstrator

ON the principle that if you can't get the buyer to come to you, you will have to take your product to the buyer, a large manufacturer of scales recently fitted up one of his scales on a light automobile and sent it out through several of the western states as a demonstrator. As shown in the accompanying illustration, the car was fitted with a complete scale and in addition a portable elevator to



An automobile used for demonstrating scales. The owner travels from town to town, the scale enclosed in canvas and the portable elevator carried on the side

raise the grain to the former, so that it really was a working model for the prospective buyer to inspect.

The car travels from town to town, the scale proper being enclosed in canvas enroute and the portable elevator is carried on the side. The power for driving the elevator is secured from the motor of the automobile.

The money-making ability of this outfit has been clearly shown.



### Government Guide - Posts Give Detailed Information

AS a guide to persons not familiar with the reservation, and as a means of conveying to strangers information with regard to its limits, there have been erected on the outskirts of the Ashley National Forest in Utah, at points where main roadways enter it, maps showing the boundaries, roads, trails, streams, lakes, and other points of interest within the forest. The maps are enclosed in glass-covered frames and are attached to sign-boards where copies of notices and regulations concerning the reservation are displayed.

On each map a tack indicates its position with regard to the reservation. The topographical features of the country also are indicated, as well as the

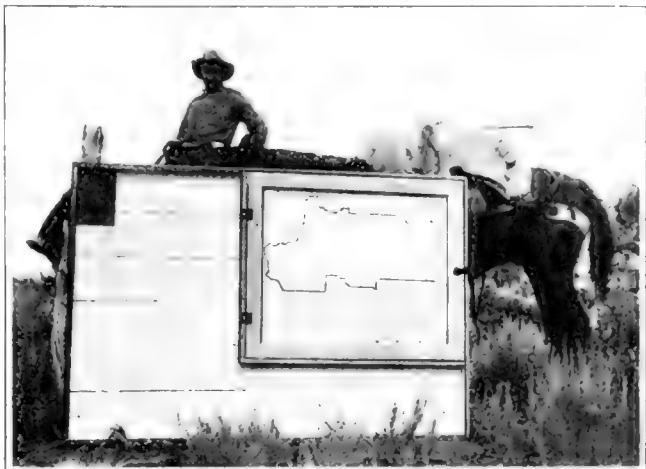

Much useful information about the surrounding country can be gained from these guide-posts

location of the headquarters of the forest supervisor and of his numerous assistants. The maps have proved of great value to stock grazers and others desiring to know the boundaries of the forest.

### End-Door Automobile Express Cars

FREQUENT recourse is made to the express service for shipping automobiles and motor trucks as rapidly as possible in emergency cases. Detroit manufacturers, for instance, usually send their new model cars in this way, employing special trains of eight and nine express cars for the purpose. The very best possible time is not too fast for purchasers of new model cars, who

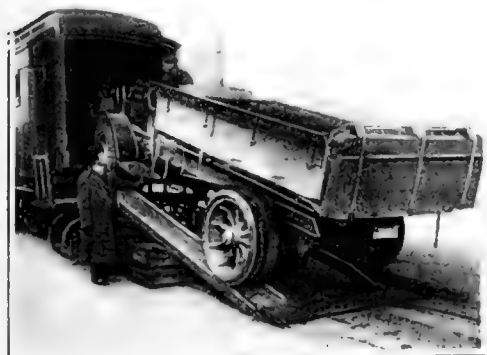

Cars with end-doors for shipping motor-trucks by express

usually wait for their arrival in New York, gasoline can in hand, taking the cars as fast as they can be removed from the express trucks.

One express company has employed specially constructed cars built with two swinging doors that permit loading from the end. Automobiles can be put into the cars under their own power on a rising platform, or they can be pushed in, on the level platform.

One of the largest trucks handled in an express car was a five-ton dumping cart, sent recently by a Los Angeles automobile concern to a mining company at Tucson, Arizona. On account of the high prices paid for all kinds of mineral, the mine operators were working their properties night and day.

Three hours after the order was received, the truck was loaded into an end-door express car by its own power and went out on a train leaving at 3 o'clock. The next morning, it reached Tucson, with an express charge of \$400 attached. It was so badly needed that the first twenty-four hours' use of the truck paid for the transportation expenses.

When the "Guns" of Peace



Wrecking the Italian Towers at the Panama-Pacific Exposition grounds. The base

# Turn Upon an Exposition City



was dynamited and the big pillar crashed to earth, a mass of splintered wood

# The Transit of Exposition Glories



Festival Hall was considered to be an acoustic masterpiece. When the great organ was removed to San Francisco's new art center the same dummy-engine that helped build the structure helped to destroy it. The Tower of Jewels adjoining it suffered a less severe but more inglorious death at the hands of the destroyers. After the scintillating jewels had been plucked from their setting and sold to admirers, a stick of dynamite was touched off and the tower went the way of its numerous predecessors

The Court of the Universe was perhaps the most auspicious exhibition of temporary art at the exposition. World-famed artists worked months planning it. Day laborers destroyed it in a few hours. The various historical groups forming the crowning features of the lofty court arches were not spared when the exposition had lived its day. The most delicately fashioned figures among the groups were pulled to earth and were followed, in turn, by the beautiful arches themselves

# Reducing an Exposition to Dust

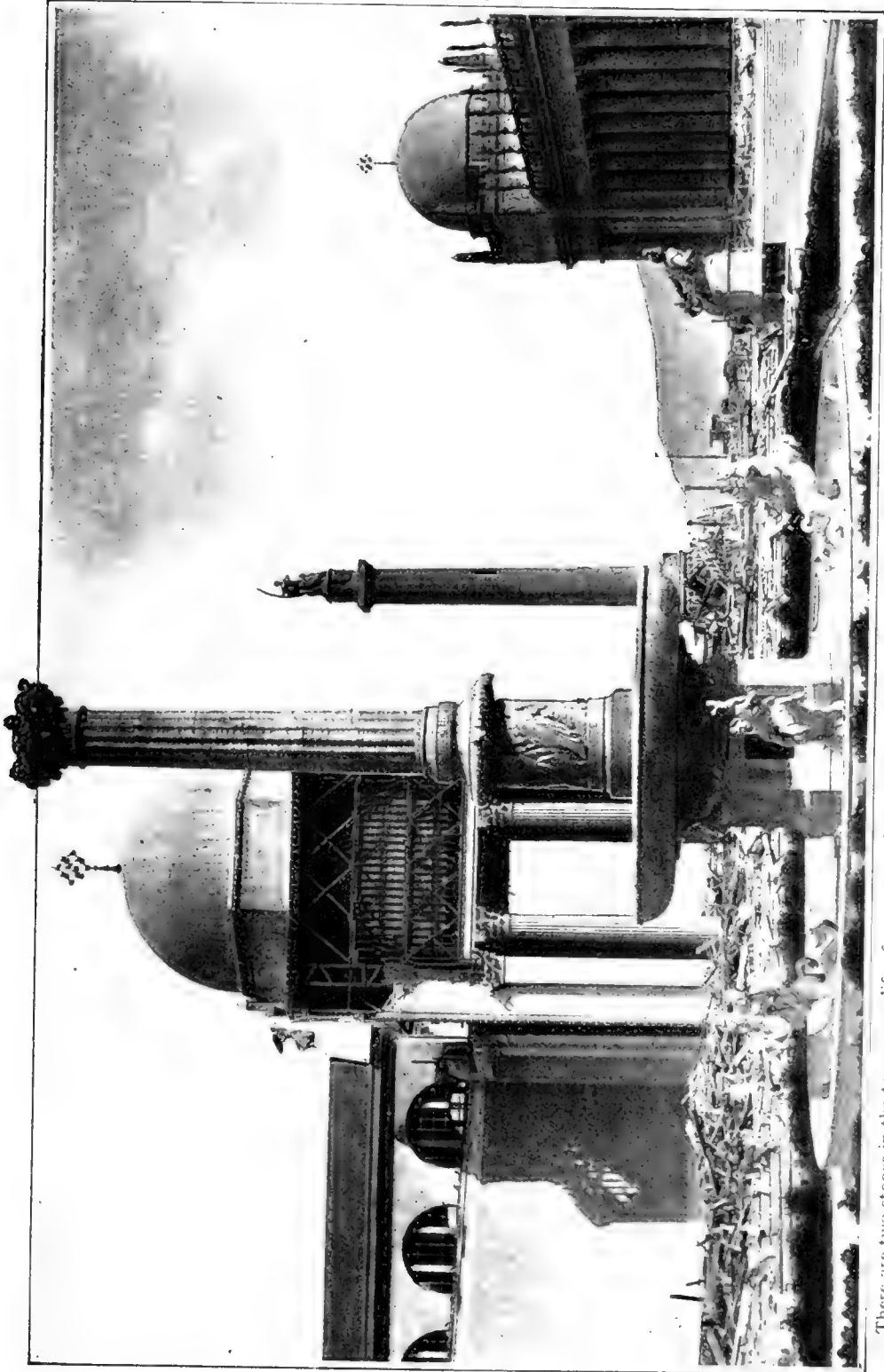

There are two stages in the temporary life of every exposition—the constructive and the destructive. In one, man builds with infinite care, in the other he destroys with reckless abandon. Here the Palace of Machinery is being reduced to dust

# Doing Without the Caddy

The automatic caddy is a holder on wheels, which can be easily taken over the course by the player himself. If the ground is rough the caddy may turn over but it can easily be righted

The automatic caddy can stand upright, by swinging the wheels out of the way in the manner here shown

The holder is propped in a convenient inclined position for removal



Golfers no longer need the services of a boy to carry their sticks. An automatic caddy on wheels does all his work

**A** NEW mechanical caddy for the golfer has been invented by John Deere Cady of Moline, Illinois. It is an ingenious, wheeled holder for golf-sticks, which the player can easily take over the golf course without the assistance of a caddy. Indeed, the caddy can be entirely forgotten, unless the player loses one of his golf balls, when he can call the caddy to his assistance and make him an offer to find the lost ball. As is usually the case, according to golfers, the caddy will readily agree to the bargain and then saunter off, find the ball, and forget to return with it.

However, the device illustrated here-with should make the player somewhat independent at least. It is made to hold the golf-clubs in a convenient inclined position for removal. The most efficient caddy could not improve on this particular feature. In wheeling the holder along, the player merely has to grasp a handle pivoted at the top and walk jauntily on. If the ground is a bit rough the automatic caddy may turn over a couple of times but it can be easily righted.

When the player has finished his game the automatic caddy can stand upright and thus take up a minimum of space



Golfing at Home

THE apparently leisurely game of golf doesn't consist merely in "knocking a pill around a ten-acre lot," as ex-President Roosevelt is credited with having described it. Furthermore, the game doesn't need to match well with special clothing, shoes, clubs, cocktails, professional instructors and similar adornments. It is now possible to bring it into the home and have the family play it without being decked out in sport shirts.

Indeed, the indoor game is the next best thing to the outdoor game itself. It is said to parallel accurately all the characteristics of an outdoor course, and afford true putting practice. It can be played on any rug or carpet of good size.

The player starts off with a mashie shot from a felt tee over a bunker. After holing out, the next stroke is through a low and narrow hazard calling for perfect direction to the first disk.

The disk is so constructed that a ball will enter from any angle with only a slight amount of resistance;

but once in, it cannot roll out again. The three disks, hazard and hole are easily turned around, so as to face the ball. Should a ball be played against the outside walls of the hazard, it will be deflected sharply to one side but will not roll beyond the edge of the rug.



Indoor golf, essentially the same as the outdoor sport

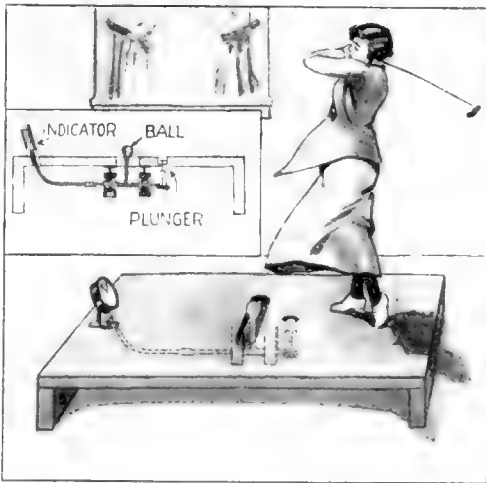

Every drive is registered in yards by this machine for teaching beginners in golf

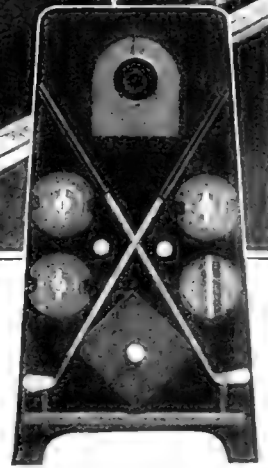

Devices for teaching special golf-strokes at home have been invented almost without number. One of the latest is a machine which has been invented to teach scientific driving.

The diagram explains the working of the golfer's "first aid." It is a ball mounted on a ball-bearing shaft. It has

all the fascination of a roulette wheel and your drive is registered on the calibrated dial.

A plunger-spring set in the floor brings the ball to rest "all tee'd" and enables the player to drive off as frequently as he wishes.

# A Duck-Boat as an Automobile Top

NOVEL camping outfits have, from time to time, been introduced, but it is doubtful if anything more daring and ingenious has been conceived than an automobile with a duck-boat for a top, the invention of G. W. Clark of Glendale, California. The boat not only takes the place of the regular top, but also serves as a sunshade. In a very few moments the car is made weather-proof simply by attaching water-proof sides to screws located around the outside of the cockpit. To reduce weight, the seat has been taken from the boat. At the proper time one of the spring-seats is taken from the car; it fits snugly within the boat. In transit the bars are tightly strapped within the boat, out of the way.

The boat is held in position above the car by four strong steel braces. The two forward braces, fastened to the sides of the car immediately in front of the windshield, extend upward for a distance of four feet, and between their upper ends a rubber-covered steel cross-piece is fastened, curved downward slightly to accommodate the oval top of the inverted boat. To hold the boat firmly down against this cross-piece, a heavy strap is run through openings at the tops of the uprights and over the boat, and drawn tightly against the upturned bottom. The rear braces, which are located just behind the seats, have been arranged in the same manner. Additional braces keep the boat from moving forward and backward.

To convert this boat into a bed it is taken down and placed right side up on the ground. The two spring-cushions from the car are placed within the cockpit, their tops being about flush with the top of the cockpit-rail. Upon this foundation a bed is spread.

When the ducks alight out of the

range of the "high boot" hunter, the owner of this car takes down his boat and goes after them. Often he takes his duck automobile to mountain lakes where ducks abound, unfamiliar with boats.

This duck-car carries everything necessary for a successful and enjoyable outing trip. Behind the seat is a large platform upon which is a spacious trunk.

This is divided into sections for various kinds of food, hunting material, and the like. It can easily hold enough provisions for a month's trip of a party of two people. Upon the trunk is an "A" tent, within which the bedding is rolled, and behind the trunk is an extra tire. Water-bags

and gun-holsters, are either strapped to the running-boards or hung to the sides of the car.

The boat may be set up at home as a "blind" for shooting geese, and when the hunting party reaches the particular point where they wish to wait for the geese no time need be lost in lowering the boat to the ground and placing it into position at once. Geese and ducks do not resent the appearance of an automobile provided it goes along slowly but surely. If it stops they get uneasy, of course.

With the boat rigged out as a blind at home, by using corn-stalks and weeds and sewing them to wire-strands and then attaching the whole to the boat-frame, the party of hunters can leave for the hunting field and when they spot a flock of geese flying within range they can lower the boat as the automobile chugs along slowly and drop it to the ground, falling in behind it. The chauffeur can continue driving the car and the hunters can then fire from behind the impromptu boat-blind without being discovered by the birds.

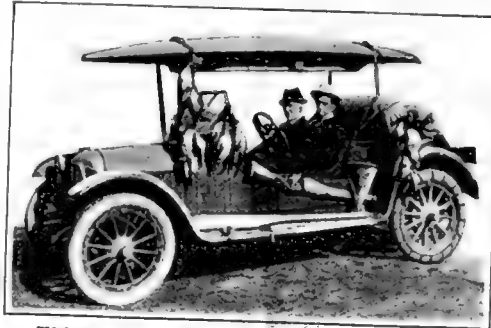

This boat can be carried to any duck pond which is accessible to an automobile; on the road it serves as a canopy



Four strong steel braces, connected by rubber covered steel cross-pieces, act as supports for the duck boat when it is used as an automobile top. The spring-seats of the automobile can be transferred to the boat for use in the water and as a bed

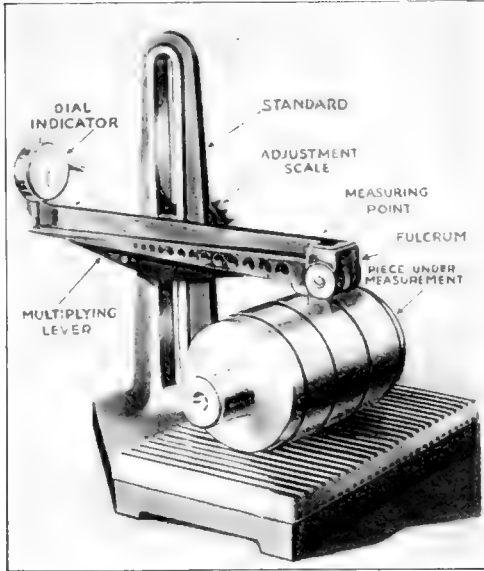

If a machine part is too small by one twentieth the width of a hair, this measuring scale can detect it

### A Measuring Machine More Sensitive Than a Human Being

THE average person has little conception of the accuracy with which it is necessary to work on some classes of machinery. Ball-bearing parts, for instance, are produced in large quantities, yet in some cases the limit of error is placed at one tenth of one thousandth of an inch or about one twentieth the thickness of a human hair. Special measuring appliances are needed to make these fine measurements in a commercial way because hundreds of duplicate parts must be gaged per day. The human sense of touch is coarse in comparison.

The multiplying indicator illustrated is a very satisfactory device for measuring parts that must be accurately gaged without loss of time. The machine consists of a substantial base-plate with an accurately ground, hardened steel face and an integral standard carrying a measuring appliance. The dial-indicator reads in thousandths of an inch, each graduation representing a one-thousandth inch movement of the indicator stem.

The work to be measured is placed under the measuring point on the

multiplying lever. As this is very near the fulcrum, a relatively slight motion will be changed to one of ten times that magnitude at the dial-indicator. If the work is but one thousandth inch larger or smaller than the standard, the pointer of the indicator will move over ten graduations on the dial. An error of one tenth of a thousandth will move the pointer one graduation. The measuring arm may be moved up or down to accommodate work of varying diameter, and when gaging duplicate parts, it is set by a standard master-disk of the correct dimensions. Any deviation can be easily detected by a comparatively inexperienced operator.

### Lighting the Inside of an Oven

BAKER'S oven, illuminated on the inside, is a great advantage since otherwise the contents cannot be closely inspected, unless withdrawn from the oven. An arrangement, suitable for electric or gas lighting, is shown in the illustration. The door is hinged to the frame by means of pins. One pin is provided with a counterweight to facilitate the action of the door in opening and closing. The other pin has a crank-arm. On an extension on the door is mounted a knife-switch, with two short fingers to engage with the crank-arm. The opening of the door establishes an electrical connection with a lamp mounted in a casing near the door. If gas is used, the crank-arm engages with the shank of a valve which regulates the flow of gas to the burner in the casing.

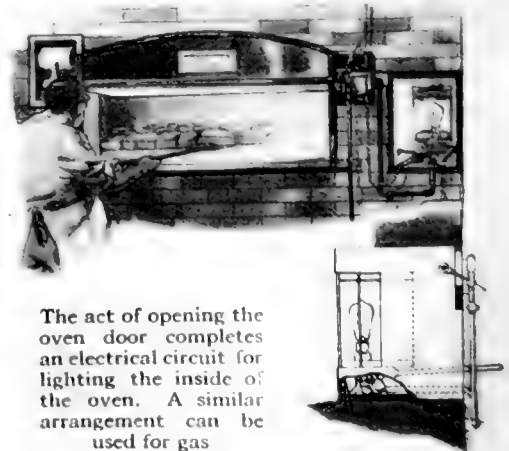

The act of opening the oven door completes an electrical circuit for lighting the inside of the oven. A similar arrangement can be used for gas

**A Mechanical Whip**

**A**N apparatus easily attachable to the tongue or thill of any horse-drawn vehicle enables the driver to wield a whip without touching it. He does not have to carry his whip, yet it is ready for use at all times. His hands are free when operating harvesters, dump-wagons, riding-plows, and this is a decided advantage.

The construction of this device is based on the spring and lever principle. An upright iron support is attached to the tongue or thill. The upper part is bent back toward the driver with the end expanded into a ring whose diameter is horizontal. Fitting in the ring is a ball

through which passes a whip-support. This extends upward for the reception of the whip, and downward to connect with a stout spring.

A long rod is attached to the whip-support at its junction with the spring, and this extends backward to the driver's seat, terminating in a hand-grasp. This rod is suspended in its middle portion from an angular bracket attached to the body of the vehicle. This supports the rod and prevents the ball from dropping. The action of the ball and spring is such that the whip may be manipulated in any direction and when released



By means of a lever, this whip can be applied in any direction

returns to its original position. It is a more humane weapon than most whips.

**Welding Soft Metal to Hard**

**F**OR welding copper or aluminum to iron or steel or for welding to any hard metal, such as iron, nickel, steel or the like, a comparatively soft metal such as copper, zinc, silver or gold, an apparatus has been devised which brings the surfaces of the two dissimilar metals into contact with each other in a vacuum or partial vacuum, and then heats the metals to a high temperature.

By producing a vacuum around two metals they can be quickly welded. The air in the metal furnace is exhausted and an arc formed between the two electrodes. The heat melts the metals and they intermingle readily. This welding can be effected between any soft metal and one which is hard

The apparatus comprises a container or furnace preferably made of refractory material with a metal jacket provided with a doorway which, when closed, makes the interior air-tight. A pipe or conduit enables the air to be exhausted by suction. After cleaning, the two dissimilar metals are placed in contact with each other within the crucible.

The doorway is sealed, the air exhausted, the current turned on, and an arc is formed between the electrodes, which forms sufficient heat to bring the temperature of the two metals near the fusing point of the softer metal. When this occurs a weld or union of the surfaces is the result.

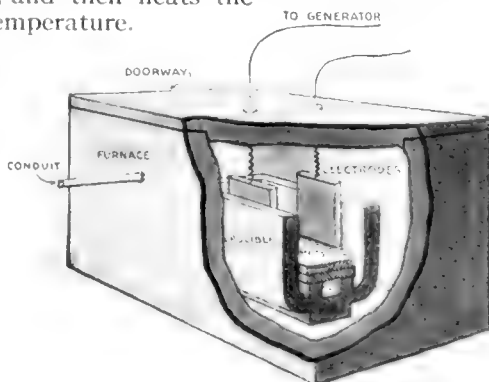

# Protecting a Battleship with a Belt of Air

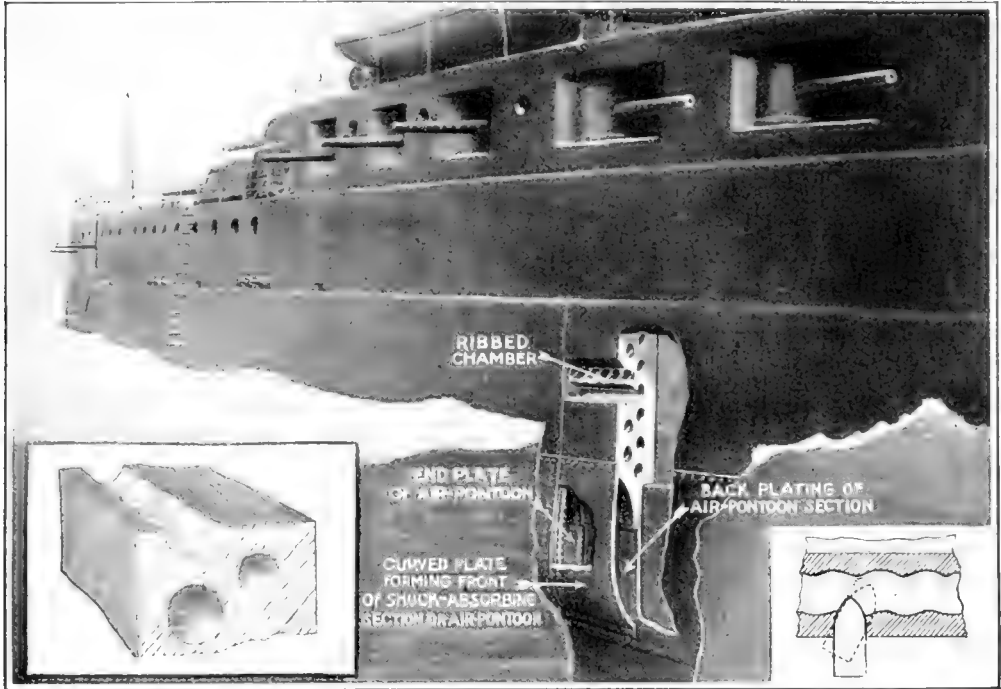

A new battleship armor is built on the principle of the shock-absorber. The corrugated chambers, backed by others of smooth-bore, first deflect the shell, and, when it explodes, the air takes up the shock and the expanding gases are carried off by the chambers, which are destroyed but save the hull itself from destruction

**R**EAD the accounts of the battles fought off Heligoland and the Falkland Islands, in which ships protected by heavy side armor were sunk by gun fire at ranges of five miles and the question must occur: What is the good of armor? If twelve and more inches of steel can be penetrated by the fifteen-inch guns of a British battle-cruiser at distances of miles it would seem as if victory in sea engagements is a matter of hitting power rather than of protection. That armor of some kind is necessary would follow from the fact that naval architects are very close students of naval history and that they promptly apply in the construction of fighting ships the lessons taught on the proving-grounds and in battle. That the heavy gun seems for the time being to have gained the ascendancy over armor is

proved by the fact that in battle-cruisers high speed and enormous striking power are considered more important than steel sides; for the armor belt of a battle-cruiser is only twelve inches—hardly sufficient protection against anything but projectiles of low caliber and low striking energy.

Inspired by these considerations, Louis Gathmann, whose experiments in hurling high explosives against armor on proving-grounds attracted much attention some sixteen years ago, has invented an entirely new system of armor protection which deserves consideration. His object is to obtain not only protection, but lightness; for the heavier the armor of a ship the fewer must her guns be or the weaker her engines on a given displacement.

In carrying out his ideas Mr. Gath-

mann would provide a ship with a chambered shell-resisting section and with a shock-absorbing section, the first above the second, as the accompanying illustration shows. The chambers of the first or shell-resisting section are really horizontal tubes, the front series of which are spirally ribbed. "Should a projectile penetrate the hard face of the armor," says Mr. Gathmann, "it would force its way through the line of least resistance, and thereby glance upward, downward or sideward as the case may be, turning or tilting the projectile, thereby destroying its penetrating power; such shells may fracture or explode, but without penetrating the armor."

A fifteen-inch shell carrying high explosive generates gases on exploding which exert tremendous pressure.

That pressure must be absorbed, or else it may breach the ship below the armor belt. So, Mr. Gathmann attaches to the lower edge of his chambered belt a series of air chambers or pontoons, each independent of the other.

Study the illustration which accompanies this article and you will see that this shock-absorbing section consists of five walls: a downwardly-extending portion of the armor belt; a rear plate to which that downwardly-extending portion is bolted; a curved front plate, and two end plates to enclose the pontoon or chamber.

The pontoons seem flimsy, and in reality they are. But they are intended to be destroyed. The pressure of the gases from a huge shell will disrupt one, two, perhaps three shock-absorbing or pontoon sections, but the rest will remain intact. The air within the chamber will have a cushioning effect. Water will rush into the compartment, but the pontoons will still remain in place.

### An Instrument for Plucking Flowers

A NEW German invention seeks to simplify the tedious and fatiguing labor of picking flowers and seeds. The instrument, already patented, which is here illustrated, consists of a sheet-metal tube combined with one-blade shears. The lower front part of the tube is formed as a seven-pronged fork

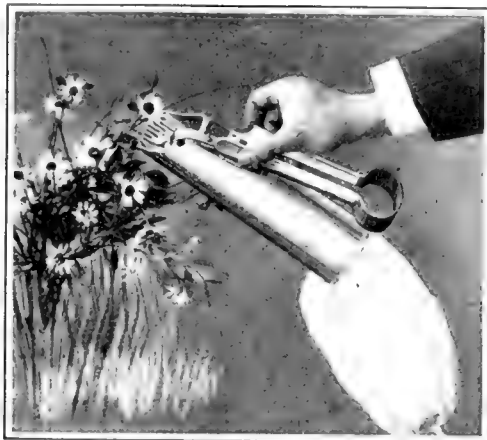

Rapid gathering of flowers without injuring the stems can be accomplished with this instrument

and this fork is advanced towards the flower to be gathered from below it. The flower is caught by the prongs and is cut from the stem by a knife above the fork that works upon a light pressure on the handle of the shears. When separated from the stem the flower falls through the tube into the bag underneath.

The rapidity and ease of gathering reduces the ex-

pense. It is also claimed for this instrument that the plants are not damaged as in hand-picking, in which twigs and branches are easily injured and the entire plant is frequently torn out of the ground. Good service has also been done by the device in gathering seeds. The difficulty here in hand-picking is that the dry pods are often crushed and the seed scattered, while by the new method the seedpods fall uninjured into the bag and no seeds are lost. It is also hoped that the instrument, which is the invention of an apothecary of Colditz named Meyer, may prove serviceable in hop-picking.

The flower-cutting instrument has been found particularly effective in cropping dandelions when the plants are young and the flowers only a few inches high. For this kind of work the device is operated along the ground like grass-cutting shears, and as fast as the metal receptacle fills it is tipped and the severed flowers fall into the bag.

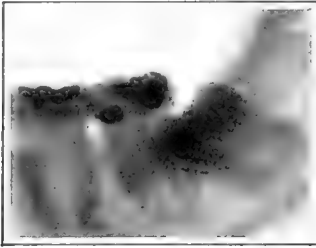

A badly impacted wisdom-tooth. Radiograph shows the need of cutting away portion of jaw

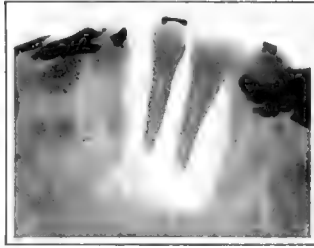

Light area shows extent of jaw-bone affected by pyorrhea, commonly called Rigg's disease

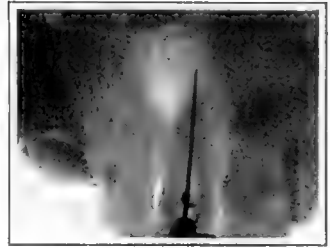

The instrument has passed through the tooth into an abscess which was located by the radiograph

## What X-Rays Can Do for Your Teeth

THE purchasing agent of a large corporation took a night train from Buffalo for Pittsburgh. It was cold and the next morning his face was fairly alive with pain. He concluded that neuralgia had singled him out as a victim. Consultation with a physician resulted in about the same opinion. And every time he got cold his face twitched with pain. In the course of time this man visited his dentist. The dentist had just installed an X-Ray outfit. Merely as an experiment a radiograph was made of the man's jaw. The tiny film when developed showed that a tooth was improperly filled. A small portion of the root canal at the extreme end of the tooth had not been cleaned out. Whenever the purchasing agent's temperature rose from a cold or other ailment, his blood pressure, of course, rose also. And when the blood pressure rose, the tiny blood vessels which nourished the tooth swelled and the swelling pressed against the sensitive tooth. The result was a pain of a twitching sort which almost

anybody at first might call neuralgia.

There is absolutely no pain connected with the taking of a radiograph in dentistry. The operator simply places a small piece of film in the patient's mouth which the latter holds in position with his thumb. The patient then closes his eyes and holds his breath for a few seconds and it is all over so far as he is concerned. The dentist can develop his film in a very few minutes. He is able to draw his conclusions while the film is still wet because the signs which mean so much to him are as plain on a negative as they would be on a finished print.

The X-Ray outfit can be used to detect any number of defects in a filling. It can also be used as a check on another dentist's work. Furthermore, it enables the dentist himself to give the patient information of an absolutely accurate character on the condition of the teeth. For instance, a radiograph would show the dentist and the patient whether it was necessary or not to pull the tooth instead of treating it, with the ultimate intention of prolonging its existence.

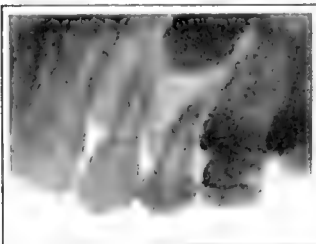

Radiograph which was taken to locate an eye-tooth which had not grown out due to crowding



Showing condition of jaw-bone after the extraction of an abscessed root. Dark areas are gold fillings

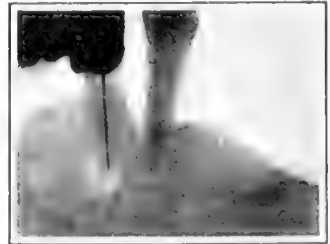

Here the X-Rays show an abscessed area indicated by the light spot at the end of the tooth



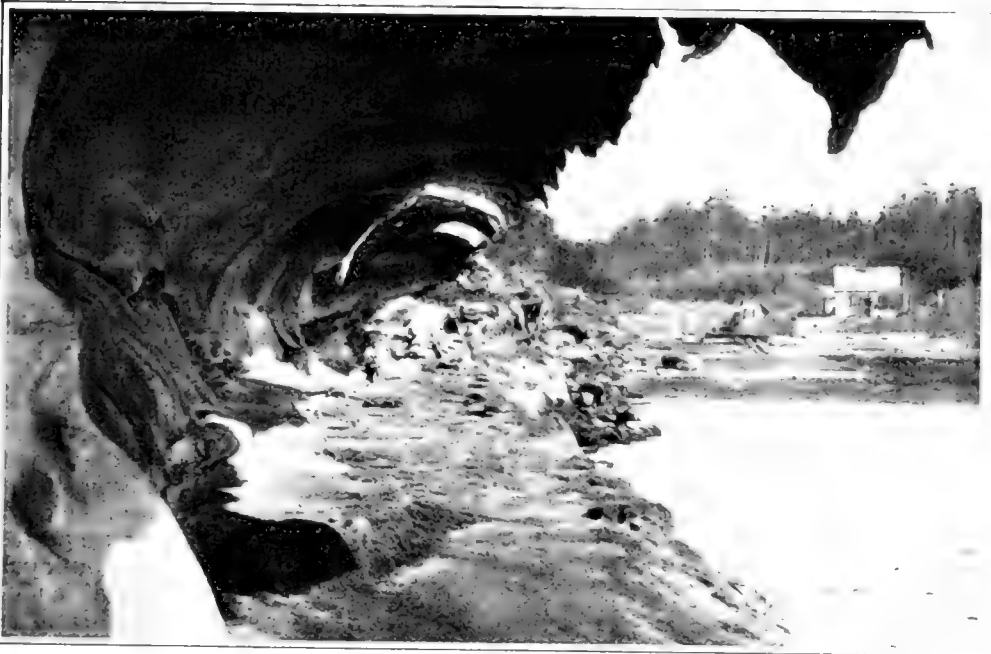

A natural shelter worn away by the persistent grinding action of pebbles and sand thrown against the rocks by the splashing of waves

#### How Sea Caves Are Made

CONSTANT warfare is being waged between water and soil. The photograph shows a rocky recess in a friable sandstone which has been excavated by the scour of currents and beating of waves along an arm of the sea on the east side of Vancouver Island. The bed which the waves have cut away is obviously of softer stone than the underlying one, while the overlying layer is hard and resistant and sufficiently massive to overhang for some distance. The view is an excellent illustration of shore erosion. It is not exactly correct, however, to speak of waves or running water as scouring and grinding agents. Water alone has little power to erode stone but it is a potent grinder.

#### A Lamb with Two Coats of Wool

THE little lamb in the picture has two coats of wool, but only one of them is his own. A ewe is disinclined to adopt some one else's children, even if her own do die. To deceive her into the belief that her own lamb is still living, its pelt has been used as a coat for another lamb. She recognizes the pelt by the smell, and believes it to be her lamb.

If the adopted lamb is a twin or if its mother is dead, this arrangement is greatly to its advantage, but once the mother discovers that she has been made the victim or the "goat" she leaves the adopted young to its own destiny and refuses thereafter to have anything to do with it even though its pelt be changed again.



It is a wise ewe that knows her own lamb

# Yachting in the Air

## Why Ballooning Will Never Die

By Carl Dienstbach

**T**HIS seems to be the proper moment to realize how completely the term "aeronaut" has changed its century-old meaning. Until recently only the balloonist might still claim to be a true aeronaut, fearless of the elements, starting anywhere, rising to extreme altitudes and traveling long and far, while the average aviator was confined to his "flying grounds." But today

standing this transformation, however, the old-fashioned gas-bag maintains its popularity. In a past age people referred to it as a thing which "didn't know where it was going, but was on its way." Today, when highways are swarming with cheapened motor-cycles and automobiles, the privilege of choosing one's destination has largely lost the fascination it



Gas bags when fully inflated

used to have. Yet it remains for the simple, old-time, wind-driven balloon to give us the lure of sailing into limitless space and of enjoy-

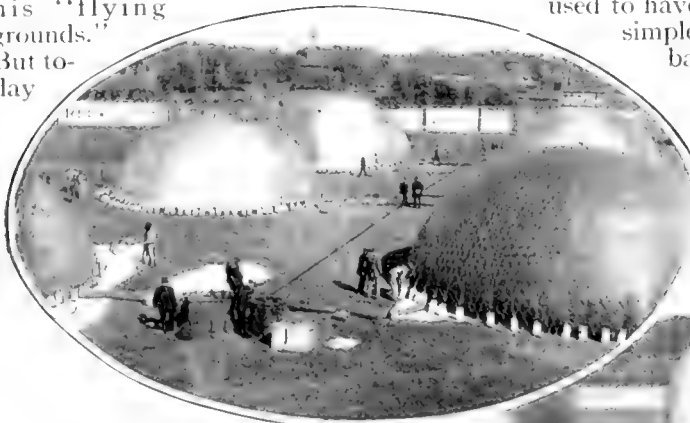

Above, the first stage of inflation when the sand bags have to be closely watched to prevent tearing of the envelope. At right, the bags resemble huge puff-balls. At this stage all that is necessary to tip them over is a strong wind

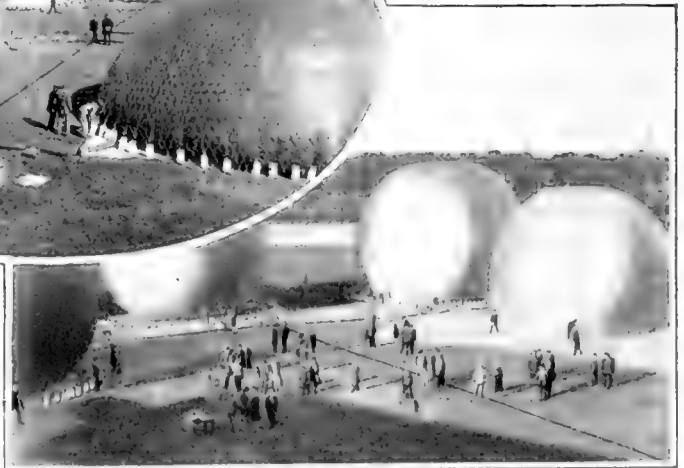

there is not one among the army of war aviators whose exploits are not as daring as those of any balloonist. Notwith-

ing a view of ever-changing scenery far grander than that afforded by the highest mountain peak. Indeed, the

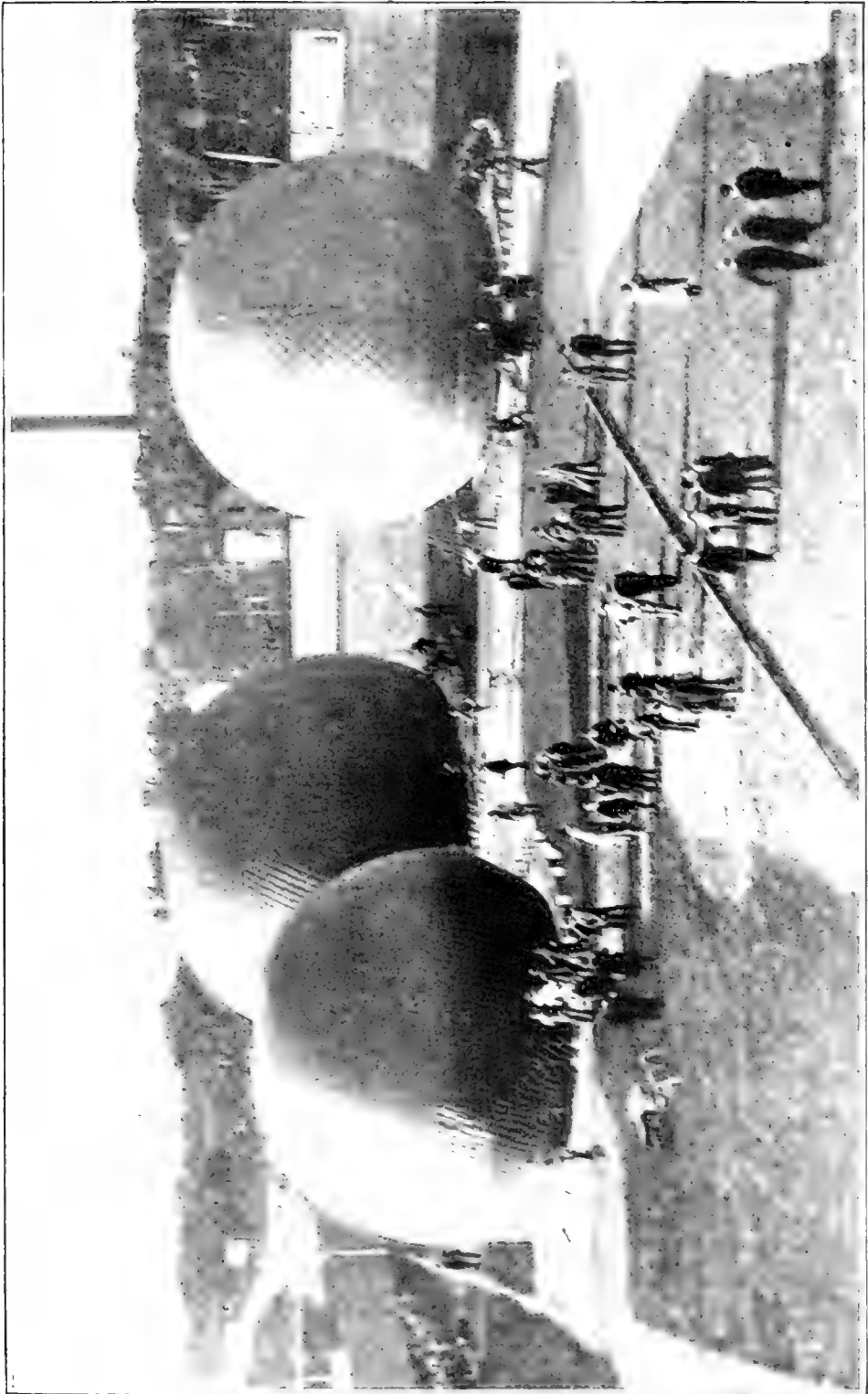

The preliminaries of a balloon ascension. Ready to pull the bags "off their feet." The next step is to attach the basket

extreme simplicity and cheapness of the balloon will keep it popular for many days to come.

*How Balloons Are Made*

It is a comparatively simple matter to make a balloon. All one needs is a large quantity of thin cottoncloth, some linseed oil, a light, wide-mesh "fish-netting," a small amount of medium-gage rope and a big willow basket. The valve on top of the gas-

bag is essentially only a small, close-fitting circular wooden door which any experienced cabinet-maker could construct. Other accessories are of equal simplicity.

If it were not for its prohibitive size and the cost of the material a balloon could easily be made by a handy amateur. Where there is natural gas light enough for inflating, as in Kansas, a balloon ascension can be carried out in a short time. The

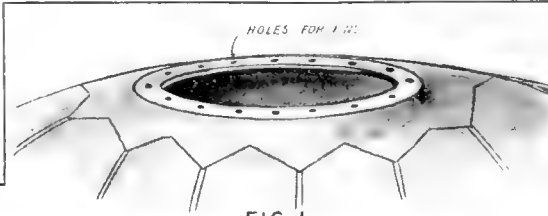

FIG 1

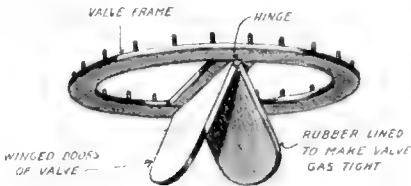

FIG 2

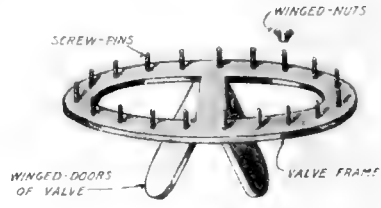

FIG 3

The "wings" are rubber-lined and gas-tight

The circular ring with holes arranged for pins

Two hanging "wings" form the circular wooden door

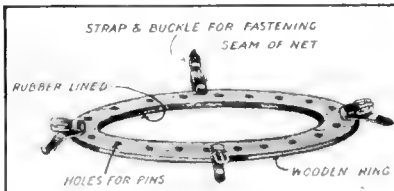

FIG 4

The seam is buckled to the margin by a series of short straps which hold it securely in position

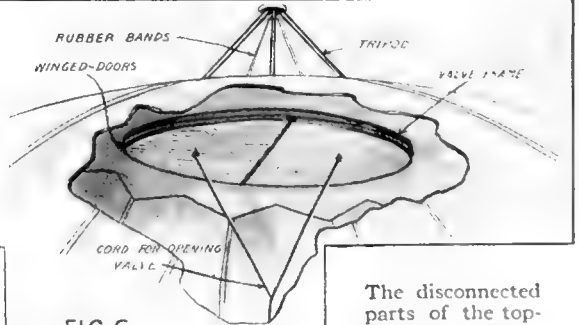

FIG 6

The disconnected parts of the top-valve, showing arrangement

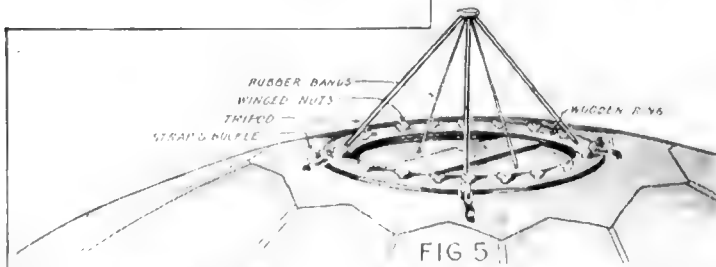

FIG 5

The top-valve equipment closed in its correct position

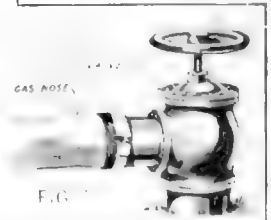

FIG 7

How the hose is fastened to the gas-main

requirements are a moderately large, level space, a gas-main several inches in diameter, a cartload of sand, two dozen sandbags (eight by sixteen inches, with four one-foot cords collected in a hook around their open end), and plenty of strong men who aren't afraid to hold on to the bag.

The outer part of the empty rolled gas-bag is the short hose, called appendix, at the balloon's lower end. A short cylinder of equal diameter is slipped into its end, and a longer hose of balloon cloth is stripped over both and securely tied around them. The other end of the hose is similarly tied to the outlet of the gas-main, whereupon the bag is unrolled and spread around the appendix as the center. The seam of the round opening on top of the bag is tightly screwed into the circumference of the valve. The seam of the similar opening in the net is buckled to the same margin by a circle of short straps. The net is spread in the same manner, and a wide circle of sandbags, previously filled, is built around the spread bag and net and hooked into the meshes.



tain out of a circle of cloth. Even after the buoyancy increases the sandbags lash it firmly, for their total weight is far greater than the maximum lift, and their individual weight overcomes the fraction of lift exerted by the mesh to which each is hooked. As the bags narrow in on the net they crowd together. Finally they reach the lowest meshes and are lifted from the ground by the attendants. Then the fully inflated balloon, now permitted to rise sufficiently to untie the hose from the appendix, is led to the basket nearby.

The ends of the ropes into which the net issues are hooked by loops to the "collecting ring" above the basket, and the hooks are now released from the meshes and put over the ropes. By sliding them slowly in toward the basket the balloon is allowed to rise to its normal position above the basket by finally hooking clusters of bags around the lower ends of the stout basket-ropes. After a few details have been attended to, such as tying the appendix with a knot, which can be jerked open while ascending, and arranging valve, rip-cords, ballast-bags and instruments, the passengers climb in.

*How the Balloon is Inflated*

Once the gas is turned on it dilates the hose with a roaring sound, rushing into the balloon and raising the center of the spread. You have the impression that the gas which finds it so hard to puff out the cloth could never lift a man, but you do not realize the physical fact that the buoyancy is increasing continually with the additional space occupied by gas. Soon the meshes of the net begin to pull the bag hooks, and since the circle occupied by the spread cloth narrows with the increasing inflation the bags must be moved in gradually and evenly.

It is an interesting sight to see the balloon grow like a moun-

*The Start of an Ascension*

The wind soon pulls the basket "off its feet" and there is considerable bumping and scraping, during which it is a convenient thing for those inside to have an "upper berth." Following this comes the ticklish process of tentatively taking off sandbags until the lift is supposedly equal to the load and of letting the raised basket go for a moment to see whether it will fall or rise. When the final "let go" is given the excitement begins.

During the first moments of rising there is that queer sensation of riding in an endless elevator or Ferris-wheel. Soon this is forgotten in a world of silence.

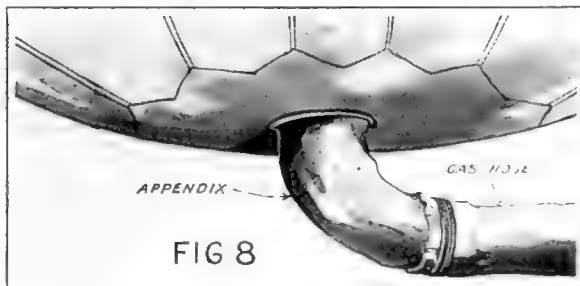

An air-tight attachment must be made between the gas hose and the appendix

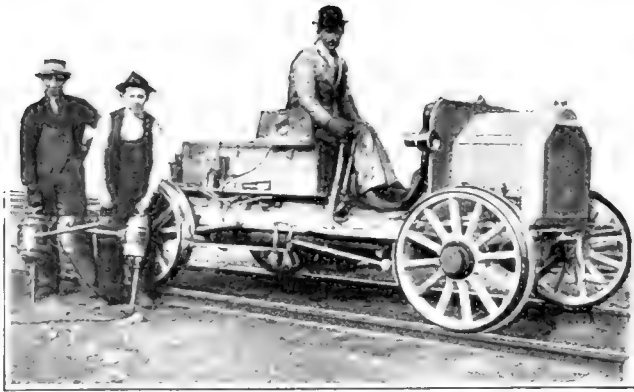

Driving spikes in railroad ties is accomplished with socket-wrenches run by motor

### Driving Railway Spikes with a Motor-Car

THE latest thing in spike-driving apparatus for railroad use consists of an ordinary motor-truck mounted on railway car wheels. Attached to the

with the screwing-machines, may work on two thousand feet of track without moving the car from its original position. Should a train come along, the car can be shifted to one side by means of a portable turntable quickly operated.

### Portable Electric Tire-Inflator

AUTOMOBILE tire manufacturers always impress on their customers the necessity of inflating tires to the proper pressure. If this precaution is neglected, the tire walls deflect more than they should, and the plies of which the tire carcass is composed tend to separate. This produces a weakening of the shoe and greatly diminishes the life of the tire; a blow-out is inevitable under these conditions.

There is no excuse for this neglect if the motorist is provided with the compact air-compressor outfit shown in accompanying photograph. In the device an electric motor and pump are combined in such small compass as to be readily handled. The device weighs but thirteen pounds and can be plugged into any light-socket where the potential is one hundred and ten volts, the almost universal lighting current. The current may be either alternating or direct.

This small outfit furnishes only cool, clean air. It will pump up to one hundred pounds per square inch pressure, which is sufficient for ordinary use.

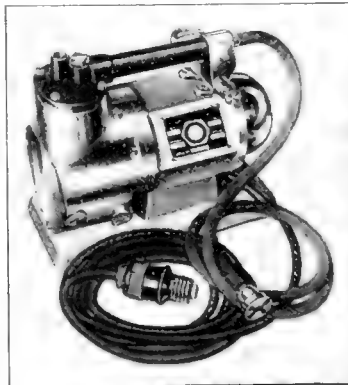

Sufficient hose is provided to make quick connections with any light-socket at hand



Attach the air-compressor, which weighs only thirteen pounds, to an ordinary light-socket and inflate your tires in a few minutes

**Keeping Things Cold in the Automobile Refrigerator**

**U**SED by the owners of a large farm in Newport, Minn., to deliver milk, butter and kindred dairy products within a radius of twenty-five miles, the one thousand-five-hundred-pound truck shown in the accompanying picture is in reality a refrigerator on wheels. It is equipped with a double-sheathed body, filled with sawdust between the inner and outer skins to prevent radiation.

The interior is kept cool by means of a conventional ice-box placed directly under the roof at the front end, which is large enough to hold three hundred pounds of ice. The box is zinc-lined and is surrounded on all sides by a layer of charcoal. It is drained by means of a pipe extending down through the double floor to within a foot of the ground. Directly beneath the ice-box are three

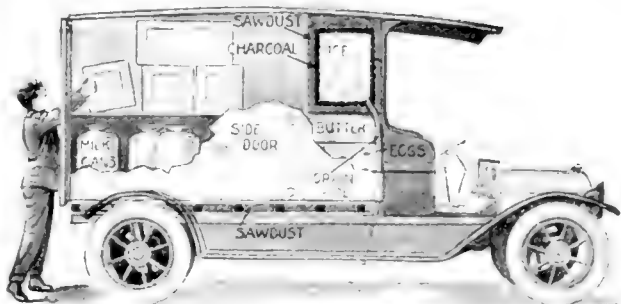

At last we have a refrigerator on wheels, for delivering dairy products

shelves crosswise of the body for carrying butter, bottled milk, pot-cheese, etc. Ten-gallon cans of milk are carried at the rear.

The large cans of milk or the goods carried on the shelves can be removed easily and quickly without opening the rear doors, this being accomplished through the two side doors, one on either side, shown directly behind the shelves. The doors are zinc-lined and when shut are air-tight.—J. HUSSON.

**A Record Motor-Truck Load of Barrels**

**C**ARRYING a part of its big load above and in front of the driver's cab, the motor-truck pictured is equipped with a special rack-body capable of holding three hundred and eighty-five barrels. This is one hundred and thirty-five more than can be loaded into an ordinary railroad freight car. Some idea of the big load may be gathered from the fact that the extreme fore and aft length is about twenty-eight feet

and the height above the ground, fifteen feet.

The vehicle, a three and one-half ton truck, is owned and operated by a manufacturer of barrels in Rock, near Middleboro, Mass. Most of the company's product is used by the cranberry growers in Plymouth county and down Cape Cod way. The growers now get their barrels directly from Middleboro by the motor-truck and in much less

time than when shipped by freight, due to the elimination of railroad delays and the added haul from the plant to the railway at one end and from the latter to the cranberry fields at the other. In addition, loading at the sending end and unloading at the receiving station are avoided by the direct-to-the-door delivery of the truck, which makes this means of transportation not only quicker but also cheaper than rail. Only empty barrels are carried.

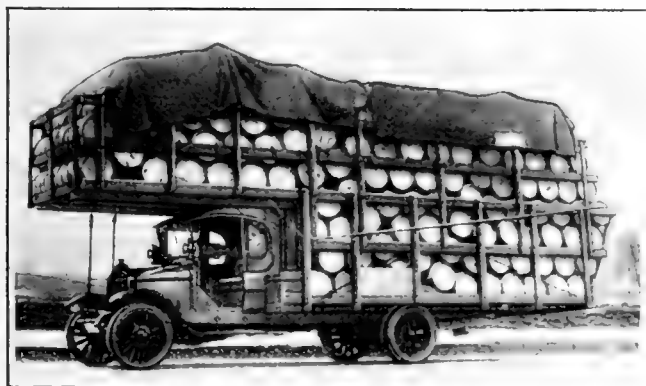

More barrels can be carried on this truck than in the largest freight-car

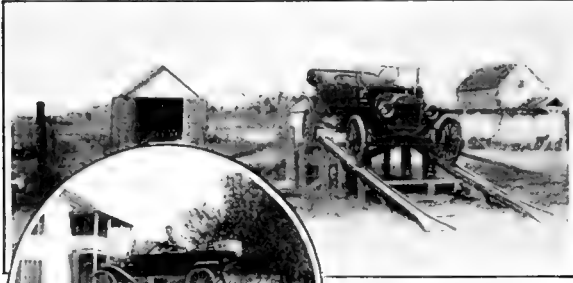

The inconvenience of stopping his machine to unlock the gate before entering his yard led this farmer to erect the overhead crossing here shown

### How One Ford Got Up in the World

FOR nine months a Florida farmer opened and closed his gate leading to his garage every time he took out his Ford for a spin. Then he built a runway which put the gate to shame. With

four pieces of eighteen-foot lumber two by four feet, eight pieces of one foot by three feet, and some short pieces two by four feet to form the supports, he had his runway constructed in short order at a cost of a few dollars.

Despite the fact that he has only the use of his right hand he steers his Ford on the runway with perfect ease. In addition to this he doesn't worry about the gate any more; and as for the pigs and cows that formerly played havoc with his garage furnishings, they belong to the troubled past.

The runway, as he constructed it, is strong enough to bear the combined weight of the automobile and its capacity load of five passengers. On wet, slippery days sand is sprinkled on the runway board to keep the machine from skidding. The side rims keep it on the track.

### A "Shoo-Fly" For a Candy Kitchen

TO KEEP the door of a candy store open and to have no obstruction such as a screen door in the way of those entering, gives the flies full freedom to the sweetened goods. One shop keeper devised a very simple and attractive means of keeping the little pests from the goods on the shelves. The store was on the corner and only two walls were open for shelving.

At the top end of each section two flanged wheels were fixed to turn in a horizontal plane and a ribbon band was run as a belt between each pair of these wheels.

These were connected with a small electric motor to turn at a moderate speed. The tape used for the belt made a ready means for attaching numerous ribbons in different colors so that they hung like streamers from the top of the shelves to the floor.

As the band traveled around the wheels these streamers were carried in a slanting position, sloping back at the bottom from the direction of travel. As the ones on the rear side were going in an opposite direction it produced a latticed effect and the moving of the

many ribbons kept the pests away. It produced a very attractive arrangement and many a passerby stopped to take a look at the moving colors.

The "Shoo-Fly" has also been used with great success to protect exposed fruit and vegetable stands, and has even been used for soda fountains.

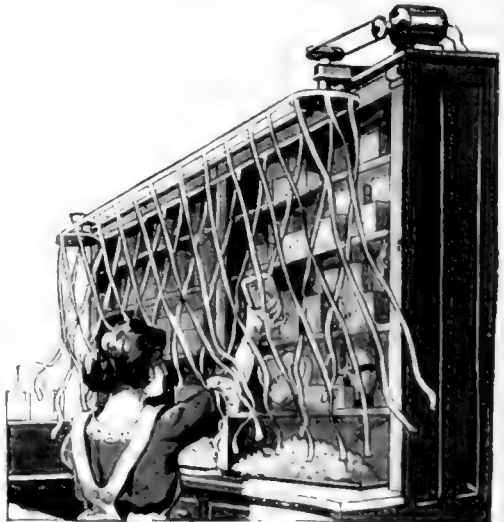

These colored streamers fluttering past the shelves of candy effectually prevent the invasion of flies



**T**HE work of building coffer-dams, or temporary dams, is often as ticklish and difficult as the larger and supposedly more important finished piece of construction which is impossible without the dams as a foundation.

The picture illustrates the placing of a section of the crib-work of a coffer-dam. Observe that the water is in almost flood state, because the natural channel of the river has been so much restricted by the already completed part of the work.

The cribs are built on dry land to very accurate measurements. When all is ready, each one is launched in its order. The methods of control, after launching, vary. In this case five steel wire cables of  $\frac{5}{8}$ -in. diameter rigidly connected with five winches, located at points on the river banks, were used to control the course of the cribs as they were placed. When a new section is brought in line with the already existing

A Ticklish Moment



If a cable should snap, the crib would be dashed to pieces on the rocks below the falls

the next section treated in like manner.

Something of the extent of the forces that have to be met with, due to the immense water pressure, may be gathered from the fact that during the placing of one of these cribs, one cable parted and the strain thus thrown upon the remaining four proved successively too much and they each in turn gave way. The crib meantime sailed gaily down stream, over the rocks and bumps of the falls below.

Where coffer-dams are thrown across deep channels of treacherous waters the work is fraught with the greatest danger, necessitating the most careful system of operations.

A Protecting Holder for an Open-Faced Watch

**W**E illustrate an original idea in a watch-holder for wearing upon the person, especially for ladies' use, in which the watch is invisible and is pulled down by a suitable pendant so as to allow the face to be seen. The illustration shows the holder as seen from the back, with the watch partly drawn down and out of the holder against the top spring. A crescent-shaped piece receives the watch when drawn up. The watch may be of special shaped as here shown, or a flat disk can be used to serve as a watch-carrier, with an ordinary watch fitted into it by clamps. In this case the disk works with the spring and the pendant, allowing any watch of proper size to be fitted into it and carried with safety.



To ascertain the time, simply pull the watch down out of its case. The spring will withdraw it when released

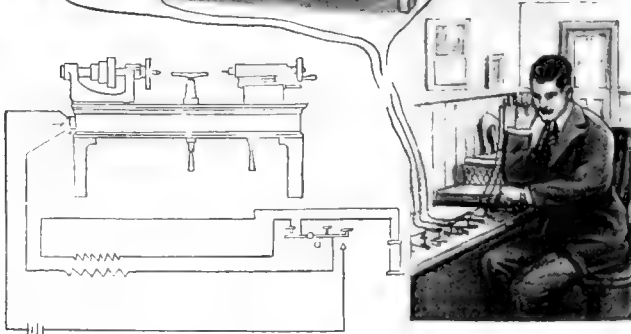
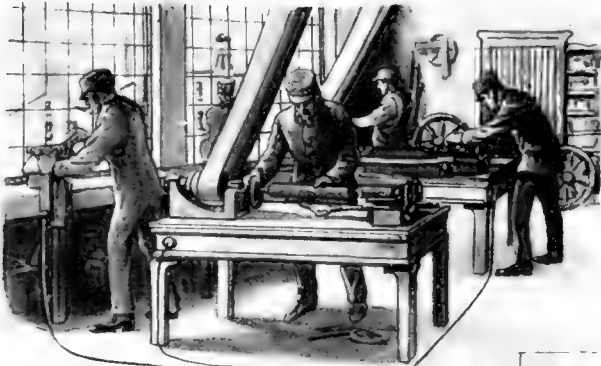

Strict accountability is enforced by the use of this machine

### Hearing Your Men at Work

THE manager of a machine shop or factory can know how much work is being done at benches by mechanics or by power-driven machines or tools by means of microphones or telephone transmitters connected with the working apparatus. By becoming familiar with the vibrations of the different machines he can tell at any given moment just how fast Pat is working the lathe, or how industriously Mike is operating the milling machine on one of his blue Mondays. In addition to this he can tell at a simple turn of the switch if the machines are running at normal speed and smoothly and properly, as they should.

### Interchangeable Pressing and Steaming Device for Tailors

A RECENTLY patented ironing-board for pressing and steaming garments is composed of a receptacle having a flange 11 around its open top. A hoop 13 presses upward against the gaskets 12 and downward against the short arms of several eccentric levers 14. This is shown in Fig. 2. Numerous

recesses 16 in the sides of the receptacle allow for the movement of the levers.

Two layers of fabric, the upper one air-tight and the lower one porous, are stretched over the top of the receptacle and secured under the flange by means of the hoop and gaskets. Within the receptacle is a longitudinally-placed conduit 19 having numerous openings. At one end steam may be admitted, and at the other end, air.

When pressing, air is admitted and its flow controlled so that a slightly rounded surface is obtained. The main advantage lies in the fact that shiny seams are avoided.

When steaming garments, the upper air-tight fabric should be removed. Steam can then be admitted instead of air. The porous

under layer allows the steam to pass through and the rounded surface affords very close contact for the garment, insuring a thorough steaming.

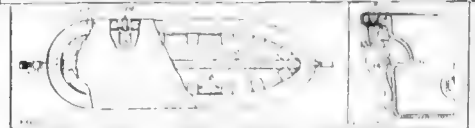

Shiny seams cannot result because the pressure is evenly distributed

**"Ironing Out" Earthquake Wrinkles in San Francisco**

AT the time of the earthquake many pavements of San Francisco "wrinkled" under the strain. Traffic since has increased the uneven surface. By the use of the machine shown in the picture, old pavements are made like new. A traction-engine is fitted with an oil-blast furnace and a hood by which a section of pavement from the curb to the car track is softened until it can be leveled by raking. Each section is then successively smoothed and rolled in the regulation way.

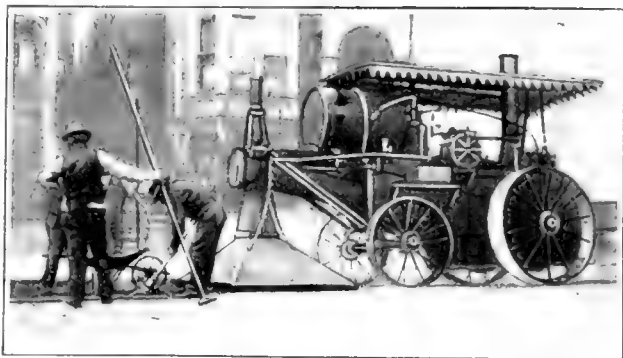

Intense heat from an oil-blast furnace is applied to breaks in the pavement so that it can be leveled

The most disastrous effects of the earthquake occurred in parts of the city where the ground consisted of "made" land, especially in a large area adjoining the Bay, which consisted originally of mud flats and overflowed lands built up with layers of sand, waste, and the like. Under the shaking of the earthquake, this soft ground tended to flow along the slopes, causing pavements and street-car tracks to break up or buckle. Here and there the ground was rolled into waves three or four feet high. Where the texture of the soil was very loose, the ground surface was lowered. What occurred in the latter case was just what happens when a measure into which

grain or loose sand has been poured is shaken in order to make it settle down. The shaking causes the particles to come closer together and the mass occupies less space. The rainfall had been much above the normal for three months before the earthquake, and the soil was therefore more soft and plastic than usual.

Many observers in the region visited by this memorable earthquake have furnished graphic descriptions of the visible undulations of the ground that formed a feature of it, especially in soft alluvial soils. The waves were from one to three feet in height, and their length, according to one description, was about sixty feet from crest to crest. Trees and telegraph-poles were seen to rise and fall as the billows of earth swept by.

**How Automobiles Innocently Break Windows**

WHEN a heavy automobile runs over pebbles no larger than a pea, a

pebble may be caught just right by the edge of the wheel and shot with such a high velocity that a broken window is the result. One firm in New York has had three windows broken, all in the same frame. The layout at this particular place is as indicated in the drawing.

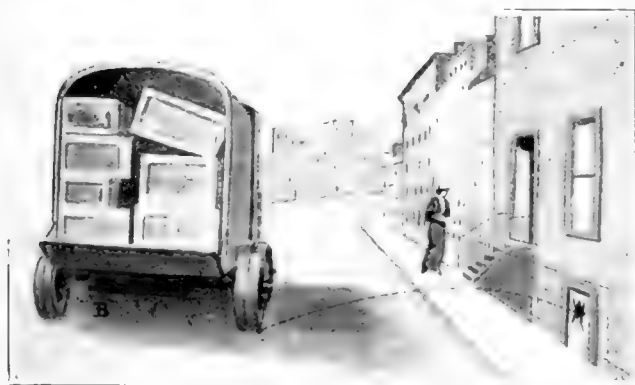

The heavy wheel of a motor-truck shoots pebbles that break unprotected windows

The principle involved is the same as that practiced in "shooting cherry stones" by pinching the slippery stones between the fingers. In this case, though, much higher velocities are attained because of the enormous loads now being placed on trucks.

# There's more to War than Shot and Shell



At left, Germans establishing a great army telephone exchange somewhere along the southeast Russian front. Below, oil-can, lantern and measuring cup - part of a German officer's outfit

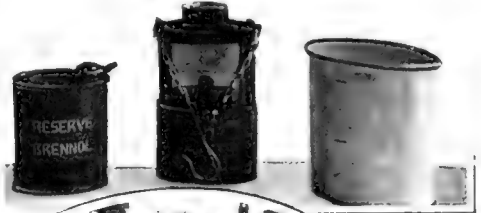

At the right are shown men developing and printing plans at the front, for the use of aviators and officers

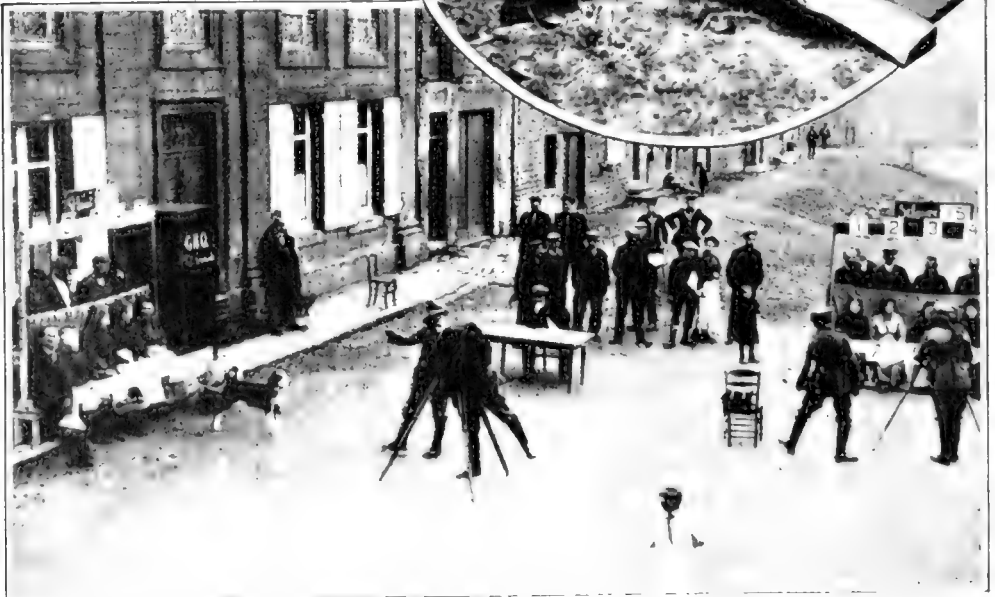

In Russian Poland, the German officers keep an accurate record of every peasant by means of his photograph. Ten pictures are taken at one sitting and then cut apart with their respective numbers. These are then filed with the military governor

## Refinements in War Motors



Motor-trucks equipped with searchlights have played an important rôle in the World War. They have multiplied in number until now hundreds are employed by each of the warring nations. Above is shown a high-power searchlight illuminating a road. The truck is of American design and manufacture

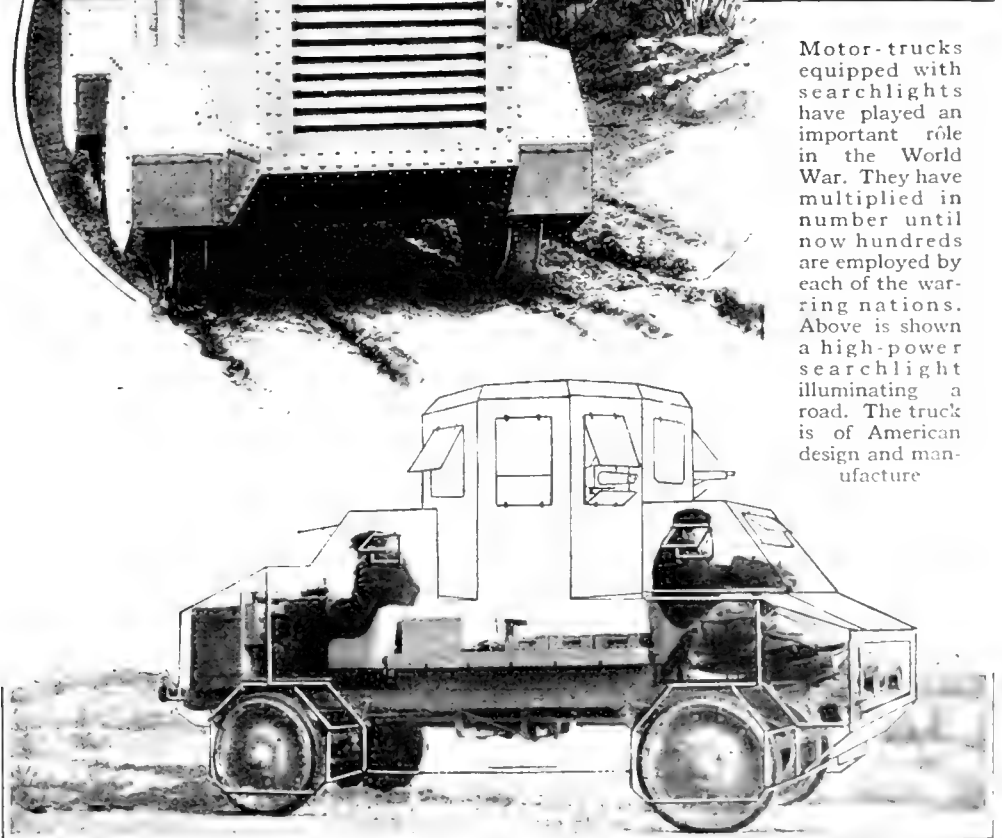

An American manufacturer has designed a truck operated from both ends. When beset by the enemy the crew need not turn around. The car fitted with an armor body is shown above at the left, while the stripped chassis may be seen below, the superstructure being drawn in faintly to show the positions of the drivers

# The David and the Goliath of the Skies



Copyrighted by American Press-Photo

One of the most remarkable photographs yet received from Europe. A German Zeppelin falling from the clouds after being hit by an explosive shell from the French aeroplane seen in the center of the picture. The photograph was taken from a German trench.

# A Gas Attack Seen from an Aeroplane

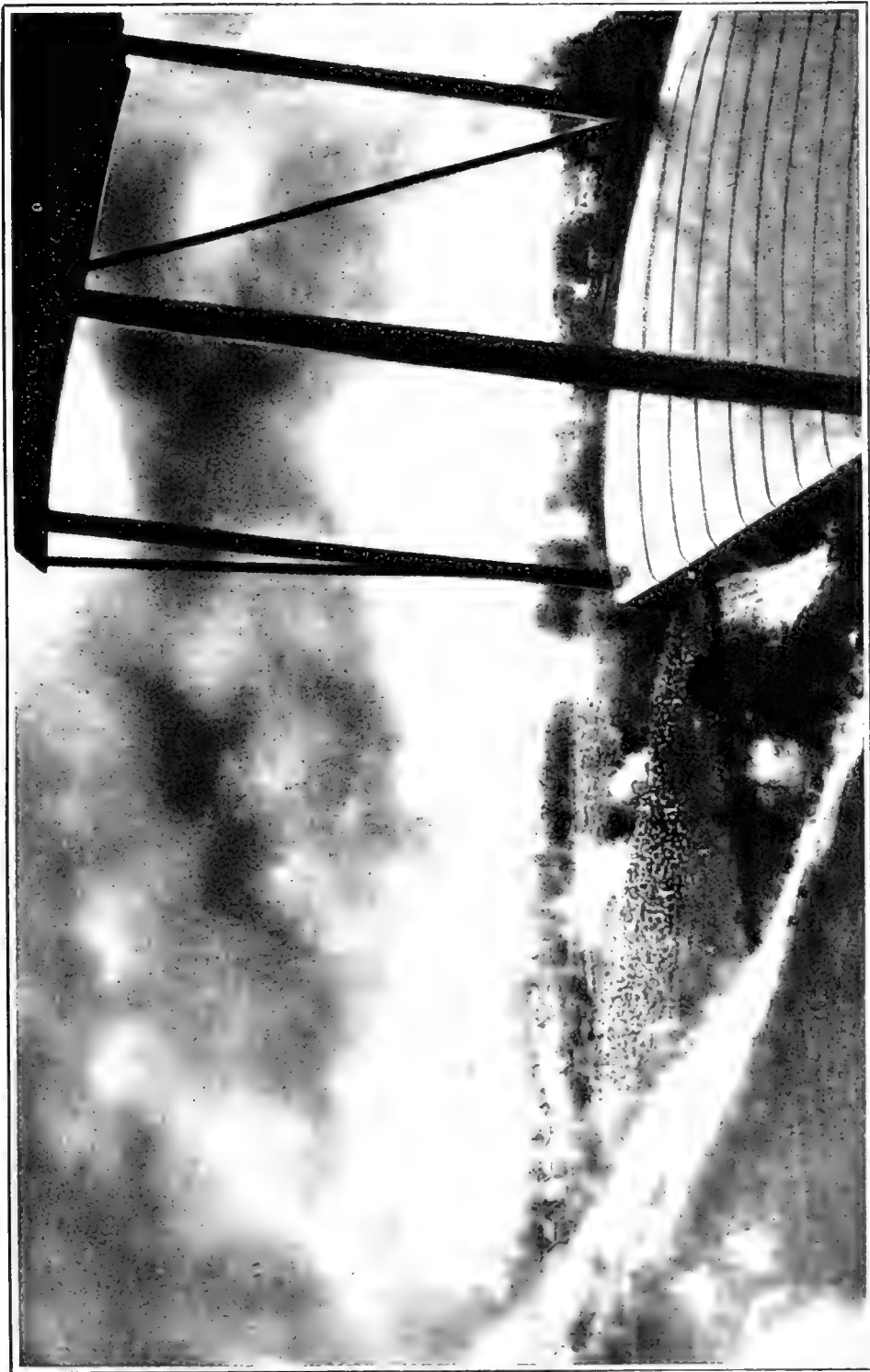

A remarkable photograph taken from a British aeroplane showing German troops massing behind a cloud of poisonous gases, blown toward the Allies. Shells fired by the Allies may be seen bursting within the German lines, and in the French village in the background



## New Activities of Military Surgeons

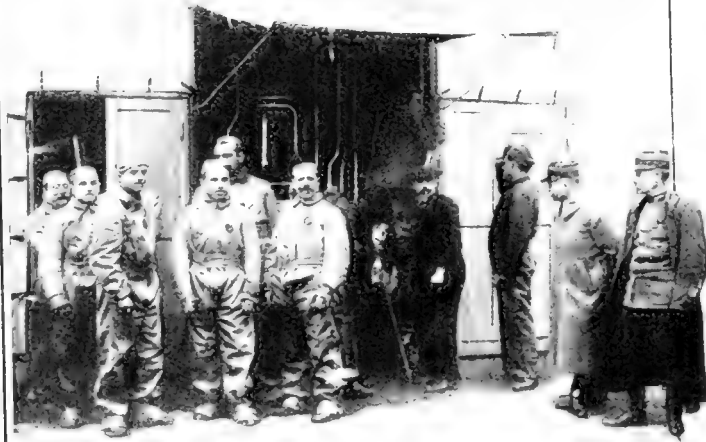

All the luxuries of a Turkish bath may be found in these tents, which have been recently presented to the French Army. A number of them are now to be found near the trenches. They are considered a boon by the officers and men

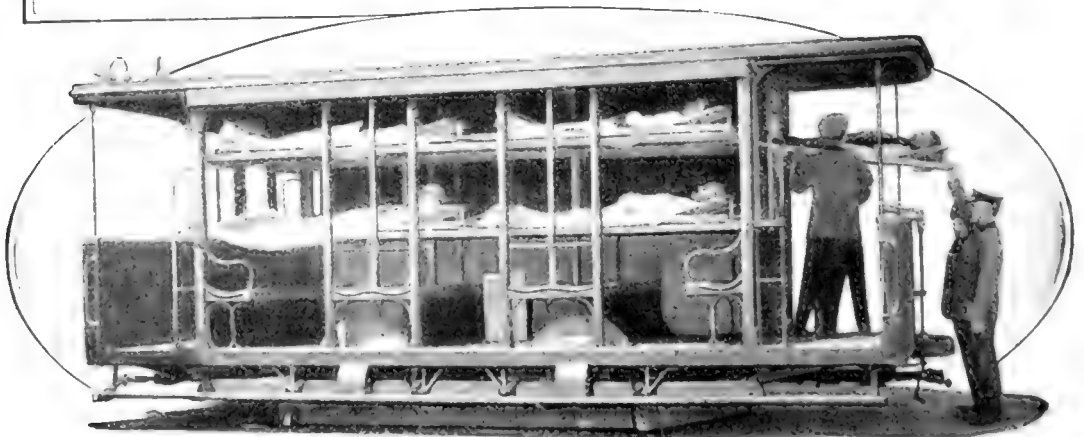

The versatile Germans are even using streetcars as ambulances. Capable of carrying eight stretchers, these cars take the sufferers from the railroad station at Dusseldorf to the base hospitals in comparative comfort



# Keeping the Germans from Verdun



A mistake in the handling of supplies during a great battle might easily result in defeat. Behind the French lines at Verdun, the work is carried on with accuracy and speed which are amazing

At right, a Giant 16-inch French shell, designed to rival the famous Austrian Skoda projectiles. The new French guns which fire these shells are manned by crews of sailors taken from the fleet

Below, the latest development in French armored motor-cars. The distinguishing feature is the use of two turrets for guns

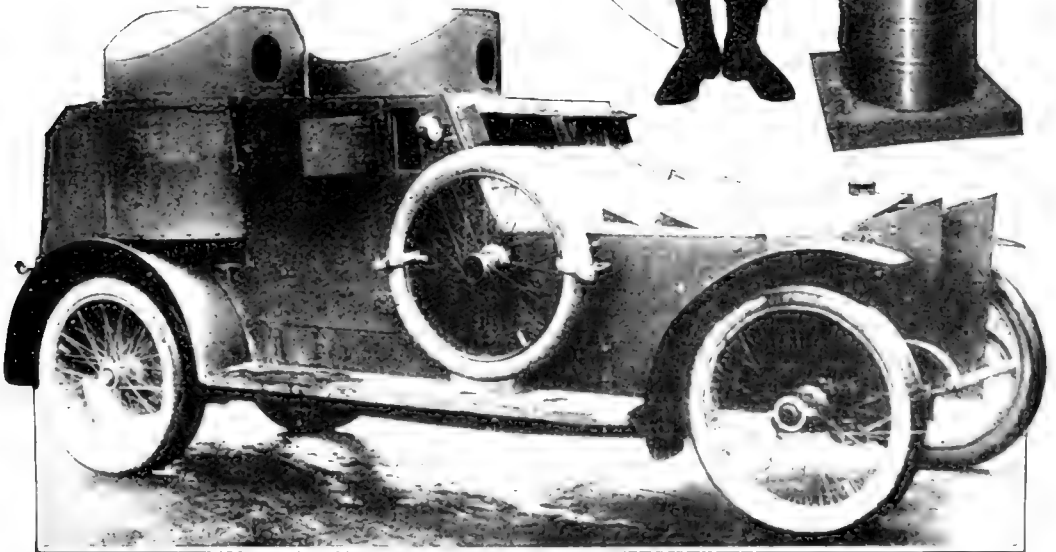

## What the Battle of Verdun Means to the Townspeople

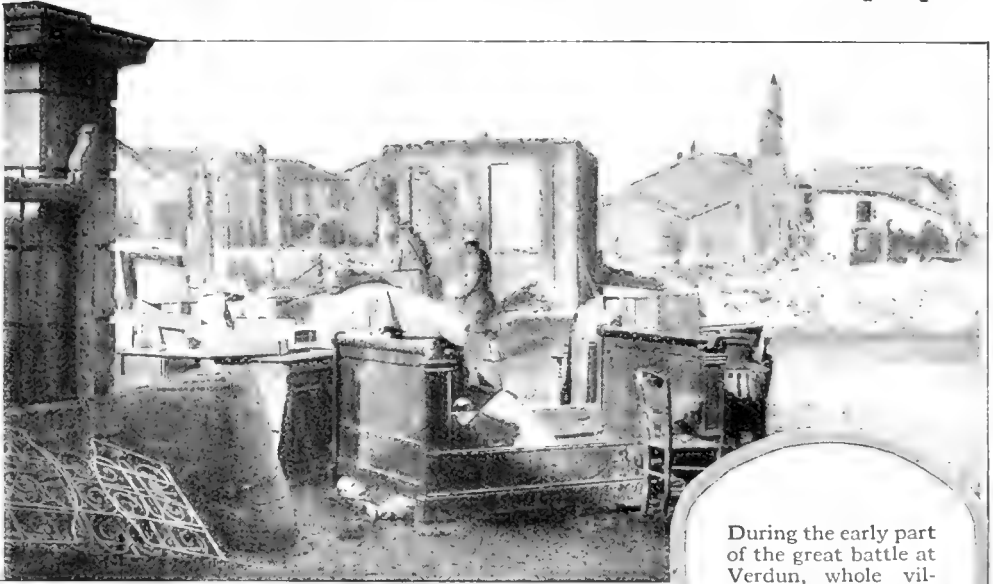

During the early part of the great battle at Verdun, whole villages were destroyed by the on-sweeping Germans before the inhabitants had time to save their household belongings

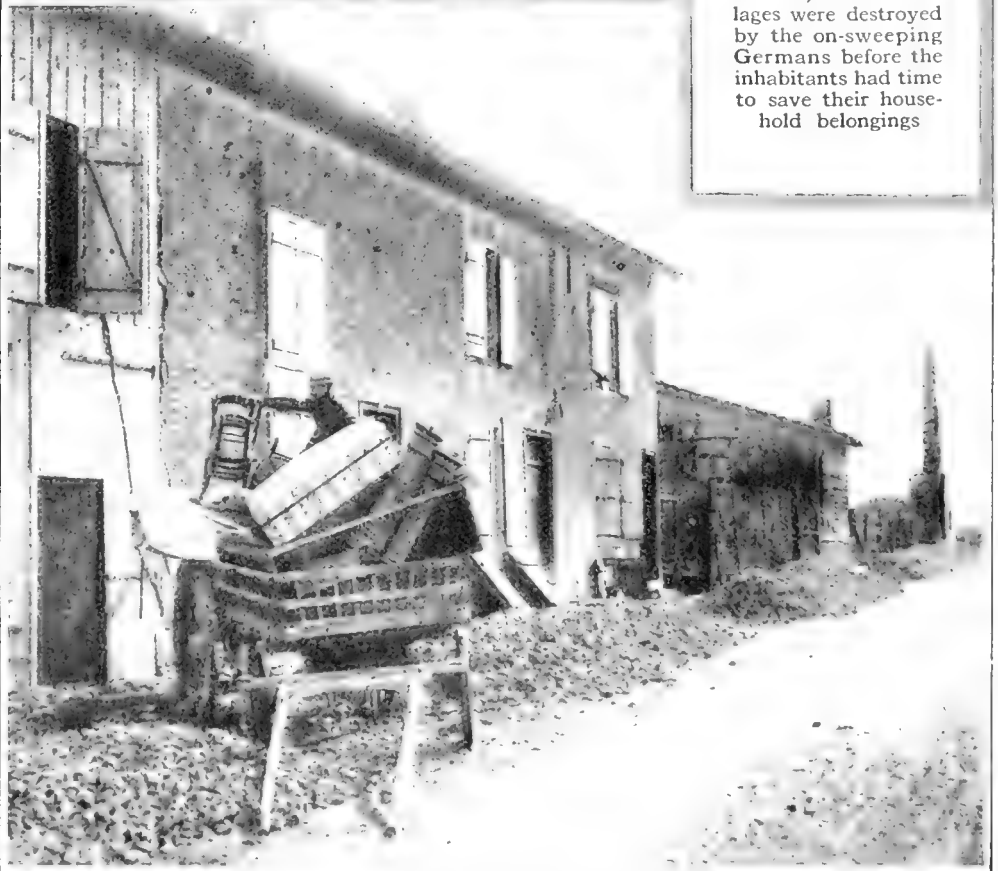

In the path of the German drive on Verdun troops aided the terror-stricken inhabitants in saving their property, often at great personal danger. After all the available horses were pressed into service, the wagons and carts were drawn to safety by hand

# From the World's Greatest Battle-Ground



At the scene of the world's greatest battle. Dummy-trench mortars behind the French lines at Verdun

A queer result of a high-explosive shell is shown to the right. In a French church a statue was struck by a shell. The statue was broken into fragments, but the head was hurled against the wall with such force that it was embedded in the masonry



In the great battle of Verdun, ammunition was fired in almost inconceivable quantities. Hundreds of motor-trucks, similar to those shown above dashed continually between the lines and the base of supplies, constantly replenishing ammunition and victuals

# Glimpses of the French Trenches



A passageway in the "Ravine of Death," a position disputed for many bloody months, and finally carried by the French at the points of their bayonets. The effect of German shell fire is evident enough in the torn and leafless trees

To the left, masked French soldiers emerging from a subterranean shelter



Something new in trench warfare is shown in the picture to the right. The French have named this strange weapon a "revolver gun," possibly because of a remote resemblance to the familiar "six-shooter"



# "Somewhere in France"

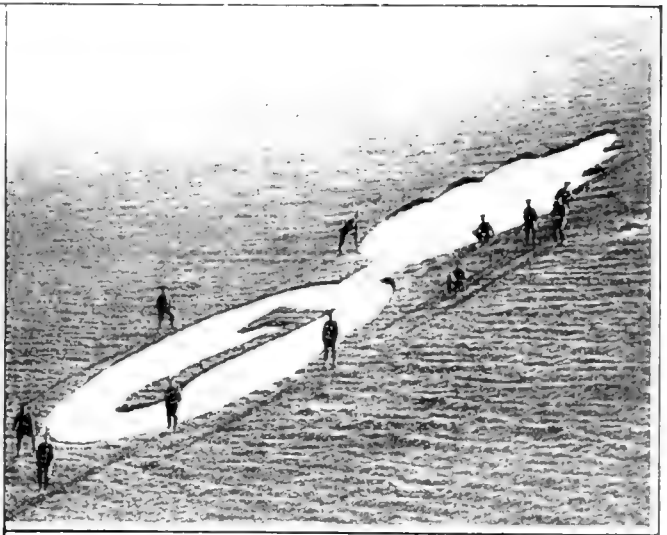

A regimental badge cut in a hillside on the first anniversary of the Seventh Battalion of the London Regiment

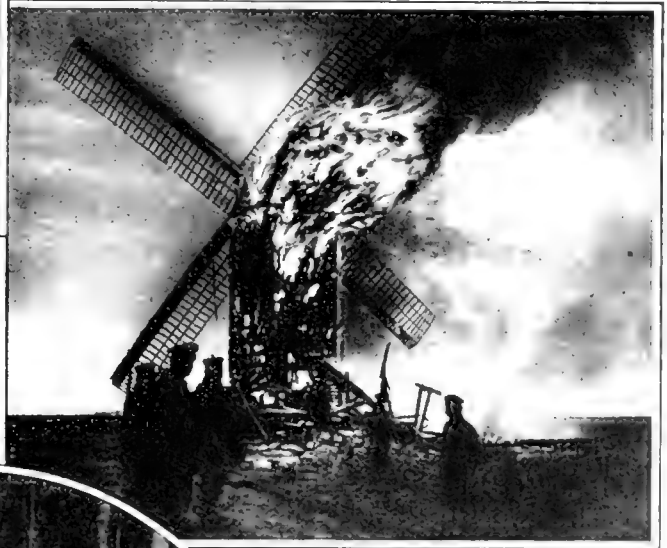

Above, bailing out a flooded German trench "somewhere in France." Below, French soldiers drawing their weekly ration of tobacco. One French general presented his troops with ten thousand cigars and cigarettes



Behind the battle line at night. This windmill was suspected of being a German observation post. One or two well-placed shells reduced the dangerous structure to a pile of smoldering ashes in a short time

## The War in the Clouds

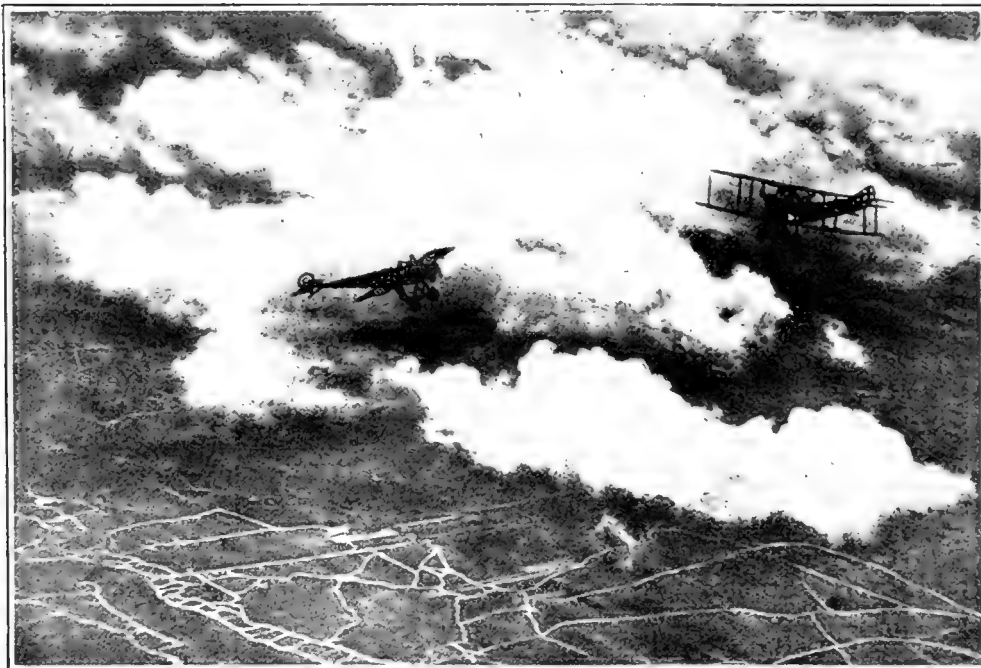

A battle in the air. An allied monoplane (on the left) rising to attack a German biplane among the clouds over the war front in France. The photograph was taken in mid-air by a third aeroplane, and shows clearly the trenches over which the machines are battling



An Austrian pilot balloon being inflated from a gas cylinder. These small pilot balloons are sent aloft just before a Zeppelin foray in order to determine the direction and velocity of the air currents. In time of peace they are employed to obtain temperature readings of the upper air for the use of meteorologists



# Rapid-Fire Guns and Their Victim

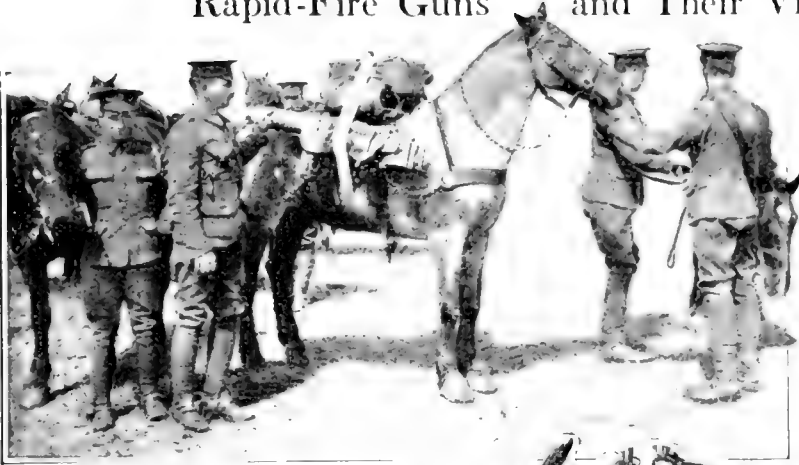

A new British machine-gun equipped for cavalry work. The gun is extremely light, and may be easily carried on the back of one horse. In an emergency it may be assembled for action in a very few minutes

At right, the first of the famous Fokker monoplanes to fall into the French lines. These light and speedy machines played havoc with the Allied air forces. They are little different from the familiar French Morane except that they are overpowered, thus gaining great speed

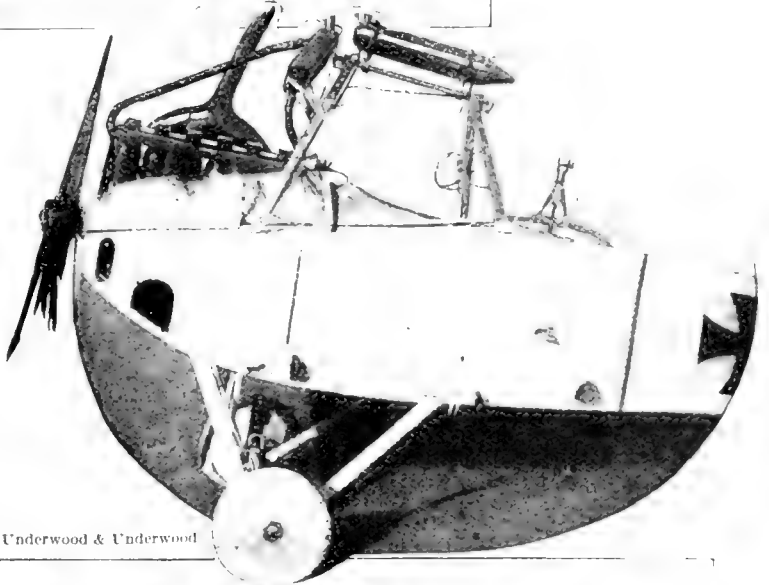

© Underwood & Underwood

Below, the warning cry "A Taube" sending the men of the anti-aircraft automobile crews sprinting to their cars. The motor-cars are equipped with high-angle rapid-fire guns



© International Film Service

## Overcoming Difficulties in Albania



Austrian engineers making use of an old Turkish bridge in Albania by erecting a temporary wooden roadway

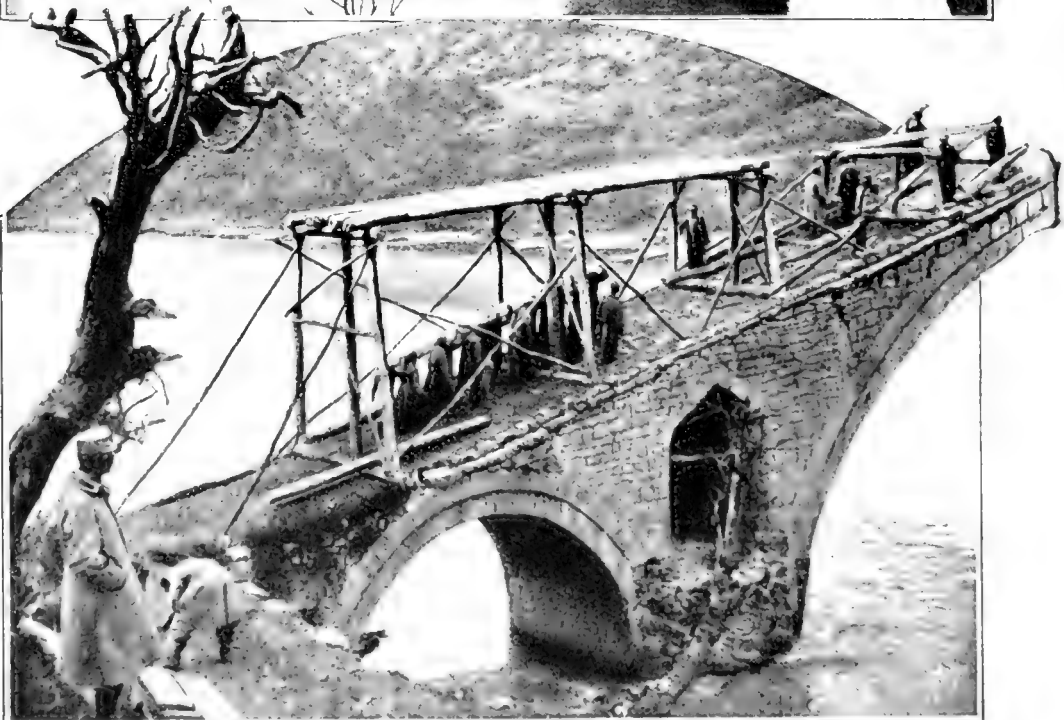

© International Film Service

This picture shows the bridge in the foregoing illustration in course of construction. Obviously the purpose was to get rid of the picturesque but awkward inclines as well as to repair damage



# On the High Seas with the Battleships

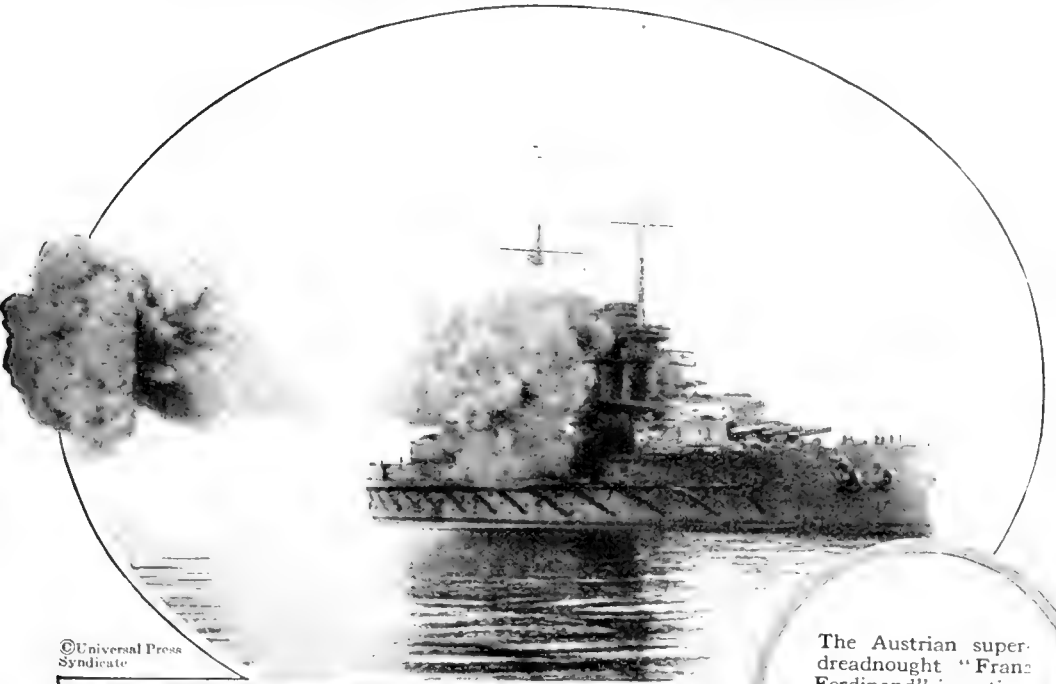

©Universal Press  
Syndicate

The Austrian super-dreadnought "Franz Ferdinand" in action. This late type has three-gun turrets similar to the latest ships of the American Navy



© in U. S. and Canada by American Press Assn.

A battle between a British dreadnought and a German raider in the North Sea. The reddish gases of smokeless powder photograph black. Hence the black clouds

# America's Monument to Her



© Underwood and Underwood, N. Y.

Above, the fleet of should have been caused a long delay had to advertise for Europe, thousands

motor supply-cars with which the United States Army provided years ago. The lack of such vehicles in crossing the Mexican border. The army officials motor-trucks. On the night that war was declared in of motor-trucks were on their way to each strategical point

Below, one of our ment which com- This kitchen

© Underwood and Underwood, N. Y.

crude field kitchens. Another item of American equip- pares very unfavorably with that in the European armies. is heavy, cumbersome, and cannot be used en route

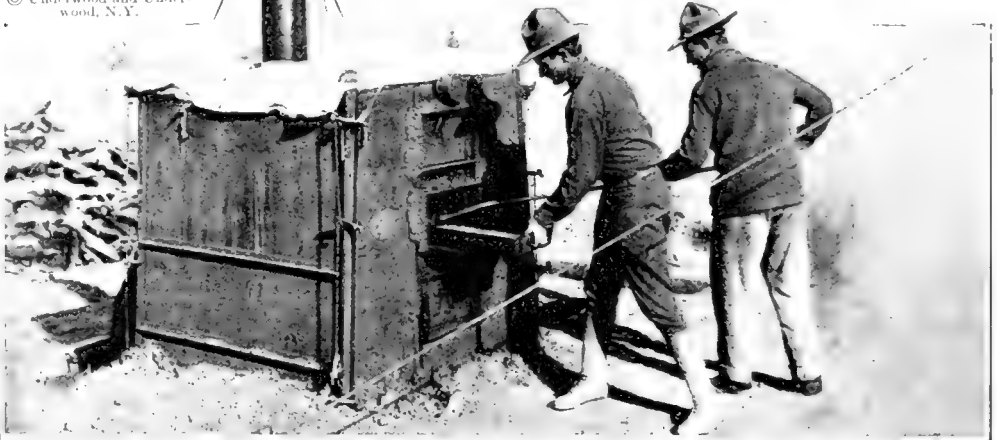

© International Film Service

A system of signaling borrowed from the Indians. A squad from Troop E, Twelfth United States Cavalry, sending up a smoke signal to apprise the rear guard of their position. In the wide expanses of Mexico, where the human eye can detect with remarkable accuracy objects fifty to seventy-five miles away, the smoke signal represents the most effective means of giving information when wireless and telephone are not available

# Policy of Unpreparedness

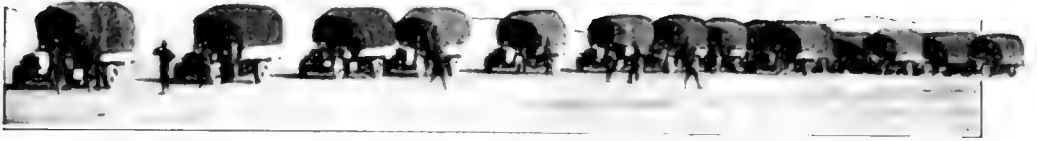

© Underwood and Underwood, N. Y.



At the end of a six days' march southward into Mexico. With the limited forces and inadequate equipment at their disposal, the United States troops have acquitted themselves very creditably. The truck shown is equipped with flanged steel rims fitted over the wheels. It can run on the railroad tracks, and with but slight alterations can again take to the roads. Several of these versatile vehicles were recently forwarded to our army at Columbus, New Mexico

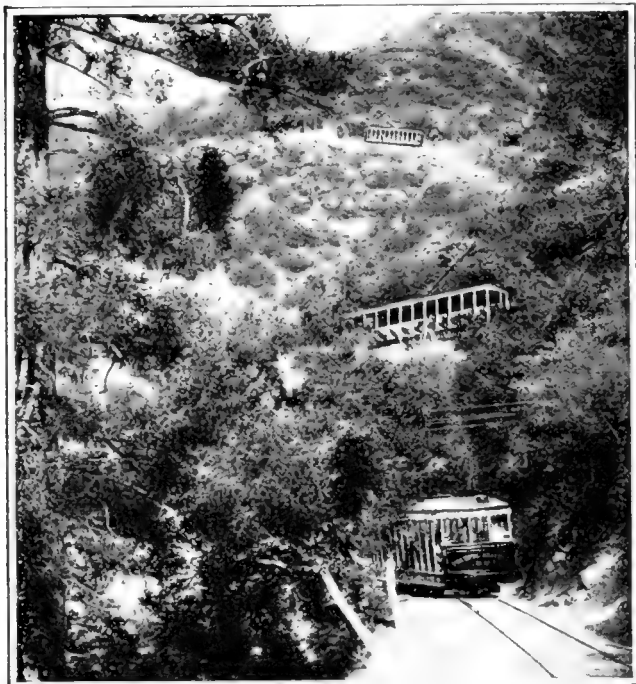

Three levels of track are visible in the zig-zag course up the precipitous mountain side

### Hairpin Curves on a Mountain Trolley Line

**T**HERE is an electric trolley trip up the face of Mount Lowe in Southern California, which, so Europeans have said, equals in thrills and actual interest any of the Alpine or similar jaunts in Europe.

The start is made in an ordinary surface car, which tackles the massive base of the Sierra Madre range by a succession of violent curves, then pursues at a modified clip a series of hairpin turns, which are perfectly safe, although it seems that the car must be hanging on by its very eyebrows at times.

At one particular point in the journey, where the car weaves in and out as it climbs its zig-zag course up the mountain side, three cars may be seen at one time, one directly above the other on the various levels.

Far to the south, as the car ascends, the blue chain of the Temecula Range rises up from the valley. Villages, farms, ranches take on a strangely dissembled and isolated appearance.

The last stop of the car is made at Echo Mountain, where at night a five-

foot searchlight throws a questioning shaft of light into the depths below. Close at hand is the Mt. Lowe astronomical observatory, which is opened several evenings in the week to visitors.

### How an Automobile-Engine Tests Water-Mains

**B**Y means of a centrifugal pump driven by an automobile-engine new water-mains are being tested in Chicago. The work was formerly done by a triplex pump driven by a gasoline-engine, all mounted on a wagon. As most of the pipe-laying is in the outskirts of the city a twenty-five mile drive with a team at six dollars a day to cover one job was not infrequent.

With the new automobile apparatus it is now possible to cover four or five jobs per day in different parts of the city. The number of tests has been increased one hundred and fifty per cent, and practically all jobs are tested. The pump was specially designed for the purpose and rests in a horizontal position. It is driven by the truck through an extra sprocket and a silent chain without any reduction from the speed of the engine. Two men make the tests. One operates the engine and the other reads the meter.



The automobile-engine drives a centrifugal pump, testing water-mains in a minimum of time

# Your Mainsail and the Wind

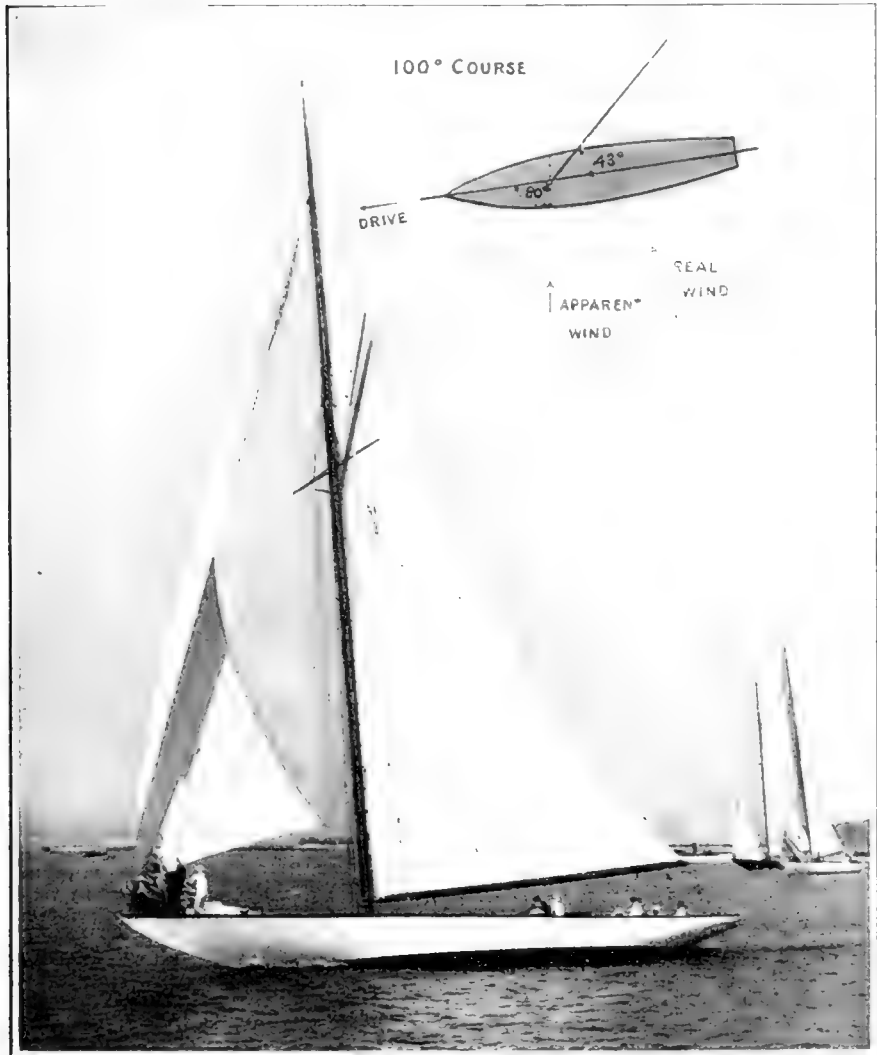

Photo by Levick

The boom makes an angle with the boat to secure the highest possible speed

**A**N interesting and practical series of experiments in a field that is new to science has been made at the Massachusetts Institute of Technology by Professor H. A. Everett, for the purpose of determining some of the facts about the propelling power of sails. By dint of experience and by rule of thumb certain practices are common in sailing boats. Skippers agree in the main about these practices,

but there are individual variations from any rule. Each man maintains and asserts that his is the proper way. What Professor Everett has done is to determine scientifically certain elements common to all sails with regard to thrust or propelling power, and twist, and to establish certain fundamental principles which fix the relations of sails to direction of the wind.

In Boston Professor Everett was

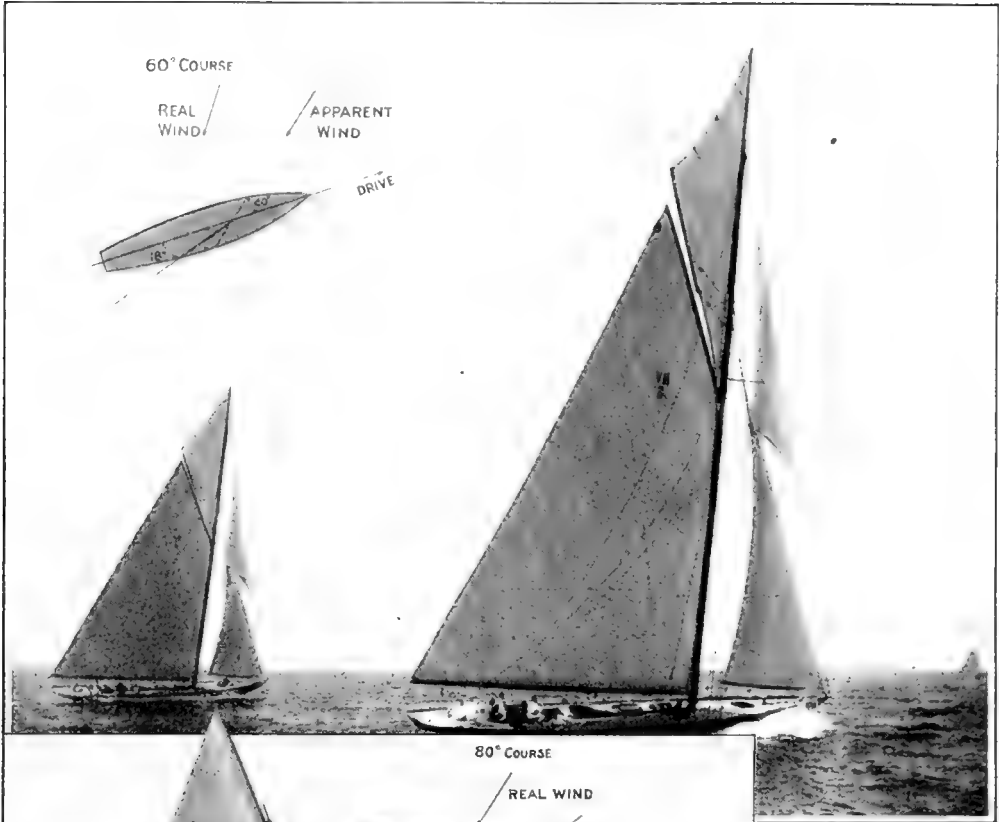

Photos by Levick

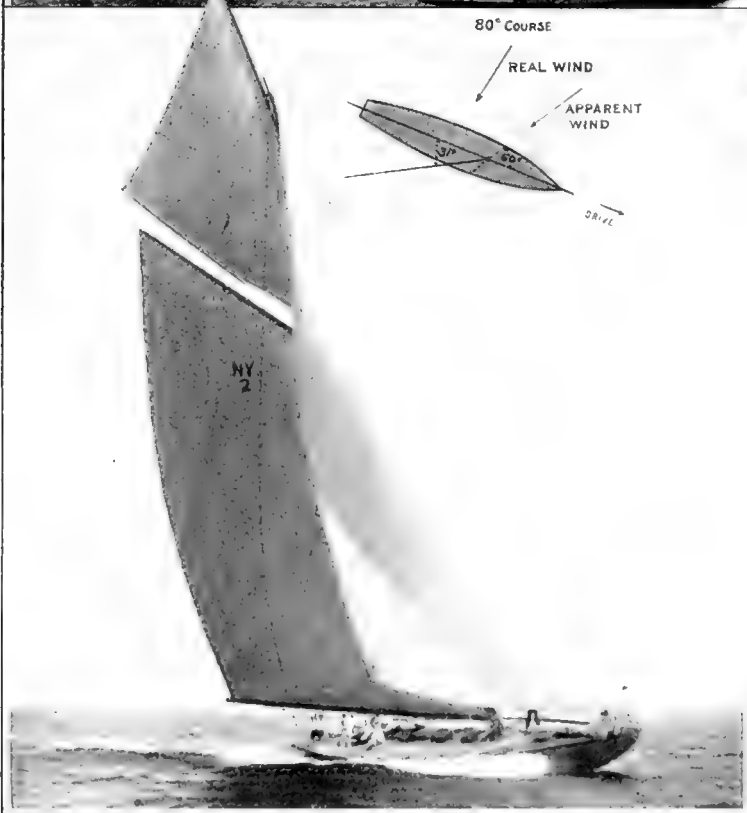

The wind which is customarily observed is that indicated by the fly at the masthead. The fly generally shows the skipper the apparent direction in which the wind is blowing. Professor Everett made experiments in a wind tunnel which show that yachtsmen do not fully appreciate the mechanical forces at work

The apparent wind is the resultant of the speed of the boat and the true wind

Assuming that the hull resistance is not affected by different angles of keel, the course at  $190^\circ$  with the wind is the one in which the boat will make the fastest headway. In the wind tunnel of the laboratory the construction is such that uniformly moving currents of air without swirls in them blow against the object tested. The mast with its sail is set up within the tunnel, and the effect of the wind in the sail is measured. The sail is set at different angles to the direction of the current of air

For courses from  $45^\circ$  to  $160^\circ$  the angle between the boom and center line of ship should be one-half the angle between the fly and center line of ship. In the wind tunnel measurements are made at each angle of the direction of the current of air. The thrust and twist are measured, the experiments being repeated many times with different wind velocities. It is the apparent direction of the wind that concerns the sailing man

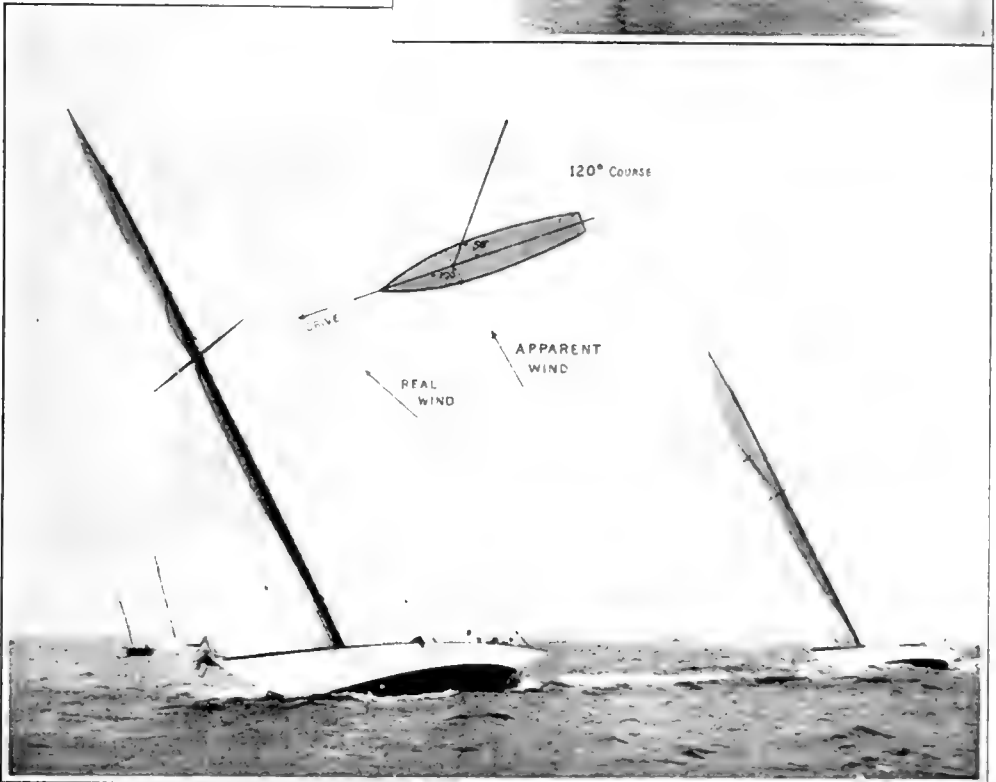

Photos by Levick

much in demand by naval organizations. Since last September he has been professor at the United States Naval Academy at Annapolis.

The underlying reason for the experiments was that the Institute has within three or four years established courses in aerodynamics, for the purpose of familiarizing young men with the design and construction of aeroplanes and airships. For the laboratory work in connection with these courses the Institute has had installed a wind-tunnel and accompanying equipment.

The tunnel is one of the important ones of the world and is equipped with an "aerodynamic balance" unique in this country. There is only one like it in the world. The Institute is therefore prepared to work on the scientific features of wind-currents. Hitherto such tunnels have been employed for the testing of propellers and determining the pressures on bodies of different shapes. The knowledge thus gained is of great assistance in making airships of the least resistant form.

Professor Everett hit on the idea of using this tunnel to discover what is the effect on a sail when subjected to different winds. He has been able to tell where the center of pressure is located in a sail, the amount of pressure for a given wind velocity and the angle which the boom should make with the longitudinal axis of a boat.

The experiments were made with a single sail, a mainsail, copied exactly on

a scale of  $\frac{3}{8}$  of an inch to the foot from a winning model of last season. The original was known to be a successful pattern and the miniature sail was carefully cut and made in precisely the same proportions as the large pattern.

In the experiments no attempt was made to reproduce the deck above which the sail would hang. Nor was a jib used. Either of these would have introduced disturbances in the nature of deflections of the air-current, which would have injured the chance of getting accurate results.

Another variation from natural conditions in sailing was that the boom was fastened to the mast, but the gaff or upper boom was free to swing off into any angle to which the wind drove it. The sail was set by two halyards as on a yacht. It was attached to the boom and gaff by

lacings, and the inner edge or luff was held in place against the mast by small brass rings.

In the wind-tunnel of the laboratory the construction is such that uniformly moving currents of air without swirls in them blow against the object tested. The mast with its sail was set up within the tunnel, and the effect of the wind on the sail was measured. The sail was set at different angles to the direction of the currents of air, and measurements were made at each angle.

It was shown that the angle between the boom and center line should be about half the angle between the fly and center line.

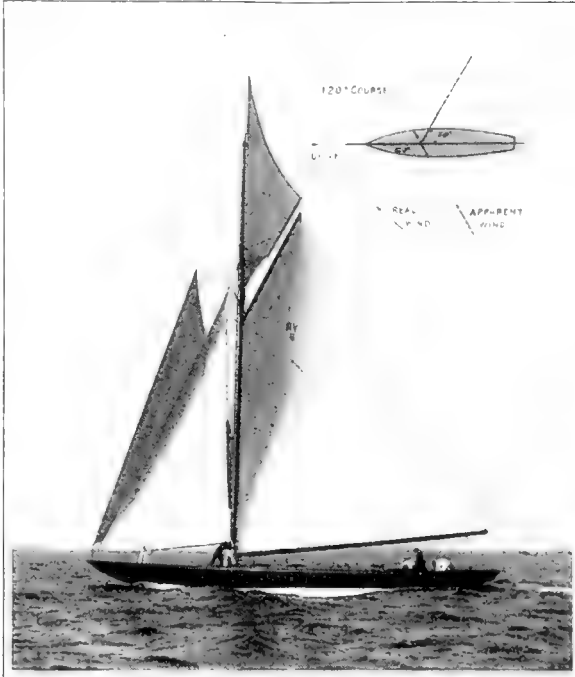

Photo by Lovick

Here the distinction between real wind and apparent wind is very close



### An Inverted Steam-Hammer for Drawing Piles

THE time required for drawing sheet steel piling is reduced to seconds by the use of an inverted steam-hammer. Two hundred and seventy-five upward blows per minute, with an 83½-in. stroke are able to remove piles in less time than it takes to drive them. This has been proved. The building of the new warehouse for the Pittsburgh and Lake Erie Railroad necessitated the use of coffer-dams for constructing the foundations. Concrete five feet thick was poured directly against the piling, with no intervening material to prevent adhesion. In this case, ninety seconds was the average time required for drawing these 35-foot piles, which was a minute less than the time used in driving.

The hammer which does this rapid work is suspended from the crane by a heavy wire cable. A massive strap of steel passes around the anvil block in the form of a loop, the ends uniting below for attachment to the pile. A rubber tube conveys the supply of steam from the crane.

The inverted hammer was also employed in the construction of the Lexington Avenue subway in New York city, with a great saving of time. Not only is the work hastened, but the piles are kept in good condition, being ready for redriving as soon as pulled.

### Six Battleships Go Into Reserve

THE navy department announced recently that six of the older battleships of the Atlantic fleet have been ordered into reserve. They are the *Nebraska*, *New Jersey*, *Rhode Island* and *Virginia* at the Boston Navy Yard and the *Louisiana* at the Norfolk Navy Yard. Lack of men was admitted to be the reason for this unusual measure.

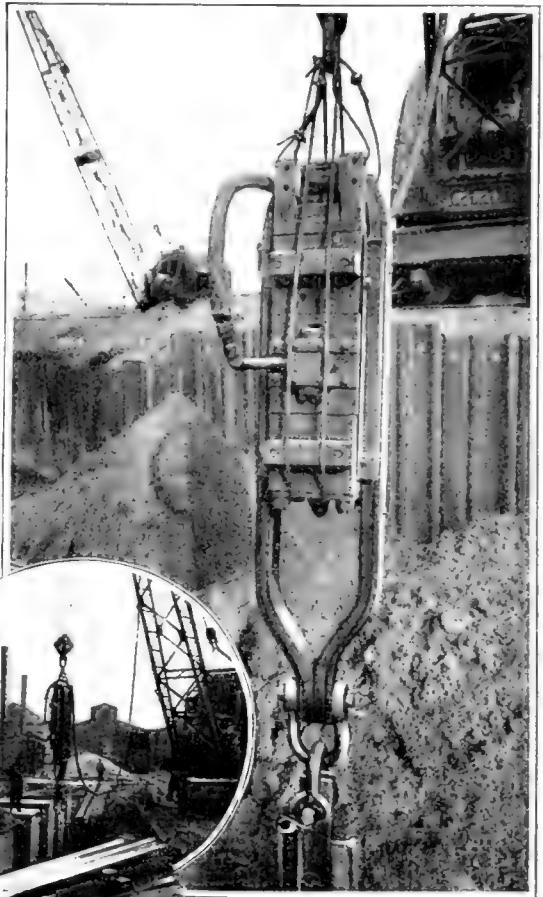

Piles can be drawn in less time than it takes to drive them with this inverted steam-hammer

### When the Fighting Man Dreams

THE harmony of the sleep of the exhausted soldier has but one discordant note, and that is the dream of battle," declares Dr. George W. Crile. ("A Mechanistic View of War and Peace." The Macmillan Company.) "The dream is always the same, always of the enemy. In the hospital wards, battle nightmares were common, and severely wounded men would often spring out of their beds. An unexpected analogy to this battle nightmare was found in the anesthetic dreams. Precisely the same battle nightmare that occurred in sleep occurred when soldiers were going under or coming out of anesthesia, when they would often struggle valiantly against the enemy's surprise attack."

# Saving Hours in Handling New York Subway Dirt

The new method of removing rock from subway excavations is accomplished in one fifth the time it formerly required. It loads the buckets directly from subway level to automobile trailer



ELECTRIC LOCOMOTIVE CRANE

OVERHEAD PLATFORM

TACKLE FOR RAISING BRIDGE

SIX LOADED CARS ON UPPER LEVEL RUN DOWN ON TRACTOR BY GRAVITY

CRANE PICKS UP EMPTY CAR THUS, AND LOWERS IT INTO THE SHAFT

STREET LEVEL

SUBWAY WORK

LOADED CARS PUSHED ON RAILS TO SHAFT

**D**OING in five minutes the same work that formerly took twenty-five minutes to perform, the method of handling rock from subway excavations illustrated here-

with is one of the most effective systems ever devised. It is in use at three points along the subway route in New York city. It has made possible the employment of huge fifteen-ton motor-tractor and trailer units and has speeded up the entire work of getting the excavated material out of the ground.

The system consists of an elevated platform set up on wooden bents on opposite sides of the street directly adjacent to the shaft leading down into the cut, an electric crane on top of this platform, and a double-decked stand on

the street beneath it with an adjustable draw-bridge pivoted at one end to a permanent bumper to which

buckets are rolled down on it by gravity. The free end of the drawbridge is then raised to a level with the top of the double-decked platform and the loaded buckets run down it on tracks on to the trailer, which is then ready to leave for the dump.

This entire operation takes five minutes. By the old method it took twenty-five minutes. The large saving has been made by having the load ready when the vehicle returns to the platform. The use of buckets with wheels has made possible the quick loading on the surface. They have also eliminated the congestion at the shaft bottom when ordinary buckets loaded on mine flat-cars were used because these, when empty, had to be kept near the bottom of the shaft until an empty bucket was lowered from the motor vehicle, meantime held idle. The new system has reduced danger to a minimum and no accidents have yet been directly attributable to it. Thus speed and safety have been combined in this newest method of subway excavation.

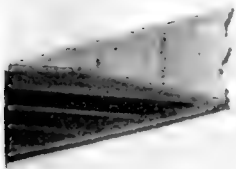

SIX EMPTY CARS RUN OFF TRACTOR BY GRAVITY BRIDGE LOWERED AS SHOWN

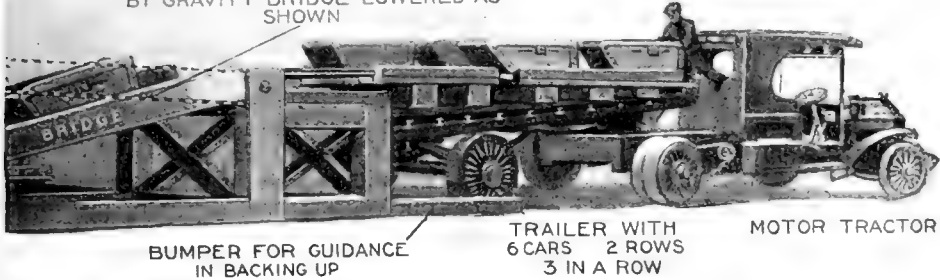

BUMPER FOR GUIDANCE IN BACKING UP

TRAILER WITH 6 CARS 2 ROWS 3 IN A ROW

MOTOR TRACTOR

Only five minutes are needed to carry the loaded buckets from the cut to an overhead platform and load them on to a motor-truck

the motor-trailers are backed. The buckets used are mounted on wheels. They are loaded in the cut and then moved on tracks to the foot of the shaft where they are picked up by the electric crane and hoisted one at a time and deposited on tracks on top of the double-decked platform. By the time six of the loaded buckets are thus placed, the tractor unit has returned from the dump with its load of six empty buckets, which are carried on tracks on the trailer. After the trailer has been backed up to the bumper, the adjustable drawbridge is tilted from the top of the bumper to the level of the lower platform, and the

### A Workshop on Every Farm

ACCORDING to one of the heads of a western agricultural college a source of economy that has been neglected in the past is the upkeep of farm tools and implements. To overcome this depreciation a workshop should be erected. It need not be large, but sufficiently roomy to allow for a workbench, a stove, and a certain amount of floor space where the machinery or tools may be repaired or taken apart and re-assembled. This will provide a proper housing for all tools and implements as well as a storage for defective and broken parts.



An ugly rock transformed into a beautiful flower-bed

#### A Flower-Bed on Top of a Rock

**T**RANSFORMING the unsightly rocks in your yard into flower-beds is not such a difficult task as one might think. Providing nature has been kind enough to hollow out the top of the rock or make it sufficiently level so you can build a bed of fresh earth on it, all you

need to complete the task is a few pointed stones, some cement and the seeds of your favorite flower.

The accompanying photograph shows how one rock was turned into a thing of beauty. Nature had been kind in this instance and the top was hollowed out deep enough to contain all the earth needed. Then the mother and son who thought of the novel plan obtained some cement and pointed stones and enclosed the earth with a miniature

picket-fence. Petunias were planted and with constant care, probably with more care than an ordinary flower-bed would need, they grew into a luxuriant lot of flowers. When the petunias lost their beauty rose-bushes were planted and they thrived as their predecessors.

#### A Unique Garden-Hose Holder

**A**LITTLE time and work saver in the form of a hose-holding device is shown in the accompanying illustration. Its purpose is to hold the hose, while sprinkling the lawn or flowers, in any desired position, thereby doing away with the tedious process of hand sprinkling. There is a flat, circular metal base out of which rises a sheet-iron standard, having openings at the top and the bottom. Outward from the top of the lower opening in the standard extends a tempered-steel spring, while through the opening at the top is a strip of sheet-iron, along the bottom of which is a series of notches. To the outer end of this strip are fastened the ends of a wire loop, which also runs through the outer end of the spring.

To operate, the nozzle end of the hose is inserted through the opening at the lower end of the standard and is continued on below the spring and through the wire loop at its end. It is then in position shown in the lower picture. To bring the hose to the position shown in the upper illustration, the operator simply grasps the end of the upper notched strip and draws it through the

opening in the standard. When the desired position is reached a notch in the strip is dropped over a nail in the standard. The pressure of the spring serves to keep the adjustment securely notched. This device is practical and, being made entirely of metal and of simple construction, it is durable.

The hose is held rigidly in position and will not move under the stress of ordinary pressure

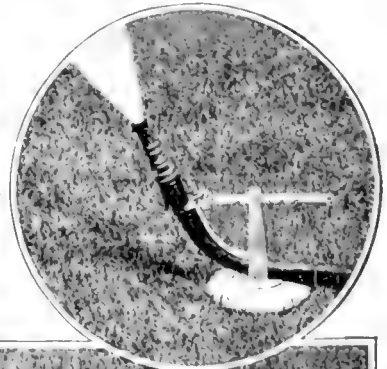

A single adjustment for holding a hose in any desired position

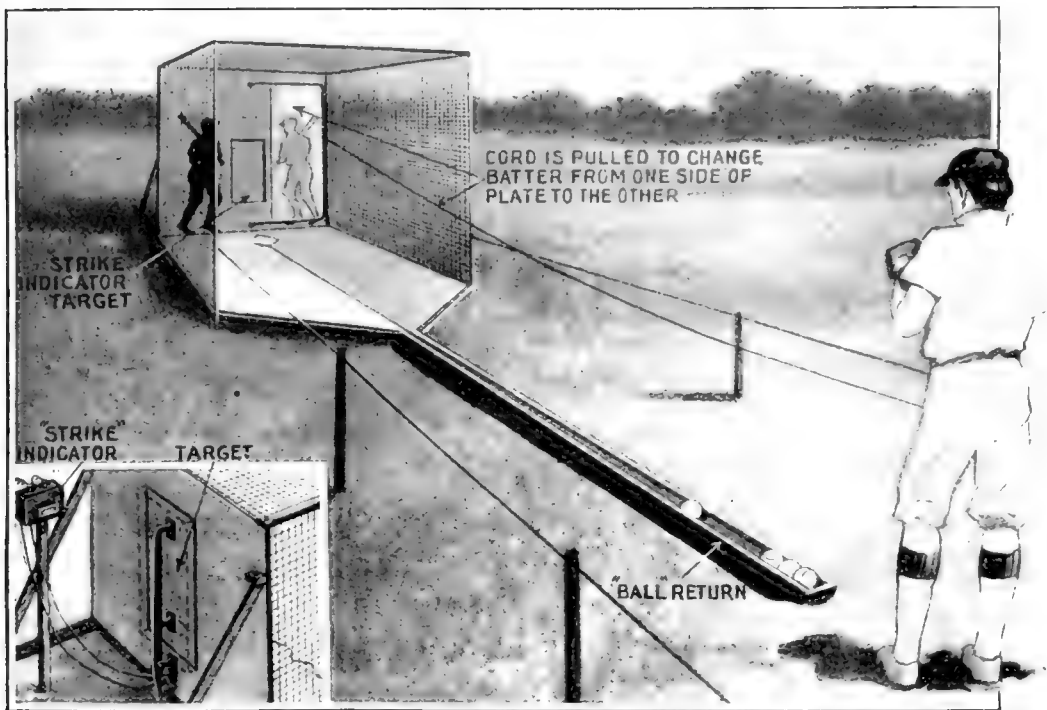

"The automatic umpire," as the inventor of this contrivance for training pitchers has christened it, has a target the exact size of the "strike" area. If the pitcher makes a "strike," the target is driven back a little—enough, as shown in the insert, to complete an electric circuit and operate a "strike" indicator. If the pitcher fails to hit the target, the indicator is not operated. In either case the ball is returned by a trough. Black silhouettes of batters are painted on either side of the target. Either of them can be concealed by pulling a cord which operates a swinging panel. Thus the pitcher is trained to cope with both right and left-handed batters. In the illustration the concealed batter is shown faintly behind the swinging panel, although the figure is not actually seen by the pitcher—this for the sake of making the invention clearer

## Playing Baseball by Machine

EVERY subject of popular interest is an inspiration for the inventor. It is, therefore, natural to expect that baseball would spur the man of wheels and springs, cogs, levers and gears, to many efforts, resulting in a large number of inventions relating to the Great American Game.

Outside of those which relate specifically to the sport as practiced—patents on balls, gloves, protectors, masks, spikes, bags, marking apparatus and similar things, mechanical baseball inventions divide themselves roughly into three classes. These are—games which simulate the great game itself, and which are supposed to provide at least a modicum of the thrills of the real

diamond, and which can be played upon lawn or in parlor—games or sports based on baseball which are suitable for country fairs, circuses, midways and similar places, in which the public participates either as batter or as pitcher, and finally, inventions designed to aid in the actual training of ball players, by making their practice easy, or providing them with mechanism by which they can tell when their practice approaches perfection.

Considerable ingenuity is displayed in several such patented games in the construction of a "pitcher" which (should one say "who?") delivers the little rubber ball at various speeds and angles.

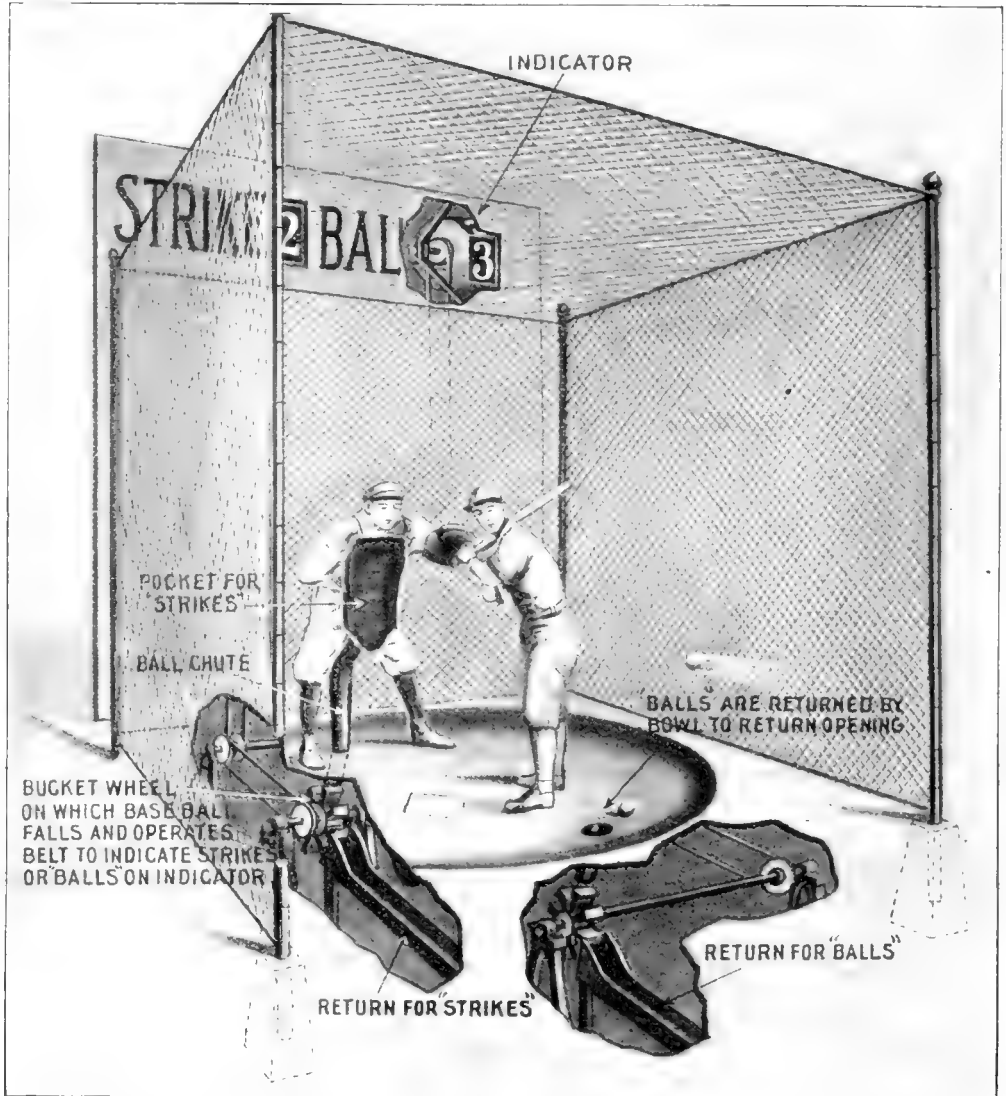

This apparatus for teaching the art of pitching a baseball provides for everything except derisive howls from the bleachers. Both the batter and the catcher are dummies. The catcher-dummy has a cavity for receiving pitched balls, the entrance to which corresponds with the area for a "strike." Above is an indicator for "strikes" and an indicator for "balls." When the pitcher throws a ball over the home plate at the right height, it enters the cavity in the dummy-catcher, drops down a chute and hits the blade of a bucket-wheel. Since the bucket-wheel is connected by belts with the indicator above, the pitcher sees his "strike" recorded. The ball is ultimately sent back to him by a return trough. If the pitcher fails to make a "strike," the ball drops into a bowl in which both the batter and catcher stand. The ball rolls into an opening and falls upon a bucket-wheel, connected by belts with a "ball" indicator. A special trough is provided for the return of the ball

But such games, no matter how ingenious and interesting to those who love baseball for itself, are tame sport for the active and are really only for the sedentary. Much larger and more intricate mechanisms are invented, pat-

ented, and operated at country fairs, where the spectator becomes an actual player and pitches against an automatic umpire.

The "automatic umpire" is usually some form of opening in a background.

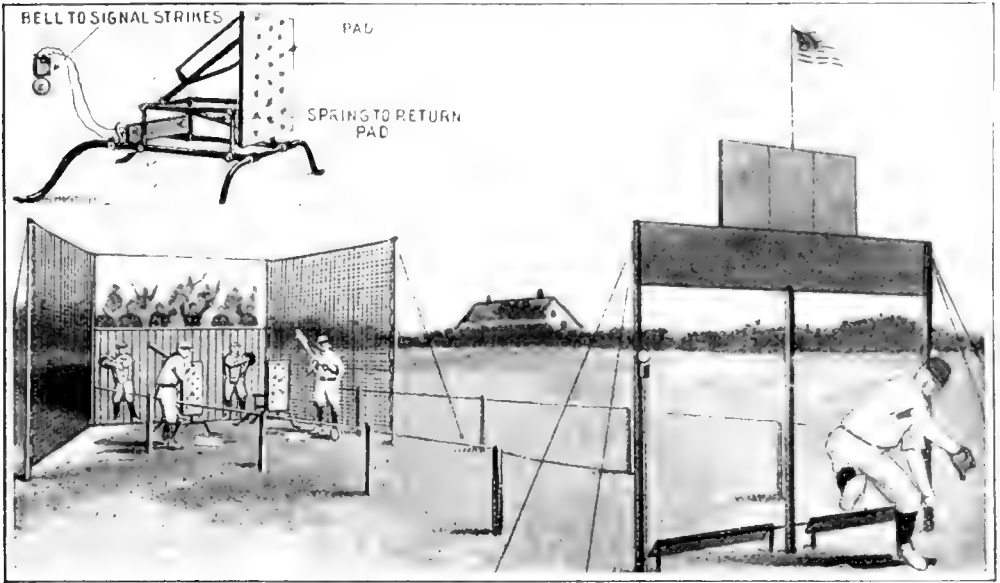

At the end of a lane formed by rope fences is a wall on which the figures of catchers are painted, as well as enthusiastic occupants of grandstand seats. Two home plates are provided—one for a dummy left-handed batter and the other for a dummy right-handed batter. Immediately behind each home plate is a pad, corresponding with the "strike" area. When the pitcher makes a "strike," the pad moves back, completes an electric circuit, and rings a bell. A spring returns the pad to position, whereupon the bell ceases its ringing and the apparatus is ready for the next pitched ball

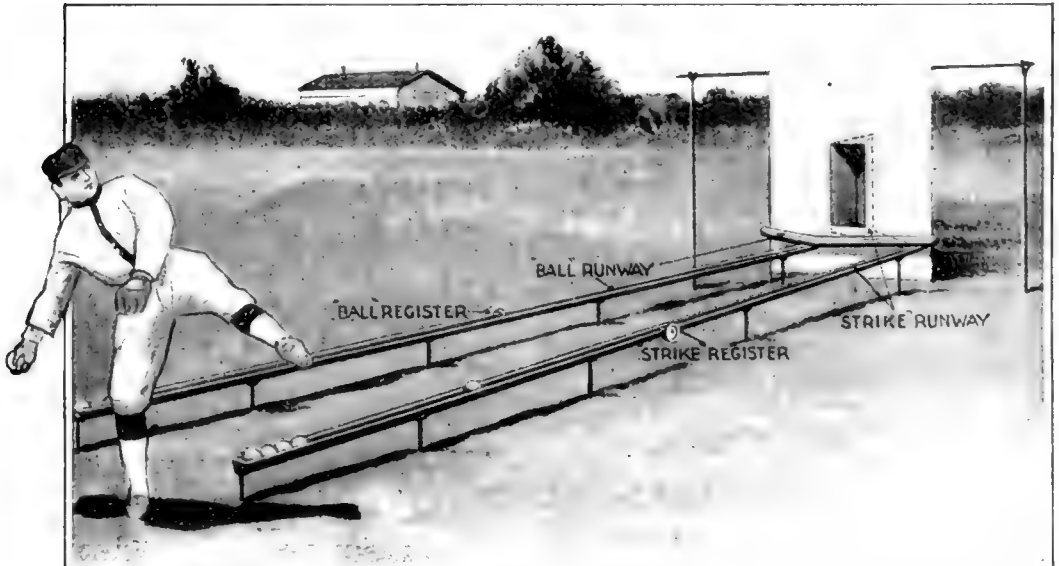

A sheet of canvas, stretched on a frame, has an opening the exact shape of the "strike" area to be considered by the pitcher. Back of the opening is a pocket communicating with a trough behind the sheet, leading to the "strike" runway shown. A second trough extends across the front of the sheet and communicates with the "ball" runway shown. Pitch a ball so that it passes into the opening in the canvas and you make a "strike," the ball being returned in its special runway after recording the "strike" on a register in the runway. Pitch a "ball," which means that you fail to land in the opening, and the ball will also be returned by way of the "ball" runway, your inaccuracy being subsequently registered by another recorder



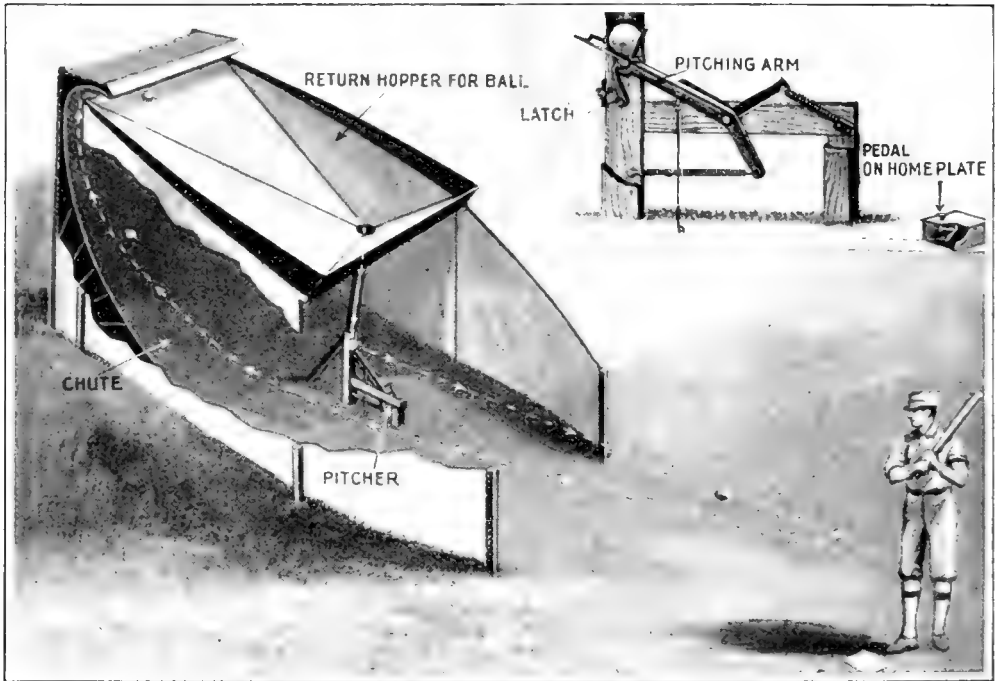

The mechanical batting instructor not only pitches the ball but returns it to the pitching-machine. You simply bat and bat and bat until your arms ache. The ball is sent up an inclined plane, which has a reverse curve at the top, so that the ball finds its way into a hopper and into a funnel leading to a pitching-machine. The insert shows how the pitching-machine works. The ball drops on the upper end of a pitching-arm. As it does so it releases a latch by which the pitching-arm is held against the tension of powerful springs. Suddenly freed, the pitching-arm hurls the ball at the waiting batter. On the home plate is a pedal connected with the pitching-arm. By pressing the pedal with his foot the batter can reset the pitching-arm as fast as he wishes.

As one inventor plans it, the chest-protector of the figure of a catcher in lifelike attitude is made as an opening of such size and shape as will accurately represent the plane in space, of which the width is that of the plate and the height the distance between knee and shoulder, through which, according to the rules, a pitched ball must pass in order to be a "strike."

Far more interesting, however, to the average visitor to a country fair is the type of device in which he takes bat in hand and stands in a batting cage, to try his skill with the ash against a mechanical pitcher which actually pitches real baseballs. He does this fearlessly enough; for it is the one great advantage of the pitching-machine that it is never "wild" and never, therefore, at all apt to "bean" the batter (hit him on the head). Some of these mechanical pitchers are but spring-guns designed to fire

baseballs at the batter. Others have a figure in front of the gun-barrel which raises its arm, goes through a "wind-up" and makes a throwing motion coincident with the actual delivery of the ball.

To still further extend the illusion and make of the practice of batting a "game," a "mechanical ball field" at a reasonable distance from the batter is sometimes provided. Here a numerous crop of targets appear in serried ranks and various heights. Any one of these targets, hit with a batted ball, registers in a convenient place the "value" of the batted ball. It may be a one, two or three-base hit, a "home run," "ground-er," "fly-ball" or what not.

Of the devices actually used by baseball players to train themselves in the art of playing the game, the pitching-machine would seem the most common. The "automatic umpire," however, seems to have some claims to real use.



# An Excavator Which Walks

A BIG excavating machine which literally walks to its job is being used by the United States Government on one of the great irrigation projects of the Southwest, and the advantages of this pedestrian accomplishment are many. Most of the machines of this character are built to roll over the ground on wheels, but its movements are necessarily limited, for it dare go only where the ground has been carefully prepared for it. Unless the path is most favorable, planks must be carried ahead and laid for it to move over. Otherwise the wheels would tear up the road and such a thing as making a short cut across the country would be out of the question, for it would soon be hopelessly stalled and its extrication only made possible by removing it piecemeal. In fact, this is the way in which these machines are generally transported from one job to another. They are taken apart and transported in convenient parts and reassembled at the

new point in the field of operations.

This perambulating excavator will "walk" along the road without any regard to the character of its structure and not leave a footprint behind; and furthermore, if the road does not happen to be the shortest route, the machine will walk across country over soft ground which will barely hold a man. If a house, tree, or hill happens to be in the way this machine will walk around it, covering the ground at the rate of twenty-five or thirty feet a minute, a very respectable speed for such a lumbering sprinter.

When the digger is at its regular work of excavating, it rests on a heavy central platform on which it is revolved so that activities of the bucket may be accurately controlled. When it is desired to have the machine move, the engine is connected with a driving-shaft extending across the width of the excavator. On each end of this, outside of the house of the operator, are

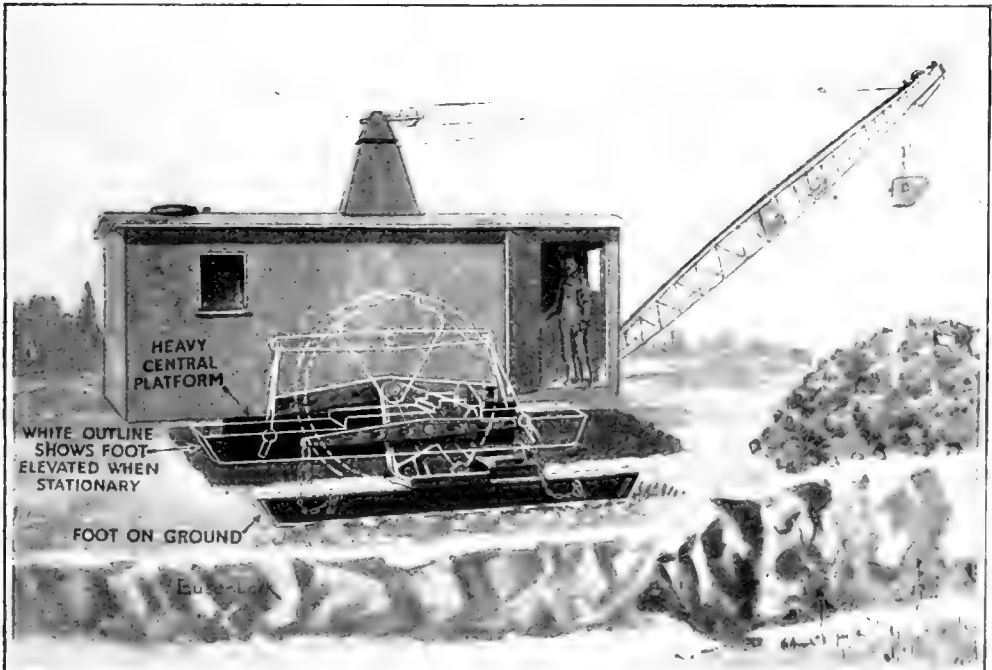

Two footlike pieces are suspended beneath the cams on either side of the driving-shaft. In moving, the feet are lifted and lowered alternately, producing a steady, deliberate walk. To change the course of the machine, it is turned when resting on the central revolving platform

mounted two large cams. Directly under each of these there is suspended a foot. As the shaft revolves, these feet are lifted by the chains which are suspended from a carrying beam attached to the cams and drawn forward and dropped on the ground, whereupon the cam comes in contact with them and its toothed surface engages with similar depressions on the foot. The whole machine is raised and moved forward and gently placed on the ground again, the motion suggesting nothing more than a deliberate walk. It is said that this additional apparatus represents no more weight than the skids, planks and other paraphernalia made use of in the movement of other excavating machines when shifting location.

In this manner the machine will follow a straight line. When it is necessary to change its course for any reason, the walking apparatus is stopped at a point when

the combined weight is resting on the revolving platform under the center of the machine. By making use of the latter the machine is headed in the desired direction, after which it will proceed along its new course as long as desired. When engaged in trench work, which is of a progressive character, the machine "walks" along as the work on the trench is completed. This is a great advantage in the reclamation service in which these machines are employed by the Government instead of mule teams, which have been eliminated by machinery.

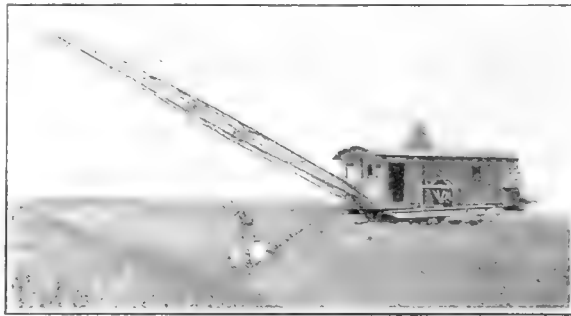

This excavator is being used with success by the United States Government on one of the great irrigation projects of the arid Southwest

The driving-shaft, the huge cams and the feet suspended by chains from the bars on the cams are shown in their relative positions in the picture appearing to the right

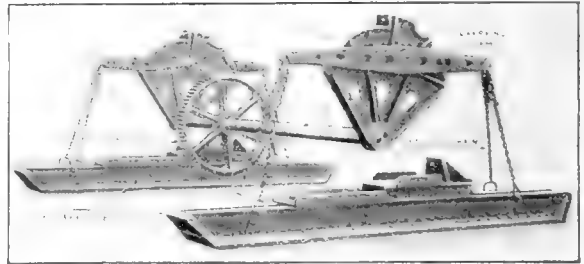

### Nations Bleed in Peace as Well as in War

CANADA is awakening to the fact that while she is bleeding openly in war she has been bleeding quite copiously in time of peace. In other words, a comparison of the industrial accidents and casualties with a list of the casualties of the Canadian Forces at the front, reveals the information that certain arts are as destructive, in proportion, as certain forms of warfare. Furthermore, Canada believes that she has opened her heart and administered with every effort to those crippled in the war, but has given little attention to those crippled in the arts of peace, except to pay them a small indemnity.

Despite the fact that improved ma-

chinery has been installed in most Canadian plants, cutting down appreciably accidents formerly due to old operating methods, the number of accidents has continued to keep up. For instance, Prof. F. H. Sexton of the University of Nova Scotia, at Halifax, has kept a careful record of killed or injured workmen in the industrial arts. Comparing his statistics for, say, December, 1914, with the same month for 1915, one finds that fifty-five men were killed as against fifty-six of the year before, while two hundred and sixty-eight were injured as against two hundred and seventeen of the previous year.

**Fighting Timber Fires**

**B**ATTLES against timber fires in the great national forests of the West are conducted with a degree of precision and strategy rivaling that of the warring armies of Europe, as the result of systematic operations of the United States Forest Service. A forest supervisor who may be many miles from the scene of a fire marshals his forces and fire-fighting facilities and directs the attacks and flank movements of his men.

Lookouts stationed on mountain peaks and other promontories that command a wide range of vision are each supplied with a plane table to which is attached a map of the surrounding country, its position being determined by means of a compass. The map is enclosed in a segmented circle and the location of the station is indicated by a pin. A

simple alidade (an alidade is the upper part of a surveyor's theodolite) consisting of a ruler with uprights for sighting purposes at either end, or some similar device, is included in the equipment.

When a lookout sees smoke issuing from a portion of the forest over which his station commands a view, he immediately sights it with his alidade and notes that it is coming from a point so many degrees east or west of a north and south line extending through his station. He notifies his supervisor by telephone, telling him of the apparent size of the fire and its location. Lookouts in

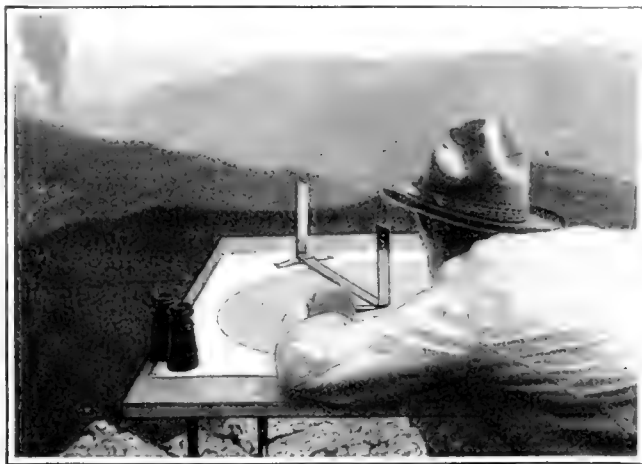

A timber fire in our western forests has about as much chance as a spy who is being watched

other sections of the forest also detect the fire and make similar reports to the supervisor's headquarters. Reports from two or more stations enable the supervisor to locate the fire on a map by means of intersecting lines.

**Conelike Flower-Holder in a Brick Wall**

**N**OWHERE is novelty more desirable than in the flower-holder line. This is what a resident of Los Angeles, California, thought when he constructed the novel fence flower-holder shown in the accompanying illustration. In this fence there are three sections, these being connected by six-foot "steps." In the center of each of these sections one of the flower-holders is located.



Flower-holder in a brick wall

Each of these containers is about three and a half feet in height and about a yard in diameter at the top. Each holder is in the form of a cone, being large at the top and becoming gradually smaller as it continues downward. While the fence within which it is located is made of pressed brick, the holder is made of brick of a clinker variety, being a trifle darker than the fence brick and harmonizing effectively with it in both color and design.

Maybe you have special needs. Write to the editor about anything within the scope of the magazine. He will be glad to help you.

The Official City Fly-Catcher of  
Redlands, California

WHEN A. E. Chapman, an inventor, offered his first patent fly-trap for sale in Redlands, California, he did not have the least idea that he was taking the first step in creating a new city office, the only one of the kind in the entire country.

With the invention of his new death-trap for flies came the new official position of city fly-catcher. Chapman, the inventor, was appointed at a salary of \$10 a week, the office being in existence nine months each year. Chapman began work by placing scores of traps at street intersections, around restaurants, and in the rear of livery-stables.

The bait placed in the traps was fresh canned fruit, syrup, sugared water, sprinkled

with cinnamon, watermelon, or fresh meats. The flies crowded into the cages—and to their deaths.

The carcasses of the flies are removed each morning by the official fly-catcher. He decided that he would estimate their number by enumerating them in units of liquid measure. During the first year between two hundred and forty and two hundred and forty-five gallons were gathered, on the basis of fifty thousand to seventy-five thousand carcasses to the gallon. Taking an average of sixty thousand to the gallon, between 14,400,000 and 14,700,000 were coaxed to their deaths in a year.

Mr. Chapman built a "jumbo" trap, which he had in a "Made in Redlands" day parade, inside of which are two small traps and a monster home-made fly.

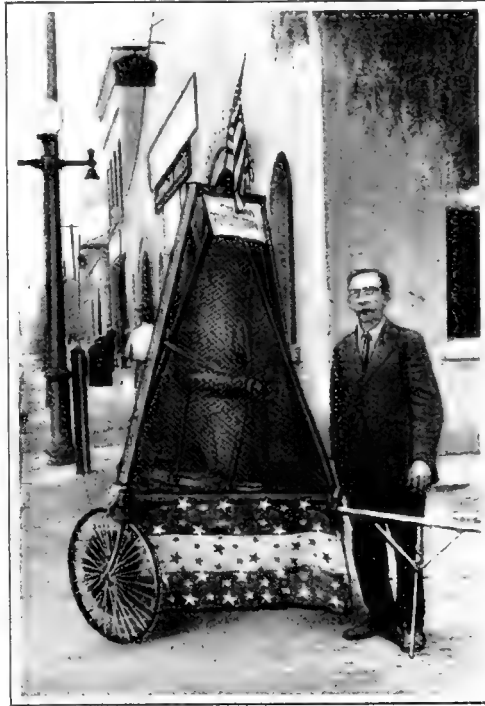

A professional fly-catcher who exterminates millions of flies each year

The Five-Wheeled Velocipede

A SMALL boy who was clever at designing mechanical novelties produced a five-wheel velocipede tandem from the parts of two machines.

One of the velocipedes met with an accident which put its front wheel out of use beyond repair. The other machine was sound, however, and the problem was how to construct a vehicle which would permit both the boys to ride.

The connection between the front fork of each machine was loosened, the bolts removed with a

monkey-wrench and the connection made again with the rear of each velocipede turned upside down. This made it necessary to remove the saddles, and they were placed on the rear forks close to the rear axle. Then the problem was how

to connect the two machines to form a tandem. It was accomplished by removing the rear axle of the leading machine and slipping it through the openings in the front fork of machine number two. The axle was then replaced and the wheels bolted on.



The loss of a velocipede's front wheel suggested this combination of two machines

# The Marvelous Voice Typewriter

Talk to It and It Writes

By Lloyd Darling

CONCEIVE an ordinary machine resembling the machines in common office use—full of the customary cog-wheels and crooked levers and variegated springs. It might be an adding machine so far as one can judge by external appearances or a dictaphone or a new-fangled cash register. But—

Speak to it!

It becomes alive. It *hears* you. It vibrates with action. Somewhere inside, typewriter bars go "clickety-click-click." At the top of the machine a sheet of paper unwinds from a roller.

*The machine has written down what you have spoken!*

If you said "cat" it wrote down "cat". If you said "Dear Sir: Your favor of recent date received and—," as though you were starting out an ordinary, time-worn business letter, it wrote that same thing down.

An odd feature about the machine is that it spells words as they sound and not according to some fat dictionary. Indeed it would have to be a phonetic speller. How else could it distinguish "dough" and "tough?" But if you are considerate, and mindful of its feelings enough to spell out words correctly in cases where it might be likely to err,

the machine will very obediently follow you and make the resultant letter strictly orthodox so far as spelling is concerned. It faithfully tries to do its best.

Does the machine think, as well as hear? How else can it perform all these feats if it doesn't reason?

Unfortunately, the machine doesn't think, however much it may appear to approach that desirable attribute. One reason is that at present the machine is brainless. But, even if it had a brain, that organ would be of no use in controlling parts completely separated. Thus far



The largest camera in the world, used by Mr. Flowers in experiments for recording rapid sound vibrations

the inventor of this contrivance, Mr. John B. Flowers of Brooklyn, N. Y., has succeeded only in getting the various parts to operate, alone and by themselves—in itself no mean achievement. The machine as we have depicted it is the conception toward which he is working. It opens up a wide vista for the imagination. Think what it means for the office of the future to have an almost human machine at hand to perform the routine drudgery of typewriting and letter-writing!

Unlike most projected inventions of the kind this machine was not conceived as an idle dream. It is based upon sound technical reasoning and researches as

# How the Voice Typewriter Works

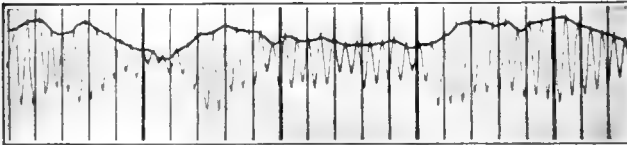
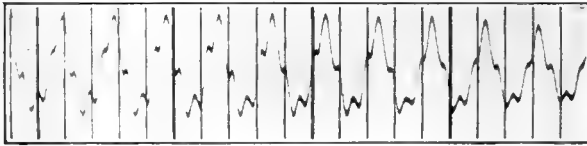
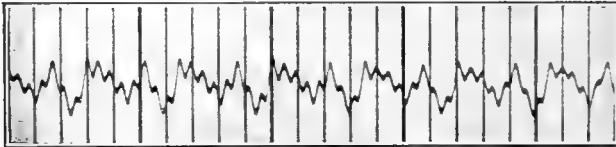
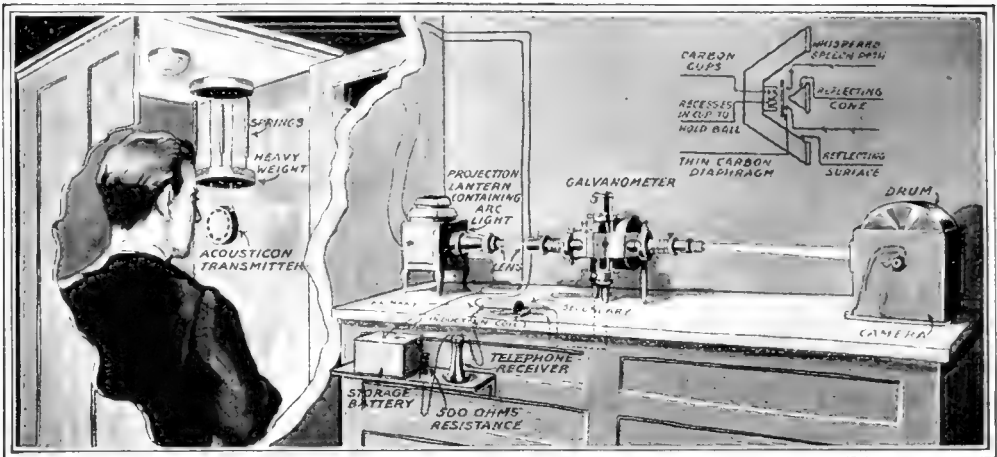

This is the machine used to evolve the natural alphabet. The man at the left is whispering into an acousticon or loud-speaking transmitter, which is attached to a heavy weight, in turn suspended by springs. The inertia of the weight and the resiliency of its spring supports, prevent exterior vibrations of any kind from jarring the extremely sensitive transmitter. Connected with its circuit is a string galvanometer. The whole arrangement is so sensitive that faint whispers readily cause the "string" to vibrate. Light from the arc light throws a shadow of this vibrating string on to the camera at right. A revolving drum carries a strip of photographic film and makes a permanent record of the vibrations. Sample records are given at left, together with an explanation below of what those particular curves signify.

These strange curves are records of the whispered and spoken vowel "U"

The strange curves shown above are records obtained from the apparatus. Upper Curve: Man's voice pronouncing the letter "U" bringing out in striking fashion the fact that any underlying curve is obscured by extra humps due to the peculiar nature of the particular speaker's voice. Middle Curve: Woman's voice pronouncing the same letter "U." Note differences from same letter pronounced by man's voice. Lowermost Curve is obtained when the letter "U" is whispered. Whispering is the most elemental way one can transmit speech, since it does not require use of the vocal cords. Contrast this curve with the two preceding. Note that instead of a series of repeating diagrams

peculiar to a particular speaker's voice, a definite undulation or wave-shape now appears. In the two upper curves this underlying wave-shape was blotted out by extra curves or humps known as "higher harmonics" which arose from the use of vocal cords and were different for different men's and women's voices. This underlying wave-shape was none the less present in the two upper curves, because a sound shaped in this precise manner is necessary before the brain recognizes the letter "U" as such. Mr. Flowers' feat consists in recognizing this principle, and in demonstrating it. He whispers the whole alphabet into the transmitter of the apparatus shown above, and secures ac-

curate photographs of the undulations, or "letter patterns" resulting. A complete set of these is shown on Page 68. Mr. Flowers found that it makes no difference who does the whispering; the same wave form for the same letter always results. Scientists recognize this as an immense step in advance, because heretofore men attempting to get at the real nature of speech have always been frustrated because the higher harmonics blurred out the true wave present. They could not deal with whispered speech because no apparatus sensitive enough to record whispered speech existed, and the curves they obtained with spoken speech varied hopelessly with each different speaker's voice.

# Experimenting with the Phonoscribe

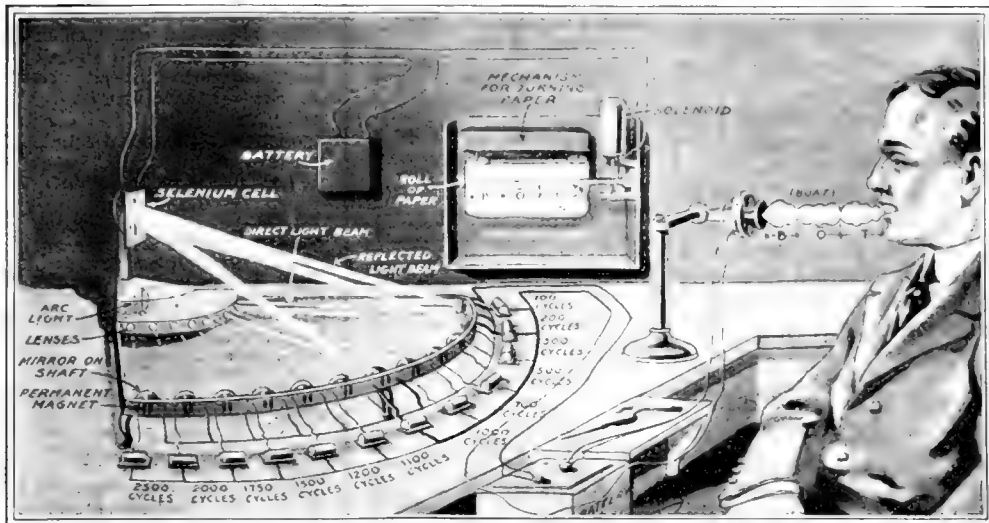

This machine is sometimes referred to as a "phonoscribe." It is designed to take dictation, writing words down on paper in natural characters as fast as spoken. It is of interest here as a forerunner of the voice-operated typewriter. The man at the right is pronouncing the word "boat" as an example. The "a" in boat, being silent, produces no effect on the machine, since it must necessarily spell words phonetically, or as they sound. The "bo" sound vibrations proceed into the transmitter and affect an electric circuit in which are 12 vibrating-mirror mechanisms. Detail of these is given in the figure below. Each mechanism is tuned by the small coils back of it so that it will only respond to vibrations, or cycles, of a certain magnitude. See page 70 for further description.

The black rectangles beneath the word "(Boat)" at right make clearer the workings of the selenium cell shown in the picture above. They may be

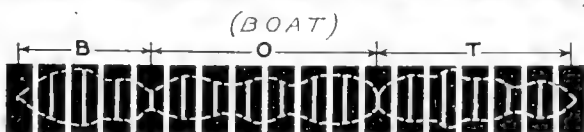

considered a series of instantaneous views of the selenium cell while the light beams are varying in length over its surface. The white strips in the center of each view show how much the light beams happened to be vibrating at each particular instant. The white curves connecting the bottoms and tops of these strips of course have no real existence but were drawn in to show how the light-beam lengths follow the original shape of the word "boat" as sketched in, in front of the man's face. Note also how the curve traced by the solenoid and pen varied directly with the length of these light-beams, tracing the identical curve.

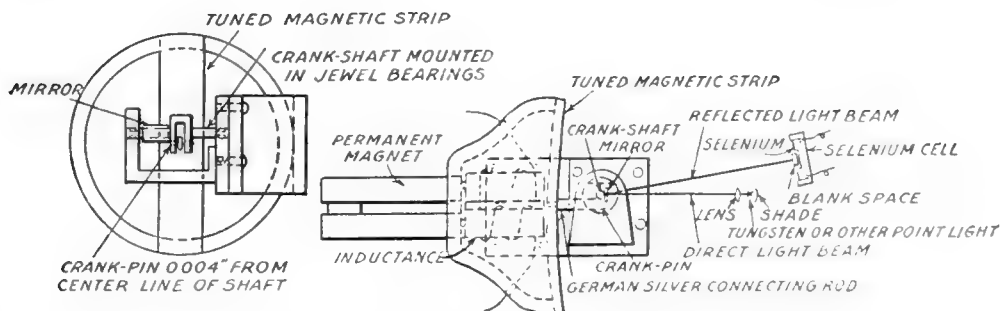

Detail of mirror-moving mechanism. Similar to a telephone receiver in general construction, the tuned magnetic strip taking the place of the usual diaphragm. Attached to the strip is a short lever working a tiny crank-shaft on which a little mirror

is mounted. Vibrations from the strip rotate the crank slightly causing the mirror to move through a small arc and throw its beam of light up and down on a selenium cell in the manner shown in the illustration at the top of the page.

well as on experimentation, back of which were the resources of a great type-writer company.

The line of reasoning involved in designing the machine, though somewhat intricate, is exceedingly interesting. Getting any machine at all to respond to such an uncertain and variable director as the human voice, is a task beset with difficulties.

### Speech Had First to Be Studied

In a recent paper which he read before the American Institute of Electrical Engineers, the inventor discussed researches lately completed into the true nature of speech, these having a great deal to do with the practical workings of the eventual machine. It was discovered that all speech can be represented by a sort of natural alphabet of sound patterns, which, no matter what the voice may be, always have the same shape. When a man, for instance, pronounces a given word he molds air waves in precisely the same way as does a woman. So far as sounds go, a Choctaw Indian is as well provided as a Harvard graduate; the only difference is that the sounds are grouped differently. This is a fundamental law. The mechanism of speech is the same in all of us. Heretofore physicists and workers with speech and sound have been troubled by the fact that they had nothing definite to work with. The consonant letters, when one person spoke them, would appear to have much the same wave shape as vowels enunciated by another speaker. In fact, even consonants and vowels produced by the same person sometimes seemed to have these indeterminate shapes when the scientists squinted at them through their sound-wave recording machines. Hence the task of ever getting spoken sounds analyzed and classified for study seemed hopeless. Until these letter-sounds were analyzed

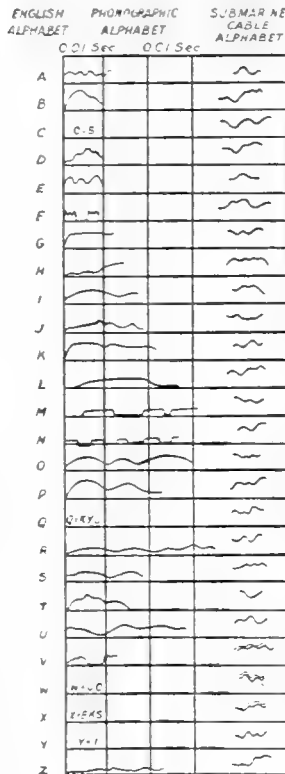

After all, what are spoken words but telegraph signals sent through the air, collected by the ear, and interpreted by your brain? Consider spoken words as sound signals and the voice-operated type-writer becomes possible

Alphabet of natural letter-patterns obtained with the apparatus shown at top of page 66. Note that the natural alphabet is not unlike that now used in submarine-cable telegraphy, though of course the two alphabets have no connection, theoretical or otherwise. The machine shown on page 67 spells out words in this natural alphabet.

This phonetic writing may some day be used in offices as a sort of shorthand system, the dictator talking into a machine similar in principle to that shown on page 67, and the stenographer afterward reading the wavy line from the roll of paper as easily as she would her own notes. The machine with its present design is entirely in laboratory form—interesting however, for the novelty of the idea on which it is based, and because it comes closest to tracing the true wave-form of speech of any machine yet devised.

and classified so that somebody could reason out the real underlying law they obeyed, it was obviously impossible to go far toward a voice-operated type-writer. One cannot simply say "Write!" to an inanimate collection of levers and expect them to respond.

### Why Whispers Were Studied

The instruments which were used in determining the real nature of speech sounds are shown on Page 66. With this apparatus Mr. Flowers dealt only in whispers. Why? Because whispering is the most elemental way one can convey speech. When you whisper you make no use of the vocal cords or other complicated mouth and throat mechanisms. It may be said in passing that one of the principal reasons previous workers with speech sounds failed to get at true sound-wave shapes was that over-tones (extra tones that cause a given voice to have its peculiar and distinctive nature) caused the shape of the main tone or fundamental to be obliterated. Resonant or echoing tones arising in the



# What the Word "Boat" Looks Like in Air Waves

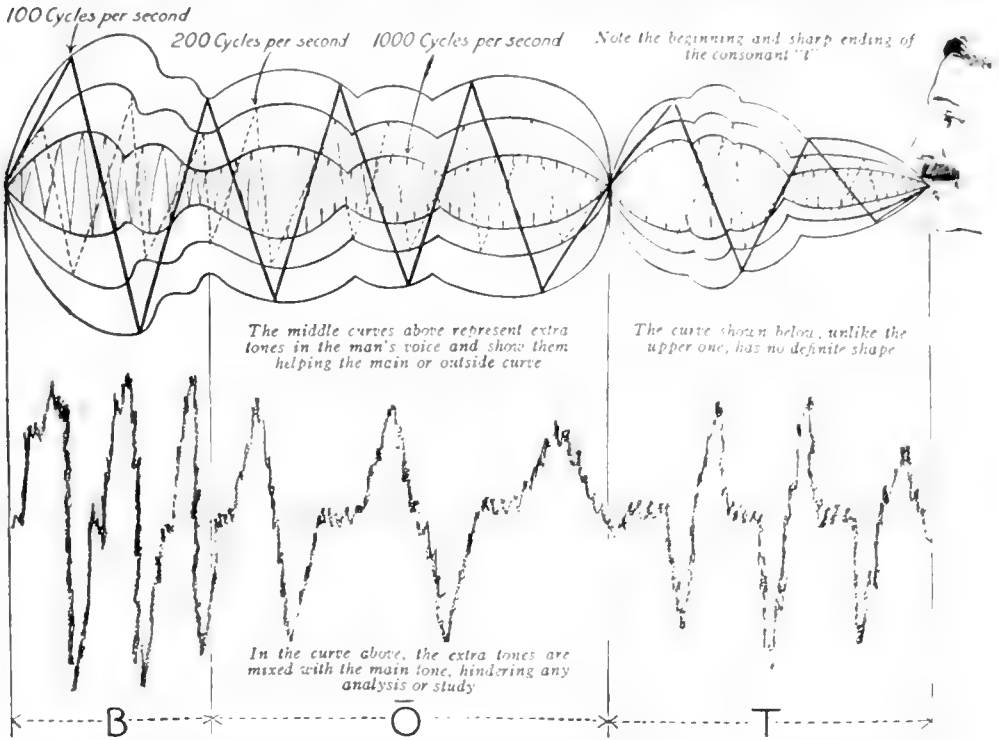

The protuberance from the man's mouth in the upper picture is not an unnatural excrecence. He is merely pronouncing the word "boat" and molding air waves in the manner shown

This shows detail of the word "boat" as pronounced by the man shown in the illustration at top of page 67. "Boat" spelled phonetically, or as it sounds, is of course "b-o-l." Hence the curves for "b," "o," and "l," are all that need concern us here and the "a" can be left out of consideration.

These curves look complicated but are really simple and demonstrate most interesting points. In fact, they show us how we really speak, how we really mold air waves in pronouncing a given word. The upper set of curves are in the natural alphabet, as can be verified by comparing their shape with "b," "o," and "l" as given on page 68. The lower curve is the kind the old-time physics teacher would throw on a darkened screen as representing sound vibrations for such a word as "boat." It does represent such sound vibrations but they are in the crude, or unanalyzed state. The upper drawing shows the real multitude of curves whose jarring together, or "fighting," one might call it, caused the lower curve to be jagged and full of humps as it is. Mr. Flowers is the first to evolve this method of making clear the real nature of speech. Note how the machine shown on page 67 actually traces "b-o-l" on paper in natural characters, which ordinarily exist as ephemeral sound waves in front of a speaker, and which are difficult to capture and study.

mouth also aided in this. By dealing with whispers, however, the inventor at once eliminated all complications arising from the use of vocal cords and accompanying resonant vibrations. He could actually determine how it was that one's lips, teeth and tongue shaped letter-sounds and words into air waves.

As the figures on Page 66 explain, his apparatus was so sensitive that all sorts of whispered sounds could be recorded. The lower figure shows three sample records secured with the machine. Hun-

dreds of others were obtained. It was found that each letter of the alphabet had a natural wave form of its own. This was the same no matter who the speaker was. In fact, it was found that these were the wave patterns, which, transmitted by the air, strike the ear and cause the brain to recognize a given letter as such. In other words, the letter patterns secured on photograph paper represented the actual wave shapes which everybody must use in conveying intelligence by means of

speech. It was the first time they had ever been caught and recorded. Man has been molding sound waves into speech with his mouth and lips along lines represented by these curves for thousands of years; but he didn't know he was doing it. The chart on page 68 gives a complete set of these wave patterns. Just how a man molds sound waves into patterns such as these is shown graphically on page 69, the word "boat" serving as an example. "Boat" was chosen because its various letters, as explained in the figure, make use in succession of the lips, tongue, and teeth—three of the principal agents in shaping sounds. It is, therefore, a representative example.

*Splitting Up a Spoken Word for  
the Voice Typewriter*

Having discovered that a set of natural letter-patterns exists, the next thing is to make use of them. Accordingly the machine shown on page 67 was designed, and has in part been made to operate. It has been named the "phonoscribe," and is intended to write down speech in natural letter-patterns automatically. As is described in the figure, it makes use of a selenium cell\* and a set of special vibrating-mirror mechanisms. These latter are each arranged or "tuned," to care for vibrations only of a certain magnitude. This is necessary, for this machine is intended to deal with spoken speech instead of whistles as did the recording machine shown on page 66. Since spoken speech, as has previously been outlined, is full of troublesome extra tones which obliterate true wave forms, it becomes imperative to have such tuned mechanisms as these to strain out the main or fundamental wave from its incumbrances. As shown in the figure on page 69 the main tone has a frequency, or vibration-rate, of 100 per second. The incumbrances have rates respectively of 200 and 1,000 vibrations per second. The three mirror-mechanisms which handle these rates are shown throwing their united light-beams on to the selenium cell, enlarging and diminishing the width of this light beam in unison,

\*Selenium is a metal the electrical conductivity of which varies directly with the amount of light falling on it at any given moment.

and so cause the cell correspondingly to vary the electric current through the solenoid and recording apparatus shown in the center of the figure. The width of the light beams at any one instant of course depends on how much the mirrors happen to be vibrating, and this in turn is controlled by the amount of current coming from the telephone transmitter at the right. The transmitter naturally shapes this electric current to correspond with the varying sound waves reaching its diaphragm from the speaker's lips. The whole apparatus therefore works in harmony, and a string of natural characters appears on the paper, recording whatever the speaker at the right has said—in this case the word "boat."

This phonoscribe is interesting mainly as a forerunner of the actual voice-operated typewriter itself. It embodies some principles, notably that of the selenium cell and accompanying vibrating-mirror mechanisms, which will be used in the ultimate speech-recording machine itself. But in this latter case of the typewriter, a whole collection of selenium cells will be necessary—one for each key on the machine.

The selenium cells are so distributed that only one letter of the alphabet can affect them. Down inside the voice-operated part of the machine these cells will be erected to receive waves coming from the vibrating mirrors when a person speaks. The selenium cells within the machine are arranged to correspond to the characters of the natural alphabet (see chart of these, page 68). If an ordinary rotating mirror be placed in the path of the light beams coming from the vibrating mirrors, it will automatically "spread out" these beams from the straight line (such as is shown on the selenium cell of the figure on page 67) to their natural wave shape (that shown on page 68)—this on the same principle that physics teachers of old used to "spread out" sound vibrations on a screen, using a revolving mirror. The "spread-out" vibrations are intended to fall each on its own selenium cell in the base of the machine, and because of this falling on the proper selenium cell, to affect the corresponding typewriter key.

# The Feminine Gender of Preparedness

At left, women seated at desks learning the routine of the field telegrapher's work. This was easy compared with retiring at nine-thirty o'clock and throwing out of camp a venter of bathtubs

Below, one of the exercises that formed a regular part of the day's work. Two weeks of this and the women soldiers were considered "fit"

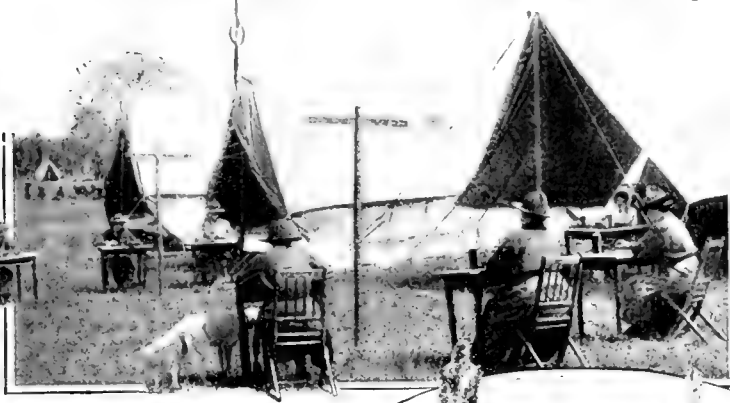

To demonstrate that getting ready for war is not a man's job alone, two hundred women from New York, New Jersey, Massachusetts and many other States have been camping since May first in quasi-military fashion at Chevy Chase, within sight of the dome of the Capitol. From reveille to taps, the latter at nine-thirty o'clock,

each day is crammed full of drills, setting up exercises, lectures, classes in care of the sick and wounded and Red Cross work. The soldierettes are routed out of bed at six-thirty in the morning, after a night on a hard cot, with only fifteen minutes to reach the mess tent for a breakfast of ham and eggs, boiled potatoes and prunes. There are no maids and no morning porcelain tubs. Instead there are galvanized water buckets and agateware wash-basins. The women members of the Navy League are the sponsors of the camp and the formal name given it is the National Service School



In the hospital tent shown above, the women were taught to make bed socks, operating robes and other hospital garments

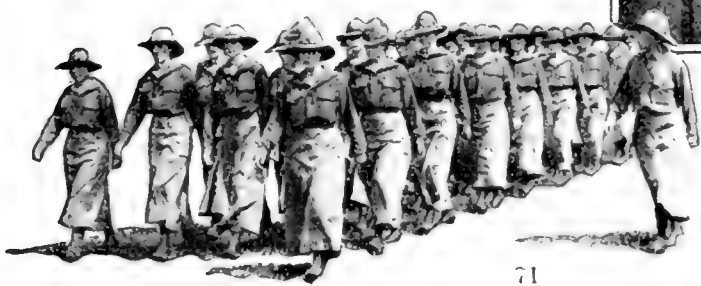

To the left, women marching in their long khaki skirts, army shirts, or rather waists, boots and broad-brimmed hats

# What Make of Car Is It?

By Prescott Lecky

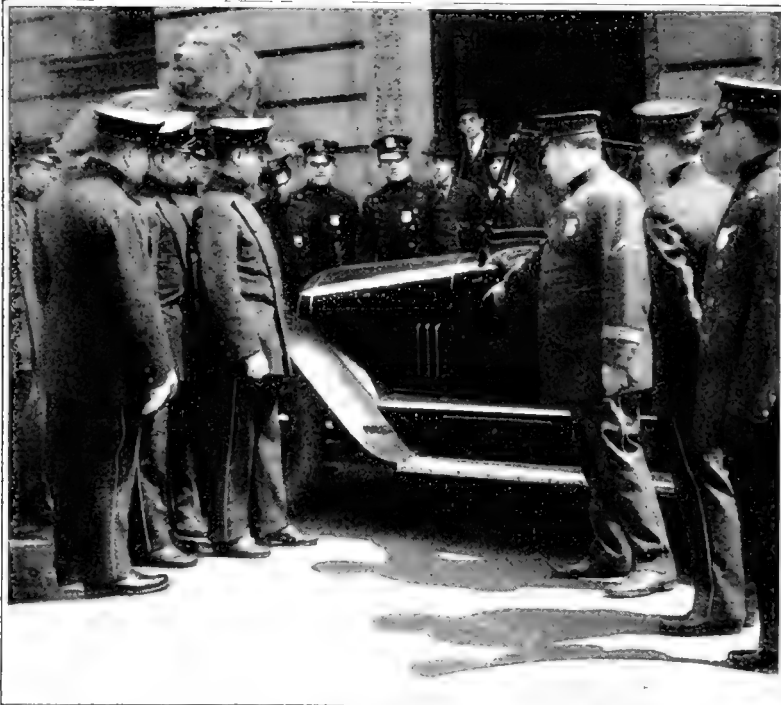

New York's police receiving instruction in automobile identification. Fifty-four different machines are thoroughly learned so that only a glance is needed to tell the make of car

Every visible part of an automobile is considered separately. To simplify matters, the car is likened to a human being, identification being from three angles—face, profile and rear as the charts on the picture below show

**H**AS your car a Roman nose, or is it pug? Do its ears stand out or lop over? Its eyes—-are they far apart or close together, deep-set, large, high or low?

This is by no means nonsense. It is the method of automobile identification now being taught the two hundred and fifty policemen who guard the outlets of New York city, such as ferries, bridges and main roads. The characteristics of

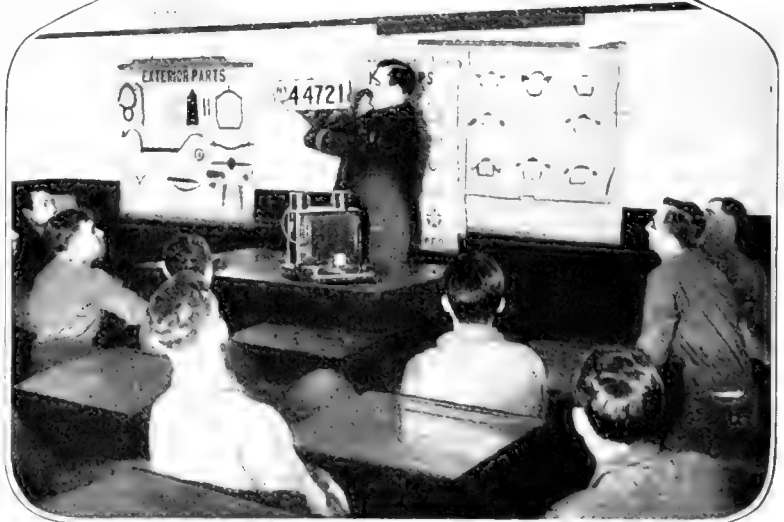

the different makes of cars have been compared and the individual features, or "factors of identification" carefully

sorted. Of two cars similar in other respects, for instance, one may have three oblique ventilators while the ventilators of the others are vertical. If no other car possessed a similar mark, it would constitute a factor. Such factors may be found on any part of the car: mudguards, headlights, radiators, hoods, gas tanks, tire carriers, springs and so on.

To simplify the system, the car is compared with a human being, and the patrolman is taught to identify it from three angles; face, profile and rear. Furthermore, since he recognizes each make by the factors, the trained patrolman makes a better identification for police purposes than would be possible for even the most experienced chauffeur, since he can swear to his evidence. He can cite the factors he observed as proof, whereas the chauffeur, though equally certain of his case, has nothing to support his decision as a rule except general facts. True enough in itself, nevertheless the cross-examining lawyer can make such evidence almost worthless.

In watching for a certain car in the traffic the patrolmen are taught to use the factors for rapid elimination, after Sherlock Holmes' famous precept of "observation, knowledge and deduction." If the car in question has a crown mudguard, for instance, one glimpse of a flat or oval mudguard is sufficient information. He drops the machine at once. Observing the remaining cars, or those with crown mudguards, he finds contradictory factors in all except the one he seeks.

All of the outlet posts of the city are connected with a single alarm system, and the descriptions of stolen cars, cars containing escaping criminals, or those wanted for any other reason, are communicated as soon as the crime is reported. The importance of training these outlet men to know the various makes is obvious. Eventually every man on the force will receive some instruction along these lines, and a short course has already been incorporated into the schedule of training for recruits.

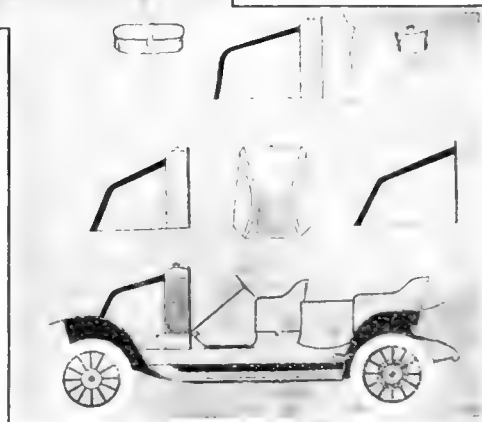
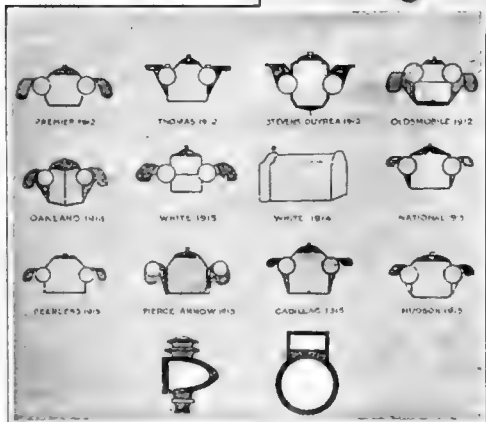
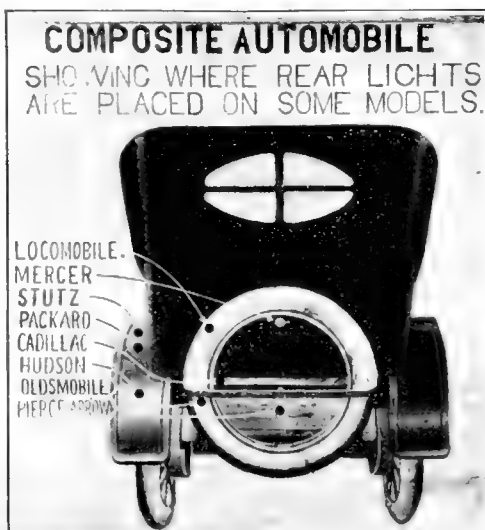

Note the face, eyes and ears of these cars and how they differ from one another

An escaping machine can be identified by the position of the tail-lights

The "nose" of an automobile is a good index to its lineage

# Preparedness Against Bank Burglars



The military force of a peaceful Chicago bank waiting for the lone burglar to appear. These men were put through a course of target-shooting to be prepared for holdup men who had been molesting the bank and its neighborhood for many weeks



**P**REPAREDNESS for war was not nearly so important and timely a subject with the bankers of Chicago recently as was preparedness for gunmen. For weeks there was an epidemic of holdups in the city. In the neighborhood of one bank, the Lincoln State Bank, masked bandits swarmed at all hours of the day, victimizing no less than fifteen patrons of the bank in a single week. With the police seemingly helpless to cope with the situation, the bank took steps to protect itself and its depositors.

The entire clerical force was mobilized in the basement of the building one morning and the first lesson in a course on how to shoot bandits on sight was given. Each man was supplied with a

revolver, a pistol range was erected, and target-practice was held. After the men were told to keep their eyes open when they shot and point the gun at the target instead of at themselves, they displayed marked proficiency with their firearms.

After a week of practice there wasn't a bandit intrepid enough in all Chicago to venture a visit to the bank. Indeed, the preparedness campaign became such a success that the holdup men forgot all about the bank and the surrounding neighborhood and migrated to other parts. In time the clerks became such crack shots and such confirmed militarists that they almost regretted the fact that they didn't have an opportunity to substitute a gunman's heart for the much maligned bull's eye.

All the specialized knowledge and information of the editorial staff of the Popular Science Monthly is at your disposal. Write to the editor if you think he can help you.

# What's Wrong with Big Aeroplanes

By Carl Dienstbach

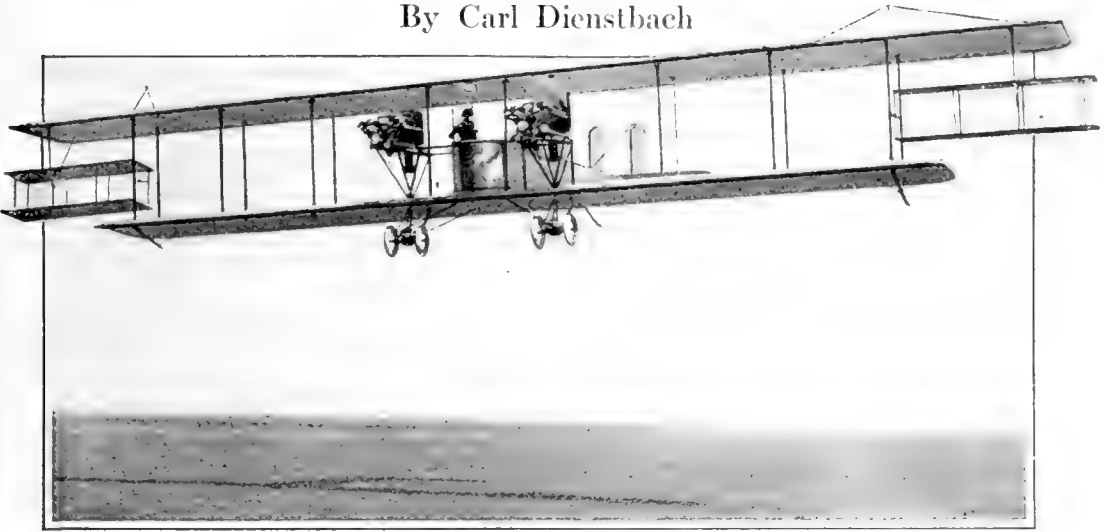

A novel feature of the first huge American land aeroplane is the use of biplanes for ailerons. This furnishes stronger control, at the expense of great head resistance.

WHEN Curtiss built the "America" for an intended flight across the Atlantic, he was compelled to design a big machine. The radius of action could be extended only by providing for much fuel. Fuel became the most important freight of the bigger machine. Increase of size will not in itself materially increase the radius of action.

For the reason given, the size of the "Americas" and "Super-Americas" is not only such that the radius of action is practically extended across the Atlantic, but a somewhat greater load can be carried. The Allies' lack of fast dirigibles made them eager bidders for the "Americas." But the difficulties encountered in increasing the aeroplane's size must not be lightly dismissed. Accidents now teach their lessons quickly. The first, a very dramatic one, happened in this country when on May 11 last, a "Super-America" for passenger service between Washington and Newport News suddenly turned over into the Potomac, after performing some somersaults, wrecking itself, killing two and injuring three passengers. Similar accidents had occurred in Europe, but they were hushed up for military reasons. So rigid and

strong was the large machine that axes could not break through in the effort to get at the victims below the floating wreckage. Yet, a big machine is weaker for its weight than a smaller machine. Very large sailing vessels must be square-rigged, and many small sails must be employed. Aeroplane dreadnoughts ought to be multiplanes on the same principle. This becomes imperative if the fact is considered that aeroplanes were for many years nothing better than death-traps, ready to break in midair and that it was exceedingly difficult to strengthen even the smaller types without making them too heavy. Landing on hard ground is particularly difficult. It means literally a collision with the earth. Huge flying boats are better off, their landing places are abundant and always level and wondrously soft.

But, after the recent accident one feels like asking: Isn't the "America" a somewhat mistaken construction? May success be expected merely by enlarging a successful small model?

A mammoth steamer may get along with proportionately the same size of rudder as a smaller one because it matters little if it takes it many times longer to complete a turn. But in



balancing an aeroplane, there is no time to lose. The huge machine is treacherous because its great inertia makes it apparently stable. But once it yields a little, it tries obstinately to yield more. The necessarily wide distribution of weights around the center of gravity aggravates this inherent tendency. In the light of these considerations the idea of using biplane-aileron on the first huge land aeroplane recently tried in this country seems interesting, a frank confession that stronger controls are needed, although an excess of head resistance at the wing tips, and objectionable leverage are the price paid for this improvement. The frame that holds the wheels has been strengthened by shortening it, which is made possible by raising the propellers and motors (to clear the ground) although the total length of framing remains the same. There is an advantage in having the lower plane thus laterally brace the length at the point it does. Otherwise the wheels themselves appear weak for a total weight of over two tons and the mass of open framework supporting the motors has undue head resistance; it has the excuse that the motors may thus be brought further ahead to increase the leverage and stabilizing effect of the tail.

The weak elevator contrasts strangely with the powerful ailerons and the double vertical rudder.

To find out what really happened to the wrecked "Super-America," we must read the testimony of the tugboat captain who happened to see the accident at close range. The flyers were given no time for observations. Eye-witnesses tell of a propeller working loose and an "explosion" that scattered small fragments before the plunge came. The mere loss of a propeller and the racing of an engine should not jeopardize stability. Probably the pilot, bewildered by the injury to the power plant and handicapped by relatively weak controls, failed to counteract some air disturbance.

The machine also was only one hundred feet up, too close to the water for righting a small monoplane, let alone a dreadnought. The "somersaults" before reaching the water testify to an "America's" lack of stability resulting from lack of leverage between the stabilizing planes and the principal weights which are not concentrated enough and not large enough in proportion to the amount of momentum. All long-hulled flying-boats suffer from such a lack of leverage, with no practical solution in sight.

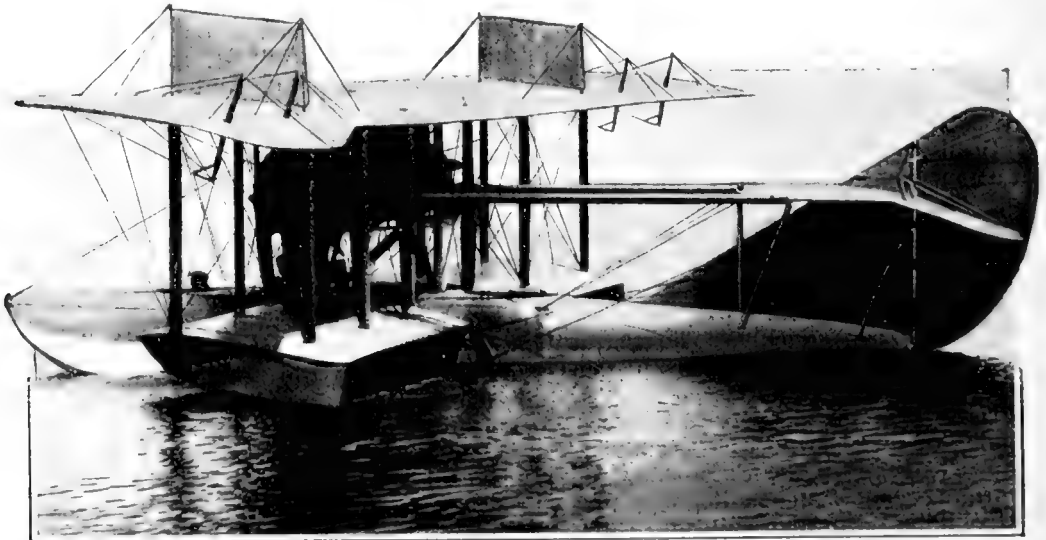

On a recent trip from Washington to Newport News this "Super-America" fell, killing two passengers and injuring three. So rigid was its structure that axes could not break through in the effort to extricate the victims



# As Easily Handled as a Rifle

## A Revolutionary Motion Picture Camera

By Charles  
W. Person

The camera opened to reveal the interior arrangement. The film box for the storage of the negative is shown at the left and the film leads from it to the exposing or camera mechanism opposite. To operate the camera the two parts are locked together to form a compact unit

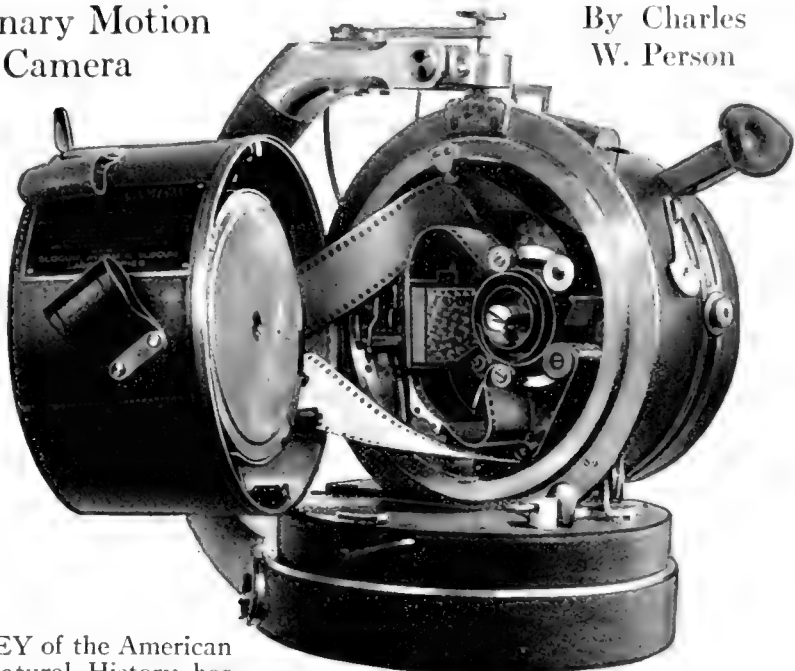

CARL E. AKELEY of the American Museum of Natural History has evolved a motion-picture camera so novel in its constructional and operating features that it gives promise of revolutionizing at least one of the diversified fields of motion-picture photography—that of the naturalist and big game hunter. It is the first motion-picture camera equipped with the necessary mechanism to enable it to enter the hitherto unexplored realm of the hand or still camera and thus place within the scope of the operator all the vast possibilities of quick action and instantaneous photography.

It is only natural that Mr. Akeley should accomplish something permanently valuable in motion-picture photography, since his wide experience as explorer and inventor has enabled him to discover at first hand the many limits and inherent deficiencies of the modern apparatus. As an inventor he is identified with the cement-gun and with many accessories to the hunter's craft, but he is perhaps best known as the man who has elevated taxidermy from the upholstery trade into an art. Many animals which form the most valuable

exhibits in our museums he has hunted and killed in their native haunts, sculpturing their bodies in clay before he covers them with their own skins.

As a hunter of big game in the wilds of Africa he has used the ordinary motion-picture camera, to find it deficient and even useless. He has attempted time and time again, and at risk of great personal danger, to photograph a herd of charging elephants, or an alligator stealing on its prey, or a trapped lion in its death throes, only to be disappointed in the finished film. He once had the rare opportunity to photograph a real battle between giant ants of the tropics, but before he could adjust the intricate mechanism of the camera and set it up it was too late. It was disappointments like these that stimulated him to concentrate his technical knowledge on plans for a new camera.

There are parts of the Akeley camera which have yet to be named—they are so new. Indeed, the instrument is such a radical departure from the newest of the old-style machines, that it has few features in common with them. Primar-

ily it was constructed to enable the operator, under all conditions, to take a picture in a minimum of time. To be exact, it can be mounted and trained on an object in thirty seconds, which is a feat impossible with the old-style apparatus. Furthermore, it can be rotated either in a horizontal or a vertical position, and it can take panoramic pictures at any rate of speed desired. These are only two of many important features which show the versatility of the machine.

The ordinary motion-picture camera is limited in operation to an angle of forty-five degrees above or below the horizontal. It must be used on a tripod, carefully leveled. In taking pano-

ramic pictures, two cranks, one for the horizontal movement, and the other for the perpendicular movement, must be turned simultaneously, either forward or backward, according to the direction of the swing required. Moreover, the panoramic action is confined to rectangular movements.

Other restrictions are the awkward lens adjustments; the friction of the film, which causes static electricity; excessive noise, making the machine impracticable for nature and wild animal photography; its bulkiness and weight; the long time required to assemble it and prepare it for operation; the lack of climate-resisting qualities; the numerous loose parts and accessories, and other handicaps too numerous to mention here.

The camera invented by Mr. Akeley overcomes these imperfections with a mechanism entirely new. In form his camera is cylindrical. It rotates in a steel ring on ball-bearings and is supported by a curved arm, which rises from a sub-base on which the panoramic-base rests when in operation. The complete apparatus, camera and panoramic devices, form a single compact unit to be used with or without a tripod.

By merely pressing the lever at the top of the

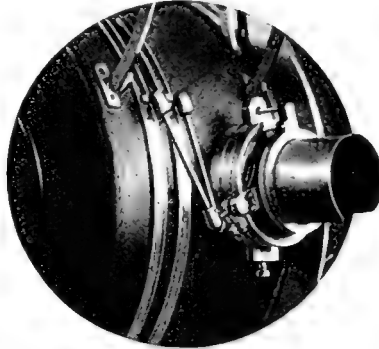

The lens and diaphragm mechanism which is automatically operated from the rear

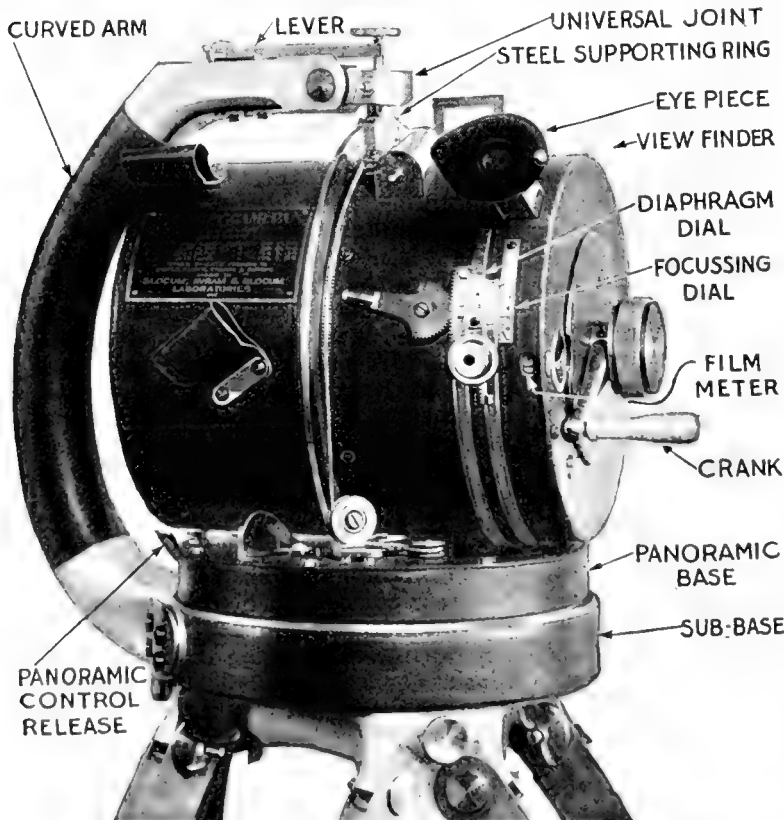

By guiding pressure of the left hand the instrument moves on its sub-base and is trained in any direction at the will of the operator

# Details of a Remarkable Motion-Picture Camera

## The Film Cutter

Five features distinguish Carl Akeley's camera from all existing apparatus. The film cutter shown at the right is used to cut a hole in the film to indicate to the developer when a given series has come to an end. The hole is also used as an aperture through which the operator can stop the machine, puncture the film, and then focus to a dead accuracy on a ground glass. Consequently, when the film is developed the perforation notifies the operator exactly where the stop was made. The cutter is actuated by a pull and push rod leading to the outside of the camera. One push of the rod cuts a hole in the film and brings the ground glass into position. An eye-piece attached to the film cutter enables the operator to locate the image on the ground glass and regulate the focussing and diaphragm dials

## Carl Akeley's Wonderful Invention

PULL AND PUSH ROD LEADING TO OUTSIDE OF CAMERA

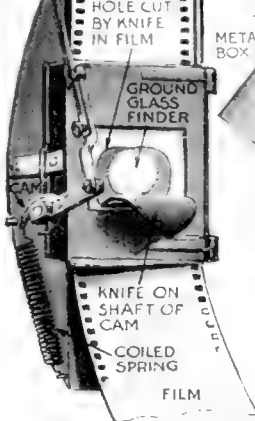

THE FILM CUTTER AND GROUND GLASS PLATE

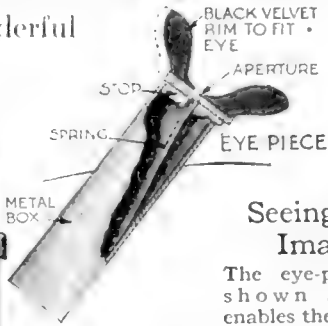

## Seeing the Image

The eye-piece, as shown above, enables the photographer to see the actual image being recorded on the negative—something hitherto unheard of. It consists of a square metal box with a sliding end fitted with a light-proof, black velvet rim for the eye. A spring which serves to lift the eye-piece up and which closes the finding aperture by a metal stop at the same time, is pressed down when the eye rests against the rim. This gives the photographer an unobstructed view of the image falling on the negative

## Getting Rid of the Flicker

The finger mechanism illustrated below controls the speed and feed of the film. As the main shaft revolves the eccentric bearing operates the finger, which passes through a slot in the film guide and engages the perforations of the film. As the main shaft turns, the finger is inserted in the film

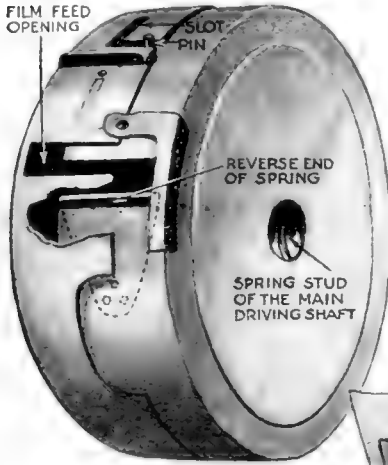

FILM BOX

## Eliminating Friction of the Film

The film box, as shown above, consists of two telescoping shells which are locked together by a pin and slot device. The inner shell has a spring with a roller end over which the film feeds out. This roller end serves to eliminate friction and also prevents scratching while taking pictures. The spring stud of the main driving shaft locks the film box with the driving gears, which in turn rotate the film at the speed set by the operator

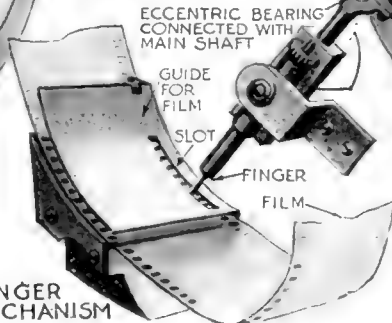

FINGER MECHANISM

perforations and withdrawn from them one by one so that the film is literally picked along. This gives a uniform movement and entirely eliminates all "jerkiness"

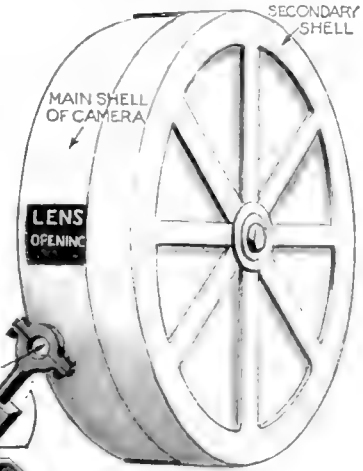

SHUTTER 1/2 CIRCUMFERENCE OF CAMERA

## How the Shutter Works

The shutter, illustrated above, consists of the main or outer shell of the camera containing the lens opening and a secondary shell half cut away, this latter being the shutter proper. As the secondary shell revolves over the main shell the lens opening is alternately closed and shut by that portion of the secondary shutter which has not been cut away. The exposure efficiency is increased to eighty-five per cent



Above, focussing straight down. As shown at the right, each foot-member of the tripod is attached to a sleeve, the inner end of which is a swinging cam bearing upon a spring attached to the tripod leg. The spring has a felt pad which locks the tripod members together by friction, the lever system (shown closed and open) being used

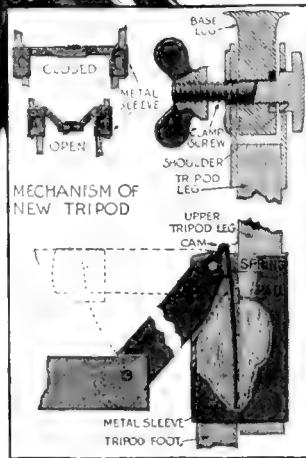

supporting arm the camera automatically levels itself and upon releasing the lever remains rigidly in that position. Without requiring any previous adjustment or setting, as is the case with the cameras generally used, it can be quickly adapted to any kind of panoramic view to be taken. A horizontal panoramic adjustment may be readily changed to a vertical adjustment and vice versa, while by manipulating the finger-piece the direction of rotation and the speed at which such rotation takes place may be adapted to prevailing conditions in a quick and reliable manner.

The camera can be mounted in the twinkling of an eye for rapid picture-taking. It can be trained in any direction as accurately and as quickly as a cowboy can draw a gun. If a tripod is not at hand a window-sill, a rock, a saddle-horn, a tree-branch, a knee—in fact, anything stationary may serve as a base for operations.

Where quick action is absolutely imperative, the newspaper photographer can film every stage of an exciting fire rescue, or a riot, or a sinking ship, or an explosion, or a shooting, or, indeed, anything heretofore solely within the compass of the hand or still camera.

The lens adjustments, instead of being in front, are in the rear, so that focussing through a diaphragm according to light conditions may be carried on while the picture is being taken. By means of an ingenious eye-piece the actual image on the film may be observed during the process of exposure. To appreciate the importance of this, it may be said that it never has been accomplished before in either still or motion cameras. The eye-piece remains closed until the eye is pressed against a light-proof, black velvet rim; the actual image being recorded on the negative is seen.

It is impossible to turn the camera so rapidly in any direction that a blur is produced. The range of tilting and "panoraming" permits the operator to turn his lens straight up or straight down beneath the camera itself. This enables the operator to photograph an ant hill or nest one moment and a Zeppelin the next. All friction danger is eliminated so that the film can not be scratched while taking pictures. The camera complete weighs thirty pounds; the old-style apparatus weighs from fifty to seventy-five pounds.

The film-containing box has very little in common with the boxes now used. The camera may be run at the standard speed of sixteen pictures a second, or the speed may be doubled or trebled, as desired.

The Finger Talk of Chicago's  
Wheat-Pit

THE Chicago Board of Trade is by far the most important grain exchange, not only of this country, but of the world, and few people are familiar with its method of operation.

People who visit the Board of Trade are perhaps most impressed by the sign language used in buying and selling

information necessary to consummate a deal, involving perhaps thousands of dollars, is conveyed by a few motions of the hand.

Each finger extended represents one-eighth of a cent. Thus when all four fingers and the thumb are extended, all being spread out from one another, it means five-eighths. When the four fingers and thumb are extended, but are



Where voices are smothered in the din, and where seconds may mean fortunes made or lost, traders resort to an effective sign language to buy and sell grain

grain for future delivery. Unlike anything else seen in any other line of business this wonderful system, while simple in its execution, nevertheless puzzles the uninitiated. It is a system that has grown up with the Board, and traders would be helpless without it. In that awful din where hundreds of men and boys are rushing about and shouting and countless telegraph instruments are clicking, individual voices are smothered and the trader must talk with his hands.

He has no time to waste—a lost second may mean hundreds of dollars to him. By a simple movement of his fingers the trader makes it known whether he would buy or sell, what price he is willing to pay or take and what quantity he wishes to trade in. All the

pressed close together, it represents three-quarters. The clenched hand with the thumb alone extended is seven-eighths, while for an even cent the closed fist is used. The thumb protruding between the index and big finger is the signal for a split quotation. Nothing less than 10,000 bushels can be traded in on a split quotation, which if  $90\frac{5}{8}-\frac{3}{4}$ , means that half is taken at  $90\frac{5}{8}$  cents and half at  $90\frac{3}{4}$  cents. These characters refer to the price, and the hands and fingers are held in a horizontal position. When displayed vertically the quantity is indicated, each extended finger representing 5,000 bushels. When the desire is to sell, the palm of the hand is held outward, and when the trader wishes to buy he signals with the palm facing him.

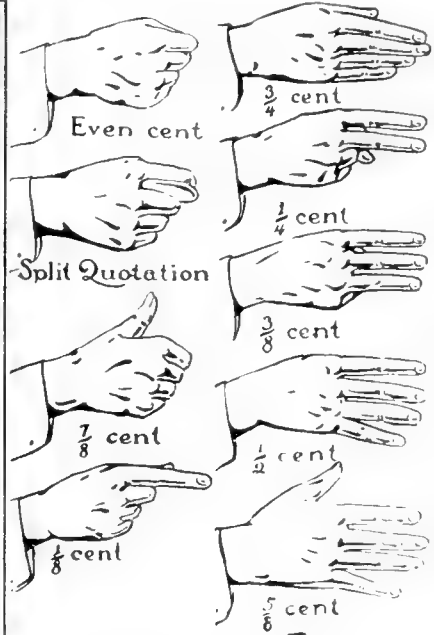

### Experimenting with the Siphon

A SIMPLY-constructed siphon offers a most fertile field for amateur experimentation. In some cases water can be made to flow straight up twenty feet into the air until it passes the curve in

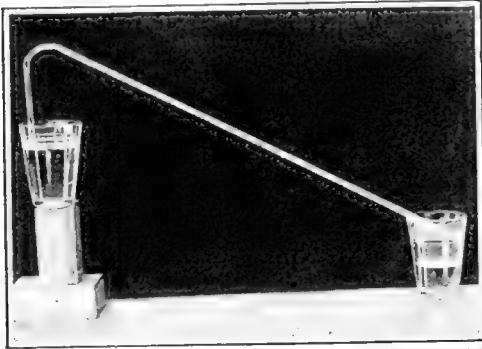

Two tumblers, one higher than the other, joined by glass tubing, can be used to demonstrate the siphon principle

The water will easily flow to a height of six feet with the apparatus shown at the right

the siphon and flows down again.

To carry on a series of experiments all the apparatus needed is a piece of glass-tubing and a connected piece of rubber-tubing. The glass tube may be bent in an alcohol flame, and a siphon so constructed that it will take water upward for six feet or more, and then downward in the other arm. If the joints are made tight the water will flow even higher. When the water has passed from one vessel into the other, the lower vessel may be raised, and back the water will flow, thus running uphill and downhill. The only difficulty in this experiment, aside from making the joints tight, is to fill the pipe at the start. This may be done by filling the entire pipe when the parts are all on the same level. The ends may then be stopped and the one end raised into a perpendicular position.

But with all siphons of this kind the trouble is to establish a permanent conduit between the two receptacles, since the siphon will exhaust itself unless the

higher vessel is always kept filled. A siphon will not wait for a fresh supply of water, but will empty itself and cease to act.

Recently one experimenter was obliged to devise a means whereby the siphon would hold its contents and wait for a fresh supply. This was accomplished by turning up one or both ends of the siphon. By this method a series of aquaria was connected so that water would run through the tubing and wait for a supply; that is, a tiny stream would keep the supply to the siphon running continuously, and the siphon would hold the water running at a permanent height.

Theoretically it is the push and not the pull that causes the water to run. The pressure of the air on the surface of

the water in the upper vessel pushes the water up to take the place of what would be a vacuum. The action is similar to the pull on the part of two pulleys, in which one is heavier than the other. It is evident that the heavier weight pulls up the lighter. So it is with the siphon. The curved angle of the siphon takes the place of the pulley, and the long arm full of water takes the place of the heavier weight. Once the long arm full of water starts it "pulls" the contents of the shorter arm.

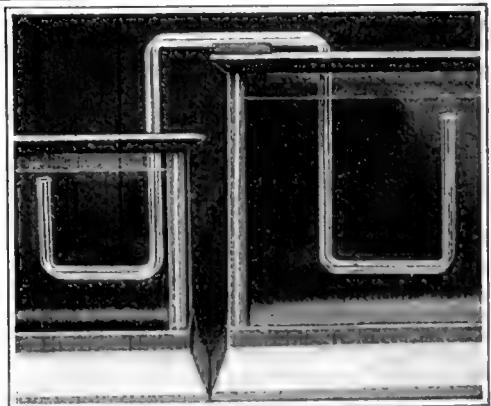

How the glass tubing is arranged when two large jars of water are to be siphoned. The test may be carried on indefinitely by reversing the position of the tubes

Forty Miles an Hour on the Water

A BOAT has been designed by D. N. Brown, of Grand Haven, Mich., which, on test runs, has attained a speed of forty miles an hour. The body of the craft is made of thin galvanized iron over a basswood framework two feet wide and twenty feet long. Two galvanized iron air-tanks are attached to an outrigger five feet from the rear end on both sides. When the four-cylinder motor, set in the rear, whirls a six-inch propeller, the prow rises out of the water and the craft skims along like a huge bird over the surface, the entire weight resting on about three feet of the stern. The two tanks maintain the equilibrium.

The boat has proved a success in all ways and the inventor believes, with an improved design, that he will have a craft capable of making sixty miles an hour without being crowded.

It is evident that the inventor reduces skin friction as much as he can, for which reason he is able to travel at high speed in his boat.



Forty miles an hour is the claim of the inventor of this craft, which partially rises out of the water when it is under full speed

of this rakish craft. Lie down comfortably upon the keel of the ship (which should be so laid as not to interfere unduly with any of your spinal peculiarities), grasp the conical rudder-control with both hands, set your gaze intently upon your goal and pedal for dear life.

The rudder is a ball and socket affair that will steer the ship in any direction in the water. The pedal-propeller-gearing is at a two to one ratio to insure speed, and the pontoons *A A*, are inflated to the required buoyancy; *i. e.*, to float about one-third out of the water.

With a score of these one-man scouts darting across the water a battleship's squadron might anchor in perfect security and laugh at the deadly submarine. Or they might be hitched tandem, so that you may invite your fair lady to take the air on the ocean and save not only the carfare to the nearest beach, but bath-house hire as well.

What Ho! The Jitney Yacht

THAT every man who runs may cruise the seven seas, a jitney

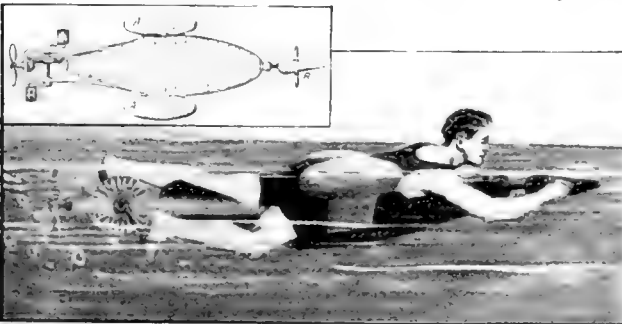

The timid swimmer can now go through all the motions of swimming while being supported by a concealed water-bicycle

New York is the World's Luxury Market

LONDON, the world's central market for the sale of luxuries of every description, has been practically closed and New York has taken its place. Custom House records show that the imports of the "luxury class" have increased enormously, particularly in the items of precious stones and works

yacht has been evolved. It is indeed a peace ship—a one-piece—one man, semi-submersible. A glance at the anatomical chart appended, will explain the action

of art. As a single example, the American automobile industry's imports of crude rubber in the past year amounted to more than \$111,000,000.



# What Can Be Done with a Ford Chassis

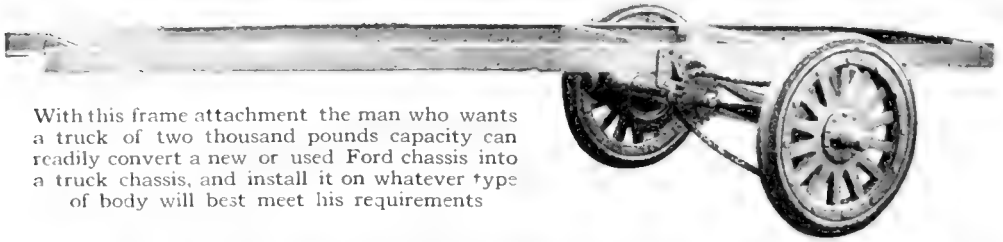

With this frame attachment the man who wants a truck of two thousand pounds capacity can readily convert a new or used Ford chassis into a truck chassis, and install it on whatever type of body will best meet his requirements

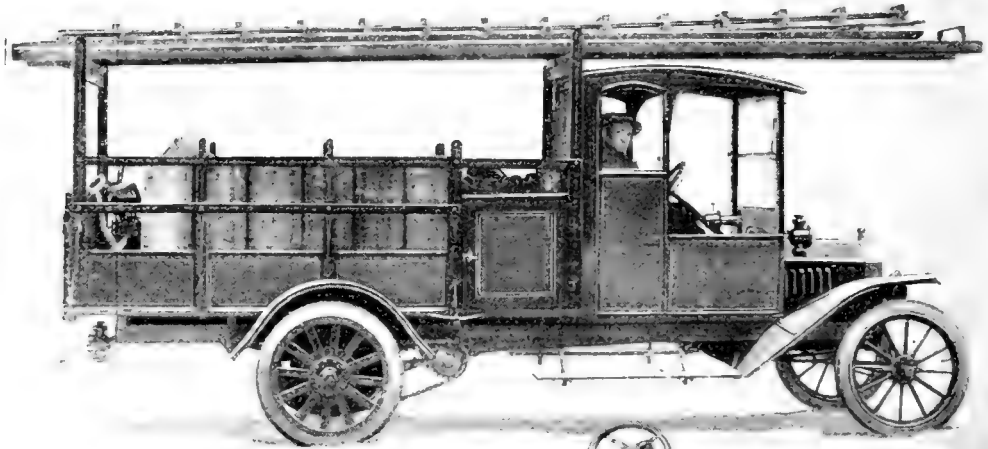

Above, when the installation is made the wheelbase is increased twenty-five inches and there is a large overhang of the frame behind the rear axle. To the right, we see how the Ford rear axle serves as a jackshaft, and how a chain-drive transmits the power to the new axle

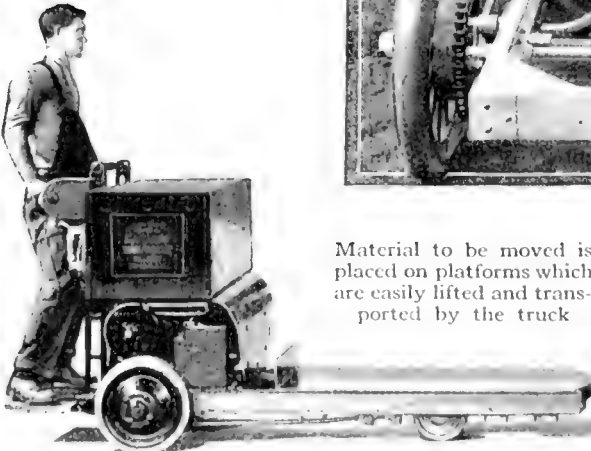
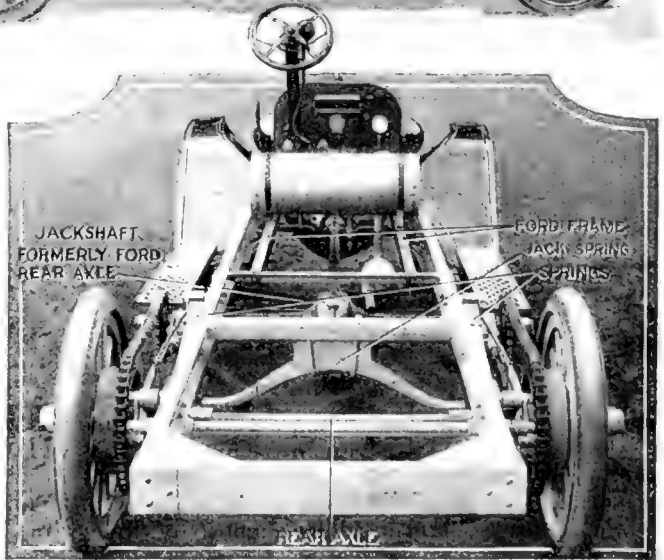

Material to be moved is placed on platforms which are easily lifted and transported by the truck





# The Newest Ideas in Motor-Trucks

By dividing this body into many conveniently located compartments, the driver saves much time, and a maximum mileage is gained

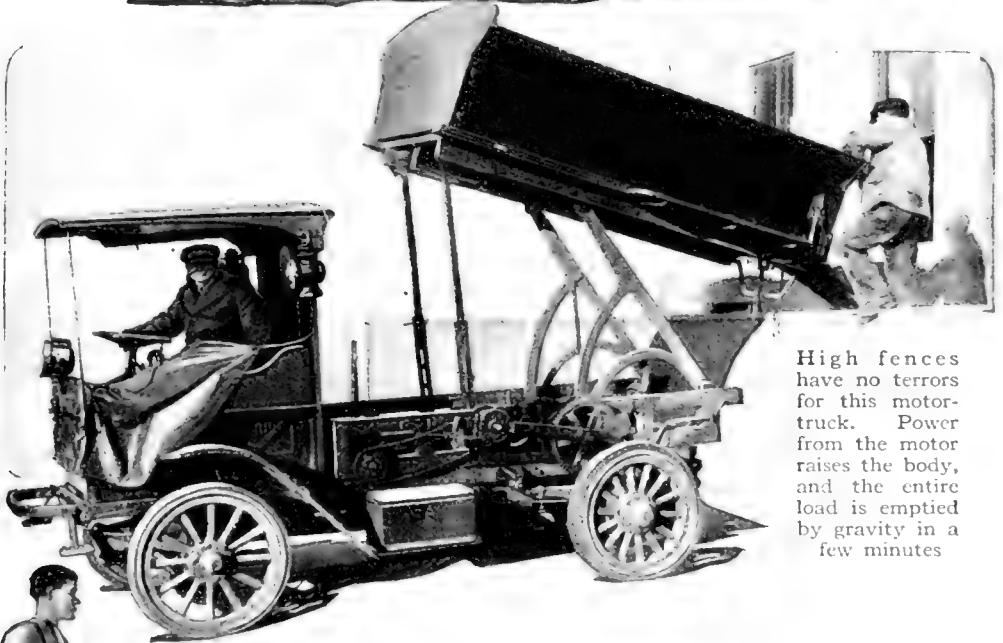
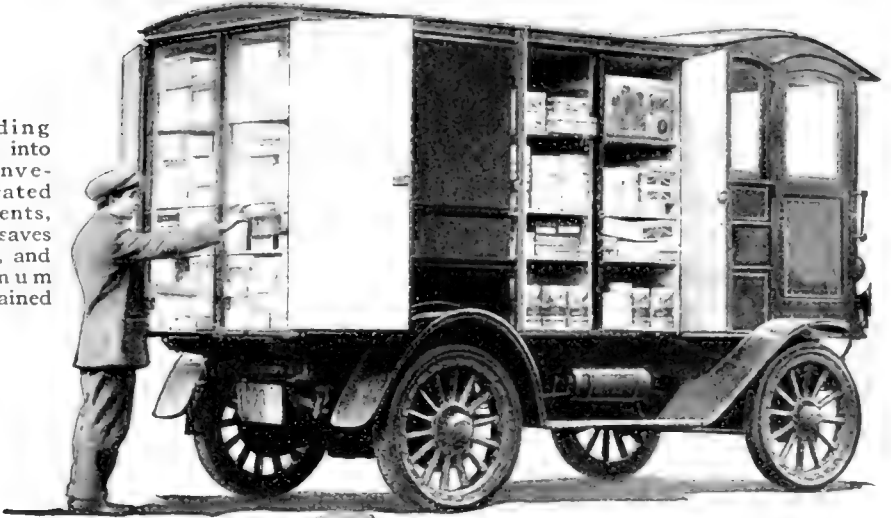

High fences have no terrors for this motor-truck. Power from the motor raises the body, and the entire load is emptied by gravity in a few minutes



The lifting platform of this truck, also shown on the bottom of the opposite page, will elevate and carry a load of two tons at a speed of approximately five miles an hour

# Beautifying Manhattan's Riverfront

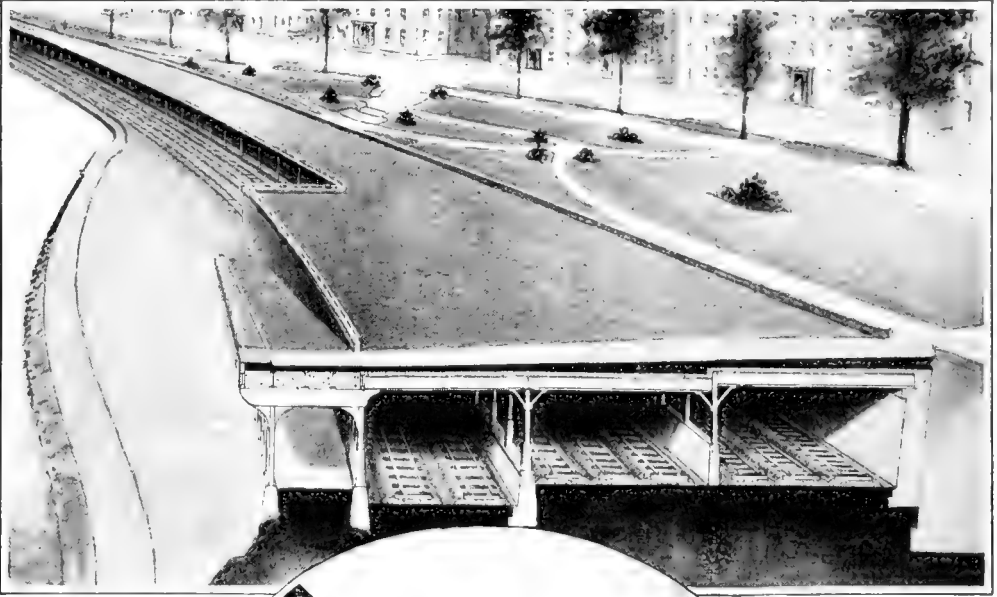

Where tunneling is impossible, covered subways will be provided. Paths will lead from the park proper across the subway to the river



View just north of Grant's Tomb, showing the proposed method of covering unsightly tracks and doing away with smoke and noise

**T**HE one blot on the beauty of Riverside Drive in New York city has been the tracks of the New York Central, running along the west side of Manhattan Island. For years vigorous protests have been raised against the nuisance, one newspaper referring to the railroad's right-of-way as "Death Avenue." Recently, however, the city and railroad authorities came to an amicable understanding, with the result that Riverside Park is to be forever freed of visible railroad tracks. The tracks are to be carried in tunnel or under roofed subway, with the park development over the top and on the outshore side. This will mean

permanent protection against the commercialism of the Riverside waterfront.

In the park and residential section, or above Seventy-second street, the tracks will be put under ground, and in the commercial section, below Fifty-ninth street, they will be placed on an elevated structure. This change will permanently overcome the grade-crossing evil and the city will have a parkway extending from Seventy-second street to Spuyten Duyvil, unmarred by railroad operation. In addition to this a new park at Inwood Hill, possessing natural beauties unsurpassed by any of the existing city parks, is provided. Fort Washington Park, at

present marred by an unsightly gash, is to be restored through the complete roofing of the railroad cut and the parking of the reclaimed area.

The city authorities insisted that the railroad company should turn most of its line into tunnels, and in most cases where tunnel construction is impossible on account of the slope of the land, should put the tracks in a covered subway carefully adjusted to fit in with the topography of the park. The design is such that it will allow effective parking along the entire right-of-way. As part of the settlement the railroad company agrees to pay a sum sufficient to restore the park to the edge of the river. Within the covered section of the area above Cathedral Parkway the railroad will construct a yard to take care of the business needs of the Harlem section.

In the lower elevated section the tracks will be placed so that there will be ample room between the new line and the steamship piers to build a two-track structure for the use of other railroads later. These tracks may form part of the proposed city-built West Side terminal. It will also be possible to provide railroad connections between the elevated structure and the second stories of the proposed new steamship piers.

The improvement represents an expenditure to the railroad company of something like fifty million dollars, and the city's loan contribution averages a little more than six million. When the park system is finished Manhattan Island will offer to the visitor within her gates the most highly improved and one of the most beautiful and costly pieces of land in the world.

#### Electrifying the Clam-Shell Bucket

A CLAM-SHELL bucket opened and closed by an electric motor is an improvement in loading machinery now offered by a New York firm. The motor, an integral part of the bucket, opens and closes the two halves through the aid of heavy chains. Should the bucket catch on a large stone in closing, a multiple-disk clutch comes into operation, and by slipping prevents the stalling of the motor and injury. Current is supplied through the use of a heavy electric cable, which is kept out of the way and taut by the use of an automatic winding drum, situated at a convenient point on the crane, or derrick. The drum has a series of springs inside and operates like a shade-roller, at all times supplying just enough tension to keep the power wires well out of the way. A controller of simple design operated by a lever convenient to the hand of the operator regulates the amount of current supplied the motor.

The advantage of mounting a motor on the bucket lies in the greater simplicity secured. Only one block and tackle is needed, and that simply for raising and lowering the bucket. Ordinarily,

additional tackle is necessary to control the opening and closing. Of course the motor dispenses with this arrangement. Another advantage is that the bucket is quickly detached from the hook.

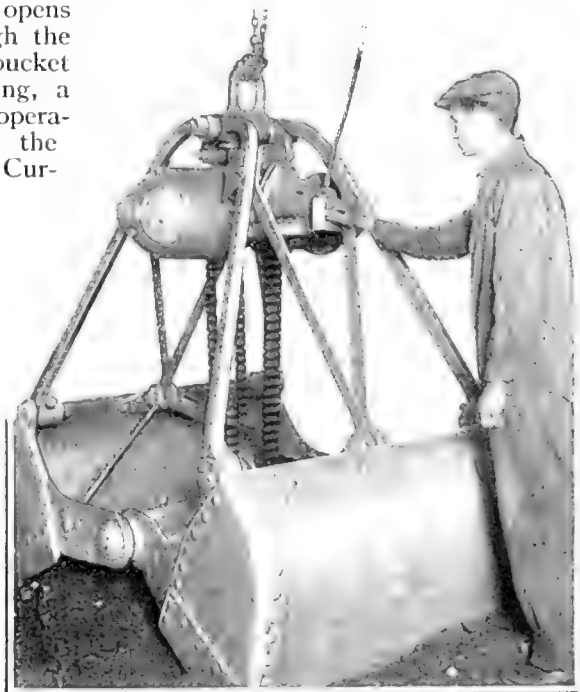

Note the motor on the clam-shell bucket. It opens and closes the two halves of the bucket with the aid of heavy chains. A multiple-hook prevents slipping

## Dipping Elk to Rid Them of Ticks

WHAT is said to have been the first time that a herd of wild animals was dipped in an insecticide as a means of ridding them of ticks occurred at Gardiner, Montana, recently, when



After the bath the elk gave a snort and returned to their haunts, free of ticks

the Forest Service undertook to ship about sixty head of elk that had been captured in the Yellowstone National Forest to points in the Rocky Mountain and Sopsis National Forests.

The herd was in poor condition as the result of a hard winter and was infested with "moose" ticks. It was feared that a large proportion of the animals would die unless the ticks were eradicated. Cattlemen doubted if the elk could be dipped, but Forest Service officials determined to make the experiment.

The elk were driven through a regular cattle dipping-pen, and each animal was entirely submerged in a strong insecticide. Less trouble was experienced than would have been the case with as many head of cattle, all of the elk taking the bath without fuss. The ticks were eradicated shortly thereafter and not a single animal showed any ill effects from the unusual experience.

## Ostrich Squab: A New Delicacy

WHILE the residents of Paris, not to mention the soldiers in the trenches, are giving thanks for the opportunity to eat horse-meat now that beef, mutton and pork are so scarce, a wealthy New Yorker in quest of novelty regaled his guests at dinner recently with an ostrich squab. The diners faced the unusual treat with some reluctance, but a taste proved that broiled ostrich is by no means an unpleasant dish. Its flavor resembled that of Virginia turkey, and the guests, after the first shock of the announcement was over, ate their portion of the bird with relish and approval. The ostrich squab came from California and weighed, when dressed, about ninety pounds.

The most quizzical factor about the unusual dinner treat concerned the ultimate destination of the ostrich "left-overs," for reports agreed that the bird was not entirely devoured. Whether



Laying bare the "drum-stick"—a full-sized meal without "fixin's"

the surplus parts broke into print by way of the hotel menu under their own or borrowed names or whether they helped to make up that great international dish of mystery—hotel hash—is a question yet to be decided. At least, the first meal was a success.

# Seeing the Unseen

## Looking at Things with Invisible Light

By R. W. Wood

Professor of Experimental Physics, John Hopkins University

*Professor Wood is one of the most distinguished of American physicists. He has recently attracted attention to himself by ingeniously photographing the common objects around us, as well as the planets, with light that our eyes can never see. Thus he has opened an entirely new world, the exploration of which teems with boundless possibilities. The following article from Professor Wood's pen explains as simply as possible how he conducted his investigation and what may be seen in the strange world that our imperfect eyes can never behold.*—EDITOR.

**I**F you could strike all the keys of a piano at once, from the deepest base note to the topmost treble, you would create a medley or cacophony in which it would be impossible to pick out one sound from another. White light is very much like that. It is a blending of many different kinds of light.

The analogy between light and sound is closer than may be supposed, if they are regarded merely as vibrations. The characteristic that distinguishes the lowest base note from the highest treble on a piano is pitch, and pitch depends on frequency of vibration. So it is with light. Low vibrations manifest themselves as red colors; high



A photograph taken with ultra-violet light reveals no shadows. White objects appear black, and everything seems veiled in a thin fog

vibrations as violet hues. Just as there is a perfect musical octave comprised of notes each having a definite pitch or frequency of vibration, so there is a light scale, manifesting itself in color notes, each also having a definite pitch or frequency. But while the frequency of the vibrations that produce musical notes is measured at the most by thousands per second, the vibrations that manifest themselves to our eyes as light must be measured by trillions per second.

There are sounds so thin and shrill, so highly pitched that only sensitive ears can hear them. Beyond them are notes that no human ear can hear at all.



The infra-red world is as strange as the ultra-violet. The sky appears black, foliage a beautiful rich red, and there are long, heavy shadows

With light it is the same. There are octaves of light which our eyes can never hope to see. Perhaps the best known of invisible rays are those used in wireless telegraphy; they are produced by vibrations of far lower frequency than those which we see as sunlight.

When you strike the middle "C" on a piano you hear a single musical note. And so, when you look at the world about you through a pane of red glass, you see things in a single light-note, as it were. Change the color of the glass and the world appears different. The same trees, the same flowers, the same houses are there, but with one color details are obscured and with another intensified.

It is perfectly possible to view the world with invisible rays and to learn things about which we never dreamed of in our philosophy: only we must use an eye, which, unlike our own eyes, will see the unknown world for us and make a picture of it which we can perceive. The ordinary photographic camera is

such an eye. The sensitized plate is extraordinarily responsive to those very high-pitched vibrations that do not affect the eye. All that remains is to strike the single note in a given octave of light, with which the world is to be viewed in order to see things as they are but as we never see them.

In order to see the world with invisible ultra-violet rays something better than glass must be employed; for glass is almost as opaque to them as a plate of sheet-iron. Quartz must be used, since quartz is transparent to them. Hence a quartz lens must be fashioned for the camera. To exclude all but violet rays from the lens a filter must be employed—a kind of sieve through which only the ultra-violet rays will pass, just as only red rays will pass through red glass. Some fifteen years ago I discovered that an aniline dye, called nitroso-dimethylaniline, would exclude all but the ultra-violet rays, the effect of which I wished to study. Thin films of silver are also serviceable, as well as the vapor of

bromine, contained in a rectangular transparent cell.

White ink made from Chinese white and written on white paper is practically invisible to our eyes. Photograph it with ultra-violet rays by means of the devices mentioned and it appears on the photograph as if it had been written with the blackest ink. Landscapes photographed by ultra-violet rays reveal no shadows. This means that the molecules of air or the particles of dust in the atmosphere completely scatter the rays, from which it follows that the greater part of the ultra-violet light that reaches the surface of the earth comes from the sky and not directly from the sun. If we saw only with ultra-violet light the world would appear as it does when a thin mist hovers over everything. We should, indeed, see the sun, but it would

It must not be supposed that there is but one ultra-violet light. There are indeed as many colors that we cannot see in the ultra-violet region as are visible in the rainbow. Unfortunately the camera and the sensitized plate do not give us true colors, as every kodak user knows; but they do indicate color differences in black and white. The photographs which I have made afford convincing evidence that there are a myriad hues in ultra-violet octaves. Thus all white flowers do not appear equally dark on ultra-violet photographs. White geraniums photograph much lighter than common white phlox.

In the opening paragraphs of this article light and sound were compared. It was stated that just as there are inaudible sounds there are invisible lights. There is a difference, however,

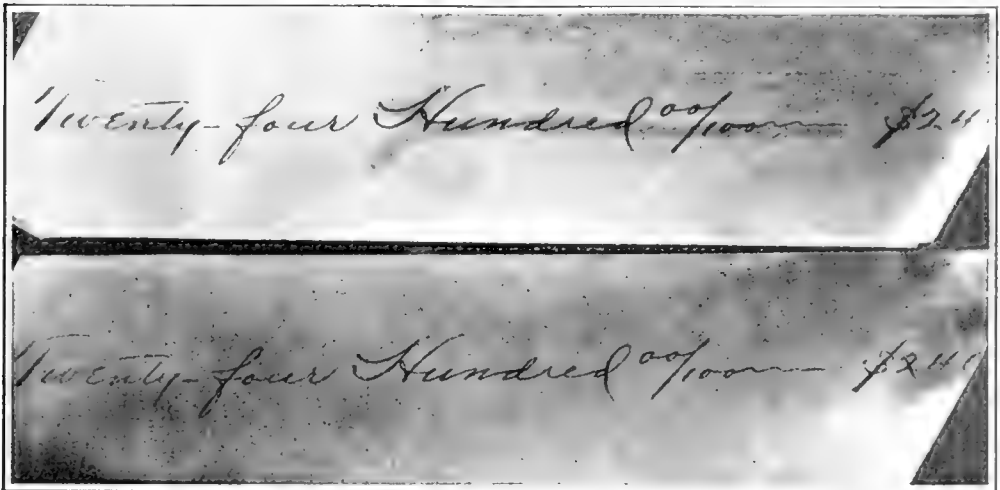

A check which was "raised" from twenty-four to twenty-four hundred dollars. The upper photograph, made with ultra-violet rays, shows the erasure plainly; the lower photograph, made by ordinary light, reveals nothing suspicious

be very dull, and there would be no shadows, just as there are none on a foggy day. Garden flowers which are white in the sun, phlox for example, become almost black. Who knows but this ability of white flowers to absorb ultra-violet rays may play some economic part in the growth in the plant? I made some experiments to answer that question, but without success. But who knows what the result would be after several generations of plants had been grown without the influence of ultra-violet light?

between the sound rays and light rays. As you go below the scale of musical notes, as you lower the number of vibrations, you hear not musical notes but distinct beats or blows. That happens when there are less than sixteen vibrations in a second. But—you hear. As you go down the light scale beyond red, the vibrations decrease in number by millions in a second. But—you do not see. In other words there is but one small octave of visible light. Above and below that octave we see nothing with our eyes.



It is obvious that the world is fully as well worth studying in light below red (infra-red) as in light above violet. When we reach the infra-red rays we are dealing with heat rays. A glass lens will answer our purpose in this case, but we must use a screen or color filter which absorbs all of the visible and ultra-violet light, while transmitting the infra-red.

As the camera reveals it, the infra-red world is as startling as the ultra-violet world. The sky appears in photographs as black as midnight; foliage snow white. The shadows are intensely black, simply because most of the light comes directly from the sun and not from the sky.

Applied to purely scientific investigation this utilization of infra-red and ultra-violet rays has vast possibilities. I have made photographic studies of the heavenly bodies

with invisible rays, and the results obtained prove convincingly that many new facts can be reached in this way.

The Moon is a dead, arid, airless body which has long ceased to interest most astronomers. Every one of its many thousand extinct craters has been plotted; its great mountain ranges have all been named; and its so-called "seas" and basins have been mapped. It seemed impossible years ago to add anything substantial to our knowledge of the Moon. I made some experiments at my summer home on Long Island

with a horizontal reflecting telescope of fifty-six-foot focus and fourteen-inch aperture to ascertain what might be revealed if the Moon were photographed with ultra-violet light. While there is very little difference between ordinary photographs of the lunar surface and those made with ultra-violet

radiation alone, there is enough that is significant. The brightest of all extinct lunar craters is called Aristarchus. Photographed with ultra-violet rays, Aristarchus shows a dark patch which is not to be seen on a photograph made with visible light. I made an enlargement of the region in which this crater appears, and it is evident that there is in its neighborhood a large deposit of some material which can be revealed only by ultra-violet rays. These photographs of the Moon prove



Photograph taken with infra-red light. Note the black sky, the white trees silhouetted against it, and the deep shadows

that by systematically studying the lunar surface with invisible rays, we may some day discover what the Moon is made of almost with as much certainty as if we could analyze a piece of it in an earthly laboratory.

In the late autumn of last year, through the courtesy of Professor Hale, the great sixty-inch reflecting telescope of the Mount Wilson Observatory in California was placed at my disposal for four nights. The instrument is the largest of its kind in the world. Photographs of Saturn and Jupiter were made



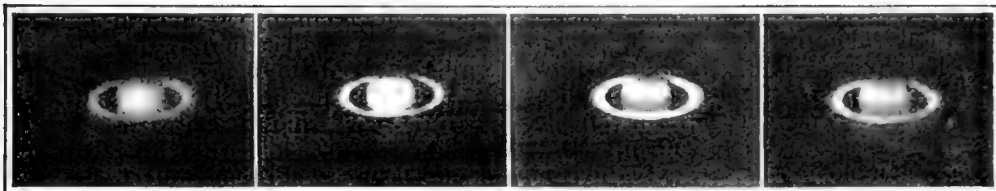

Infra-red                      Yellow                      Violet                      Ultra-violet  
 Photographs of Saturn made by Professor Wood with various rays, showing how much more is revealed by some rays than others

by means of infra-red, yellow, violet and ultra-violet light.

Both Saturn and Jupiter are striped with belts which have been the subject of much discussion among astronomers. Study the accompanying photographs and you will see how different is the aspect of the planets when photographed with different rays, whether visible yellow or invisible infra-red or ultra-violet. The belts on the ball of each planet, which can be seen with the eye in a telescope and which are very distinct on photographs made with visible yellow rays, vanish almost completely when photographed with infra-red rays. When ultra-violet light is used a remarkable transformation of the planets occurs. A broad dark equatorial belt surrounds each planet, and a large dark polar cap appears. This equatorial portion is the brightest part of each planet when photographed with visible yellow light. When ultra-violet is employed the bright belts vanish. The equatorial dark belts are still recorded, but they are slightly narrower than when photographed in violet light. Moreover the dark polar cap has decreased in size.

Variations in the intensity of the inner and outer ring of Saturn are also shown in the different photographs. The surface features of both Saturn and Jupiter have been repeatedly photographed, but not with the result of

adding much to our knowledge. At last we have a method which may enable the astronomer to interpret the puzzling belts intelligently. It is much too early to venture an opinion. Much work remains to be done with the spectroscope. Perhaps it may turn out that the bands of Saturn may be due to some substance which has not been made in any earthly laboratory or to some substance, which has never been studied in layers thick enough to bring out the characteristic appearance. It is also possible, though hardly probable, that the belt is due to a fine mist or dust which absorbs violet light; but it seems unlikely that such a mist would appear dark for the simple reason that it would reflect equally as much light as it absorbed. As a venture we might attribute the belt to chlorine gas, which absorbs violet and ultra-violet light powerfully and is transparent to yellow light. When we recall the enormous quantity of chlorine locked up in the salt of the ocean it is perhaps possible that large quantities may exist free in the atmosphere of young planets like Jupiter and Saturn.

It seems highly probable that extremely valuable results may be obtained if these methods are applied to the planet Mars. Unfortunately, at this time Mars is too far away, and the photographs which I made show nothing of interest.

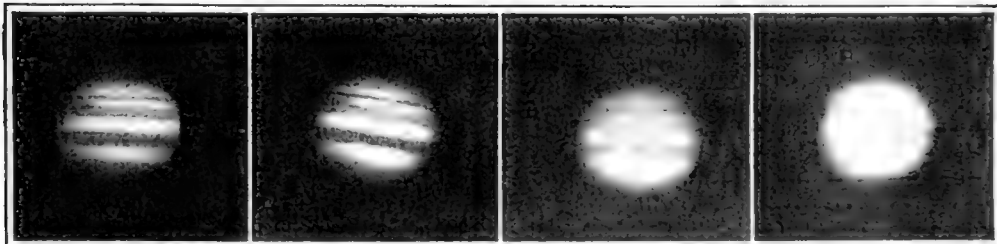

Infra-red                      Yellow                      Violet                      Ultra-violet  
 Photographs of Jupiter made by Professor Wood with different rays

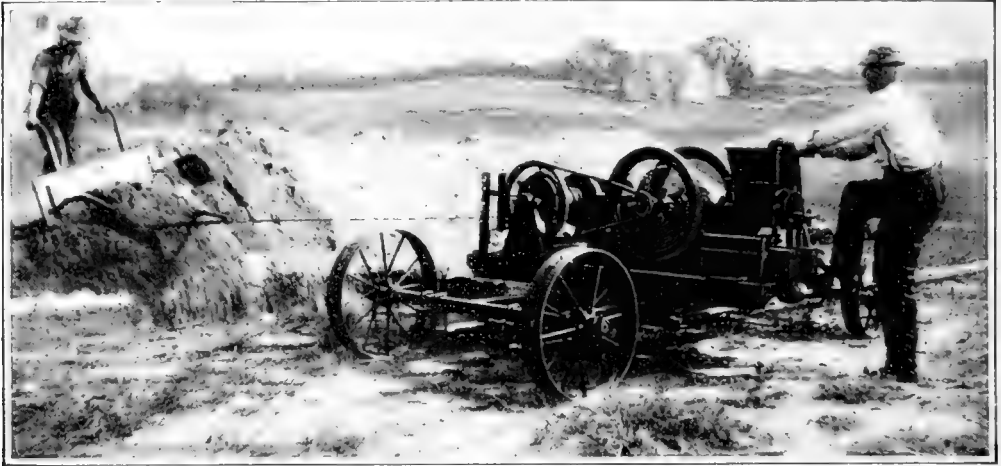

Trenches are now excavated and filled by machines. The filling-machine operates the scraper at a rate of speed wholly beyond that attainable by a man and a team

#### Filling Trenches by Machine

**A**N advance step has been taken in the construction of sewers and the laying of water-mains. With the modern trench-filler no time is lost in refilling the excavation. The contents of the deepest and longest earth opening can be put back in double-quick time.

The new machine is a gasoline-engine which drives a windlass by means of which a steel cable is wound. To the end of the cable is attached a steel scraper. The engine and equipment are mounted on a movable truck. Such is the construction that the machine can be used either on the truck or can be removed entirely by simply taking several bolts out of the turntable.

The new apparatus readily adapts itself to several other uses in connection with trench operations. It is used to pull heavy cables through conduits, to raise and lower giant telephone poles into their respective places, as well as to load and unload pipe and place it in trenches.

The engine is of four and a half horsepower. It operates the scraper at the rate of one hundred and fifty feet per minute in ordinary soil and one hundred feet per minute in heavy clay. The speed is regulated to suit the soil by a change of sprockets on the engine's crankshaft.

The crew for operation consists of two men—one to pull the lever control-

ling the windlass and the other to handle the scraper. The instant the scraper reaches the edge of the trench the power is released, and the helper draws the empty scraper back to position ready for another load.

#### The Amazing Beetle

**O**NE of the most amazing things in natural history is the way in which beetles have triumphed in the struggle for existence. Of all creatures they are by far the most numerous, no fewer than 150,000 distinct species having been identified—three times the number of backboned animals.

Beetles are wonderfully adaptable. They are found practically everywhere—in the frost-bound tracts of Iceland and in the hot desert sands of Africa; on the highest mountains, under the ground, and as fossil, in the deepest strata; on land and in water; on plants, among stones, and in wood and earth; and even in the very craters of volcanos.

But there is one place where no beetle has yet been found—it is the inhospitable land of Spitzbergen, to the north of Russia. Here are mammals, birds, fish, mollusks, crustaceans, a few insects of varied species, and many spiders, but not a single beetle. While other insects have succeeded in some way in migrating from the mainland, the beetles have apparently been unable to cross the wide, icy waters.

# Insect Carpenters and Masons

By Edward F. Bigelow

**T**HE young naturalist who lies face downward at the brookside, and with shaded eyes watches the busy life that there has its being, will see, in many places, little masses of small stones or bundles of small sticks, moving on the bottom of quiet pools as though they were alive. When out of the water they seem to be only groups of stones or clusters of sticks, motionless and dead. But they are the homes of living larvae. By putting them in water or by pulling them apart, a whitish habitant is discovered—a larva which is a dainty morsel much relished by fish. Nature has provided it with an ingenious means of protection. The little caddis fly larva is an exemplification of the old saying that “necessity is the mother of invention,” since the little animal does not always build as his ancestors built but adapts himself to the circumstances of a new environment and utilizes whatever material may be available. In some localities the cases are made of stones; in others of short twigs; in still others, some of the little builders and mechanics

bore out the interior of a slender twig or straw and use the hollow as a protection against the enemy fish.

When caddis flies are placed in small aquaria they extend the body out of the front of the protecting case and carry it as they crawl. But jar the receptacle and the larva instantly retreats into its house. It is hardly possible to pull the little creature out of its case, except possibly from the smooth straw. It clings to its covering with peculiar tenacity by means of two hooks at the rear extremity of the body. So firmly is it anchored to the sticks that violence will not dislodge it, unless the force is sufficiently great to pull the insect in two.

But the larva may be driven out by using a tiny toothpick with a blunt end, or by anything else of the kind that does not terminate in a sharp point. Push this into the rear of the case and the little animal at once unhooks himself and hastens out to find a new home.

Usually the cases are straight but sometimes they are curved, and a few

spiral forms have been found, which closely resemble minute snail-shells. The dweller in this rude retreat is a fisherman who not only builds a home of sand but uses the sand to make a funnel-shaped trap faced by a silken net. The funnel is directed upstream. At the entrance the net has almost rectangular meshes, often in beautiful regularity, and appears much like a delicate spider web in the water. This ingenious contrivance is placed in

Little masses of small stones or clusters of sticks, motionless and dead, are the homes of the caddis fly larvae much relished by fish. These tiny dwellings actually move about as if alive in the water, but show no signs of animation on dry land. It is a difficult matter to induce the larva to leave his safe retreat

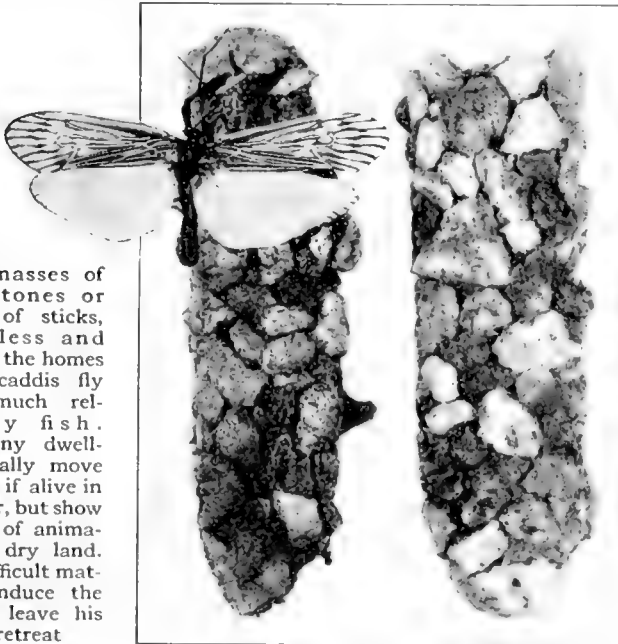

the swiftest current, and in rapids between stones. Sometimes they are found in great numbers along the brink of a waterfall. The observer must look carefully to see the net, as it is usually obscured by the dirt that collects and adheres there in little masses. But if he is so fortunate as to find one recently completed, the net-like formation is clear and beautiful.

In some places empty cases may be seen at the edge of the brook. Often they almost completely cover the rocks and the earth between them. In such instances the insects have emerged at

### Selling Cars Under the "Big Top"

**T**HE "BIG TOP" is the circus man's term for the main tent with the three rings. One of these huge spreads of canvas has been taken over by a Los Angeles dealer in used cars to sell everything propelled by motors.

The tent will hold five thousand people, and it has a display capacity of five hundred cars, trucks and "jitneys." There is an oval track one eighth of a mile in circumference, and the machines go whizzing about this as if it were an indoor speedway contest. The crowd looks on from the central en-

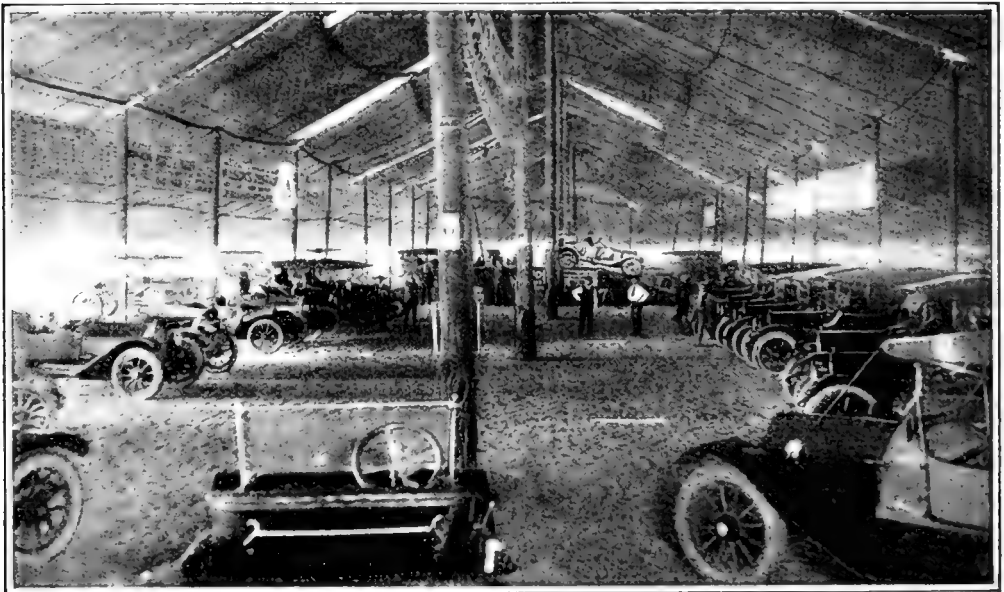

A circus-tent now used as a market-place for second-hand automobiles. A twenty per cent incline in the center demonstrates the climbing ability of the cars

the time of a freshet and the retreating water has left the cases stranded high and dry. The two empty cases here illustrated were obtained in this manner. They were selected from a large number because they are perfect examples of what the mason calls ashlar work, that perfect fitting together of stones without packing. Common as are the caddis worms and as often as they have been observed, not a single one has had its life history recorded in this country. A fascinating field for original investigation is here open to the first comer. Endeavor along this line is sure to be interesting.

closure and judges the merits of the used cars by what they can do—not by fresh paint and varnish.

An additional test is afforded by the twenty per cent incline in the center of the arena. Here the car shows what it can do on a grade. This platform is also used as an auction block for crowded twice-a-week sales. The machine whirls about the track, runs up the incline to the elevation well above the heads of the spectators, and is then knocked down to the highest bidder.

Private sales continue all through the week. A dozen salesmen are employed.

**Electric Plant  
Run by an  
Artesian Well**

**A**RTESIAN, flowing, or spouting wells are widely used for irrigation in the West, and for general water supplies in various parts of the country, but seldom is a single well made to serve such a variety of purposes as the one shown in the photograph,

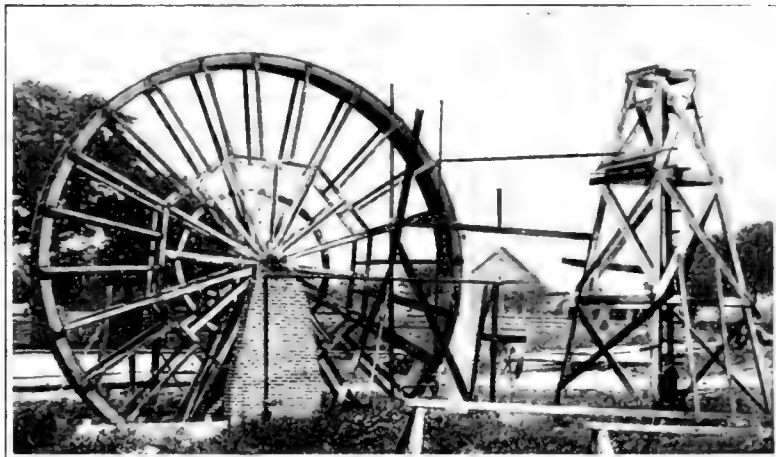

Electric current enough is generated by this plant, run by an artesian well, to operate a farm-mill, feed-chopper, lathe and other machinery used on the farm

simply because it drives the machinery of an electric plant. The well and plant are located on a farm near Midville, Georgia. Such is the water pressure that current enough is generated to supply the house and barn with light, and power for the running of a farm mill, feed-chopper, lathe, a clothes-washer and several other labor-saving devices for the house, such as are generally operated by progressive farmers with small gasoline engine plants.

The well furnishes an ideal water supply for the farm and house, the water being piped to a submerged tank under the house, which supplies both stories on tap. The water thus does double duty. Since the supply from the well is ample, the owner is contemplating the irrigation of about an acre of garden land from a small concrete basin or reservoir into which the water can be run from the well and allowed to warm before reaching the land.

**Air-Propeller Drives Bicycle**

**A**SURE way of making the other fellow, including the motor-cyclist, take his dust, is open to the bicyclist

with an air-propeller driver by a two-horsepower engine compactly mounted on a rear frame attachment. The manufacturer was so pleased with the results attained by his propeller fitted to rowboats, canoes and small, light vehicles, that he adapted his device to bicycles. It is claimed that, fitted to a four-wheeled truck known as a "motor-bob" or "wind-wagon," a speed of thirty miles an hour has been made.



With the air-propeller attachment a speed of thirty miles an hour has been attained

Since the mechanism is mounted on a rear frame there is little engine vibration. The fuel tank is situated under the saddle, and the speed is controlled by wires leading from the engine to the handlebars. A bicycle equipped with an air-propeller will afford much pleasure to the user.

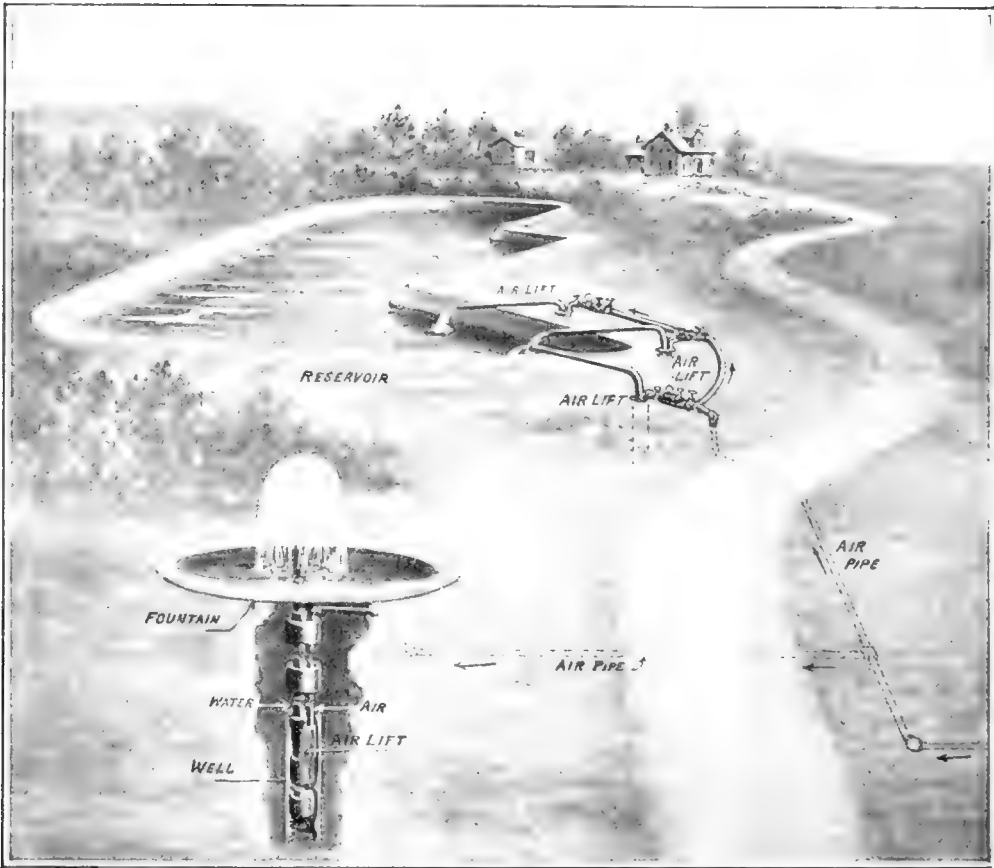

An air-compressor supplies air to a chamber surrounding the water-pipe in the well. The air passes through small perforations into the water, producing bubbles which rise slowly

## Making Water Pump Itself

**D**OES water seek its own level? Yes, with an *if*—if the water is the same density throughout. If the density of water in two connecting vessels differs, the level of the lighter water will be higher.

There are different ways in which density can be affected. One is by heat; another is by adding to the water something that is lighter than itself—air, for instance. This can be shown in a very simple way with a tea-kettle and a short tube. Fill the kettle with water and insert the tube in its spout until it nearly touches the bottom of the spout. Then blow bubbles into the spout through the tube. The bubbles will mix with the water in the spout and lighten

it. The solid water in the kettle will then overbalance the lighter aerated water in the spout; the heavier water in the kettle will force its way into the spout in an endeavor to establish equilibrium, and the spout will overflow. The water will continue to flow from the spout until the water level in the kettle becomes so low that equilibrium is established. Then the flow will cease. It is apparent that the force of the air has little to do with the action, for the air is blowing *against* the direction of flow of the water. The water really pumps itself.

Keeping the case of the kettle in mind, we will now see how it suffices to illustrate the principle of the air-lift.

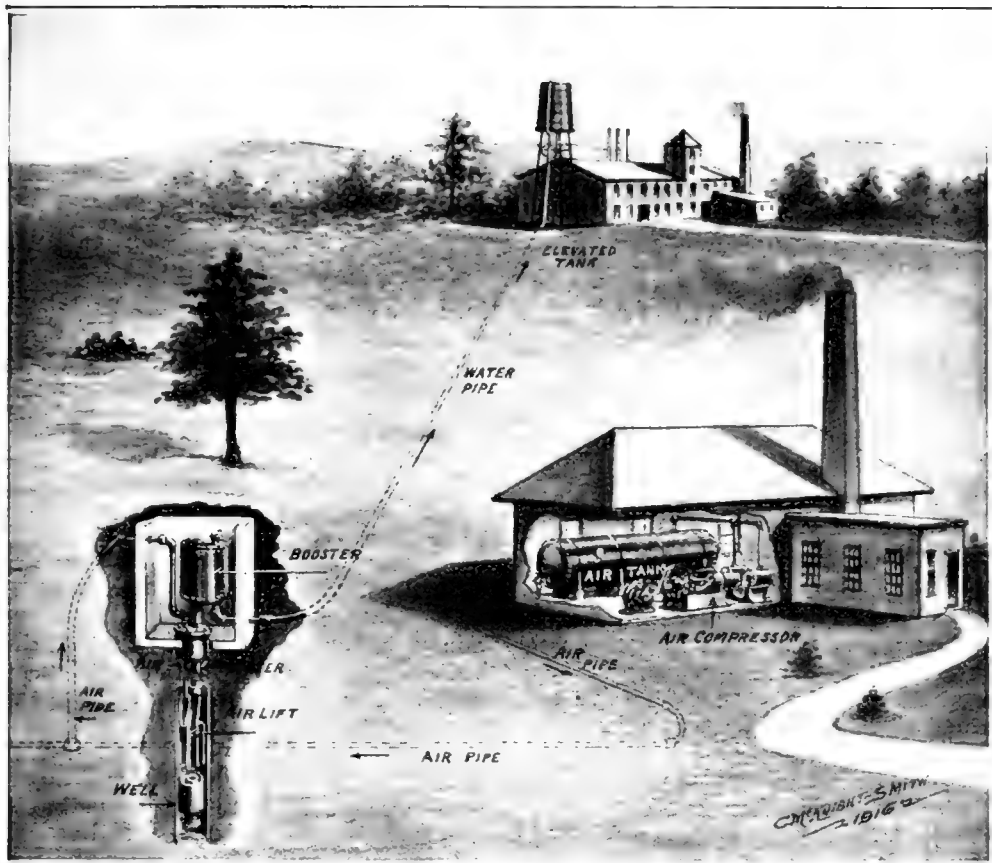

and which are distributed through the water in the pipe. The greater weight of water in the well overbalances the aerated water, and is forced upward and discharged

One or more wells are sunk to a depth considerably below the level of the underground water. A pipe of large diameter open at the bottom is then sunk nearly to the bottom of each well. This is for the water discharge. When not pumping, the water in this pipe will be at the same level as that in the well. A second pipe of small diameter is also sunk to the bottom of each well, terminating in a chamber which surrounds the water-pipe. Air passes from this chamber through small perforations into the water-pipe, mixing small bubbles with the water, giving a "champagne effect." These bubbles rise very slowly, until they are distributed throughout the entire column of water in the discharge pipe. Coincident with the admission of air, the column of water elongates until it discharges.

The weight of water in the well over-

balances the very much longer column of aerated water in the pipe. Thus the well-water flows into the discharge pipe, is aerated and in turn discharged.

The air pressure must be greater than the water pressure at the bottom of the well. Otherwise the water would force its way into the air-pipe and stop operations.

The water may be lifted vertically into a tank or reservoir or may be discharged into a "booster" and then carried horizontally. The booster is simply a vessel which permits the air and water to separate.

In the air-lift system there are absolutely no working parts, such as pistons, valves, etc., under ground, which are liable to wear, to rust, or to become defective with use. Air is supplied by an air-compressor, which may be located far from the wells, if desired





Everything was there but the engine and they substituted a burro for that

#### A "Jackomobile" for Two

THE illustration shows a combination of the oldest and newest means of transportation. In 1904 it was a new automobile, but in subsequent years it fared so hard at the hands of one owner after another that its engine was

discarded and the machine itself was on the way to the dump heap when two boys assumed ownership. They obtained a burro and after fitting the body of the old model with shafts, went about their Michigan town with the only "Jackomobile" extant.

#### The Milk-Can Trolley

FOR the rapid and economic handling of milk a Western creamery has installed an aerial tramway, six hundred

feet long, leading from its milking barns direct to the refrigerating and bottling plants. The milk travels over the top of stables en route, and a complete trip of one five-gallon can on a two-wheeled carrier takes but seventy-five seconds. Formerly this work was done by a driver with team and wagon. The tramway has taken their place.

There are always two cans in transit at the same time, one coming in full and one returning empty. The attaching links are so spaced that when the full can has reached the end of its trip at the bottling house, the empty can has also reached its destination at the milking barn and stops at the proper place, automatically. The drag-cable is driven by a reversible set of small drums having grooves to receive the cable. Signals to start are given from the barn by a magneto bell.

For dairies which handle large quantities of milk and make express shipments to large cities, this conveyor is a great step in advance, since it reduces the time required in handling the milk.

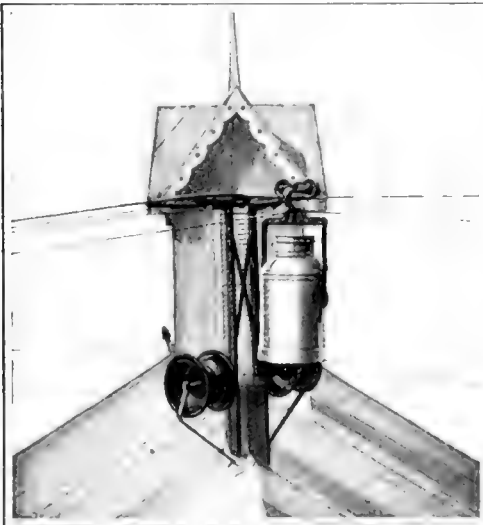

The apparatus in position, showing the carrying and traction cables. Two cans are always in transit



Straw Raincoats of Japan

THERE are as many different kinds of alleged waterproof raiment in existence as there are straws in the grotesque costume of the Japanese in the accompanying illustration. But there is just one raincoat which lives up to its rainproof claims, and, in fact, has lived up to them for a thousand years and more, and that is the rice-straw combination worn by the Nippon.

In addition to being light, porous and warm in cold, wet weather it serves as a "blind" for the wary fish which can discern no danger lurking in a fishing-pole protruding from what appears to be a mere sheath of grass. A Nippon angler seated on a river bank wearing his rice-straw cloak resembles so closely a tuft of rank grass or a growing scrub that the most preyed-upon animals fail to detect danger.

From the score of waterproof materials and impervious clothing there is a new Paris product which is said to be very effective, providing one doesn't approach too close to the fire. It is highly inflammable on chance ignition, since its inner lining is composed of guncotton sheeting. There is also an English raincoat which weighs but nine pounds when dry, but

which, when worn through rain, will absorb water as readily as a sponge. In an hour it has been known to absorb six pounds of water, adding greatly to its weight and accelerating physical exhaustion. Yes, it's waterproof.

What? Only Three Kinds of Feet?

A RECENT meeting of foot doctors brought forth the information that all feet are divided into three classes, namely, inflared, outflared and straight—the first two classes being scientific divisions for the common afflictions known as pigeon-toes and bow-legs. One doctor said: "Shoes are proverbially made to fit the eye and the pocketbook, but not the feet." In other words the manufacturers have not kept step with the times by making shoes of three classes.

The ordinary classification of boots, shoes and slippers does not fit with the inflared, outflared and straight classes of feet, stated the doctors, as was proved by the fact that most manufacturers ride in automobiles. To remedy the situation it is proposed that all shoes be manufactured to conform with the three general classes of feet, that both feet and shoes may advance side by side in the scale of civilization.



The rice-straw cloak on this Japanese is the oldest as well as the most effective of all the various kinds of waterproof clothing extant

# Photography in Natural Colors

By Lloyd Darling

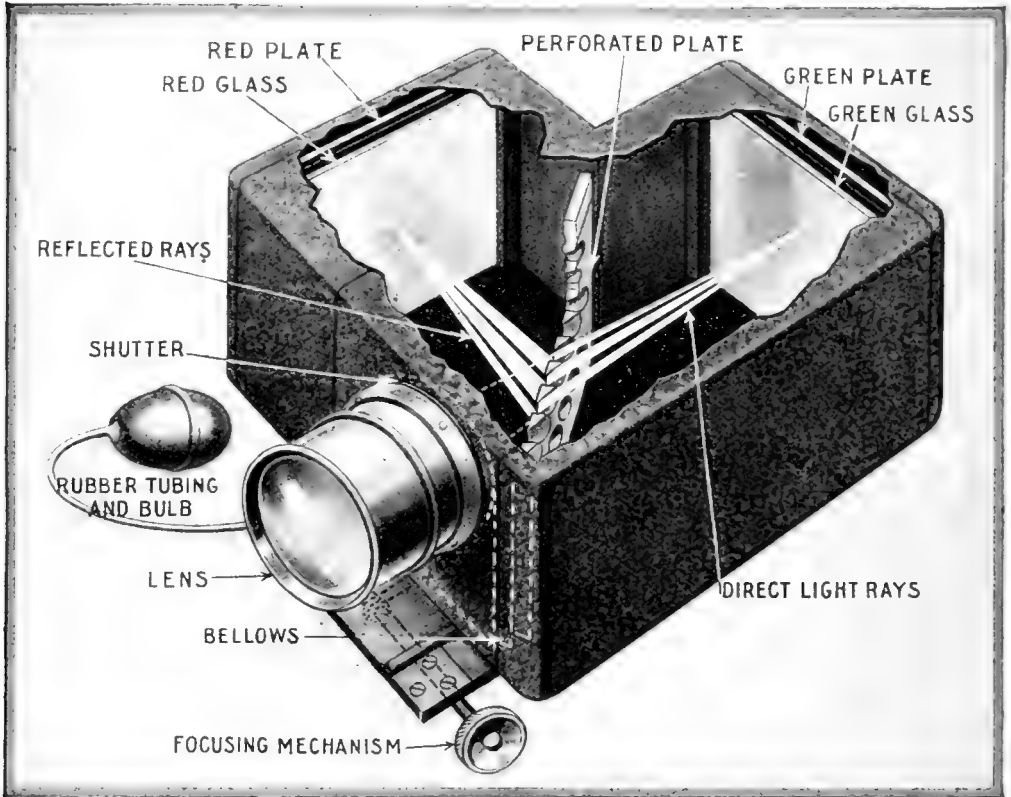

The Brewster camera, showing the red plate, the green plate, and the perforated partition

COLOR photography is not new. It has been the goal of ambitious inventors ever since scientists really understood something of the nature of light. Nearly all methods of making colored photographs are long and expensive. Though beautiful results were in some cases secured, only an able scientist could manipulate the apparatus, time the exposures, and keep track of the dozens of little things all-essential to securing satisfactory results. Even the Lumière process, widely employed as it is, is handicapped by the fact that the pictures must be viewed through glass.

Most of the previous processes were of the "three-color" type. That is, they depended on the fact that from three colors of the spectrum, red, yellow-green,

and blue-violet, all other hues could be made by combination. Negatives of an object were made through red, yellow, and blue filters, and positives therefrom were colored and joined in various ways to make a resultant colored picture.

Within recent years encouraging experiments have been made which involve the use of two colors only, red and green. The most recent system of color photography dependant on this method is that of Mr. Percy D. Brewster of New York.

## *Two Plates Are Used with the Camera*

The camera employed in the Brewster system and other two-color systems differs from the ordinary photographer's mainly in that it has two plates instead of the customary one. The one

directly back of the lens is known as the "green" plate; while the other at right angles is referred to as "red." This arises from the fact that light rays reaching the "green" plate must first pass through a green filter, while those falling on the "red" plate are correspondingly filtered by a red glass. The "green" plate is intended to record at the green portion of the spectrum, while the "red" is sensitive to those at the opposite end.

The manner in which the image is conveyed to both plates is interesting. Thus, Mr. Brewster mounts, a few inches back of the camera shutter, a mirror called the "Swiss Cheese" plate, its surface being at a 45° angle with the plane of the lens. The mirror is thus strangely named because it is full of holes, which serve to permit parts of the image to pass through to the "green" plate; the remainder being reflected by the solid part to the "red" plate. Inasmuch as images filtering through the holes overlap after passing the mirror, a complete picture is thrown on the "green" plate—and not a spotted one, as might be expected because of the holes. Likewise the solid portion throws a complete image on the "red" plate. Dividing the light between the two plates in this manner of course lengthens somewhat the time of exposure necessary; otherwise no other effects are ordinarily noticeable.

The same effect can be obtained in many other ways. Thus, in what is known as the "kodachrome" process a plate is employed which, instead of being perforated with Swiss cheese holes, is thinly platinized, so that it can both reflect and transmit light.

It is understood of course that negatives obtained with the Brewster, "Kodachrome," and similar instruments are of the ordinary black-and-white variety—not colored in any way. The "green" plate differs from the ordinary negative only in the fact that it is especially dense where colors at the green end of the spectrum predominated, while the "red" plate likewise records densely roseate hues. From these two negatives positives are made on other plates by ordinary processes of contact printing. The image on the positive from the "green" plate is dyed red and that from the "red" plate green. The two positives are then placed face to face, and the image on one registered with the image on the other.

Hold the combined plates up to the light, and you can see the photographed object in its natural colors. It stands out from the background as striking as the original. The effect is startling, indeed.

*Why Two Colors Must Be Employed*

The reason for coloring the "green" positive red, and the "red" positive green, as mentioned in the foregoing, is rather elusive and at the same time particularly interesting. Consider for instance the case of a red rose on a background of green leaves. The "green" negative upon development will be almost black where the green leaves appear on the plate, while the rose will be almost transparent. Similarly with

the "red" negative, the rose will appear dense, while the green is recorded as a transparent area.

Positives from these two plates will in each case of course be just the opposite

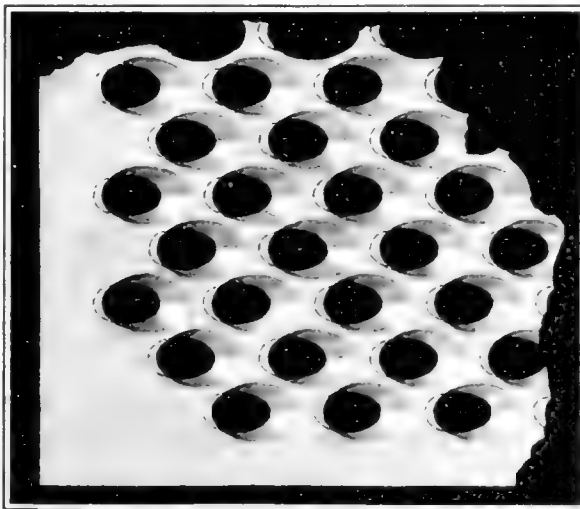

The "Swiss cheese" mirror. The dotted lines indicate the size of the holes on the reverse side

of the negatives. That is, a positive from the green plate will show the leaves transparent, and the rose dense; while that from the "red" plate will show the leaves dense, and the rose transparent. Dyes used in this process affect only the dense places. It is obvious that if you want a red rose to be red in the resultant picture, you will have to color the positive from the "green" negative red, that being the only one showing the red rose as a dense area. Similarly, you will have to color the positive from the green negative "red," since in this case the leaves are dense. After dyeing them in this manner, the plates pass through a special process to eliminate the opaque black silver on the plates, leaving only the colored images. This process completed, the two plates are placed face to face and registered

properly. Then you see the red rose in its proper place among the green leaves.

The next step is to cement these two positive emulsions together. This done, they are stripped from the glass and transferred to paper, canvas, ivory (in the case of a miniature), or any other backing. In their new positions they look not unlike an oil painting, especially when canvas is used as a mount.

For the sake of simplicity, the foregoing description of the red rose and green background referred only to these two colors. It is understood of course that almost any color which may have been present in the original object also appears in the finished picture. This is possible because red and green combined in different proportions by the process here used will give such desired colors.

### How a Steamer's Engine-Room Is Ventilated

PHYSIOLOGISTS have shown in recent years that the chief effect of ventilation and open air treatment depends on the movement, temperature and moisture of the air, and less upon its chemical properties than was expected. For this reason the cooling of overheated engine-rooms, underground or underdeck, is best obtained, as engineers have discovered, by flooding them with fresh air from outside under slight pressure. This positive ventilation or a continuous change of air also removes all noxious gases and smells emanating from the oil and bilges.

The accompanying drawing shows a transverse sectional view of the engine-room of the "Aquitania," with the recommended method for flooding the confined space with cool, fresh air under moderate pressure. The air is delivered

into the engine-room by a large open fan placed at the junction of the lower ends of the air-shafts, so that the full volume of fresh air, equal in this instance to about one hundred and fifty thousand cubic feet per minute, is propelled into and properly distributed through the engine-room without loss from delivery ducts.

When desirable, the air in the engine-room may be changed one hundred and twenty times an hour without uncomfortable drafts. The cool air is drawn, not forced, down from the upper deck and delivered laterally by open fans placed low down in the engine-room so as to flood the whole space with air, the cooler incoming air falling towards the floor, displacing the heated air and expelling it up the main hatch. Many transatlantic liners have the ventilating system illustrated.

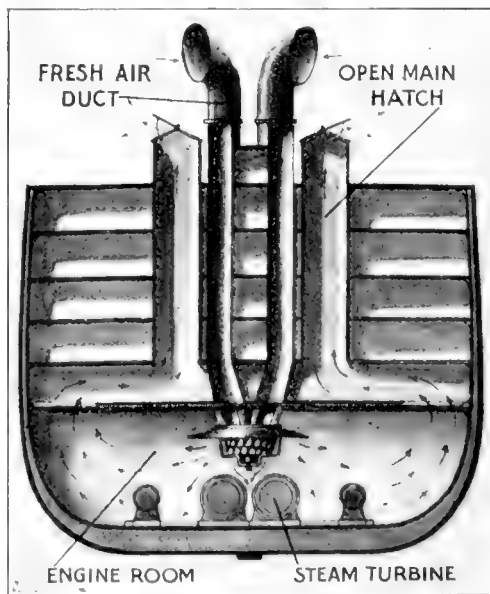

A cross-section view of the "Aquitania," showing ventilating arrangement

# What Inventors Are Doing for the Fisherman

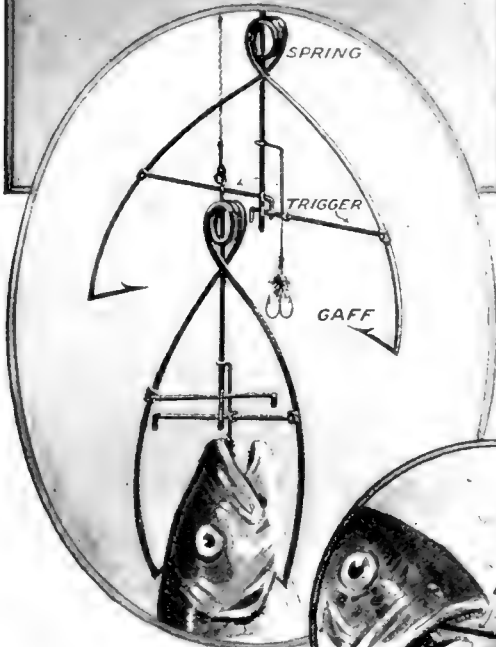
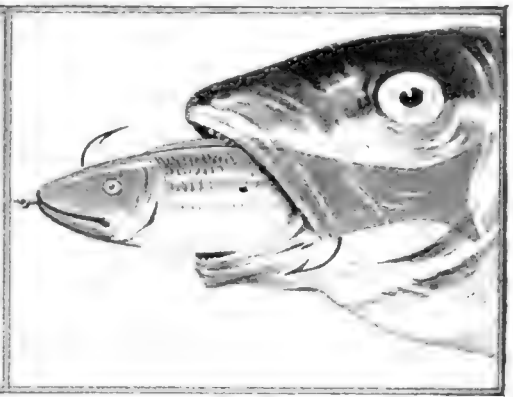
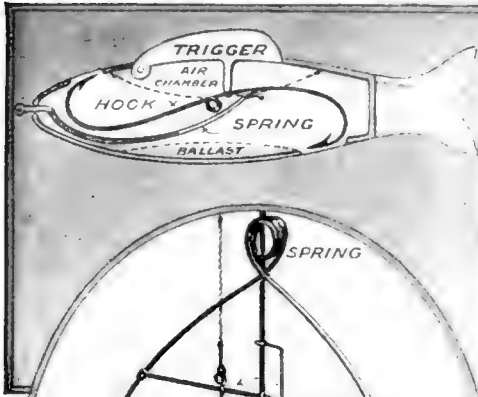

Weedless artificial bait is shown in the upper left hand corner and above. The air-chamber and ballast cause the hollow metal fish to float horizontally. The wire spring holds the points of the double hook concealed within the body of the bait. A fish grasps the bait by the dorsal fin, depressing it, and the lug forces the points of the hook out of the slots into the fish's jaws. Many species of game fish fight shy of dorsal fins, grasping their prey more to the rear, but this bait is effective, nevertheless

Above, automatic spring gaff trap which embeds barbed ends in the sides of the fish pulling the trigger

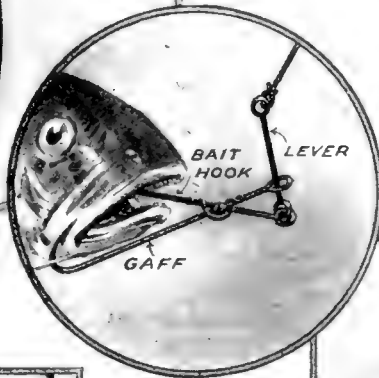

Above, a lever-actuated trap hook which barbs the fish pulling the bait. The trap is operated entirely by leverage, the small spring at the pivot joint serving to keep the two hooks separated

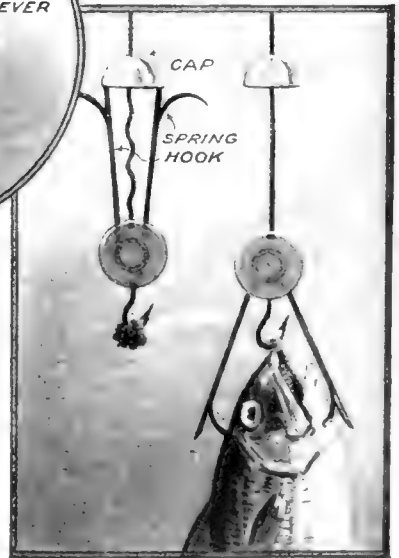

Above, the spring hooks are bent back and held set under a hollow wooden cap. A bite pulls the hooks down and the action of the spring forces them into the fish

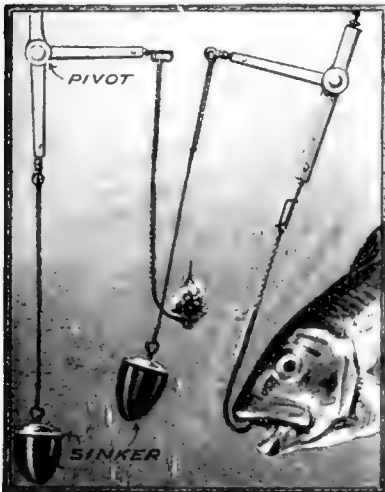

At left, non-fouling connector so constructed that the hook describes a complete circle without fouling the sinker

## A Watch-Like Coin-Case



A novel coin-holder which is made to be carried like an ordinary watch

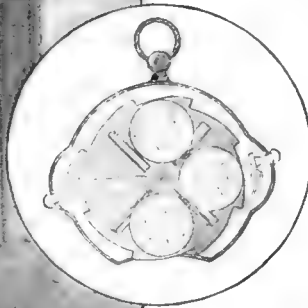

a new one has been invented, which has the shape of a watch so that it may be carried on a chain. It holds eight coins of the same denomination. A central disk, its periphery cut to form eight ratchet-teeth, rotates about a short shaft secured in the watch-like casing. A spring is fastened at one end to the shaft about which it is wound, and at the other end to a pin in the disk. The

disk has eight radial flanges. Four flanges project from one side of the disk and four from the opposite side, alternately.

The casing has two lateral, bulging parts to accommodate two pawls which operate the disk. Each pawl consists of two fingers projecting in opposite directions from a central shaft. The one is held against the ratchet-tooth by a tiny spring, and the other acts as a stop to the adjacent tooth. The shorter one has a finger-button which projects through a slot in the case. On the under side of the outer case is a wide slot for receiving and discharging coins. The coins are alternately inserted one at a time at opposite sides of the disk, this action automatically winding the spring.

## Mosquitoes on Snow Banks

**I**N both the Rocky Mountains and Alaska the geologists and engineers of the United States Geological Survey have as part of their regular equipment mosquito-nets for their heads. Even when working in deep snow, head nets and gauntlets are necessary to protect the field men from the blood-thirstiness of the pests. The mosquito does not vanish with increasing altitude. At eleven thousand feet, or timberline, he is as prolific as at sea-level, and smoke, no matter how dense and pungent it may be, will not eradicate him. The only sure relief lies in the net. In some sections of Colorado the mountain natives let mosquitoes bite them until their systems become thoroughly inoculated with their poison. After this they are bothered no more. The first advice

given to the "tenderfoot" by the old-timer is, "Let 'em bite; they won't keep it up long."



Fighting mosquitoes is a man's job and the mosquito-net is the most effective weapon

**An Improved Vegetable-Slicer**

**A** VEGETABLE-SLICER which can be adjusted to cut anything into tiny shreds, from a carrot to a cabbage, may be described as follows:

An annular base, mounted on feet, has several roller bearings journaled on the inner side of its rim. Resting on this base, and attached to it by clamps, is a cylindrical hopper. A cutting-disk is provided with three or more slots, radially cut, with a corresponding number of blades, which can be adjusted at their edges. There are also a like number of splitter-knives which assist in cutting up the vegetables. When in position in the machine the disk rests on the roller bearings and is rotated by a handle-shaft. Fitting around the vertical shaft is a tube or hub from which radiate four or more partitions, thus dividing the hopper into four or more compartments.

When the vegetables are placed in the hopper the action of the cutting-disk beneath them gradually slices away the whole vegetable, the particles falling through the slots into a dish. Not only

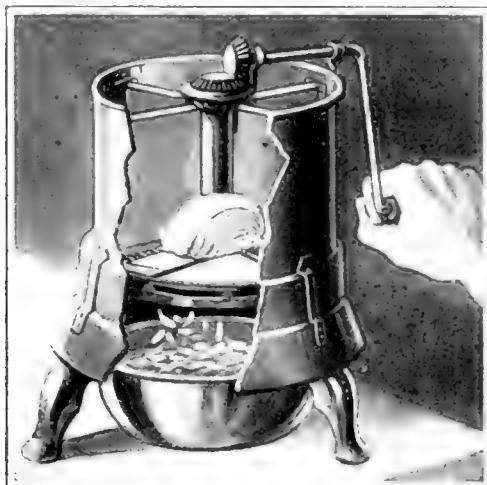

Large and small vegetables can be sliced at one time with this improved device

the size and number of the blades can be adjusted, but the plates which form the chambers are made to fit into grooves on the central hub and inner surface of the hopper, so that they slide in and out very easily. Thus small vegetables, large vegetables or both may be sliced at one time.

**Fish Hatched in Artesian Basin**

**O**NE of the most unique and convenient fish hatcheries of the government is located near Laramie, Wyoming, where sources of good water are few

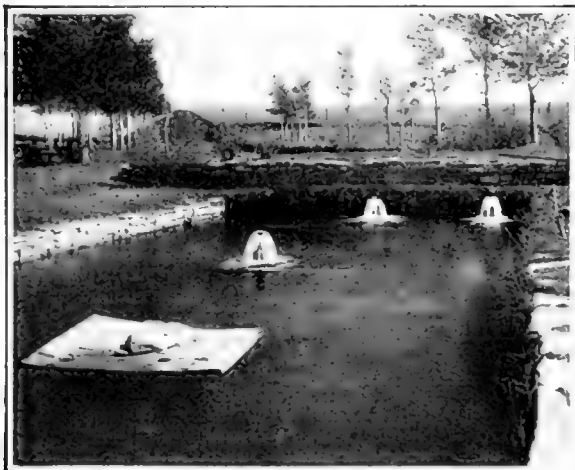

A Wyoming fish hatchery is an artificial pond fed by a never-failing artesian well

and far between, the region being semi-desert. This hatchery is an artificial pond fed by a never-failing artesian well which flows of course night and day. The water comes from a considerable depth and is therefore pure and cool. It is claimed that better results are obtained from raising trout from this hatchery than when ordinary surface water is used. The float in the center of the pond serves as a shady nook in which the young trout can find a cool, shadowed retreat such as this game fish delights in. When the little trout have attained the proper size they are taken out and used to stock the streams in the vicinity. After the water has served its purpose as a trout breeder it flows off through pipes and is used to irrigate the little ranch farmed by the keeper of the hatchery.



# How Indians Graduate from Carlisle

**A** GAYLY decorated platform on which are seated the graduates, faculty, speaker and other invited guests; a lengthy program of music, orations and addresses, probably all cut to order and sugar-coated for the occasion; an award of sheepskins and a benediction—this, in brief, constitutes the stereotyped graduation ceremony of most colleges and schools.

But there is one school which has a different commencement. It is the United States Indian Industrial School at Carlisle, Pennsylvania. Its twelve hundred students are children of America's original people, and the institution is the largest industrial school in the country. Until recently commencement activities followed closely the lines of the average college exercises, with orations and addresses scheduled by instructors in close keeping with the academic part of the school's work.

Today commencement at the Carlisle school is unlike any other. Graduation day is a day of proof as well as showing, for the Indian girl or boy not only tells

what she or he has done, but actually shows how each has succeeded. This event is held in the school's immense gymnasium and audiences of ten thousand people and more from all parts of the United States attend. At the door you are met by a polite Indian usher, spick and span in a school uniform of blue and gold. He finds you a comfortable seat and a program. You look about but see no person in charge of the activities. Over in one end of the gymnasium you hear whispers. Sitting there are several hundred little Indian girls and boys of the short dress and knee-breeches age. The school band of fifty pieces is on a low platform at one end of the room. When the hall is full, a low whistle is heard at the entrance, and then the band breaks into a martial air and into the room troop the upper classes, each headed by its banner carrier. The rear is brought up by the graduates. Presently all have found their places. The platform is yet unoccupied, and there is apparently no leader for the afternoon's event. From



Indian girls are given a thorough course in sewing. At graduation they prove that their knowledge can be applied in a practical manner



A demonstration in plumbing is conducted as part of the graduation exercises. One student explains the proceedings while others do the actual work





The audience is given a concise outline of the work of building a house, a neat model and working-drawings being used for explanation



Housekeeping in all its branches, from the hanging of window-curtains to the upholstering of furniture, is taught at Carlisle

the front row of the audience a clergyman arises, signals the multitude to its feet and a prayer is offered. The band then renders a lively selection, the school superintendent extends a cordial welcome to all, and graduation is on at the Indian's greatest school.

The platform is overhung with a canopy from the carpenter shop, made from lumber and resembling the roof of a porch of a residence. A girl steps to the platform, and curtains near the back of the stage are suddenly drawn. If she is a graduate

in nursing, other nurses step out with two patients and illustrate her talk. If she speaks on housekeeping, such a scene as is pictured is presented to the audience. If she tells how washing in the home should be done, other girls are there to help her illustrate it. If it is dressmaking or millinery, the Indian maiden gives you the theoretical knowledge while assistants supply the practical.

An Indian lad graduates in agriculture. He has his charts of farm lands with plots to illustrate the methods of

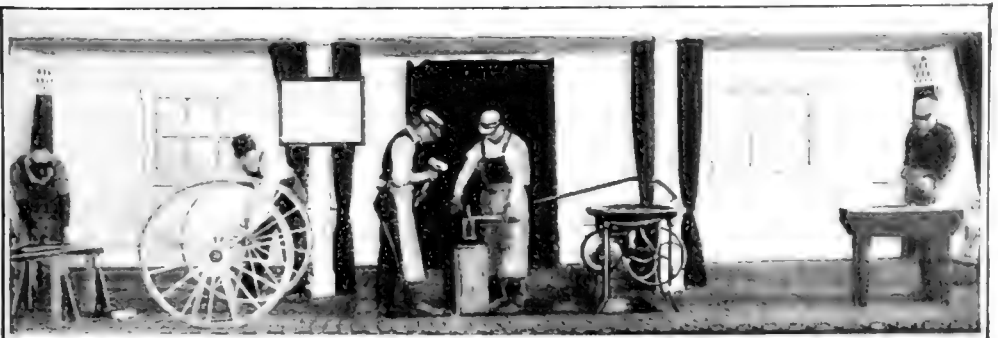

Indian lads are taught blacksmithing. Instead of listening to commencement oratory the spectators at the graduation exercises watch the Indians make horseshoes and weld iron tires

scientific farming. Another boy is a plumber, and while he is telling of his trade helpers are putting together bathroom fixtures and sections of heating plants.

Dairying from beginning to end is described by another boy while pretty Indian milkmaids churn real butter and place it in molds for marketing. How to furnish a home is explained by another lad, while girls help him arrange various pieces of furniture in sectional rooms. Here is a splendid house model and here is a boy telling how it is erected. Helping him are other carpenters and the house shown is completed on the stage so far as the woodwork is concerned, even to placing lath for plastering and erecting the inner staircases.

Blacksmithing is another trade taught at the Carlisle school, and the trade has graduates. Accordingly, a blacksmith shop is placed on the platform. Several pieces of curved iron and wood are

bolted together and wheels fastened to the ends. Running-gears of a carriage are thus made. Another lad grasps the bellows-lever of a forge and soon flames spurt upward. A smithy thrusts real irons into the fire and presently two boys are pounding out red-hot horseshoes on a real anvil. Sparks fly into the air and the ring of the anvil sounds throughout the building. Another lad finishes the shoes at a bench vise.

Government officials are always in attendance at these Carlisle commencements. With school officials they occupy seats until the Indian girl and boy have had their say. Then come the addresses of visitors, presentation of diplomas and the remainder of the program. Such is the way Indians graduate, displaying the academic and vocational education afforded by their training in such manner as to mark the Indian graduation as the most unique and interesting of all commencements the country over.

### Chickens Feed Themselves On The Run

**A**N ingenious citizen of Illinois has invented a contrivance by means of which his chickens feed themselves, thus saving him the trouble of early-rising and feeding them himself. As the man remains in bed his chickens walk around the barnyard and inadvertently step on the ends of a projecting board. The weight of each chicken is sufficient to tilt the board,



The chickens step on a projecting board as they walk around the automatic feeder and this causes the grain to fall from the top

placed in the receptacle at the top of the apparatus the evening before is thrown to the ground. As fast as

the grain falls it is picked up by the chickens and the more chickens there are operating the automatic feeder the faster the grain falls to the ground.

When the first chicken walked on the projecting board and discovered that the faster it walked the faster the grain fell in front of it, other chickens fell in line and it wasn't long before the whole barnyard flock was marching around the con-

trivance, eating up the grain as it fell and working up appetites for the next meal at the same time.

---

Those of us interested in science, engineering, invention form a kind of guild. We should help one another. The editor of *THE POPULAR SCIENCE MONTHLY* is willing to answer questions.

# Housekeeping Made Easy

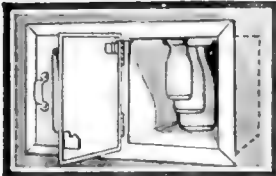

A wall-cabinet refrigerator which holds bottles of three sizes



Handy letter-scale which weighs up to twelve ounces

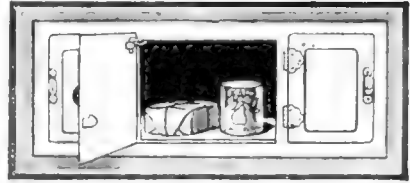

A self-locking steel wall-cabinet with three compartments for perishable goods

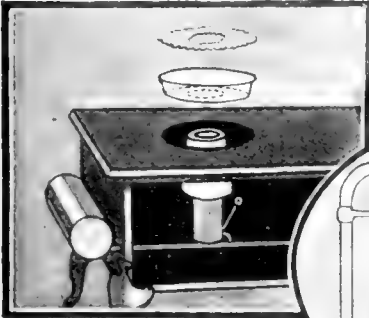

Pie-pan with a hole in the bottom increases heating capacity of the gas-stove burner



Convenient bedside tray or table attached to the bedpost

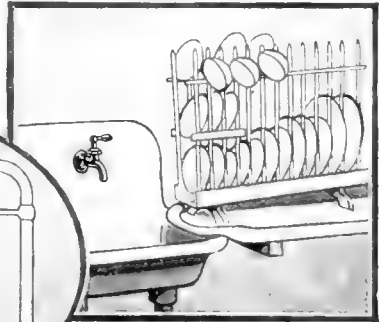

Dish-drying rack of wood which takes the place of the unsanitary dishpan



At right, fork for lifting potatoes without breaking them. At left spoon with knife edge

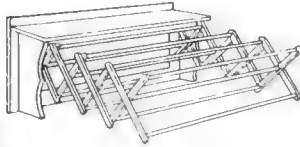

Combination shelf and clothes-drier for the laundry



At right, silver spoon with liquid tube-handle for invalids. At left, diminutive wash-board for cleaning handkerchiefs



Bedroom laundry set with line, two glass-headed nails and six clothes-pins



A round cake-box with handled plate which makes lifting easy



A muffin-pan with six or twelve removable rings to facilitate cleaning

# How to Run a Motor-Boat

**W**HEN starting the motor, close any auxiliary air valves and hold the hand over the air inlet of the carburetor so as to draw in a richer mixture, otherwise the mixture may be too weak to start the motor. If the mixture seems to be rich enough, the engine may start off if a little lubricating oil is let into the cylinder which will make the compression better. Irregular firing usually comes from carburetor and spark troubles. Drain the carburetor and if this does not seem to remedy the trouble investigate the electrical apparatus. Clean the spark-plug and see that the gap is right; the thickness of the thumb nail is a good gage. Too large a spark is apt to be wiry and quickly exhausts the battery. The vibrators of the coils should not be set too loosely in the hopes of saving current, but should be set to produce a sharp, clear spark. They do not need to be too tight.

When a two-cycle motor fourcycles, that is, fires on every other revolution, the gas is too rich and should be cut down at the needle-valve until an even cycle takes hold. Weak explosions and backfires through the carburetor indicate

that the mixture is too weak and should be increased. If an engine runs steadily but seems weak the trouble may be in loss of compression, poor lubrication, poor design, or parts out of alinement, carbon or clogged outlets and gas passages. Sudden stopping is usually due to a broken electrical connection; while slowing up and stopping is caused by lack of gasoline or clogged feed line; engine too hot or poor lubrication. Overheating of the engine is usually caused by a lack of lubrication or poor circulation of cooling water. The pump should be examined and if working badly should be repacked and oiled.

Boating is about the only sport or business in which there is so much courtesy. A helping hand is always given if need be and you always seem to be expected to salute any passing boat.

When steering in a fog without a compass it is nearly impossible to maintain a straight course. Take a long line with a float tied to one end and let it drag over the stern. The line will drag directly behind when you are steering a straight course and will swing sideways when the boat swings away.

## Prize Winners of Sam Loyd's Puzzles

### For April

The honor prize of \$5 is awarded to:

John J. Furia, Hamilton Hall, Columbia University, New York City.

The ten \$1 prizes are awarded to the following solvers:

Edward Hillery, Sherrard, Ill.  
W. H. Fitzgerald, 87 6th Street, Pelham, N. Y.  
A. M. Stimpson, 163 Hemenway Street, Boston, Mass.  
William S. La Londe, Jr., 1354 Asbury Avenue, Evanston, Ill.  
R. T. Huntley, 1136 Center Street, Newton Centre, Mass.  
A. Prescott Barker, 13 Arlington Street, Lynn, Mass.  
Fred A. Tracey, 37 White Street, Mt. Holly, N. J.  
L. M. Merrill, Glendale, Ohio.  
Edward Norton, 26 Grove Street, Rockland, Me.  
Francis E. Stanley, Newton, Mass.

### For May

The honor prize of \$5 is awarded to:

L. F. Woodruff, 22 Cherry Street, Atlanta, Ga.

The ten \$1 prizes are awarded to the following solvers:

Fred. Ausehertz, Oak Lawn, Ill.  
Harry Pence, 2723 Euclid Avenue, Cincinnati, Ohio.  
S. V. Halsey, Lee, Mass.  
Homer Calkins, Dallas, Oregon.  
E. Elwert, Route 2, Conshohocken, Pa.  
Frederick G. Dilger, Overlook Hospital, Summit, N. J.  
Charles W. Zaring, Hay Island, Gananoque, Ontario, Canada.  
August Kuehn, 726 Proctor Street, Port Arthur, Texas.  
Wallace C. Harding, Randolph, Mass.  
O. E. Cote, 184 Harrison Street, Pawtucket, R. I.

# Little Inventions to Make Life Easy

## Why Weren't They Thought of Before?

### A New Way of Directing the Breeze of a Fan

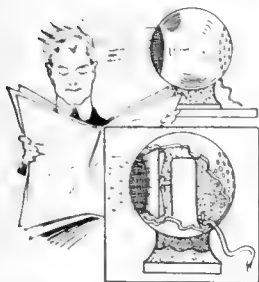

A FAN motor is enclosed in a spherical shell, so that no moving parts are visible. The current of air generated by the fan is directed through a nozzle which is covered by a wire mesh as a protective measure. The air is forced out in a parallel current, and blown in any desired direction.

### Handling the Cord of Electric Irons



THE convenience and usefulness of electric flatirons is sometimes impaired because of the connecting cord's continually catching on the end of the ironing-board or other obstruction. An arm-band has lately been invented which will hold the cord close to the operator's elbow, and thus make it follow all motions of the arm naturally. This not only conserves the temper of the user but saves wear on the cord.

### A Salt-Shaker Which Will Not Clog



A CLEVERLY devised shaker has been made, the makers of which claim that it will loosen clogged salt. It is of clear glass with a non-corrosive white metal top. A spiral loop of wire which occupies the center of the shaker, is turned by a twist of the knob above the lid. The coil of wire when turned reaches every part of the interior of the shaker, thus breaking up the salt.

### At Last! A Lock For Slipping Rubbers

#### RUBBERS

R and overshoes are apt to slip from the foot and stick in the mud when a little worn—as every commuter who has hurried to catch a car knows. A new device has been brought out, which consists of a hook-like member riveted to the rubber and a socket attached to the shoe, both being made of metal. The hook catches in the socket and holds the rubber shoe securely until it is removed by hand.

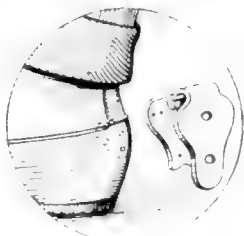

### Adjustable Kettle-Cover

AN adjustable kettle-cover of a conical shape with a handle at the side is so made that by a slight pressure on the handle and a simple adjustment, the cover

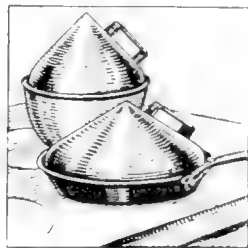

fits any ordinary pot or pan. The conical shape allows steam to gather in the top; this not only prevents boiling over but also serves to cook the food more thoroughly. The volume of steam held within the dish hastens the cooking process.

### Hammer for One-Armed Man

THE illustration shows a hammer which is very useful to the one-armed man. With it he can set nails as well as if he had both arms. The hammer is also very useful to the normal person. It adds some two feet to any carpenter's reach.



## Semaphore Signals for Automobiles

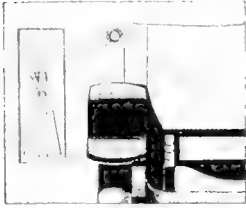

**T**HE illustration shows how an automobile driver may convey his intentions to the occupants of a car in the rear, by means of a semaphore signaling device. It will be noticed that the two semaphores are mounted on the rear mudguards of the car; and by means of an electromagnet concealed in each column the signals can be controlled from the driver's seat. If the automobile is to stop, both semaphores will be thrown up; if a turn to the right is intended, the right semaphore arm will be displayed. For night use electric lights are provided in the signal columns, and by means of red and green glass disks in the semaphores the desired signals may be easily displayed.

## Combined Penholder and Blotter

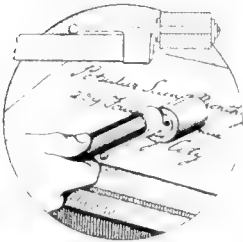

**A** NUMBER of disks made of blotting paper are held on two small washers which are fastened to the ends of a central axis. This device is attached to a penholder by means of a clip similar to those commonly used to hold a pen or pencil in the pocket. In use, the blotter is rolled over the writing, instead of being placed flat.

## Saw Cuts Square Hole

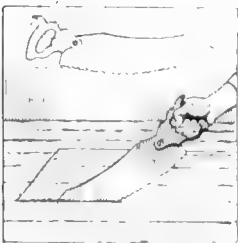

**A** SAW that cuts a square hole in a floor without the aid of any other tool is shown in the illustration. The saw is rounded so as to make the incision and provided with an adjustable handle so that the strain on the wrist in the initial stages is eliminated. An auger bit is not needed.

## An Adjustable Golf-Tee Board

**A** GOLF-TEE board which provides three tees at different elevations above the board has been invented to meet the ideas of individual players. On a disk revolving in a vertical slot or opening of the board the three tees are attached and project varying distances from the axis of rotation so that the balls may be supported at different elevations above the board.

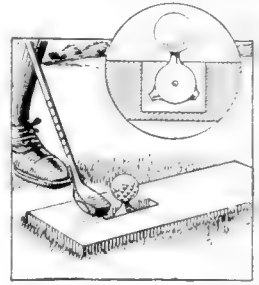

When the ball is driven from either one of the individual tees the tee as a whole will yield and turn in the direction of the blow, thus reducing the possibility of injury to the tee and permitting an unretarded release of the ball.

## Skinning the Slippery Eel

**T** HIS clamp-like tool grasps the skin of an eel, tweezer-fashion, and strips it off in much the same way as one removes a glove. Special notches enable the jaws to grip the skin securely. The opposite end of the tool is a knife-blade useful in further dissection. Projections on the back of the blade are handy in scaling fish.

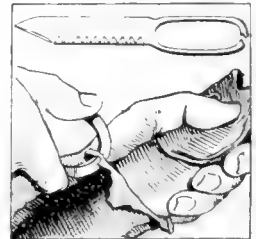

## Why Fall Down in Your Bath-Tub?

**P**ERFORATIONS are made in the bathtub rim to serve as handholds, the holes being cut in a variety of forms as shown. A firm grip can be secured on these even though the hands be slippery with soap. Thus the slips and slides frequently resulting from an insecure handhold are avoided.

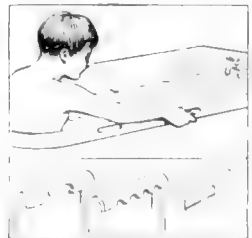

# Camp Fire Maxims

By H. S. Rinker

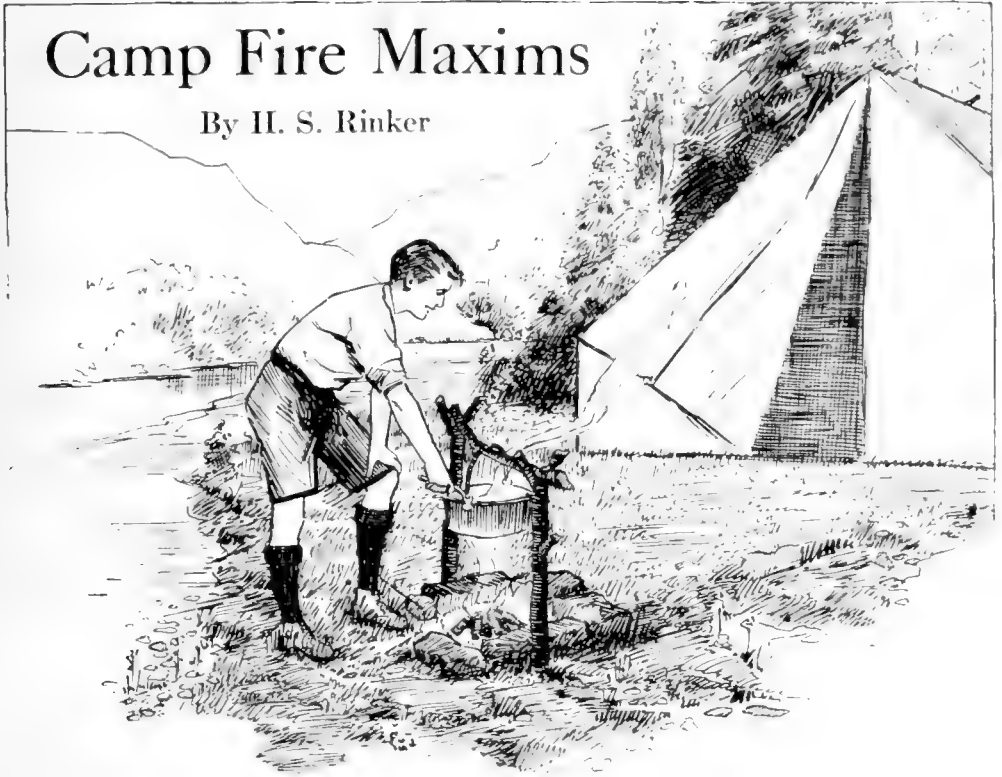

To build a fire, whittle a stick, leaving the shavings projecting on its sides. Push into the ground and build up small sticks around it; then ignite

**C**LEAR a place for the fire, so that it cannot spread. One of the best ways is to dig a ring around it, so that damp earth interrupts the dry grass or dead leaves which may be present.

See that the flame will not scorch trees. Never throw away a match—not even a burnt one or a wet one. When you have used a match, pinch out the glow with your fingers, and *stick it into the ground*, burnt end down. Millions of dollars have gone up in smoke for lack of this simple precaution.

If a match is wet, rub the match head through your hair for a few seconds, and it will almost invariably light when struck. Keep matches in a metal box, with a water-proof lid.

Remember that birch-bark or dry pine-needles are fine kindling.

Remember that a small lens will start a big fire if the sun is shining.

To start a fire in dry weather, whittle a dry stick so that the shavings

stand out at an angle, but do not cut them off. Stick this kindling in the ground. Build up, tepee fashion, other small dry sticks around it. Put some dry pine-needles, birch-bark, or paper at the base of the stick, and touch it off. It starts quickly.

## *To Start a Fire in Wet Weather*

Locate a sheltered spot. If that is not possible, find an old log, a flat stone or a decayed stump. Roll the log half over. This exposes the dry side. Build your fire against this or against a flat stone, propping up one edge and building the fire under it. Or gouge out a rotten stump and build the fire in the cavity.

The powder from a cartridge cut open and emptied will help, especially if slightly dampened.

*Always stamp out, drown out, or bury your fire before leaving camp. Never forget to do this.*



A match is not necessary for starting a fire if a lens is at hand to focus the sun's rays on the fuel and ignite it

#### To Carry Fire on a Boat

Put it into a bucket with sand or earth in the bottom. Always try to use live coals or embers for this purpose. They will hold for a long time if covered skilfully with damp moss.

#### To Build a Fireplace for a Semi-Permanent Camp

Set a flat stone on edge for the back. The sides are two flat stones about 6 ins. thick. The front is open. Dig a small pit about 6 ins. deep between the stones. This will soon fill with ashes. Don't remove them. They are fine for roasting corn, potatoes, fish, etc. The stones make a curb which adds much to the draft of the fire. The side stones get hot. These serve to put the coffee pot on after it is boiled. Boil it seven minutes. Then set it on the hot stone till wanted. If you want to roast corn, strip it down, remove the



Fire is prevented from spreading by a simple trench dug around it

silk, pull back the husks and put it under the edge of one of the stones. Pull the hot ashes over it. Treat potatoes the same way.

#### To Bake Fish

Clean them, season, wrap them with corn-husks, wild-grape leaves, or sassafras leaves, cover with moist clay and bury in the ashes.

Venison and all kinds of meat other than bacon or cured ham can be kept from flies by hanging eight to ten feet above the ground in flour sacks. Never wrap cloth around fresh meat; it serves to hasten decay. Venison should not be washed unless it comes in contact with dirt; washing destroys its delicate flavor.

#### Using Gates to Lessen Danger from Truck-Trailers

THE rapidly increasing use of motor-trucks as tractors for hauling trailers of various kinds has resulted in the development of protective devices to

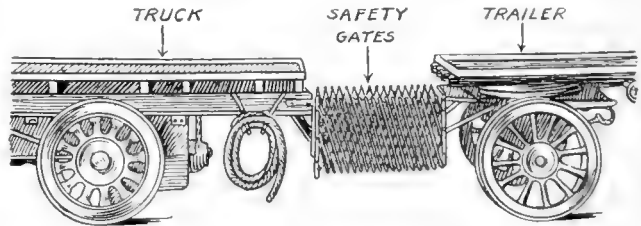

Many accidents might have been avoided by the use of this arrangement

prevent the injury of thoughtless pedestrians who unwittingly run in between a truck and trailer, when endeavoring to cross a street, thinking that they are separately propelled vehicles running close together. An English safety-gate arrangement is here illustrated. The gates are built on the lazy-tongs principle so that they can close up or extend as the trailer rounds a curve. They are securely attached to triangular supporting frames, fastened to the rear end of the truck frame and the front of the trailer, as indicated.

They are constructed in various sizes to span the smallest and the largest distance between a truck and a trailer. In some instances they have taken the place of the customary danger flag which is often unnoticed.—VICTOR PAGÉ.



# For Practical Workers



## How to Make an Efficient Boiler-Patch

THE usual method of patching a boiler cannot be relied upon for high efficiency. Suppose there is need of a patch at the check-valve hole of a locomotive-boiler.

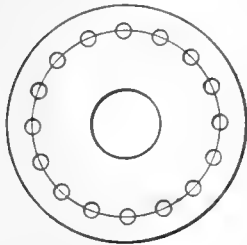

Fig. 1. The usual form of boiler-patch

The radial cracks, most often along the length of the plate, start out from the hole. If a disk of boiler-plate is applied with a single row of rivets, as shown in Fig. 1, there is danger of tearing the boiler-plate or the patch, between the rivets; also of shearing the rivets.

The more rivets are used, the weaker the patch, since every hole weakens the plate. This may be seen by examining Fig. 2. The first piece of cardboard is solid all the way across; the second has a hole in it, making the resistance to tearing just that much less. The only way

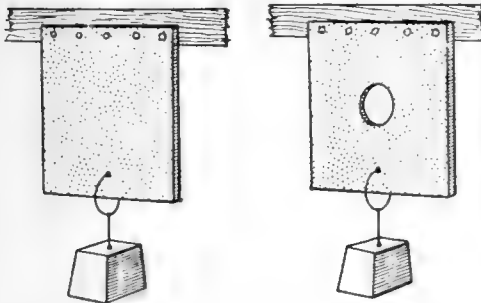

Fig. 2. Obviously the hole in the plate shown at the right weakens it

to prevent shearing the rivets is to add more rivets opposite the defect, but this increases the number of holes and actually weakens the plate.

This difficulty can be avoided by the use of a patch like the one shown in Fig. 3. Two rows of rivets are used. The additional number of holes does not weaken the patch, however, because the force tending to pull the plate apart does not act at right angles to the line of

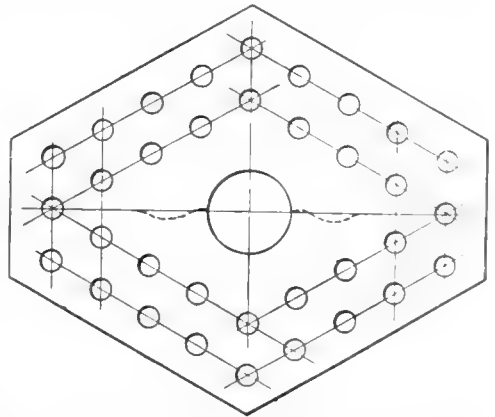

Fig. 3. An improved patch can be made by placing the rivets so as to prevent the strain from acting at right angles to them

rivets. The component of this force is to be reckoned with and the greater the angle of the rivets the less this force will be. By multiplying the number of rivets it is possible to mass more metal opposite the defect than there would be in the original plate, and the efficiency in shearing will be even greater than one hundred per cent. The observance of this simple expedient, which simply takes into consideration a principle of physics, will result in far less danger from weak spots in a boiler.

## An Easily Made Mercurial Barometer

THE accompanying diagram, Fig. 1, shows a useful barometer of simple construction. The baseboard *A* may be of mahogany, 38 ins. long, 2½ ins. wide in the central part and ¼ ins. at the ends. A straight glass tube *B* is needed, 36 ins. long and about ¼ in. in bore. After filling by the simple method about to be described, it may be fastened to the center of the board by means of

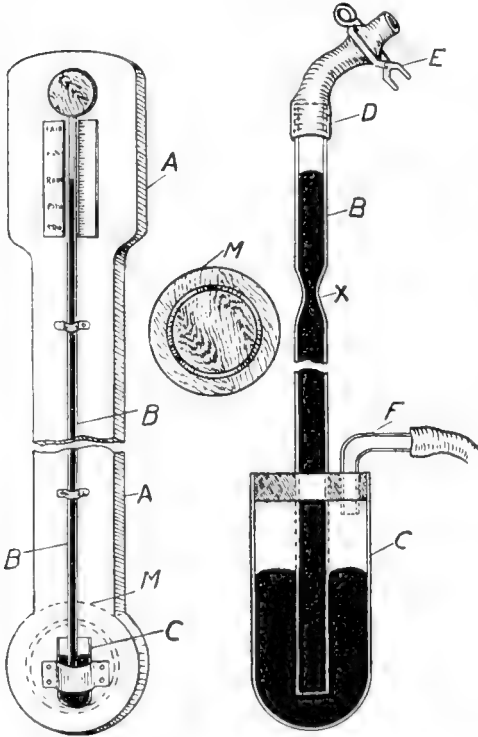

Fig. 1

A mahogany base, a glass tube and a mercury cistern comprise this barometer

experience the principal difficulty, owing to the necessity for excluding air. The regulation method is fairly easy in experienced hands, but the following will be found much simpler. The tube *B*, Fig. 2, is of soft glass with walls of medium thickness. It is therefore a simple matter to make a constriction at *X*, 3 ins. from one end, by softening the tube in the flame of an alcohol lamp and drawing the ends gently apart. To the open end above the constriction should be attached a short length of India rubber tube *D*, capable of being closed with a brass clip or pinchcock *E*. The other end of the tube should be passed through an India rubber cork, fitting tightly into a wide glass tube *C*, forming the cistern. A bent tube *F*, previously passed through the cork towards the side, serves for connection with a cycle-pump and valve, with thick-walled rubber tube.

Let the tube be supported vertically, the cistern being rather more than half filled with mercury—before inserting the cork, of course—and force a little air in with the pump so as to drive mercury into the tube to about two-thirds of its length. Without removing the cycle-valve attached to *F*, that is, without letting any air escape, lower the tube gradually in a slanting direction. The mercury will rise still higher until it passes the constriction and fills the India rubber tube. Then close the pinchcock, remove the valve from *F*, and replace in the vertical position. The mercury will come to rest somewhere near the end of the tube, as shown in Fig. 2. The space above it is a vacuum since the air has been driven out and prevented from re-entering. The upper end of the tube above the constriction is no longer required and may be removed by directing the alcohol lamp flame against the narrowest portion with a mouth blowpipe, (or even an odd piece of thin tube), the same operation serving to close the top of the barometer tube with a neat and perfectly airtight seal.

neat brass saddles. The cistern *C*, to be described in connection with the method of filling, is provided with a wider saddle at the lower end of the board. This may be hidden, for the sake of appearance, by means of the polished mahogany disk *M*. The appearance will be improved by turning the disk, or providing a small beveled mirror in the center. The upper end of the tube may also be concealed by means of an ornamental disk of turned wood.

It is in filling the tube with mercury that most amateur barometer makers

A scale of inches and tenths must be made on glazed cardboard or imitation ivory and attached to the top of the board, a similar scale being fixed on the other side of the tube to show the words

"rain," "fair," etc., if required. It is presumed that reference can be made to a standard barometer for the purpose of determining the points of the scale. Two comparisons should be made on different occasions, once when the standard instrument is very low, and once when it gives a high reading. Say the two readings are 27 and 31 ins. respectively. Then the distance between the two corresponding positions on the home-made barometer may be provisionally divided into 40 equal portions and called tenths of an inch, the figures being marked to correspond. But an effort should be made to check as many of these intermediate positions as possible by comparison with the standard instrument.—H. J. GRAY.

#### Killing Vermin with Gas

**H**YDROCYANIC-ACID gas is one of the most efficacious agents in ridding households of such pests as bedbugs, fleas, cockroaches, ants, clothes-moths, etc. Rats and mice, when exposed to its fumes, run out of their holes into the open and die there. There is thus no subsequent annoyance from dead rodents in the walls and under flooring.

Even when only one room of a house is to be fumigated the entire house must be vacated and so closed and marked with signs that everyone is kept out. The windows in such a house must be equipped with ropes so that they can be opened from the outside when the fumigation is done. If the house is close to another, especially if its windows are below those in an adjoining house, care must be taken to protect neighbors. This is especially necessary in the case of a house in a row, particularly if the partitions separating houses are not tight, or if its attic or roof air-space communicates with those in the neighboring houses. For these reasons, in the case of summer cottages at beaches, it is safest and easiest to fumigate before the family or neighbors have moved in, when there is plenty of time to air the house completely after it has been treated.

While hydrocyanic-acid gas is probably the most efficient means of ridding a house of vermin, it is also one of the most deadly poisons. Therefore, the greatest care should be exercised in its use.

#### A Wallpaper Remover

**T**HE difficulty and inconvenience incident to the removing of old wallpaper and the preparation of the wall for redecoration are reduced to a minimum by the use of a new tool that gets at the root of the trouble. It works under the paper, or, rather between the paper and the wall, softens up the paste or glue and freely strips the paper from the wall.



Every bit of wallpaper should be removed before beginning the work of repapering

It is particularly adaptable where there are several layers of paper to be removed, or for stripping off extra heavy or varnished paper. The usual way of flooding the walls with water or filling the room with steam are not necessary. The simple mechanical device illustrated generates steam on the spot with a gasoline burner and the steam is controlled by a valve in the hand-piece where it is driven behind the paper in a thin sheet.

## A Non-Spillable Funnel



**A** FUNNEL which will cease flowing automatically when the vessel into which the liquid is being poured reaches a certain height, can be devised by attaching a metal float to the tapering funnel-tip. The float is a small metal cylinder closed at both ends. Small brass tubes should be soldered on opposite sides of the float, as indicated in the drawing. Nails which will fit loosely in the tubes should be soldered at their points to the tip

of the funnel, with the float in place.

When liquid is poured into the funnel, it will flow past the float until the vessel is nearly filled, whereupon the float will rise and check the funnel's discharge. The funnel can then be withdrawn quickly, so that little or no liquid is lost.

It is also advisable to use a funnel with a widely diverging rim to take care of the overflow. When the float is suddenly pushed up against the spout the liquid begins to rise in the funnel, making this necessary.

## A Dark-Room Lamp

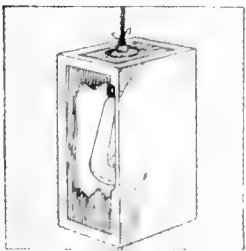

**A** VERY handy dark-room lamp can be made from a cigar box. After tearing off the cover, cut a hole in one end just large enough to allow it to be slipped over an electric light bulb

and porcelain receptacle. Paste ruby paper over the opening. A fifteen-watt lamp will not be too bright.

When the room is to be darkened, this is put over the light. When not it is simply left off. With this, one can get along with one light in the developing-room.

## A Handy One-Drop Oiler

**A** VERY useful oiler made from materials to be found in nearly every box of odds and ends is here shown.

The oil container is a dust cap from an old automobile tube. A  $\frac{1}{2}$ -in. plug is cut from an old valve-stem and a washer fitting this plug is soldered to it at the center. A six-penny nail which will fit the hole in the plug is soldered in place and flattened at one end. A leather washer should be made for the plug and the oiler is ready for use. This oiler will be found handy around the house as well as in the garage.—F. W. NUNENMACHER.

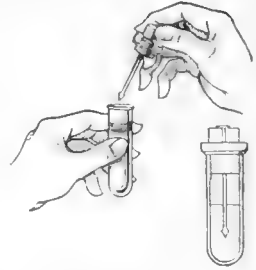

## Rubbing in the Lathe

**T**HE writer had a number of pieces of cast-iron to be filled with machine filler after which they were to be rubbed smooth and flat. Rubbing by hand was slow and the surfaces hard to flatten.

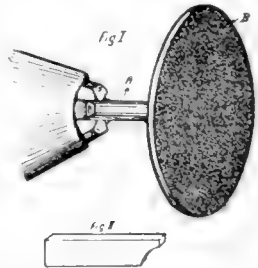

The cut shows the fixture used for rubbing; it worked very successfully. The shank *A* Fig. 1, is held in the chuck of the lathe and the face *B*, turned flat. To the face *B*, a piece of coarse emery cloth is glued and the "rubber" revolved at a fairly high speed. The work is held by hand against the revolving "rubber" until the desired results have been obtained, after which they are finished by hand, rubbing with fine emery cloth.

After the emery cloth has been glued to the "rubber," it should be placed face downward on some flat surface and weighted down. The kind of work for which this fixture was used is shown in Fig. 2.

The bed of the lathe should be covered to keep the emery away from the bearing-surfaces.—C. ANDERSON.

**An All-Steel Screwdriver**

**T**HE screwdriver to be described is constructed entirely of steel and while feeling heavy at first will be found to be very well balanced and able to stand hard usage. If the blade is broken it can be easily repaired or replaced or different sized blades may be used.

The whole tool, including the fluting of the handle, was made on a small back-gear lathe with a hand-fed carriage.

A 5" length of 1½" cold-rolled steel shaft was cut off and a 3/8" hole deep bored in the center of it to take the blade. The handle was then roughed out nearly to the finished dimensions and a light finishing cut taken all over it at high speed.

The handle was fluted as follows: The circumference of the large end was

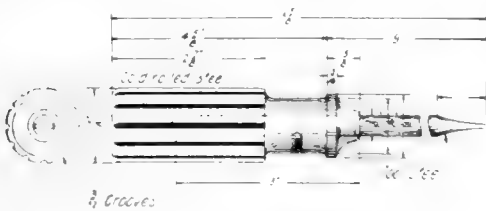

A screwdriver made entirely of steel

divided and punch-marked into twelve equal parts. Then a hole was drilled and tapped for a 1/4" set-screw in the small part of the handle, as shown in the drawing, and a length of 3/8" rod set in and countersunk for the set-screw. The outside end of this rod was held in the lathe-chuck, the large end of the handle being held in the back-center. A steel lathe-tool with a small rounded end, was placed in the tool-post turned over on its side; the lathe-chuck was kept from turning by locking the back-gears, and then each groove was cut by moving the carriage along by hand and taking a succession of light cuts until the groove was of the required depth.

The blade was made of a piece of 3/8" tool steel with the tip end hardened and was held in the handle by means of the 1/4" set-screw, countersunk about 1/8". A set of blades could be made of different lengths or with tips of different widths.

**A Buck-Saw Attachment**

**T**HE ordinary buck-saw frame has a tendency to cramp the upper hand when sawing. To eliminate this, bore a 3/4 in. hole through the top part of the frame just

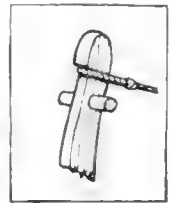

A simple peg makes the task of sawing wood a little less strenuous

below the tightening wire. Cut off a piece of an old broom handle 4 ins. long and drive it through this hole half projecting on each side. By gripping this pin with two fingers on one side and two other fingers on the other side, with the saw frame between, the wrist will not be twisted.—W. J. ALBIN.

**How to Etch Glass**

**W**ARM a piece of glass carefully; if heated too rapidly the glass will crack. Rub paraffin or beeswax over the warm surface of the glass. With a blunt instrument print the desired wording.



The fluoride bath

Place in some fluorspar (calcium fluoride) in a metal dish, add enough concentrated sulphuric acid to moisten the powder. Place the glass, with the marked side down, over the metal dish containing the above chemicals and leave it over night. In the morning, scrape the paraffin off and the desired words will be etched on the glass.

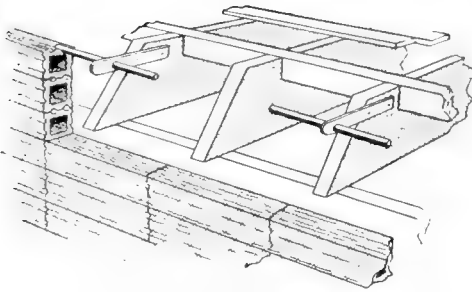

A clever way of bonding joists

**Bonding Joists to Brick Walls**

THE illustration shows how it is best to bond joists to hollow tile walls in the building of residences. A piece of  $\frac{1}{4}$ -in. by 2-in. strap-iron is spiked to the joists as shown. The outward end has a hole bored through it and holds a  $\frac{1}{2}$ -in. steel rod that is 10 ins. long. This rod fits into a groove in the top side of the tile in the mortar joint.

This scheme makes a solid connection between the floor joists and the hollow tile walls.—W. E. FRUDDEN.

**Emergency Control of Motor**

A METHOD is herewith illustrated for stopping a motor at will from any part of the shop. When the push-button is pressed the circuit is open and the lever will fly back, stopping the motor. A number of these buttons connected in series may be used, one by each machine. Should anything happen to the operator the button could be pressed and the motor brought to a stop at once. In the construction of the push-button a spring keeps the disk in contact.—FRANK HARAZIM.

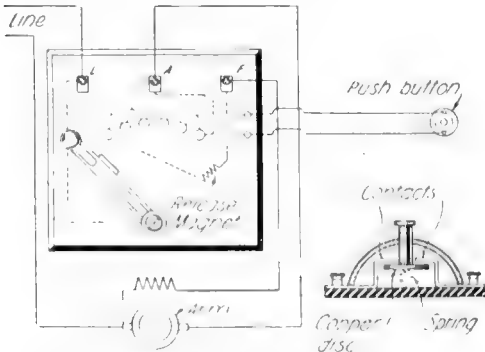

Diagram of device for stopping motor from any part of shop

**A Drainage Kink**

IN the installation of an 8-in. steam line, using present headers and steam openings in a steel and brick building used for gas-making purposes, it was found that to place the line with least expense and to drain back to the boilers, a 12-in. I-beam was in direct line.

To go over or under the I-beam meant a trapped line and use of a steam trap. To avoid the use of a steam trap and take care of condensation the connection was made as shown below.

An 8-in. line was installed using 45-degree bends over the I-Beam and a two-inch drain line underneath the I-Beam. The two-inch line takes care of condensation and gives drainage back to the 8-in. line which in turn drains to boilers.—W. W. FLANDERS.

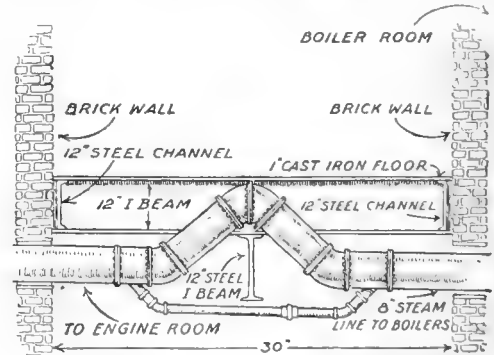

Ingenious arrangement of drainage pipes around an I-beam

**A Screwdriver Handle**

A SPLIT screwdriver handle may be neatly repaired by means of wire and solder. Place the end of the split handle in the lathe chuck. The jaws will force the split parts into nearly their original position. Make a slot around the handle wide enough to take four or five turns of wire and deep enough so the wire will be below the surface. If a lathe is not available, the handle may be held in a vise and the slot cut with a knife.

With a hand drill, make a hole near the slot in which to start the wire. The hole should be as nearly the size of the wire as possible. Wind the wire on tightly. Holding the end with pliers, cover the wire with solder, forming a solid metal band. Smooth the solder with a file, and the screwdriver is as good as new.—B. H. LIBBY.

# Automobile Shop Repairs

## Replacing Automobile Piston-Rings

WHEN replacing the piston in the cylinder of a gasoline engine, after it has been taken apart, it is usually difficult to get the compression-rings to enter the bore because they have to be sprung shut one at a time in order to slide in. A new device has been designed to obviate this difficulty. It is formed of two flexible steel cables connected by a series of steel bars, the last bar on one end and several bars on the other end being fitted with lugs.

The method of using the device is to wrap it around the rings of the piston, after which a small clamp is placed on the proper lugs and screwed up until the rings have closed tightly around the piston. When the piston is slipped into the cylinder the contrivance is pushed off the rings as they enter the cylinder in succession.—E. G. INGRAM.

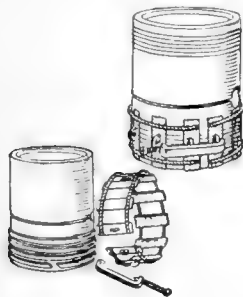

The difficulty of replacing the piston in the cylinder of a gasoline engine can be facilitated by means of a series of steel bars which are arranged as shown

## Steam as a Carbon Remover

FOR a number of years certain tractor manufacturers have been able to use kerosene as a fuel by injecting a small amount of water in it. The water flashed into steam from the heat of the explosion and reduced carbon deposits that would otherwise form in the combustion chamber. A small steam vaporizer has been devised recently for use with gasoline automobile engines which makes the admission of steam into the firing-chamber an automatic process. The device is shown in accompanying-illustration. The water-container *A* carries a float *B* and a float-regulated-water-admission valve *C*, and is designed to be clamped around the exhaust-manifold. The cover con-

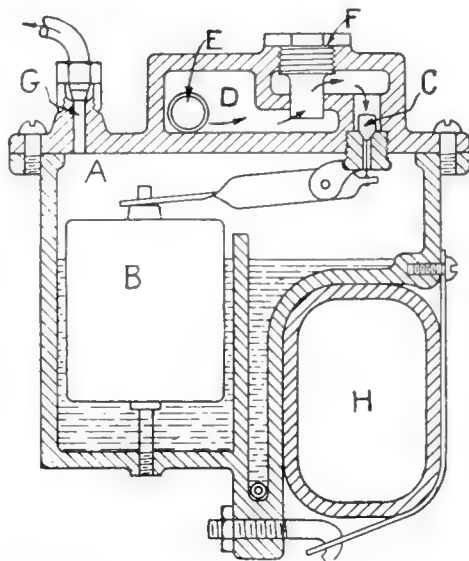

Steam vaporizer for reducing carbon deposits in combustion chamber

tains a chamber *D* into which water passes through hole *E* from the water-jacket around the cylinder-head. Hole *E* is connected with the water jacket by a pipe and unions. There is sufficient pressure due to head of water in the radiator to force the water through the pipe to *E*, then up through the filter to the orifice controlled by the float-valve *C*. The steam generated in chamber *A* by the heat of the exhaust-pipe is drawn out through pipe *G*, which communicates with the induction pipe above the carburetor.

A certain quantity of steam or water vapor is mixed with each ingoing charge and the engine not only develops more power, owing to an increase of the mean effective pressure of the explosion, but the oxygen gas liberated by the breaking up of the steam keeps the engine clean by combining with excess unconsumed carbon. It is doubtful whether the small amount of steam drawn into the mixture can make any appreciable difference with the power developed, but it is a known fact that introducing water vapor in proper quantities will tend to reduce liability of carbon deposit in the combustion chamber.—VICTOR W. PAGÉ.





that of the cylinder before it is expanded by the clamping-nut. It is turned to have a very smooth surface. In use, the drill-press is set in the back gears so the spindle will rotate slowly, while the lap is revolving. It is also raised up and down by the hand-feed lever. The lap may be expanded slightly after it has been turned and reciprocated for a time and fresh abrasive added. Care should be taken to clean all emery and oil out of the cylinder when the lapping process is completed. If the work is properly done, all the scratches will be eliminated and a smooth bore secured. Deep scratches, such as caused by a loose wristpin, can only be eliminated by re-boring the cylinder.—VICTOR W. PAGE.

**A Handy Hook for the Automobilist**

**A** HANDY and cheap attachment for an automobile-jack is an iron hook that can be made by any blacksmith. It should be just a little shorter than the jack, with one end bent to fit over the top of the lifting head and the other end formed into a hook large enough to hold an axle, and strong enough to lift the car. In this way, the machine can be easily raised in places where it is impossible to set up the jack in the usual manner, for lack of clearance. The hook will be found particularly valuable when the automobile gets stuck in the mud and there is no pry available. In this situation there is never sufficient clearance to use the jack, but with the hook, the car can be raised far enough to get a board, a box or some dry dirt under it.—E. F. AYERS.

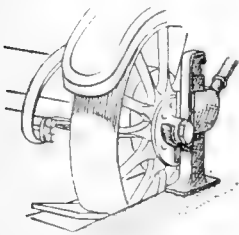

A useful hook

**Simple Cure for Misfiring at Low Engine Speeds**

**T**HE writer recently cured a case of misfiring at low engine speeds by a very simple expedient. The engine was a comparatively new one, and had not been run long enough to ascribe the trouble to wear in the inlet valve stem-guides. All manifold joints were tight,

and there was no air leak around valve-caps or petcocks. The carburetor adjustment was altered without receiving any benefit. A good spark was obtained from both battery and magneto systems, and as the misfiring was as pronounced with one ignition system as

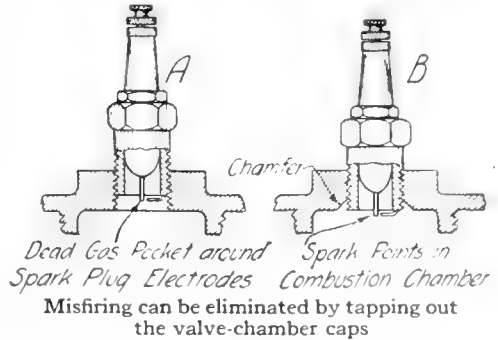

the other, it plainly was not the fault of the ignition group. The misfiring was not serious but annoying, especially when running the engine slowly on the direct-drive in traffic.

In removing the spark-plugs to experiment with various gaps between the electrodes, it was noticed that the plugs did not screw into the cap very deep and that there was a pocket in the valve-cap beneath the spark-plug, as shown at A in the accompanying illustration. As everything else had been tried without curing the trouble, the valve-chamber caps were tapped out with a 1/2-in. pipe tap so the plugs could be screwed in enough to eliminate the pocket entirely as shown at B, and the edges of the tapped holes were chamfered to make sure the plug would project into the large chamber in the valve-cap. After the parts had been replaced, and the carburetor restored to its original condition, all misfiring ceased.

The explanation is that at low speeds, owing to imperfect scavenging and low rate of inlet gas flow, some dead gas left from a previous explosion collected in the small pocket around the plug-points; when the spark took place, the ignition function was erratic because of the poor gaseous mixture surrounding the plug-electrodes. Bringing the points further into the combustion chamber eliminated this condition, because the electrodes were swept by the fresh gas at every intake-stroke.—VICTOR W. PAGE.

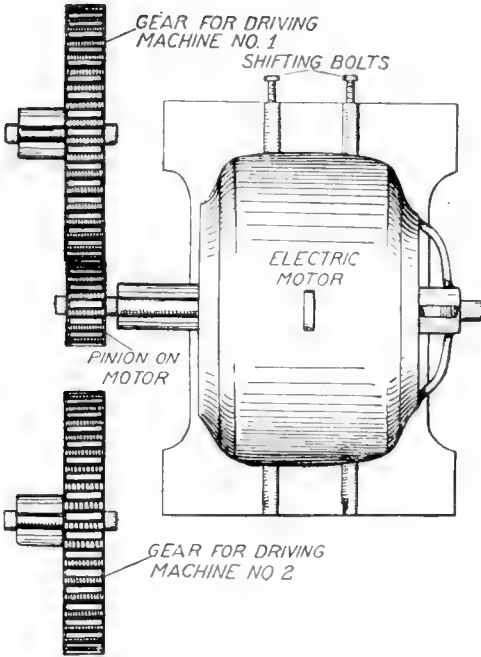

Plan of motor serving two drives. Turning a bolt makes the shift

One Geared Motor Serves Two Drives

THIS diagram illustrates a good method for making one geared motor serve two drives. Line up the two large gear-wheels No. 1 and No. 2, as shown in the diagram. Set the motor so that the motor-pinion falls between them. It must not engage both large gear-wheels at once. As shown here, the motor is driving machine No. 1. By simply turning the shifting-bolts (usually there is only one shifting-bolt on a motor), the power is quickly applied to gear-wheel No. 2 for driving machine No. 2.—N. G. NEAR.

A Pocket-Clip for Pencils

A CLIP for holding pencils and fountain-pens in the pocket can be made from a paper-fastener. One end of the fastener is straightened and wound tightly about the pen or pencil, while the other end lies flat in a lengthwise position.



A pencil clip is about the cheapest thing in the world to make

Building an Oil Reservoir

A SIMPLE and useful outfit for the storage of oil or other liquids is shown in the illustration. A one-hundred-gallon range-boiler is shown at C; 1 1/4-inch air-pipe is connected to the simple pump shown and to the top of the tank (the unions A and B are of the ground-faced kind so that the pipes can be disconnected and laid aside when not in use). The oil barrel G is rolled into place and blocked with pieces H and H<sup>1</sup>, the bung removed and the one-inch pipe connected as shown. The valve E is closed, of course. By working the hand-pump the air will be removed and the oil will flow in to take its place. D is an ordinary water-gage. An enlarged view of the pump is shown in Fig. 2. It is made from an ordinary bicycle pump. Note that the leather cup is reversed as at I. Two 1/2-inch check-valves are soldered over holes made in the pump body, since it is imperative that the valves be abso-

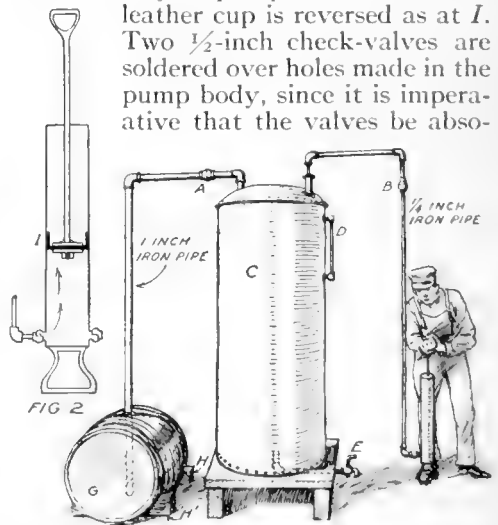

Diagram of a home-built oil reservoir

lutely airtight. The hard rubber composition-washers should be replaced with soft rubber ones. In using the pump the plunger should be forced right down to the bottom.—JAMES E. NOBLE.

Emptying a Bottle

THE contents of a bottle may be emptied, drop by drop, if a match stick bent to form a figure 7 is inserted, by the long end, in the bottle, and held in place. The liquid then runs along the match stick, when the bottle is tilted, and drops off the end of the stick.

# Kite Making at Home—II

## How to Build and Fly the Blue Hill Box, Malay Box Combination and Tetrahedral Cell Kites

By H. S. Rinker

(Concluded from June issue)

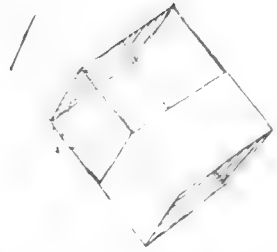

A box-kite is the most practical to build and the easiest to fly

HAVING progressed thus far, variety can be introduced by making some Blue Hill box-kites. These are named after the Blue Hill Weather Observatory, Massachusetts, where they were originated. They look like Fig. 16.

Make 4 sticks  $\frac{1}{2}$  in. square, but otherwise proceed as described for the Malay kite. All kite sticks *must* be worked out in this manner to assure the absence of cross or twisted grain. Otherwise they may fail when you least expect it, and make more trouble than if made right at first. Several ways of bracing have been used, but the writer has had best results from the one shown. Put the frame together as indicated in Fig. 18.

Two of these side frames are needed for each kite. For bracing, nothing is better than a bamboo pole, about  $\frac{3}{4}$  in. in diameter. Take a piece of this about 4 ft. 6 ins. long and rip it exactly in half, from each end until about 4 ins.

in the middle remain uncut. Wrap this part with wire and solder. Then it will appear as shown in Fig. 19. Spread it out on your bench and hold with wire nails as illustrated in Fig. 20.

Now at points marked A, cut a shoulder, so that you can spring the brace into the holes in the hardwood strips. Take two strips of cambric 19 ins. wide and *hem both sides*, making them 18 ins. when hemmed. Pull out the puckers and square one end. Measure

12 ft. 1 in. and square the other end. Sew up with a half-inch seam. You now have two endless loops, each exactly 12 ft. long and 18 ins. wide. Glue the seam to the other sides of one stick. Slip the other side frame into the

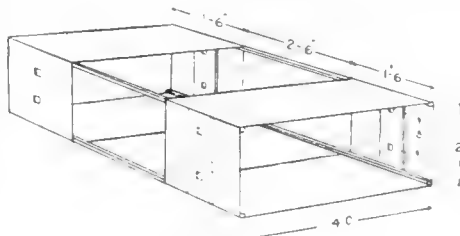

Fig. 16

loop, put in the stretchers, adjust the sails smoothly, mark with a pencil, take down and glue. When knocked down this kite folds flat. It cannot be rolled.

The bridle is a loop of twine tied to the sticks at the inner margins of the cambric.

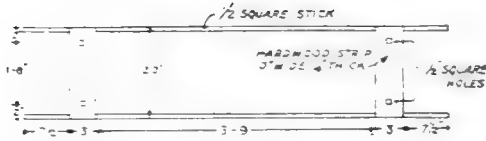

Fig. 18



Fig. 17

Carefully find the exact center of the bridle loop and tie a loop knot there. This settles for all time the point of attachment of the flying string. This kite flies higher than the Malay kite, when bridled as described. By moving the bridle back carefully, a point can be found where the kite will fly low and pull like a mule.

The next type is the square box. It is shown in Fig. 21.

The directions for the Blue Hill box practically cover this, except the bracing. For this case place the hardwood strip vertically, glue and brace as before, with the differences shown. Cut the two holes side by side in the hardwood strip. Glue the spreaders to the side ribs, cut the shoulder on them at the right length, and spring into the holes. Bridle with a single string tied at the point where the inner edge of the cambric of one end crosses one stick. When knocked down this kite will lie flat.

*The Malay Box Combination*

This kite will add a large spread of

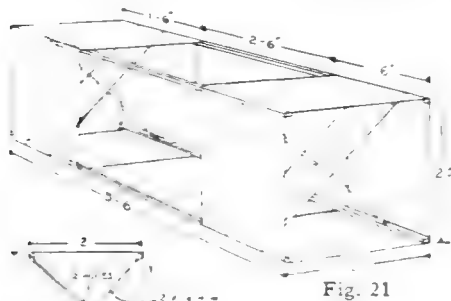

Fig. 21

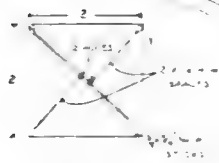

Fig. 22

sail to the kite described in the foregoing paragraph, by the addition of one stick. Make this stick 8 ft. 4 in. long. Make it 1 in. wide by 1/2 in. thick. Notch the ends for the bowstring as



Fig. 19

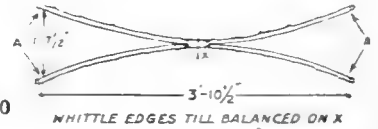

Fig. 20

WHITTLE EDGES TILL BALANCED ON X

described for the Malay. When put together it appears as shown in Fig. 23. This is exactly like two halves of a Malay kite, Fig. 24.

Make the bowstring stick so it can be dismounted, as described for the Malay. This kite is a beautiful flyer, and always attracts much attention when in the air. Three of these this size are all that can be safely handled at one time. This kite will knock down flat by removing the bowstring and bow. This kite, as described above has about 32 ft. of sail.

*The Tetrahedral Cell*

This kite is the invention of Professor Alexander Graham Bell, and is a scientific wonder. To begin with, a tetrahedron is a solid geometrical figure made by four surfaces, each of which is an equilateral triangle, all of these triangles being of equal size. A tetrahedral cell kite cuts out two of these triangles. The remaining triangles are the flying planes. In its simplest form

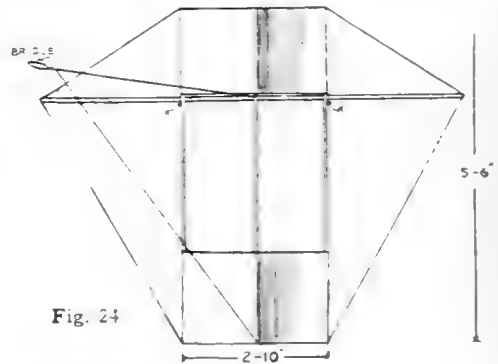

Fig. 24

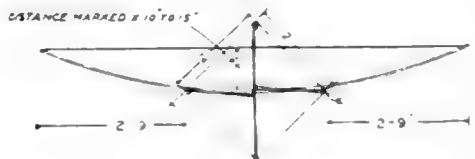

Fig. 23



Flying this kite will afford much pleasure. It is a most delicate and ethereal object at a great height, looking like a flock of soaring birds more than anything else. It is hard to make, but it pays its way when finally finished in the pleasure it gives its possessor.

#### A Few Words About Flying

Have a pair of gloves, duck or canvas with pieces of sole leather sewed in, to handle the flying line, if you use wire. The strain should never come on the reel. A clamp like this, made of cast-iron with two wing-nuts, should be used to clamp on the wire. A short piece of chain with a  $\frac{1}{2}$ -in. rod at the end 15 ins. long is attached. The rod is pushed into the ground up to the eye, and the foot is held down on it to prevent its pulling up from the strain. The chain should be as strong as the flying wire. Of course if cord is used for the lower part of the flying wire, it can be handled by snubbing around the frame of the reel, or any convenient stationary object such as a fence post, fire-plug, chimney, etc., when a large battery is aloft.

Smaller kites can be made by reducing the above proportions, and correspondingly lighter equipment can be used. If Malay kites less than 3 ft. high are used they can be covered with paper, although, owing to the imperfect pocket, the headsail action is not so pronounced, and the kite does not fly as steadily as one with cloth sails.

#### An Emergency Fountain-Pen

**S**ELECT two pen nibs of the round variety and place them together, one above the other, in the penholder. This expedient not only enables one to write about sixty words with one dip in the ink, but prevents the ink from dropping off the pen and blotting the paper.—W. LUHRS.

#### Making a Two-Fuse Switchblock

**T**O obviate the annoyance of fitting up a new fuse when one has blown out, a switchblock may be made, which carries two fuses. A block of fiber,  $\frac{1}{2}$  in. by  $1\frac{3}{8}$  in. by 3 ins. is used as a base.

Drill two holes  $\frac{5}{16}$  in. away from each end and  $\frac{3}{8}$  in. from each side, large enough to take a 4-32 bolt. Drill the same size hole in each end of two thin strips of brass, 1 in. by  $\frac{1}{4}$  in. Pass one end of each strip over the bolts and bolt the other ends with two nuts, one underneath and one above the strip. Leave the bolts long enough to receive battery post nuts. The end of the block

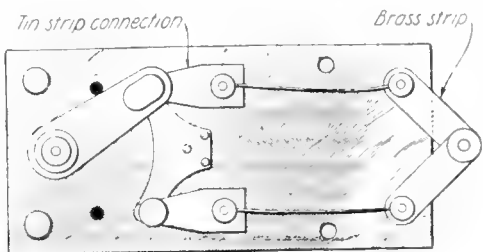

A small convenient switchblock for accommodating two fuses

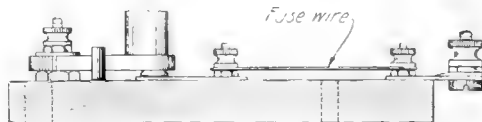

If one fuse blows out simply switch over to the other fuse

just prepared is used as one binding post, the details being shown in the diagrams. The other ends of the strips are bolted tightly to the base, the bolts being long enough to receive battery post nuts. These bolts are to act as the terminals of the two fuse wires.

Two more holes to take 4-32 bolts are drilled  $1\frac{1}{2}$  ins. from either end and  $\frac{3}{8}$  in. from either side of the block. After placing the bolts in these holes, a strip of copper or tin is hammered over them and fastened down with brass screws. File down the screws to form a smooth surface. Another hole for a 4-32 bolt is bored  $\frac{5}{16}$  in. from the end, as shown in the diagram. A piece of brass, 1 in. by  $\frac{1}{2}$  in. by  $\frac{1}{8}$  in., is bored at each end with a 4-32 drill, and slipped over a bolt of the same bore. A block of fiber,  $\frac{1}{2}$  in. by  $\frac{1}{2}$  in. by  $\frac{1}{2}$  in., is bored with a 3-32 drill and forced over the bolt. The bolt is then pushed through at the other end.

A nut is placed between the fiber base and the bar to allow for the thickness of the two contact screws and the head of the nut at the other end of the bar. A double set of nuts are used to hold the nut tight. At the top of the bolt is another battery post nut to be used as the other terminal.—L. A. KUEHNE.

# Experimental Electricity

Practical Hints  
for the Amateur



Wireless  
Communication

## The Construction of an Improved High-Tension Audion Battery

By Charles Horton

**I**N the early days when the audion as a detector was used only to a limited extent, it was generally considered that on account of the extremely high resistance of the path through the telephones and across the vacuum in the bulb, the high-tension battery used to supply this circuit must be good for many years' work. But since the audion has been manufactured and placed on the market and its use has become widespread, it has been found that sometimes the dry cells used for the high-tension battery suddenly seem to lose their voltage in a most unaccountable way and have to be renewed.

therefore, it becomes necessary to test each cell of the high-tension battery, which is a tedious job; and, since the terminals of the cells are usually soldered

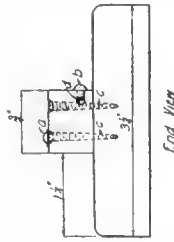

Fig. 2. Two other views of the switch arrangement

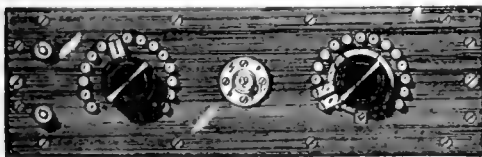
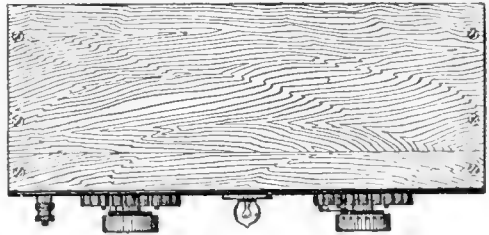

Fig. 1. Showing the arrangement of switches on the case

It has been noted by many experimenters that only certain of the cells become "dead" while the others are apparently as good as when installed. When the audion set refuses to work,

to their leads, the replacing of one or more cells is a lengthy and unpleasant operation. In order to make the cells easily accessible, it is now customary to mount them in a box separate from the audion proper, this box having on one panel the usual high-tension switch and two binding posts from which wires lead to two other posts on the audion cabinet.

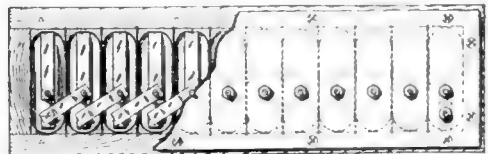

Fig. 3. View of the case with the front panel removed

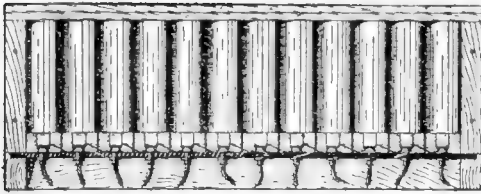

Fig. 4. Another view of the interior of the cabinet

In order to overcome the disadvantage mentioned above and also to eliminate the necessity of soldering the cells, the writer designed a battery case in which the cells are slipped in place from the back and automatically make connection. There is also provided an extra switch mounted on the case which allows each cell to be tested out individually at any time, in a most convenient way.

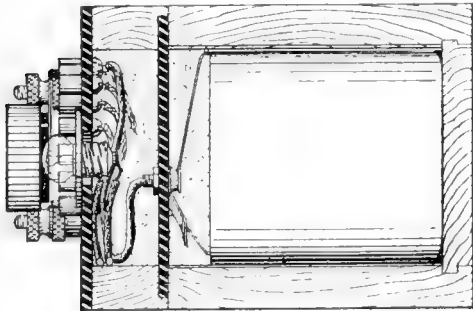

Fig. 5. Sectional view of case taken through testing-lamp

The arrangement of switches on the case is shown at Fig. 1 and Fig. 2 of the accompanying diagrams. In Fig. 1 there will be seen to the left of the panel at the front of the case the usual high-tension switch. This is of the type recently described in this magazine, and in which, to prevent accidental short-circuiting of the cells, there is provided between each pair of live points an extra point. All of the extra points are connected together and act in place of the usual connection to the center of the switch. The points are so spaced and the width of the lever so calculated that the lever cannot in any case cover more than two points, thus making connection but preventing short-circuiting.

The spacing of the points is also such that the switch is smooth and noise-

less. The method of connecting is shown in the diagram on page 134. At the right of the panel is shown the testing-switch, the two levers of which are connected to the lamp shown at the middle of the panel. The first two points of this switch, upon which the lever is shown at rest, are arranged to be "dead;" each of

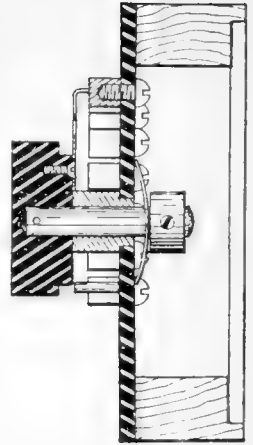

Fig. 6. Section through high-tension switch

the other points is connected with the corresponding point on the other switch. Thus when the testing-switch is turned and its two levers brought into contact with any pair of points, the corresponding cell is brought into connection with the testing-lamp and the relative brilliancy of the lamp is a measure of the condition of the cell. In order to prevent short-circuiting of the cells by the use of this switch, the arms thereof are normally kept out of contact with the points by a spring at the rear. By the use of a spring friction-member, shown at the bottom of the switch, it may be set above any pair of points. Pressing the knob will then make the desired connection with the cell selected. The binding posts at the extreme left are for the wires which lead to the audion cabinet.

An understanding of the interior construction of the case may be gained by an examination of the drawings, Fig. 3 and Fig. 4. Fig. 3 is a view of the case in which the front or switch panel has been removed as well as the top of the case. In Fig. 4 the front

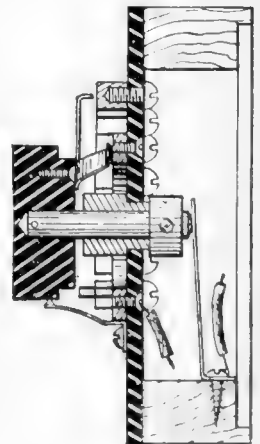
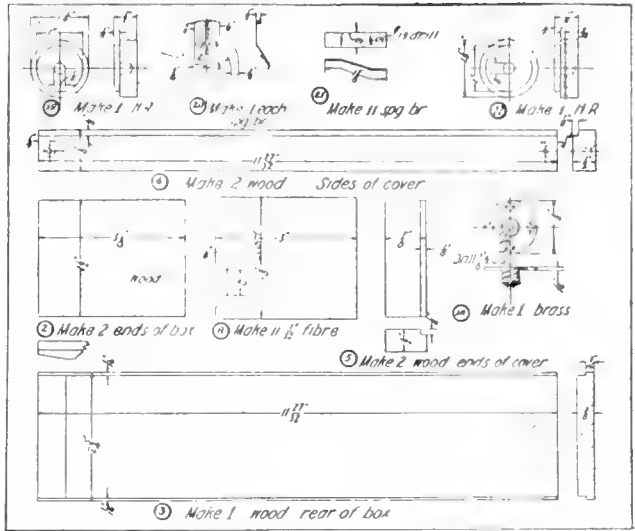

Fig. 7. View through the testing-switch



panel with its wood pieces has been removed and a piece of the second or interior panel broken away to show the arrangement of the cells in the box. It will be seen that the interior of the case is divided into twelve compartments by means of thin fiber strips and at the front of each compartment is a pair of contacts against which the electrodes of the battery are forced by the sliding panel at the back of the case. These two contacts consist of a switch-point and a spring, the switch-point for making contact with the long springlike electrode of the cell and the spring-contact making contact with the short, stiff electrode of the cell.

By the diagonal arrangement of the spring-contacts shown, the use of connecting wires is obviated and an arrangement made whereby all the cells are inserted in the same position. In Fig. 4 these diagonal springs are shown as suspended in mid-air in order to show the method of making contact. The switch-points further act as connections for the leads to the high-tension switch. Between the front panel and the interior contact panel all the connecting wires are neatly placed and well protected. Fig. 5 is a sectional view taken on the line of the testing-lamp and looking toward the left in Fig. 1. The arrangement of contacts and the connecting space at the back of the switches is here clearly shown. It will be noted that the switch panel with its wood backing forms a cover for the battery holder, and is secured to the latter by means of the large screws shown at the right and left-hand ends of the front panel. On loosening these two screws, the cover may be removed and the connections



Details of ends of the case, sliding rear panel, front panel, etc.

examined, yet cells may be inserted from the back at any time without disturbing a single connection.

Fig. 6 is a section taken through the high-tension switch and shows clearly the arrangement of the switch parts.

Fig. 7 is a section through the testing-switch and shows the arrangement of the parts of this switch and also more clearly how the switch arms are normally out of contact with the points.

Consider now the details of construction in diagrams on this and following page: Detail 1 is at the top and bottom panels of the case. The narrow transverse slots are for the fiber separators and may be carefully cut with a hack-saw. The slot in which the sliding-back of the case fits is shown at the back and should be made smooth and true. Detail 2 shows the ends of the case, and 3 is the sliding-rear of the case. At its right-hand end a recess should be made to enable this piece to be slid out easily. Detail 4 is at the top and bottom of the cover or switch panel support, while 5 shows the end-pieces of the same. The fiber separating pieces (6), should be made a rather tight fit in the slots provided for them.

The front panel (7) should be very carefully laid out before being drilled. It may, after drilling, be rubbed down with pumice stone and water to get the dull finish so much desired.

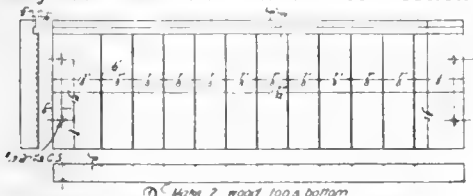

Detail of the top and bottom of the case

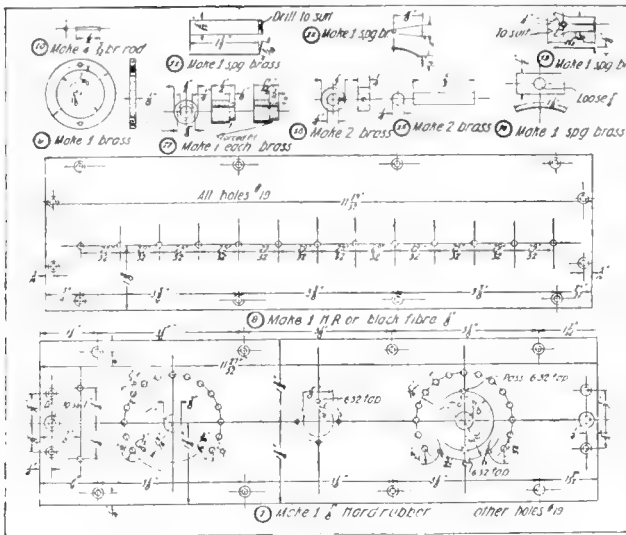

Diagrams of the other details of the battery

Detail 8 represents the interior or contact panel which is best made of fiber.

The contact slip-ring for the testing-switch is shown at 9; 10 shows the stop-pins for both switches.

The spring (11) which keeps the testing-switch contact arms out of contact with the points, is clearly shown in Fig. 7.

The locating spring (12) for the testing-switch, is also clearly shown in Fig. 7.

Details 13 and 14 are the switch arm and friction spring for the high-tension switch.

Detail 15 shows the centers of both switches, and 16 represents the adjusting collars for them.

The bushings (17) for the switches, should be forced in place in the hard rubber front panel.

Detail 18 is of the socket and flange for the testing-lamp. This is made by taking a

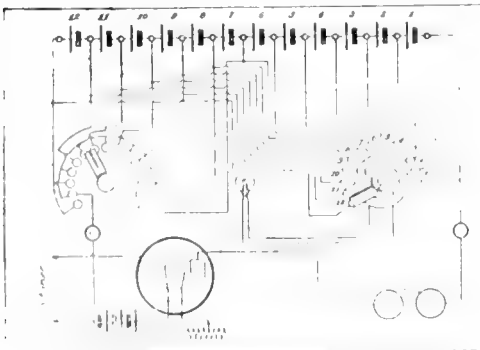

A complete wiring diagram of the battery

"pin-socket," procured from an electrical supply house, and making a flange as shown. The socket is then soldered into a hole in the flange and filed down neatly, making finally a flush socket.

The hard rubber knob for the high-tension switch is shown at 19, the contact springs for the testing-switch at 20. These springs are cut exactly as shown and bent to suit.

The contacts for the cells (21), should be of very springy material and like the other parts, are preferably nickel-plated in order to prevent corrosion.

Detail 22 is of the hard rubber knob for the testing-switch and is drilled around its periphery to accommodate in the proper positions the friction spring shown in detail 12. It is suggested that the locating holes be not drilled until the switch is assembled, as this insures a much more accurate arrangement of the holes.

In assembling, the battery box is first set up and the fiber panel screwed on after having the contact-springs and points mounted on it. Then the fiber separators are pushed into place. The next step is to assemble the switch panel and mount it on its wood supporting top. The switch-points used are standard  $\frac{1}{4}$  in. by  $\frac{1}{4}$  in. heads having an 8-32 screw-hole at the back. The connecting wires at the back are best soldered into small holes drilled into the screws. The connections to the battery contact points on the fiber panel are also preferably soldered into holes in the end of the screw shanks, these points being the usual type. The batteries used are the No. 603 pocket flashlight cell. The length of the battery box given in the drawings allows  $\frac{7}{8}$  in. for each cell but it may be best to measure up a set of cells and by dividing the total length covered by the number of cells obtain a fair average.

The points of the testing-switch and cell compartments should be numbered, so that a defective cell may be picked out immediately.

Rejuvenating Electric Lamps

**D**ON'T throw away your burnt-out electric lamps. They can be renewed by this simple method:

File off the tip carefully so that the globe does not crack. With a pair of tweezers, twist the broken filament together. Obtain from the druggist a piece of yellow phosphorus for five or ten cents. Insert a piece of it, about half the size of a pea, in the bulb. Cautiously heat the top of the globe by means of a Bunsen burner, and melt a piece of chemical glass over the hole, closing it completely.

The phosphorus unites with the oxygen in the bulb to form phosphorus trioxide, a cloudy substance, which will settle in a few days. The globe is now filled with nitrogen.

The greatest caution must be exercised in the use of the phosphorus. It must be handled under water entirely, and with tweezers. Do not touch it.

An Exciter for Electroscopes

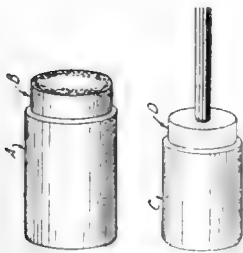

Exciting device

involving no risk of damaging the gold leaves.

Find a small glass jar without a neck, and coat with shellac inside and out. Attach a piece of fur inside the jar, the skin side next the glass using the same solution of shellac in alcohol, as an adhesive. Select a small brass tube closed at one end, that will just slip inside the fur, and after fitting in a sound cork, insert a glass rod for a handle. Cover the cork with sealing wax.

Keep the metal tube inside the fur-lined jar when not in use. By merely withdrawing the former it will acquire a negative charge by rubbing against the fur. From the metal tube an electroscope can be charged negatively by contact, or positively by induction.

**T**HE electrostatic exciter described in the October number of the POPULAR SCIENCE MONTHLY is rather too powerful for use in charging electroscopes. The following is a handy arrangement

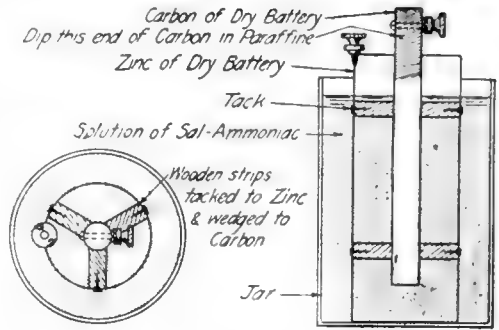

A few minutes' work makes a wet battery from a dry one

A Wet Battery From a Dry One

**T**HE zinc and carbon of an exhausted dry battery may be used to make a wet battery, as shown in the illustration. The carbon should be oven-baked to dry out all impurities. The bottom of the zinc can is removed and a number of wooden strips wedged in, as shown; the carbon should then be tacked in place. The upper end of the carbon is dipped in paraffine, to prevent creeping of the salt. After placing a solution of sal-ammoniac in the can, the zinc and carbon are inserted.—FRANK HARAZIM.

Interference of Lighting Circuit by Static Electricity

**T**HE writer had an electric light that would not last more than an hour without burning out; but during the time that it was in use it gave a very bright light. About nine inches from the lamp cord a belt rubbed at a cross, producing static electricity by means of the friction at the cross. This condition was corrected as shown in the drawing: L is the light. B is the belt, crossing at C; I is a piece of iron connected by a copper wire to a water pipe. G. C. is a ground clamp.

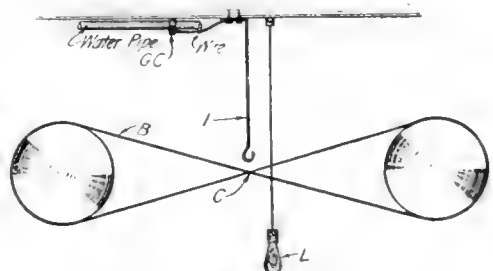

One more static difficulty overcome

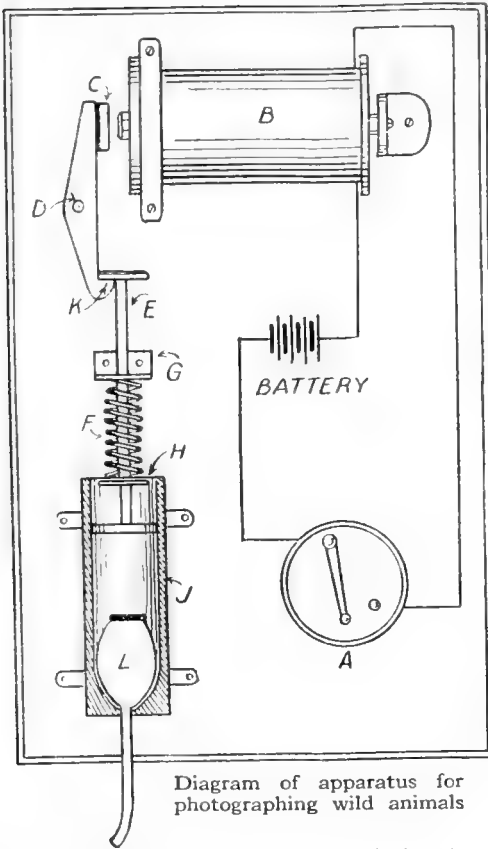

### How to Photograph Wild Animals

IT will often prove desirable to operate the shutter of a camera at a distance, especially in photographing birds, reptiles or animals in natural poses. The device shown in the accompanying illustration serves the purpose, and its construction and operation are simple.

In brief, the description and operation are as follows: The switch, *A*, or a push-button, is mounted where the operator will not be conspicuous, and is connected, in series, with a magnet *B* and several cells of a battery, by means of a flexible conductor, such as a lamp-cord. The magnet *B* is energized when the switch *A* is closed, and attracts the iron armature *C*, which is mounted on an arm, pivoted at *D*. The lower end of this arm is in the form of a latch, which supports the rod *E* when it is raised to its upper position. The rod *E*, when raised as depicted, compresses the coiled spring *F*, which is held between the gage *G* and the washer *H*, mounted on

the rod. A small coiled spring not shown holds the armature *C* away from the core of the magnet *B*. The lower end of the rod *E* is in the form of a piston, which operates in a wooden cylinder *J*. The rubber bulb at the end of the tube leading to the camera shutter is located in the lower end of the wooden cylinder *J*. The device is now complete. As soon as the switch is thrown, the magnet *B* is energized. This moves the latch *K*, and this in turn releases the rod *E*, and the piston at the end of the rod moves downward in the cylinder, on account of the compression of the spring *F*. The piston plunges down on the rubber bulb *L*, causing the shutter to be operated in the camera.

The operator may, of course, be stationed several hundred feet away, and in this case there must be a decided increase in battery power. By means of this outfit, pictures can be secured of shy animals, reptiles, etc., that would never venture out of their hiding places during the presence of a photographer. Many other uses will suggest themselves to the constructor.

### Converting a Key-socket Into a Simple Pull-socket

RIVET together the ends of two strips of stiff brass 3 ins. long and  $\frac{1}{2}$  in. wide. About 1 in. from both ends punch a hole to receive bolts about  $\frac{3}{4}$  in. long,  $\frac{3}{16}$  in. in diameter. Place the key of the socket in the center of the strips and tighten up the bolts. Attach strings to the end of the strips. By simply pulling the strings the light can be turned on or off as desired. The materials for this socket can be found in any workshop.—J. M. COHEN.



A pull-socket made from a key-socket

The materials for this socket can be found in any workshop.—J. M. COHEN.

Electric Striking Mechanism for Mission Clocks

MANY of those who possess a mission wall-clock have no doubt wished that it could be made into a "striking clock." This transformation is not difficult with the following materials: a single-stroke electric belt; a small dry battery; an old flat file; 12 pieces of brass for contacts; a small piece of copper for brushes; and several feet of copper wire, screws, staples, etc.

The first thing to do is to make the large contact (Fig. 1). This is made of pieces of an old file. The file should first be annealed, so that it can be cut up into twelve short pieces. An old file should be selected which has a filing surface on the edge; it is the corrugations of this edge that are to be used to interrupt the current for the striking mechanism. The pieces should be just long enough to include twelve notches or corrugations. The corrugated edge of the pieces should be dressed down by filing or grinding, so that on the first piece only the center corrugation is left, on the second, the middle two, on the third, the middle three, etc. The pieces are clamped together with insulating strips between, in the order of their respective number of corrugations—1, 2, 3, 4, 5, etc.

If the contacts are to be fastened on the outside of the clock, the hands can be used as contact-arms. The large contact plate should be fastened directly opposite 12 (not necessarily over it) and the small contacts opposite the hours. The hands should then be removed and a brush similar to the one shown in Fig. 2 made and fastened to the under side of the minute-hand. Before replacing the hands one of them should be insulated from the rest

of the clock-frame by a small piece of thin silk, wrapped around the stem under the hand. A small brush should be fastened to the under side of the hour-hand to make contact with the small contacts. The brush on [the minute-hand should be adjusted, so that each segment of it will come over a row of corrugations. The brush should be nearly perpendicular to the face, as it goes over the large contact, to avoid touching two at a time. The contacts should then be connected, as shown in Fig. 3, by wires run on the back of the face.

In case the contacts are placed on the inside, it will be necessary to make two contact-arms corresponding with the hands. These will be on the inside and will work over the contacts, as the hands did in the other case. In connecting up the contacts it must be remembered that each piece of file (row of contacts) is to be connected with the small contact opposite the corresponding hour. The heavy dash-dot line indicates the main

wires; one is connected with the *insulated* hand and the other with the frame of the clock. The bell and battery are connected in series. In fastening the wires small pieces of muslin may be glued over them to hold them in place and to avoid using staples or brads in the clock face.

When the hour hand passes over the contact corresponding with, say, the hour 5, the row containing 5 corrugations is thrown in the circuit, and when the minute hand comes around to 12, its brush passes over the large contact. As the current is only in one piece of the file—i. e., the one corresponding with that hour, all the others are dead. The brush trips from one notch to the next, causing the single-stroke bell to strike five times.—R. L. KENYON.



Fig. 2. The brush that is fastened to the under side of the longer or minute hand

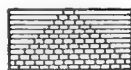

Fig. 1. Making the large contact of pieces of an old file

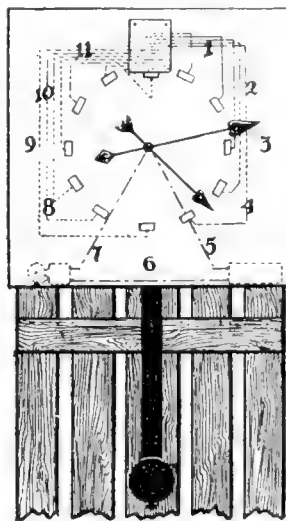
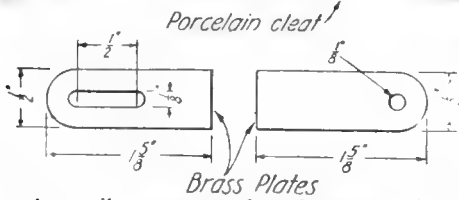
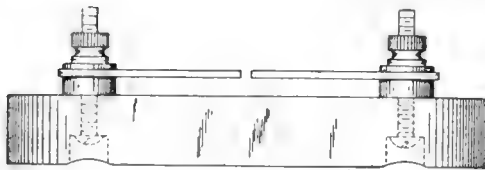

Fig. 3. Contact connections  
A Mission clock with an electrical arrangement for striking the hour



An easily constructed anchor-gap which may also be used as a plain gap for an ordinary spark-coil

**A Simple Anchor-Gap**

THE drawing shows a simple and easily constructed anchor-gap.

All that is required is a porcelain cleat, about 1 in. by 2 ins. of 1/16 in. sheet brass and two common battery bolts. The holes are afterward sealed with some insulating compound. The slot in one plate facilitates fine adjustment, and this gap may be used to advantage as a plain gap for a small spark-coil, as well as for an anchor-gap.—G. DUNFEE.

**Making a Mechanical Interrupter**

MANY experimenters have trouble with the vibrators on coils, since very few work satisfactorily. A mechanical vibrator, run by a small motor may

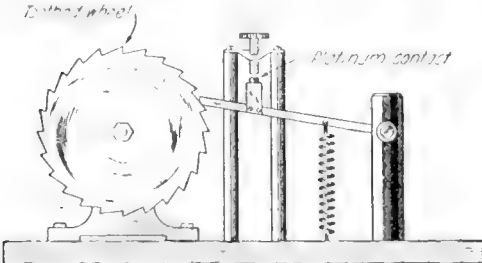

Side view of interrupter

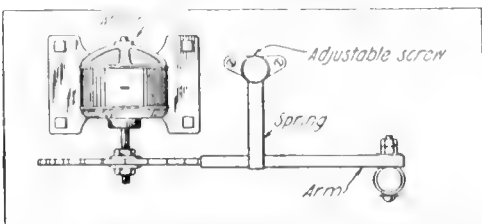

View from above. The vibrator can be made from odd pieces of metal which happen to be at hand

be constructed according to the drawing and will be found to eliminate many of the difficulties. The faster the motor runs, the higher the frequency of interruption.

This vibrator can be constructed from odds and ends, as shown. The toothed wheel should be made of brass, and the teeth cut in with a hacksaw. The vibrative arm is also brass. Soldered to it is a piece of spring steel in which a piece of platinum for one contact is fastened. Two uprights hold the adjusting-screw. The rest of the construction can be seen from the illustration; dimensions are not given, since they may be chosen almost at the will of the experimenter.—H. B. PEARSON.

**Temporary Variable Condenser**

THERE have been described numerous makeshift variable condensers; but the one here shown is about the simplest, and can be made in a few minutes.

A bottle of thin glass is filled with some good conductive liquid such as mercury. If enough quicksilver cannot be had, salt and water or a solution of sal-ammoniac will answer. An insulated wire with the end bared is thrust deep into the liquid and clamped with the cork; this represents one plate of the condenser. The other plate is a tin can or other vessel partly filled with the same conductive liquid and having a wire clamped on the edge. The bottle is suspended by passing the wire through a hole in a small piece of wood, and plugging it at the height required. Care must be taken that the liquid in the can does not reach the wire extending from the bottle.

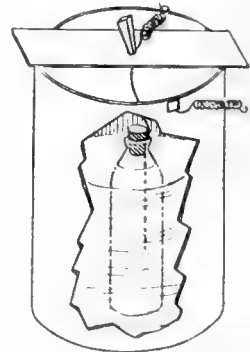

A simple form of variable condenser

Of course with mercury in both and with the outer receptacle made of glass, the best results will be secured. This simple arrangement can be made in a short time, and will be found practical for many simple experiments.

**A Delicate Crystal Detector**

**A**N ingenious crystal detector stand which may prove useful has been invented and patented by J. J. Ghegan. The crystal itself *C*, is held in a spring-clip *11*, *12*, extending from binding post *14* mounted upon the base *10*. A cup may be used in place of the spring-clip, when it is desired to mount the crystal permanently.

Contact with the sensitive point of the mineral is made through fine wire or "cat-whisker" *D*, which is fastened in a screw-closed slot *22* in the end of pivoted-rod *M* to which the adjusting knob *K* is attached. The rod *M* turns freely on pivot *21*, which is supported near the end of the upright rod *A*. The lower end of *A* is in the form of a ball *E*, which fits closely in the spring-socket

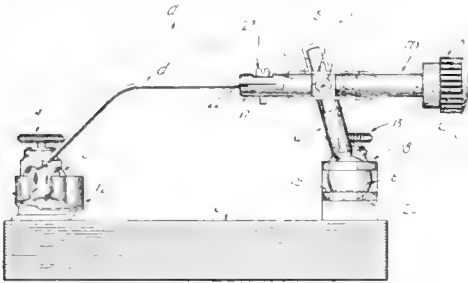

A crystal detector capable of very delicate and varied adjustment

made by pieces 18, 19 and 20.

As can be easily seen, the point of *D* can be moved in any direction by properly actuating knob *K*. The several joints must be made to move smoothly but with enough friction to hold whatever position they may be forced to assume. With this design of holder not only can the point of contact be selected at will, but the contact pressure and the angle of the wire to the crystal surface may be varied widely; all the adjustments are controlled by the thumb and finger through the single knob.

**Radio in the Far South**

**T**HE two southernmost radio stations in the world are at Tierra del Fuego, the extreme southern end of South America, and on Macquarie Island, South of Tasmania and New Zealand. These stations are about as far below the equator as Sitka, Alaska, is above.

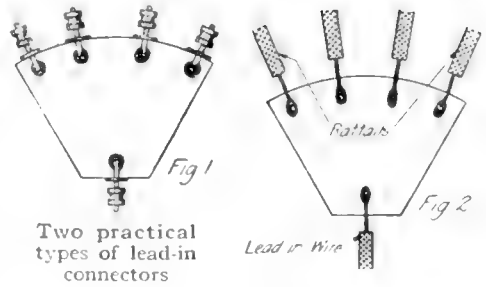

**A Lead-in Connector**

**T**WO lead-in connectors of simple design are shown in the drawings. That of Fig. 2 is made by soldering binding posts, obtained from the zinc shells of old dry cells, to a piece of sheet metal as shown. Fig. 2 shows one of better electrical design in that all connections are soldered. Both will be found serviceable.—E. R. THOMAS.

**An Unusual Code Letter**

**E**XPERIMENTERS who listen to messages passing to and from German or Spanish stations are often puzzled by the code-letter of four dashes. This signal represents the combination "CH" and is used as a single letter in the International Morse or Continental code. Four dashes forming one character in American Morse signify the beginning of a new paragraph. Continued practice alone will clear up the confusion on this point.

**Mounting a Rotary-Gap**

**T**HE noise made by the vibrations of the rotary-gap can be reduced to a minimum by cutting hollow rubber balls in half and placing them under the rotary-gap as shown at *A.A* in the illustration. The sound will be greatly reduced.—E. R. THOMAS.

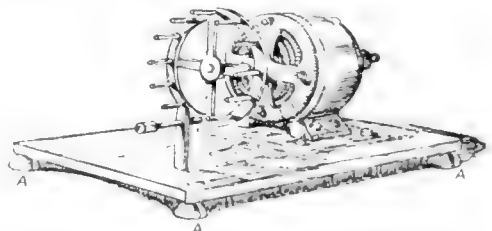

The addition of rubber feet reduces the noise of a rotary-gap to a minimum

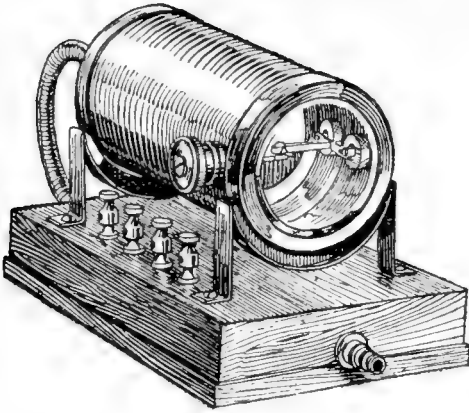

A wireless relay for increasing receiving speed and for relaying to telegraph lines

### Greater Speed in Wireless Receiving

**D**R. RAY E. HALL, of Portland, Ore., has recently developed an invention that may increase the speed of wireless receiving by automatically recording at an average speed of a little more than one hundred words a minute. On test that speed has been increased to as much as two hundred words a minute. Speed, however, is not the greatest factor in the invention, which is called a wireless relay, for by means of this device messages may be automatically relayed to a wire telegraph line by the same action which records the message. This may easily open up new possibilities for wireless telegraphy, by connecting it directly to the wire system. The relay may also be used for receiving a number of wireless messages at the same time, on the same aerial at the same wavelength. Relayed messages are automatically written in ink, on commercial ticker-tape. The ability to receive simultaneously several messages is based on tuning to spark-tone or group-frequency instead of to wavelength only.

The relay is connected with the wireless set in place of ordinary telephones. With the device a whole night's work from Sayville, L. I., 1,500 miles away, has been received at the experimental laboratory. The instrument worked alone in a room by itself, since it has attached to it an automatic starting and stopping device. When the wireless message starts, the very first sound transmitted is placed on record, and

when the message is ended the tape stops.

A light current of air passing through the box and coil into the cylinder shown in the illustration, is the main element employed in relaying the wireless signal. Any commercial record or sounder, electric bell or light can be attached to the instrument to record the messages.

### Receiving Undamped Oscillations

Arrange a piece of fine iron or steel wire, such as that used for the "E" string of a mandolin, over the pole faces of a small horseshoe electromagnet of the kind used in an ordinary buzzer. Mount a contact-screw directly above the wire where it passes across the magnet faces. Connect the magnets in series with an 8 c. p. lamp on the 60 or 120-cycle alternating-current lighting line, and put the iron wire and contact into your receiving-circuit as shown in the diagram.

The arrangement in the accompanying diagram gives a musical note to the signals received from arc or high-frequency alternator stations, the pitch depending upon the number of cycles used in the power line. The vibrating wire must be adjusted so that the contact makes a clean, sharp break each time the lighting current pulls it down. The tuner and detector must be adjusted in the same way as for receiving spark-stations. High-frequency spark-stations can be heard while the wire-interrupter is running, but the notes of their sparks will be changed.

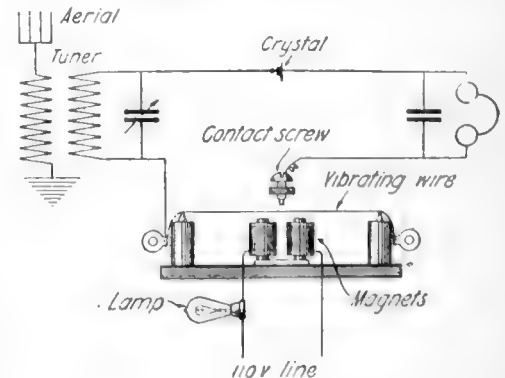

Diagram of a simple receiver for undamped oscillations



**An Electrically Operated Device  
for Lighting Gas**

A SIMPLE and reliable gas-lighting device is shown in the accompanying illustration. The gas is ignited by means of an electric spark, produced between the two parts *A* and *B* of an electric circuit. The circuit is composed of a source of energy, such as a number of dry cells, a kick-coil, the connecting leads, and a special switch, for the opening and closing of the electrical circuit.

The circuit is normally open, but as the lever, controlling the gas valve, is moved or turned from one position to the other, by pulling the chains, the lever *C* is actuated through a certain arc. Now, as this lever *C* moves, its upper end passes the projecting point *B*, which is attached to the upper portion of the burner, and the electric circuit is completed and broken. Just as the point *A* leaves contact with the point *B*, an arc is produced. This electric arc is greatly intensified by the electric kick-coil. The two points *A* and *B* should be made of platinum, since any other metal will not withstand the extremely high temperature of the arc produced.

Pieces of platinum may be obtained from an old incandescent lamp. The contact piece *B* is mounted on the brass collar *D*, by means of a small screw *E*. The collar *D* is held in place by the screw *F*, which draws the two ends firmly together. This collar must be insulated from the fixture or stem by some thin sheets of mica, to prevent a short-circuit. The upper piece of platinum *B*, should extend just high enough to reach the lower edge of the gas flame.

Now mount an arm *C* on the valve stem so that it stands in a vertical position when the lever to which the chains are attached is in a horizontal position. Bend this arm into the form shown in the figure, and cut its upper end off so that it is about  $\frac{1}{2}$  in. below the outwardly projecting end of the piece of platinum *B*. Drill a small hole in the upper end of *C* and, after inserting a piece of platinum, apply some solder. Then the complete burner and the valve are mounted on the gas fixture, and from the collar *D* an insulated wire is carried to the point where the battery and the electric kick-coil

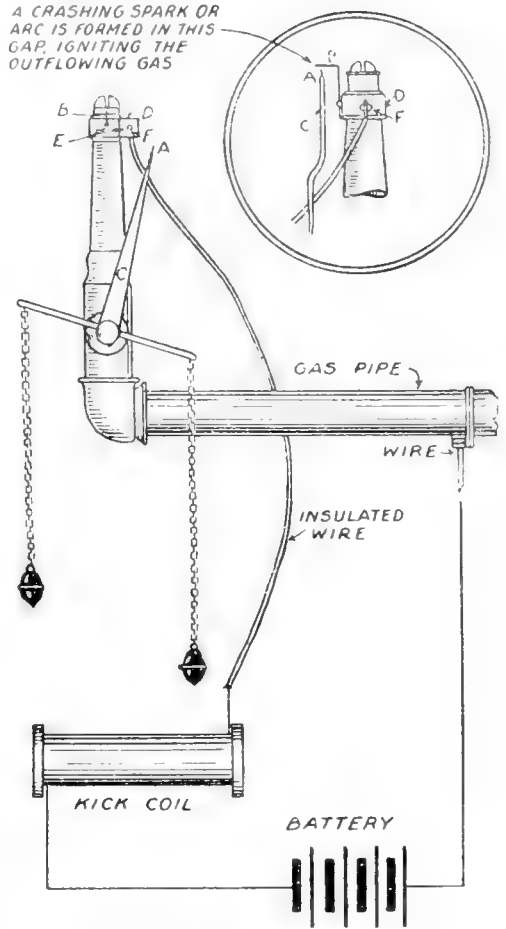

By slowly pulling the left-hand chain, the gas can be electrically lighted

are located. The gas fixture itself forms one side of the circuit, and therefore one terminal of the battery should be connected to the gaspipe, as depicted.

An electric kick-coil, like the one here used, may be purchased in any electrical establishment, or one may be made by cutting up some iron wire or stove wire and fastening the lengths in a snug bundle, gluing and covering this pack of wire with good stiff writing paper. Then six layers of cotton-covered No. 18 gage wire are wound neatly and evenly on top, and of course, each and every layer is insulated from the preceding one by several thicknesses of paper.

At least four dry cells will be required if satisfactory results are desired. Bear in mind that the gas must be escaping from the burner when the arc is formed.

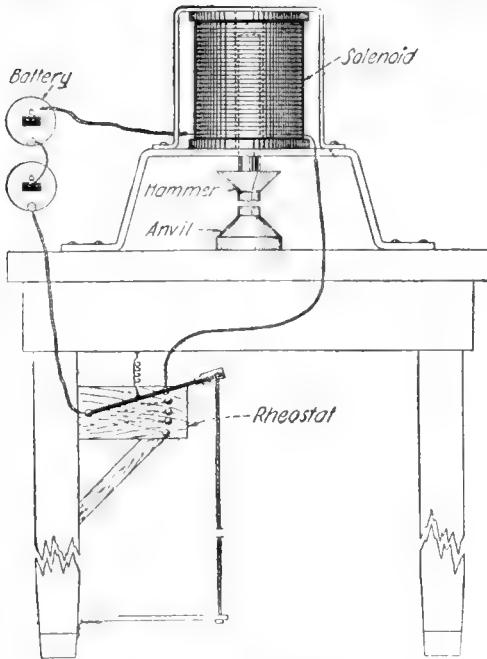

A treadle is used for operating the rheostat of this electrical hammer

### A Model Electrical Hammer

AN electrical hammer is simple and practical in construction and, if built to a fair size, may be utilized in doing small and light riveting work, such as jewelers and model makers encounter. A solenoid or suction-type electromagnet forms the basis of the apparatus. The magnet may be about 3 ins. in length, with end disks about  $1\frac{3}{4}$  ins. in diameter, and a brass or fiber tube of  $\frac{1}{2}$ -in. inside diameter running through its center.

If a metal tube is used, it should be properly insulated by several layers of paper. The coil is formed of No. 16 enameled or cotton-covered wire, wound in even layers and filling the bobbin. The two leads are put into the circuit as shown, with the foot-operated controller or rheostat.

A rheostat is fastened at a convenient level; and a string is attached to a small hook on the end of the rheostat handle and connected with a hinged pedal. A stiff brass spring is stretched between the handle and a point on the rheostat board so that the current is immediately disconnected as the foot is withdrawn.

A small anvil-iron is attached at the bottom of the point where the iron hammer or plunger drops down. On the lower point, the switch or rheostat breaks the solenoid circuit, allowing the hammer to drop heavily on the anvil or object to be riveted. On the top point the coil receives its greatest power from a battery of from 4 to 6 dry cells, which eventually sucks back or withdraws the plunger into the hollow tube in the solenoid magnet. If the foot is lifted up and down, or the handle of the rheostat operated by hand, the hammer will move up and down forcefully.

### Compact Condensers

WHEN mica is used to separate the plates of condensers, the capacity is nearly seven times as great as though the dielectric were simply air. For a given thickness, the voltage may be made about three times that which glass will withstand. Mica is light in weight also, and because of these three features it is being used more and more in radio transmitters.

### How to Make an Attachment-Plug

TO make an attachment-plug of an old fuse-plug, first make a hole in the center of the mica cover, so that a socket-bushing will screw in tightly. Take the cover off by prying around the edge of the brass ring. Seal the socket-bushing on the inside by heating and shaping it like the outside, then bring the lamp end through the bushing, solder the wires to the cap and screw-contacts, put the cover on, press back the rim in place, and you have an attachment-plug.—H. L. BAER.

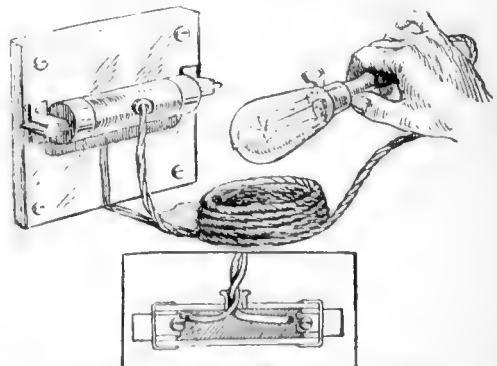

Insert a socket-bushing in a fuse-plug to form an attachment-plug

How to Make an Electric Shaving-Mug

THE general use of electricity in the home has opened up a new field in the way of cooking and heating utensils. Such appliances are usually supplied by electrical houses, but many of the utensils may be easily and neatly constructed at home. One of these is the electric shaving-mug. A mug or cup, capable of standing heat, is the first thing required. An aluminum cup of standard shape and design, which may be purchased in any town, will do perfectly well.

These cups are spun from a flat sheet, and have no seams to open or leak. It is also necessary that no holes be drilled in the mug, since it will be utterly impossible to make such holes watertight again. The heating element must be fastened to the mug with a clamp. This clamp will also allow the heating-coil to be removed for repairs, and makes it easily accessible at all times. The bottom of such a mug commonly has a flange, which makes a recessed part, and in this the heating-element is placed. The legs of the mug are to be made of sheet brass, as shown in Fig. 1, one of the three having a hole near the center for an insulating button (Fig. 2), of "transite" or some other material to hold the supply cord in place. The clamp, for holding the heating-coil, is shown in Fig. 3. This clamp has a screw in the center to tighten it in place.

The heating-coil or element is depicted in Fig. 4, which is a coil of flat "nichrome" wire, or ribbon, as it is called, 12 ft. long, 1/16 in. wide, and 3/1000 in. thick. This is equal, in cross-section, to a No. 26 gage wire. To wind this coil, procure a block of wood, 7/8-in. thick, about 4 ins. sq., with a 1/2-in. hole in the center for an axis or pivot. Clamp a 1/2-in. rod in a vise so that the block can be rotated around it. Beginning at the center, fasten one end of the nichrome ribbon to the block, leaving about 2 ins. surplus to make a connection. Then proceed to wind the ribbon in a spiral coil, separating each turn from the preceding one by a strand of asbestos cord.

A small section of this coil, as it would appear highly magnified, is depicted in

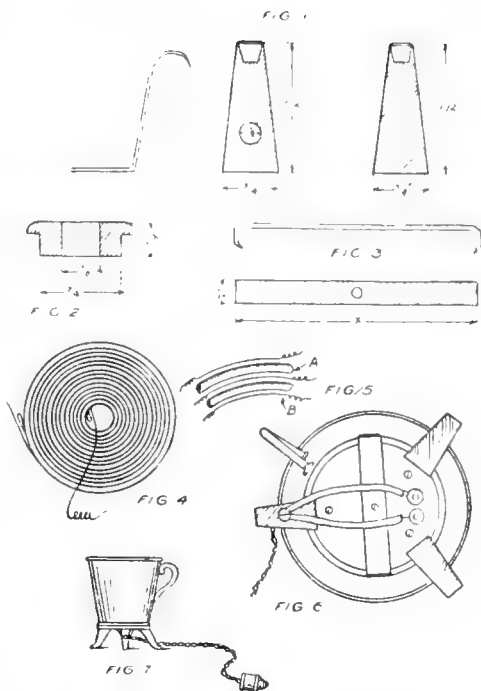

Details of the shaving-cup and construction of the heating-coil

Fig. 5, where A, or the lightly shaded part, represents the asbestos insulation, and B, or the black lines, the ribbon. This asbestos insulates each turn of the coil from the next nearest, and the electrical current must travel entirely through the resistant element, instead of jumping from one turn directly to another, which would be the case, if insulation were not used. The coil must be very closely wound, in order to get it into the very limited space in the bottom of the mug.

Before taking the coil from the block, rub into its surface a little asbestos retort cement, or a cement composed of a mixture of silicate of soda and silica, or glass sand. This mixture, when dry, will tend to hold the coil together, and the current may be passed through the coil, to test it, as well as to bake it in its coiled shape. The support for the coil is a disk made from a piece of 5/16-in. asbestos, wood or transite. Cut it to fit into the recessed part in the bottom of the mug. Then with a chisel, remove enough material from the top of this disk to form a depression, 1/16

in. deep, to receive the coil flush with its top. The leads of the coil are run through the disk. The surface of the coil is then plastered evenly with retort cement. The legs are fastened to a second piece of insulating material with round-headed brass machine-screws,  $\frac{1}{2}$  in. long, with nuts. See Fig. 6.

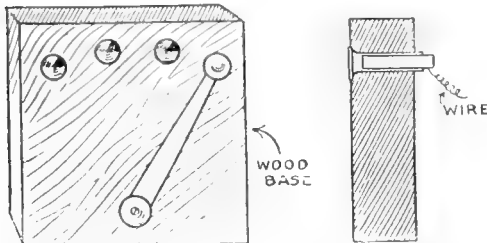

Cartridge shells make neat electrical contacts for a rheostat

### Using Cartridge Shells for Electrical Contacts

**A** NOVEL use for cartridge shells of the old center-fire kind, certain to interest the electrical experimenter, is in making rheostats, small switchboards and important contacts on wireless apparatus, where efficiency is considered. A hole a trifle smaller than the diameter of the shell is made in the base and the cartridge shell forced into the hole made, as shown in the diagram.

The proper wires are then soldered to the metal on the inside, or the wire may be placed inside of the shell and held securely in position by driving a wooden plug into the empty shell, as depicted. A complete rheostat may be so made. The heads of the shells offer efficient contacts.

### The Best Crystal Detectors

**I**N spite of the fact that crystal detectors play so important a part in the experimentation of electrical amateurs, their use is not understood as well as it should be. There are various combinations in use. It will be found, in general, that the more sensitive a crystal is, the more readily will it lose its adjustment or "knock out" from loud signals or static. The average amateur will get more satisfaction from using a single crystal than from a combination. For example, although perikon has many desirable characteristics, there is apt to be trouble from particles of one of the crystals rubbing

off, and adhering to the surface of the other. This is constantly occurring.

Chalcopyrite and zincite, arsenic and silicon, and antimony and silicon are all used in combination, and are remarkably sensitive. An occasional wash with carbon disulphide helps to remove grease and dirt from the surfaces, and often restores them to sensitiveness.

Carborundum is proof against all manner of knockouts, but is unfortunately not very sensitive. A stiff wire or needle makes the best contact with this substance, and should be pressed down into it with considerable force. A battery must be used with this detector.

Silicon is more sensitive than carborundum, and is correspondingly more easily knocked out by static. A light contact is required, and the efficiency is often improved by applying an exceedingly small potential.

Galena is probably the most sensitive of the crystal detectors, but is hard to keep in adjustment. It is especially sensitive to static. The wire used should be as fine as possible. Certain violin and mandolin strings are wound with very fine silver wire; this wrapping is most suitable for use with galena.

A minute fraction may be cut off the end of the wire from time to time, thus always insuring a clean point. Cerusite requires about the same treatment as galena. Iron pyrite works best with a firm contact, and is almost as sensitive as silicon.

### Testing Electric Lamps Quickly

**W**HERE many incandescent lamps are tested, much time is lost in screwing them in and out of the testing-socket. This can be remedied by means of an ordinary porcelain lamp-socket.

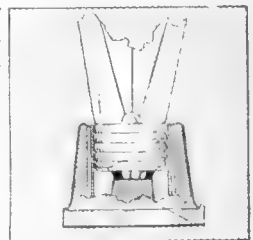

A test-socket

Remove the inner shell and hammer its threads down on a  $\frac{5}{8}$ -in. pipe. The diameter should then be great enough to admit the threaded base of the lamp. After replacing the shell, lamps can be readily tested by merely sliding them into this socket.

# What Radio Readers Want to Know

## When Is the Transmitter in Good Condition?

Ricardo Moran Pereira, Guayaquil, Ecuador, S. A.:

The information you request concerning the operation of wireless telegraph equipment is mainly covered in the various textbooks of wireless telegraphy, but not specifically taken up in any particular one. The necessary tests for determining the condition of radio telegraphic apparatus are so well understood by those engaged in the work that the authors have neglected to take up this phase of the subject.

The condition of the secondary winding of a high potential transformer may be tested in the following manner: Connect a small spark-gap in shunt to the secondary winding and supply the primary winding with correct value of potential. If a good fat spark discharge is not secured at the secondary terminals even when the gap is of excessively short length it is an indication that all or a portion of the secondary winding is short-circuited.

The open circuit in the primary winding of a transformer may be determined by connecting a 16-candlepower incandescent Edison lamp in series with the circuit. If the lamp does not glow it indicates that the circuit is open. If the primary winding is short-circuited the fuses will blow whenever the circuit is closed.

A breakdown of the high potential condenser is generally directly visible.

Violent brush discharge at the condenser is an indication of excessive voltage or a spark-gap of too great length. It is also sometimes due to the irregularities in the coatings which may have jagged edges. To some extent brush discharge can be prevented by immersing the condensers in oil or by the use of a series-parallel connection, thereby dividing the potential between several banks.

Regarding the matter of induced potentials from the aerial system, in any radio installation every effort should be made to keep the low potential power wires at a distance from the high-frequency circuits. In any event the low potential power mains should be placed in the iron conduit, the latter being directly connected with the earth.

The condenser is prevented from discharging into the secondary winding by means of high-frequency choke-coils which generally consist of four to ten turns of copper wire wound in the form of a pancake spiral with the turns spread about  $\frac{3}{4}$  in. The inductance of these coils has little effect upon the potential of the secondary winding but offers a very high impedance to the high-frequency currents of the condenser.

The dimensions of the condenser are limited

by the wavelength to be employed. In the case of a 1 k.w. set operated from a source of 60 cycles, it is customary to use a condenser having capacity of .012 microfarads; 2 k.w. sets employ capacities varying from .018 microfarads to .036 microfarads.

To go into these matters more in detail would require the space of a small textbook, and we believe that your queries taken as a unit are best answered in a publication entitled "Textbook of Wireless Telegraphy" by Rupert Stanley. This book is probably the most up-to-date one on the subject, as it gives the theoretical principles and the practical details of modern commercial telegraph apparatus.

## Receiving 3,000 Miles

I. E. R., Cuenca, Ecuador, writes:

Q. 1. Can you give the dimensions and the best type of an aerial for the reception of signals to a distance of 3,000 miles? This aerial is to be used with the Navy type of loose-coupler.

A. 1. If this aerial is to be employed for wavelengths up to 3,000 meters from stations using damped oscillations, the flat top portion of the aerial may consist of four wires spaced  $2\frac{1}{2}$  ft. apart, 350 ft. in length, and from 120 to 200 ft. in height.

Q. 2. What is the least expensive detector that could be used for the purpose?

A. 2. Any of the detector minerals such as galena, cerusite, molybdenite, silicon and carborundum are inexpensive. The audion is the most sensitive detector in existence, but of course is more expensive than any of the foregoing.

## Flickering of Lights

E. B., Centralia, Ill., inquires:

Q. Why should a  $\frac{1}{2}$  k.w. transformer make the lights flicker, and what can be done to remedy this?

A. When the condenser connected in shunt to the secondary winding of the transformer discharges across the spark-gap, the secondary winding is temporarily short-circuited, and unless the magnetic circuit of the transformer is arranged to have a certain amount of magnetic leakage, the primary winding will draw an excessive value of current. You may perhaps be able to lessen this effect by changing the capacity of the condenser or by inserting a reactance coil in series with the primary winding. It is also possible to connect a reactance coil in shunt to the telegraph key. When connected in this manner a portion of the energy constantly flows into the primary winding, and the remainder or the full intake flows when the key is depressed. This method has often been found to assist matters materially.

### Windings for Receiving-Tuner

P. K., Somerville, Mass., inquires:

Q. 1. Will a loose coupler having oval tubes for the primary and secondary winding be as efficient as one using round tubes?

A. 1. Yes, practically so.

Q. 2. Which is preferable for the windings, cotton or enameled copper wire?

A. 2. Cotton wire is generally preferred to enameled wire, but it is the general practice in commercial apparatus to use single silk-covered wire.

Q. 3. Are No. 22 B & S and No. 32 B & S wire correct for the primary and secondary of an inductively-coupled receiving-tuner?

A. 3. Yes, but generally No. 24 or No. 26 is used for the primary winding.

### Detailed Dimensions of a 3,000-Meter Tuner

G. O. B., Kimbolton, Ohio, inquires:

Q. 1. Please give explicit instructions for the construction of an inductively-coupled receiving-tuner for all-around amateur work, taking particular care to state the number of turns necessary for the primary and secondary windings, also the number of taps to be taken from these windings.

A. 1. For all-around amateur work, the receiving-tuner should be responsive to wavelengths inclusive of 3,000 meters. The primary winding should be  $5\frac{1}{2}$  ins. in length by 5 ins. in diameter, wound closely with about 300 turns of No. 26 wire. The secondary winding should be 5 ins. in length,  $3\frac{1}{2}$  ins. in diameter, wound closely with 500 turns of No. 32 wire. The inductance of the primary circuit may be altered by means of a multipoint switch or by a sliding-contact. It is customary to fit this winding with two switches in some tuners. For example: The first ten individual turns of the winding may be connected to a ten-point switch; the remaining turns are connected in groups of 10 to the contact-points of a second switch. In this instance you require a 29-point switch for the groups of ten turns. The turns of the secondary winding may be equally divided between the taps of a ten-point switch. This secondary winding should be shunted by a variable condenser of a small capacity, say .001 microfarads, for tuning.

### Small Power-Transmitter

G. W., Elk City, Okla., inquires:

Q. 1. Will a spark-coil from an automobile have sufficient power to act as a wireless transmitter for a distance of two or three miles?

A. 1. Yes, provided the potential is sufficient to jump a gap of at least  $\frac{1}{4}$  in.

Q. 2. Will telephone induction-coils serve the same purpose?

A. 2. Generally, no. If the potential of the secondary of the coil is sufficient to give a small

spark-discharge, it may be used for extremely short distance work, but not otherwise.

Q. 3. Will a steel tower interfere with the reception of messages if the aerial is attached to it?

A. 3. No, not if the wires are swung out at a distance from the tower.

### Receiving Aerial

W. L., Seacaucus, N. J., writes:

Q. 1. Please advise if an aerial of four wires 20 ft. in length by 20 ft. in height has sufficient dimensions to receive wireless telephone messages with an ordinary telephone receiver and a crystalline detector.

A. 1. To begin with there are no wireless telephone transmitting stations in operation from which you could receive signals. The experiments at the Naval Station at Arlington to which you probably refer were conducted on a wavelength of 6,000 meters. Your aerial is entirely too small for adjustment to long waves. A single wire from 500 to 800 ft. in length could easily be loaded to a fundamental wavelength of 6,000 meters.

### Long Wave Receiving Tuner

P. A. J., Jr., Suffolk, Va., writes:

Q. 1. I propose to wind the coils for a receiving tuner on two tubes; one is 11 ins. in length by 6 ins. in diameter and the second 12 ins. in length by 5 ins. in diameter. What size wire should I use and to what range of wavelength will it be adjustable?

A. 1. Use the 11-in. tube for the primary winding and cover it with No. 24 S.S.C. wire. Connected to the average amateur aerial, it will permit adjustments inclusive of 6,000 meters. 750 feet of wire are required for this winding.

The secondary winding requires approximately 1,250 feet of No. 30 S.S.C. wire. Connected in shunt to a small variable condenser, it will respond to wave lengths between 8,000 and 9,000 meters.

### Licensing of Sending Stations

R. D. S., Ripley, Okla., inquires:

Q. 1. With a transmitting set composed of a  $\frac{1}{2}$ -in. spark-coil, small oscillation transformer and glass plate condenser, would I require a U. S. license if my station is located 65 miles from the State Line and 15 miles from the nearest radio station which is a college experimental station located at Stillwater? If a license is required please give the necessary instructions for obtaining it.

A. 1. During the daylight hours the range of this apparatus will not exceed 20 miles and in consequence a license is not required. It is equally probable that the signals from this station will not extend over the State Line during the night hours.

# The Home Workbench



## Making a Washing-Machine From a Barrel

A VERY serviceable washing-machine can be made from an old barrel-churn whose capacity is from fifteen to twenty-five gallons. First construct, of heavy galvanized-iron, a cylinder about 30 ins. long and of the same diameter as the head of the churn. One end of this cylinder should be left open and the head of the churn, with its locking-device, fastened to the open end. Find the balancing-point of the cylinder with the head on. Fasten the churn bearings on with rivets and solder to make a water-tight joint.

Make two screens of galvanized wire, with about 1-in. mesh. One of these is suspended from the movable head by  $\frac{1}{4}$ -in. galvanized-iron rods, and the other is fastened in the cylinder, so that they are about 10 ins. apart and occupy the middle part of the cylinder.

In the diagrams I represents the cylinder; 2, the movable head; 3, the brackets which hold it; 4, the bearings; 5, the frame supports; 6, the handle; 7, a small drain-cock; 8, the locking device for the head; 9 and 10, the screens, and 11, the rods that support the top one.

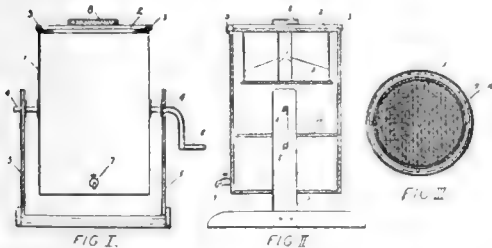

By fitting two galvanized-iron wire screens in a barrel-churn, a serviceable washing-machine can be made

The action is, of course, the same as that of the churn, the clothes being confined between the screens; the water, surging back and forth thoroughly cleans them.—J. FRANK DWIGGINS.

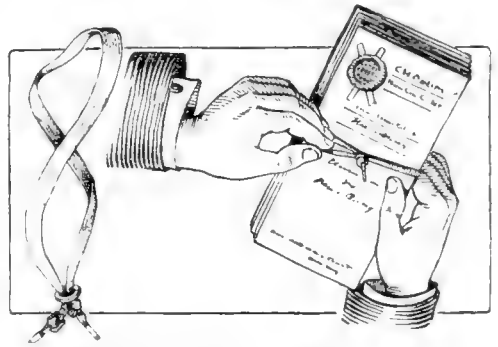

The simplicity of this tape is its chief merit. When drawn up taut, a tiny ring holds it securely in place

## A Package Tie Made of Tape

RECOGNIZING that the string is best for tying a package of papers, it only remained for some one to work out a method of making a holding device that would not require making a knot and have something that would hold the papers tightly, yet be of such character that it could be quickly released.

This tie has been accomplished by a small ring placed on a piece of tape, the tape having knots in the ends to prevent the ring coming off. It is only necessary to slip the looped end of the tape over the package and pull on one end of the tape. To release the holding grip, pull on the other end of the tape. The tapes are made up in various lengths to suit the packages. This invention will add to the efficiency of any office, at small expense.

## Making a Lawn Chair

THE accompanying drawing shows a chair for use on the lawn. The materials required are hardwood strips  $\frac{7}{8}$  in. by  $2\frac{1}{2}$  ins.; one  $\frac{3}{8}$  in. round iron or steel-rod threaded on each end with two nuts; two  $\frac{3}{8}$ -in. bolts,  $2\frac{1}{4}$  ins. long under the head; two  $\frac{3}{8}$ -in. bolts  $2\frac{3}{4}$  ins. long with two nuts each; two  $\frac{3}{4}$ -in. or  $\frac{7}{8}$ -in. dowels,  $2\frac{1}{2}$  ins. long; one strip of awning stripe duck, or stair crash, 20 ins. wide, one piece of  $\frac{1}{2}$ -in. pipe, some  $\frac{3}{8}$ -in. washers, and from twelve to sixteen ounces of upholsterer's tacks.

To make the chair shown cut two strips  $4\frac{1}{6}$  ins. long, and two strips say forty to forty-six inches long. Mortise near top of the two long strips for the crossbar. Cut the mortise  $\frac{7}{8}$  in. by 2 ins. in size. The crossbar is 1 ft.  $\frac{1}{10}$  ins. long with a  $\frac{1}{4}$ -in. shoulder on each side at each end  $\frac{7}{8}$  in. long.

At the other end bore a  $\frac{3}{4}$ -in. hole in each strip and fit a  $\frac{7}{8}$ -in. dowel into it. This dowel is also 1 ft.  $\frac{1}{10}$  ins. long. All these joints should be carefully squared, fitted tight, glued and wedged. Glue the wedges before you drive them, and make chisel-splits for starting the wedges. Do the same thing to the shorter pieces. Bore a  $\frac{3}{8}$ -in. hole in both short pieces at the upper end. This is for the bolt holding the arm-rest. Cut out the arm-rests, as shown in the illustration, for the adjustable hooks. These hooks are made by boring  $\frac{1}{2}$ -in. holes in the exact center of the strip and making saw-cuts to remove the wedge of

wood. Round both ends and also round the top ends of the shorter frame.

Lay off fifteen inches from the bottom of the long frame, and twenty-five inches from the bottom of the short frame. Bore  $\frac{3}{8}$ -in. holes in both, at the points marked. The steel pivot rod,  $\frac{3}{8}$ -in. diameter, is twenty-five inches long. It is threaded on each end for a hexagon nut. Six  $\frac{3}{8}$ -in. common washers, and a piece of  $\frac{1}{2}$ -in. wrought-iron pipe 1 ft. 8 ins. long are required.

Put the rod through the hole in the short frame. Put on a washer; then through the hole in the long frame, another washer; slip on the piece of pipe; a washer; hole in the long frame; a washer; hole in short frame; another washer. Put a washer on the outside of the short frame, and put on both nuts; screw up fairly tight, and burr the end of the rod, riveting it down on the nuts, so they cannot back off.

Pivot the arm-rest in the hole at the top of the short frame, with a  $\frac{3}{8}$ -in. bolt  $2\frac{1}{4}$  ins. long under the head, but make it a loose fit, and burr down the threads to keep the nut in place. Bore a hole through the side-bars of the long frame, 2 ft 3 ins. from the top. Put into each hole a  $\frac{3}{8}$ -in. bolt,  $2\frac{3}{4}$  ins. long under the head, with a thread 2 ins. long. Screw up a nut on this thread until it joins. Push the thread through the bored hole from the outside, screw up the other nut tight, and burr the threads. The notches in the arm-bar hook on this bolt and make the chair adjustable.

Fasten the crash or canvas to the crossbars with tacks, tacking on top, and taking a full wrap of the canvas around the crossbar so that the tacks are covered. This prevents strain on the tacks when the chair is in use. Allow slack as shown, so that the body of the sitter cannot touch the crossrod. The canvas will conform to the body like a hammock. The chair should be painted or varnished for protection against the elements.

This practical lawn chair can be subjected to much wear and tear without suffering any damage.—H. S. RINKER.

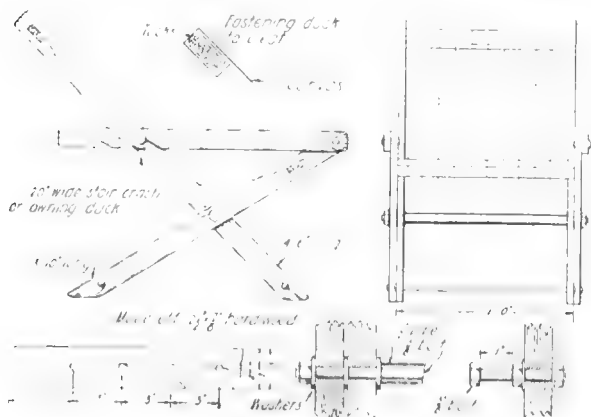

This adjustable chair, which can be made by an amateur from ordinary materials, forms an attractive summer feature of the lawn



# How to Make a Sewing-Screen

**I**NSTEAD of a workbasket, with spools of thread, buttons, scissors, embroidery, hoops, etc., all crowded into a small space, a screen can be used, which has a definite place for every article used in sewing. The spools of thread are kept on brass pegs; the silks in one place and the cottons in another. The scissors, pincushion and emery ball are suspended from hooks. Patterns, embroidery-hoops, buttons, etc., all have pockets where they are readily accessible and yet kept in good shape. Best of all, the screen is light and can be easily carried from one room to another, or on to the veranda. In sewing, a small shelf may be lowered for holding the work. With a few materials anyone handy with tools can make this ornamental and useful piece of furniture. The materials needed are as follows:

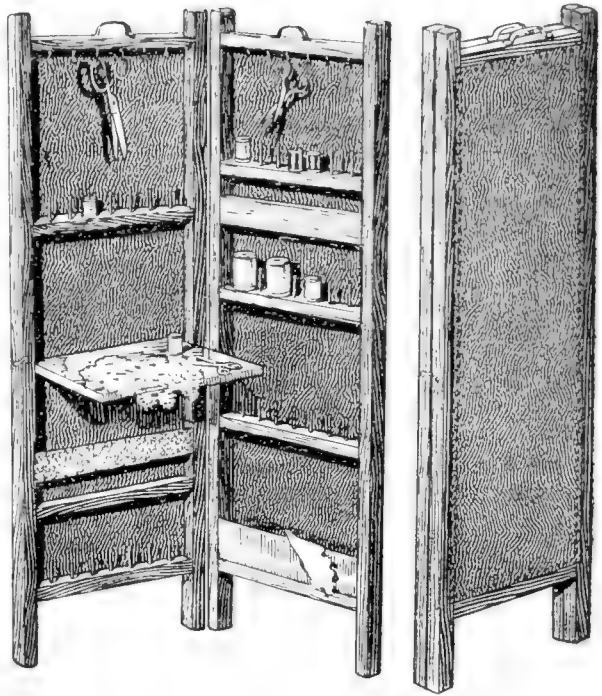

The screen can be easily carried from one room to another, or on to the veranda

## WOOD FOR FRAME

4 pieces	42 ins. by 1½ ins. by ¾ in.
9 "	12¼ ins. by 1½ ins. by ¾ in.
1 "	12½ ins. by 9 ins. by ½ in.
1 "	12¼ ins. by 3½ ins. by ¼ in.
1 "	12¼ ins. by 1¾ ins. by ¼ in.
1 "	12¼ ins. by ¾ in. by ¼ in.

## LEATHER FOR COVERING

2 pieces	13¾ ins. by 36 ins.
1 "	13¾ ins. by 8 ins.
1 "	13¾ ins. by 4 ins.

35 brass pins, 2 ins. long	4 short screws
2 hinges; and screws	12 hooks
1 hook and eyebolt	100 fancy tacks
2 handles; and screws	50 nails

Select two of the longer or upright pieces, and on them indicate with a pencil the points for attaching the cross-pieces. Suppose the left-hand side of the screen is to be made first. The upper edge of the uppermost cross-piece should be 1½ ins. from the tops of the posts. The top surface of the next lower cross-piece should be 13¼ ins. from the tops of the posts. The one next the bottom is 31½ ins. from the top; and the under

surface of the bottom piece is 4¼ ins. from the floor.

On two of the cross-pieces drive seven long brass pins an equal distance apart, as shown in the illustration, taking care to have their tops all even. It is better to drill holes slightly smaller than the pegs before putting them in, especially if the wood is oak or other hard wood. Into the under surface of the top cross-piece screw seven eyebolts, as shown.

Next, assemble the posts and cross-pieces. Use fine wire nails, being careful not to split the wood. Strong hot glue should be applied at the same time to secure greater strength. Before proceeding allow the work to become thoroughly dry.

On the inside of each of the two upright posts, about 3¼ in. from the back edge and 22 ins. from the top, insert a screw, allowing it to protrude about ¼ in. Then, holding the shelf, which is the rectangular piece, 12 1/8 ins. x 9 ins.

x  $\frac{1}{2}$  in., in position, with its upper edge just under these screws, locate the two points for its pivoting screws. This is clearly shown in the illustration. The pivoting screws will work more easily if the holes are first made with a slightly larger screw. The back screws hold the shelf in a horizontal position when it is being used. At other times, it can be raised to a vertical position between the posts.

The top and bottom pieces on the right side have the same location as those on the left. The second cross-piece is 10 ins. from the tops of the posts. Just under it is attached the piece  $12\frac{1}{4} \times 3\frac{1}{4} \times \frac{1}{4}$ . This piece does not need to be nailed; glue will answer. Attached to its under edge and projecting forward horizontally, is the narrow strip,  $12\frac{1}{4} \times \frac{3}{4} \times \frac{1}{4}$ . Attached to the front edge of this piece, and slanting forward obliquely, as shown in the illustration, is the piece,  $12\frac{1}{4} \times 1\frac{3}{4} \times \frac{1}{4}$ . These three pieces should be nailed to one another with two or three fine wire nails, which can be readily concealed.

The third cross-piece on the right is  $18\frac{1}{2}$  ins. and the fourth piece 27 ins. respectively, measured from the tops of the posts. Before joining them to the uprights, they should be fitted with brass pins, as shown. The top piece should be provided with hooks.

Before proceeding further, the various parts should be varnished, stained or painted, according to individual taste. If the screen is to be used in a bedroom having white woodwork, white enamel may be used to advantage. If the woodwork is mahogany or oak, the screen can be finished to match. After the parts are thoroughly dry, the leather or other covering is put on. If leather is used, it should match not only the finish of the screen, but the color scheme of the room. If white enamel is used, a pretty chintz pattern is very effective as a covering, or silk may be used. In putting on the leather or chintz, be careful to stretch it tightly over the frame, gradually proceeding from top to bottom, inserting the tacks on both sides simultaneously. The edges should be folded in about  $\frac{1}{4}$  in.; and the tacks should be driven into the middle of the frame. If silk is used, it may be shirred on a cord at the top and

bottom, instead of being tacked. The two inside strips which form the pockets at the bottoms are attached by turning in their edges and tacking on the inside. The measurements given are large enough to allow for folding in the upper edges several inches.

Lastly, fasten two small brass hinges on the back,  $7\frac{1}{2}$  ins. from the top and bottom, respectively. On the front, attach a hook and eyebolt,  $18\frac{1}{2}$  ins. from the top, for holding the two parts of the screen together when not in use. On the top cross-pieces fasten two brass handles, as shown. They should be near the front inner edge of the frame, so that they will come together when the screen is closed.

### Fitting Windows With Weights

IN the illustration is shown the way in which seventy-five windows in a factory building were fitted with sash cords, pulleys and weights. The method is simple, inexpensive, neat and the pulleys and weights are out of the way. The upper end of the window frame is cut away at an angle as shown, just enough to make a seat for the pulley. This brings the weight in the corner at the inside edge of the window frame and against the building wall. The other end of the rope is fastened to a screw-eye in the top of the window sash. These weights, when out of order can be repaired by anyone.—M. E. DUGGAN.

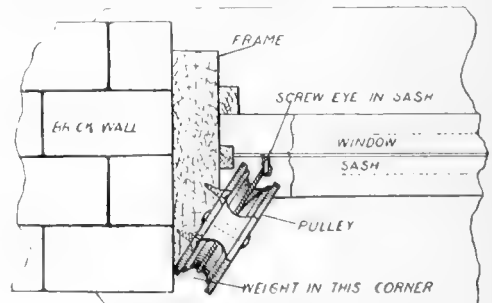

An efficient window device

### How to Remove Iodine Stains

THE dark brown stains caused by iodine are unaffected by soap or other cleaning substance. To remove, let the article soak over night in starchy water, which will remove all trace of the stain.—R. L. BIRD.

**Building a Poultry-House with a Skylight**

**S**OMETHING out of the ordinary in poultry-house construction is shown in the accompanying plans. All the windows are in the roof. The house stands the long way, north and south, so that during the day the sun's rays will reach all parts of the coop. The secret of building poultry-houses right is largely a matter of admitting the greatest possible amount of sunlight. In the plan shown this factor is well cared for.

This house is 21 ft. by 33 ft., with eaves 5½ ft. from the grade. The walls are of hollow clay tile and 5 ins. thick. The foundation and the floor are of concrete mixed 1:3:5.

The structure has a simple gable roof covered with prepared roofing. The roof is at third pitch; rafters at 2 ft. centers. Matched sheathing is used as a roof foundation. Every other skylight sash—on both sides of the peak of the roof—is hinged to be opened for ventilation and airing. A 20-in. galvanized ventilator is placed at the rear, and in the rear gable-end is a barn-sash, which is hinged to swing up.

A coop of this size will comfortably shelter more than a hundred full-grown birds. The covered nests are built in along the side walls, and the roosts are all at the rear end of the house. Materials, such as lumber, tile, and cement, as listed herewith, will be needed:

17 bbls. cement for floor and footing.....	\$24.00
8 yards clean, coarse, sharp sand.....	8.00
12 yards well-graded gravel or stone.....	12.00
650 hollow clay building-blocks.....	26.00
1 dozen anchor-bolts 5-8 in. by 12 ins. . .	1.00
4 pcs. 2 ins. by 6 ins. by 16 ft. for platés	
35 pcs. 2 ins. by 4 ins. by 14 ft. for rafters	
16 pcs. 1 in. by 6 ins. by 16 ft. for cross-ties	17.00
1000 ft. 8-inch ship-lap for sheathing.....	30.00
8 squares three-ply roofing material....	24.00
12 skylight-sash 4 ft. by 4 ft.....	24.00
1 barn-sash for rear, 4 lts. 10 ins. by 12 ins.	1.00

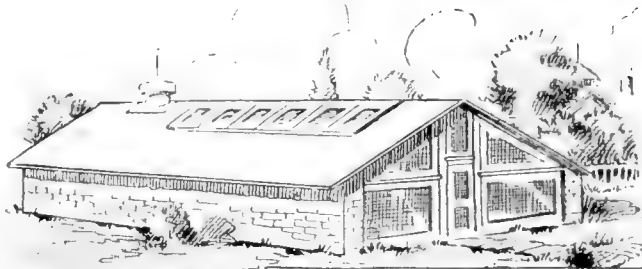

A poultry-house which considers the interests of the hens is here described. All the windows are in the roof. The walls are of hollow tile, the floor is of concrete and a galvanized-iron ventilator furnishes fresh air. Poultry-houses should admit the greatest possible amount of fresh air

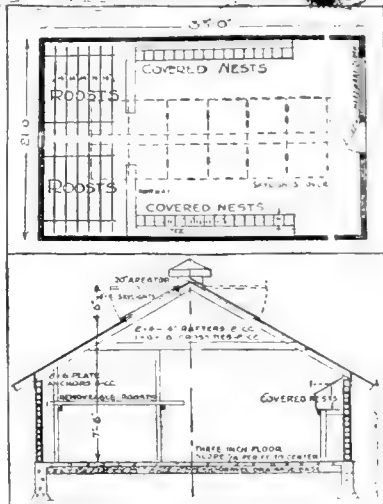

1 galvanized metal ventilator 20 ins. . . .	12.00
200 ft. lineal 1 in. by 4 ins. finish lumber .	2.00
125 ft. lineal 1 in. by 6 ins. finish lumber .	2.00
36 ft. galvanized metal ridge-roll.....	2.00
1 screen door 3 ft. by 7 ft.....	2.00
125 sq. ft. 1-2 inch hardware cloth.....	6.00
24 pcs. 2 ins. by 4 ins. by 10 ft. for roosts and supports	
5 pcs. 1 in. by 12 ins. by 16 ft. for nests . .	7.00

Total..... \$200.00

W. E. FRUDDEN.

**Some Curtain Suggestions**

**S**EW two small rust-proof hooks at the extreme lower corners of your lace curtains on the right side. On sweeping day or when you wish the windows open, hook them up any desired height out of the way. The weight will not stretch the mesh in the least.

Use small round wooden toothpicks to pin your curtains to the rod, and avoid the unsightly rust spots made by common pins by sewing on small bone or brass rings of substantial design.

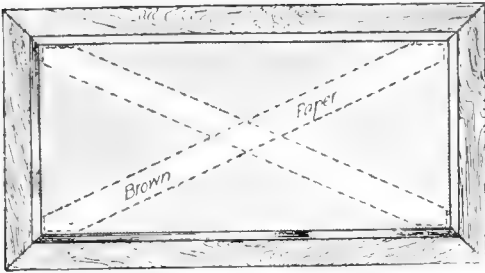

Two strips of strong paper are an effective means of protecting a mirror from breaking

### How to Pack Mirrors to Prevent Breaking

WHEN mirrors are to be stored or to be shipped by mail, they may be securely packed in the following manner: Carefully paste two strips of stout brown paper diagonally across the mirror, as shown in the illustration. In the case of very large mirrors, use several strips of paper. Then wrap carefully in heavy Manila paper.—G. H. HOLDEN.

### A Clothes-Line Prop That Will Not Drop or Slip

AN improvement over the ordinary clothes-line prop is shown in the accompanying figure. It is made of spruce,  $1\frac{1}{4}$  in. by 2 ins., and as long as needed. A hole is cut at the top, as shown. This allows the user to raise or lower the line without allowing the prop to fall. Yet it can be detached readily. The slanting cut at the bottom prevents slipping on the ground and the point may be shod with a piece of hoop-iron.—JAMES E. NOBLE.

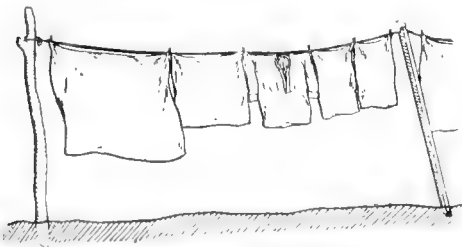

This prop is stable yet detachable



A piece of hoop-iron strengthens the lower end. An L-shaped notch at the upper end holds the line securely

### A Hoop with a Guiding Hub

THE attached drawings illustrate an improvement over the old-style hoop.

Instead of a plain hoop, four spokes with a hub are added, and in place of the plain, straight stick, for giving the hoop motion, a stick with a slight up-curve at one end is used.

This hoop may be started from the hand as well as stopped and picked up without stooping, and is at all times under control. Motion to the hoop is given by pushing it along as shown at the left in the illustration below. A straight view of hoop, with a notch for the stick on either side of hub, is also shown, as well as the method of holding, starting and picking up the hoop by means of this curved stick.

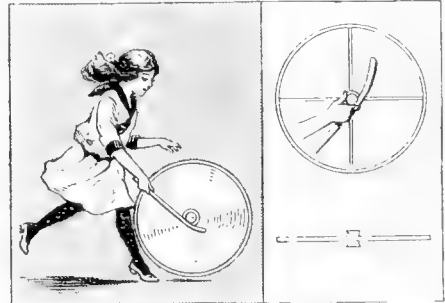

An ingenious hoop has a hub for guiding

### Wood Blocks for Flooring

CREOSOTED wood blocks, already extensively used as paving material for city streets, have been coming into use as flooring for the last four or five years. Durability, noiselessness under heavy traffic, and sanitary properties are chief advantages for paving and also give special value for making floors, especially for use where heavy trucking, the moving of heavy machinery, or other severe use makes the maintenance of floors a serious problem. The rather high cost is the chief disadvantage in the use of wood blocks.

Wood blocks are now widely used for flooring in factories, warehouses, machine shops, foundries, various types of platforms, wharves, and docks, and for such miscellaneous purposes as hotel kitchens, hospitals, laundries, and slaughter houses.

**Finding the Right-Sized Nail**

**H**AVE you ever hunted for a nail of a certain size and finally used one that was either too small or too large? You probably have, though a case could be made which would obviate all such difficulties. A deep box, of convenient size for carrying around, and filled with trays partitioned off to hold the different sizes, makes a good case. In the top tray, place the nails which you are most likely to need. They should also have the largest compartments.

If a stationary case is desired, a sort of cupboard with pigeon-holes can be attached to the wall of the barn or garage. A wooden strip about an inch and a half in width, can be tacked along the bottom of the pigeon-holes to keep the nails from rolling out.

**Improving a Kitchen Knife**

**C**OOKS in hotels and restaurants are much annoyed by the use of light American-made "French knives," which when used for any length of time each



A piece of wood fitted on to the back of a knife-blade saves pressure on the hand

day form a calloused place on the fore-finger. To remedy this condition the writer has thought of a little device which helps considerably. Take a short length of dowel, saw a groove in it, and slip it in close to the handle. It may be riveted on if desired, as shown in the illustration.—PAUL REX.

**An Improved Roller-Towel**

**A**NEW arrangement for roller-towels consists of an upright frame attached to the wall. It has two boxes, one at the top and one at the bottom, with a space of 2 ft. between them. The folded towel is stored in the upper box, from which it descends over rollers to the lower box. The towel is used in the space between the boxes. By drawing on the towel, a fresh portion can be had at all times.

Not only is this towel arrangement desirable for hotels, restaurants, clubs and the like, but it is also perfectly suitable for a private bathroom in the home.—F. P. MANN.

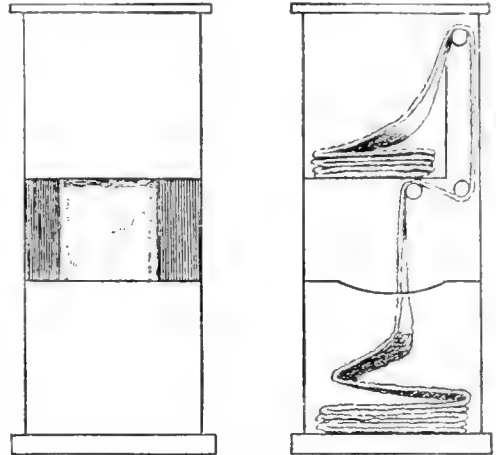

This towel rack presents a fresh portion of the towel at all times

**Let Your Ice-Cream Freeze While Motoring**

**A**VACUUM freezer which will freeze cream automatically in half an hour, and keep it frozen for eight hours, is a recent addition to modern picnicking equipment. The vacuum between the outer wall and the ice compartment causes the ice to spend all of its force on the cream, thus insuring more speed and less cost than the old method. One filling of ice will freeze two fillings of cream. In using this new device the cream is poured in one end and the ice and salt in the other, thus preventing any possibility of grains of salt in the ice-cream. If the freezing is begun when a motoring party leaves home, the ice-cream will be ready when they reach the picnic ground. The freezer, being made of white enamel-ware, is sanitary and clean.

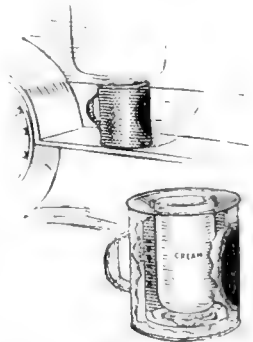

A vacuum ice-cream freezer

### To Screen Doors and Windows

IN screening doors and windows, it is highly desirable that the wire screens should not bulge or wrinkle, and that they should be as taut as possible between the frames. In the accompanying illustration, a method is shown for accomplishing this. One end of the door or frame to be screened is made

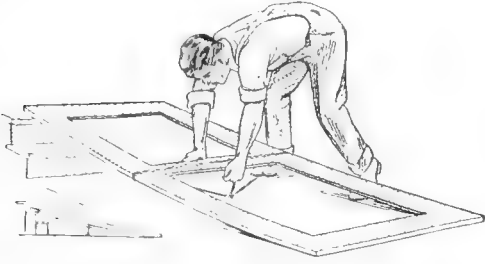

Here is a simple way of stretching a screen taut on a frame

to rest on the steps, and the other rests on the floor or walk. By means of a piece of wire or cord and the screw-eye in the floor, the center of the door is sprung so that it is held 3" or 4" below the sides. The door must be held in this sprung position until the wire screen has been completely tacked in place. The tacking should begin at the center and proceed to the corners of the frame. When the tacking is completed, the door or frame can be released from its taut position; and it will be found that a neat job, with a well-stretched screen free from wrinkles and bulges, will be the result.—E. B. WILLIAMS.

### A Home-Made Table-Top Varnish

FOLLOWING is a recipe for a good varnish, suitable for experimental and wireless benches, and also for instrument bases. It gives a finish very much like hard rubber:

Mix enough lampblack with shellac to make the mixture black, but not enough to thicken it much. After sandpapering the wood smooth, apply two coats of the varnish, sandpapering lightly after each coat. Over this put one or two coats of dull varnish. This makes the wood waterproof, preserves it, and improves the appearance of the table-top.

### Concealed Ventilation

THE diagram shows a simple scheme of ventilation, which may be employed on any window by extending the top of the upper half so that it pockets higher into the wall. When the window is in position for ventilating, the top is pulled down slightly, as shown in Fig. 1. This permits air to enter through the "middle joint," as indicated by the arrows, and it is deflected upward, just as it should be. The top, it will be noted, is still sealed.

The appearance of the window when closed is shown in Fig. 2. It always looks like an ordinary window, and the absence of any attachment makes it the acme of simplicity.

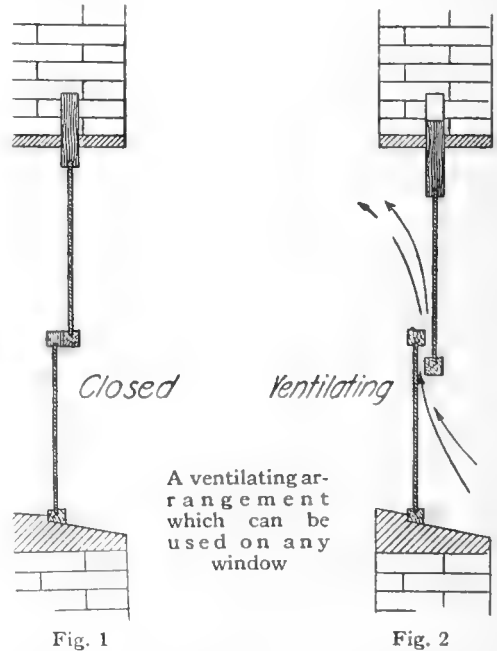

### Removing Heat Spots from a Table

THE white spots, caused by hot dishes, can be removed by rubbing fresh lard on them. The lard should be rubbed in with the fingers. If the spots are very bad it will be necessary to leave the lard on a few hours. It is then rubbed off with a soft cloth. The lard will not injure the finish of the table. A finely polished dining-table, otherwise ruined by hot dishes, can be thus reclaimed.

A Merry-Go-Round Swing

A MERRY-GO-ROUND swing is easy to make if the following directions are carefully observed.

The necessary materials and their exact measurements are as follows:

- 1 pipe 2 ins. by 8 ft. . . . . For vertical shaft
- 2 pcs. 1 in. by 3 ins. by 10 ft. . . . . For cross-arm
- 2 iron rods  $\frac{1}{4}$  in. by 6 ft. . . . . For cross-arm guys
- 2 pcs. 2 ins. by 4 ins. by 6 ft. . . . . For foundation cross
- 4 pcs. 2 ins. by 2 ins. by
- 4 ft. 3 ins. . . . . For center bearing braces
- 2 pcs. 2 ins. by 8 ins. by 8 ins. (oak) . . . . . For bearings
- 2 iron plates 6 ins. by 6 ins. . . . . For bearings
- 2 machine bolts  $\frac{1}{4}$  in. by  $2\frac{1}{2}$  ins. . . . . For top bearing
- 4 machine bolts  $\frac{1}{4}$  in. by
- $4\frac{1}{2}$  ins. . . . . For bottom bearing
- 4 lag-screws  $\frac{1}{4}$  in. by 3 ins. . . . . For top bearing
- 4 carriage bolts  $\frac{1}{4}$  in. by
- $2\frac{1}{2}$  ins. . . . . For cross-arm ends (2 to each end)
- 2 carriage bolts  $\frac{1}{4}$  in. by
- $4\frac{1}{2}$  ins. . . . . For cross-arm center blocks
- 2 pcs. 1 in. by 10 ins. by 18 ins. . . . . For seats
- 16 ft. Manila rope . . . . . For swings

Any soft wood will be suitable.

Begin with the foundation-cross, Fig. 1. Find the center of the two cross-pieces; half notch them to fit flush, and nail together. The foundation-cross is then ready to receive the bottom bearing, Fig. 2. Bore a hole  $2\frac{1}{4}$  ins. in diameter in the center of the block. Bolt one of the iron plates between the block and the foundation-cross, using two machine bolts  $4\frac{1}{2}$  ins. long. This completes the foundation-cross and bottom bearing. The top bearing is made the same as the bottom bearing, only the hole runs through the iron plate.

The four braces are sawed at the ends to an angle of forty-five degrees, and firmly nailed to the ends of the foundation-cross, thus bringing the ends together at the top. Next, the top bearing is firmly screwed on the end of the braces, using four  $\frac{1}{4}$ -in. by 3-in. lag-screws, taking care first to bore the holes with a gimlet. Now we will put the center shaft into place. If a pipe of the given dimension is not available an old boiler-tube of the same dimensions will answer the purpose. For the cross-arm Fig. 4, the two pieces of the dimensions above given are bolted together at the ends, using two bolts to each end.

Now bolt two blocks 1 in. on each side of the center, the blocks to be 2 ins.

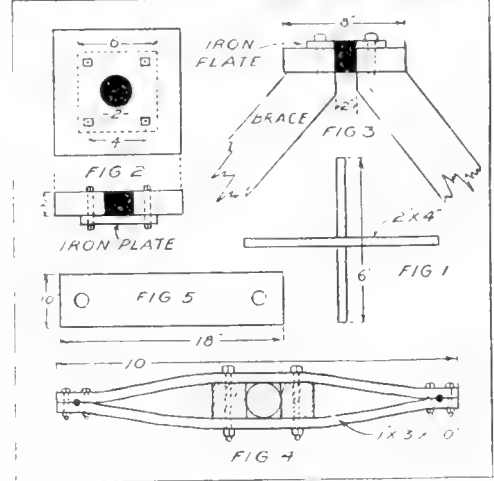
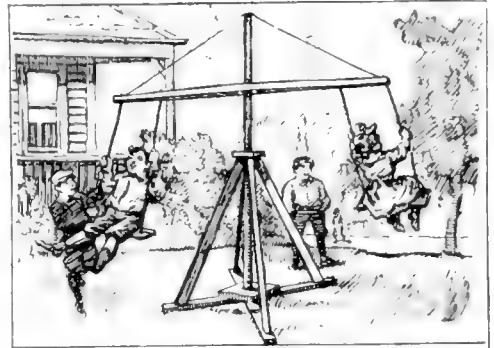

This open-air swing can vie with the Pied Piper of Hamelin

thick. Thus we have a hole 2 ins. square, enough space for the center shaft to run through. Now bore a  $\frac{1}{4}$ -in. hole at each end of the arms to receive the stay-ropes, which are threaded at one end only, the other end being bent in the shape of a hook to catch on the rim of the center shaft. Now slip the cross-arm over the shaft, bolt the ends of the rods to the ends of the arms, and hook the other ends on the shaft. Make the two boards for the swing seats Fig. 5, with the dimensions already given; bore a  $\frac{1}{2}$ -in. hole at the ends of the boards to receive the rope. Now run the rope through the holes and knot them so that they will not slip out of place, the swings being tied to the cross-arm. The merry-go-round swing is now complete and can be set firmly by driving stakes into the ground at the end of the foundation-cross and securely nailing them.—O. B. LAURENT.

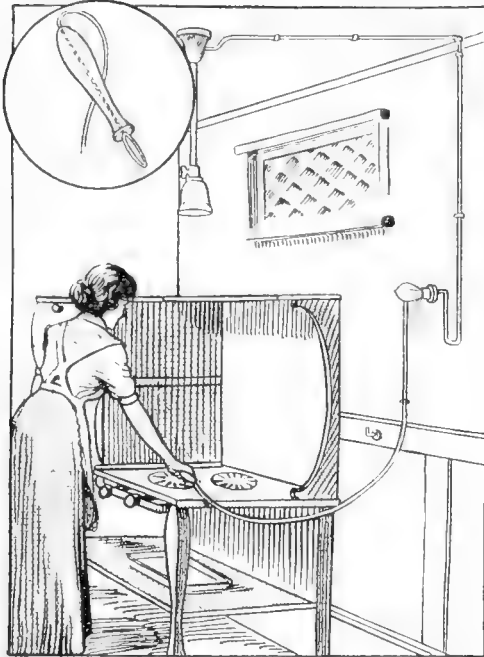

An electrical attachment for lighting the gas-range can be installed in any kitchen

### How to Make a Practical Gas-Range Lighter

**T**HE following gas-range lighter is one in which there are no parts to get out of order, no coils and no batteries. Once installed it will last for years without attention. The illustration will serve to show how the connections are to be made. In detail they are as follows:

Procure a 250-watt bulb, or, if not available, a 100-watt bulb will answer the purpose for a 110-volt direct-current circuit, which is the current generally supplied to homes. Obtain a socket, two pieces of single-strand flexible cord and a wooden handle through which there has been made a hole. Connect the two wires to the socket and extend one end of the wire over to the chandelier in the kitchen and connect this to one of the wires inside the canopy at the top, being careful to clean both by scraping with a knife. Be sure to replace the insulation. Then place the bulb in the socket. Turn on the current and touch the gas-range with the free end from the bulb. If the light burns, the connection at the chandelier has been made correctly. If not, disconnect the wire and connect

it with the other wire at the chandelier. The light will then burn when connected with the range as before.

Now suspend the light from the ceiling. Run the end of the cable through the handle and solder to the end of it a piece of heavy copper wire in the shape of a ring. Push back into the handle until it is tight.

To light the gas-range, all that is necessary is to turn on the gas, take down the handle and touch the range at the point where the gas is issuing and it will light immediately. Light may also be used as an auxiliary by leaving it connected to the range. This arrangement will light the stove 10,000 times, for from ten to twelve cents' worth of current. This will not work on a stove that is connected to the main by means of a rubber hose, unless there is a wire connected to the stove and to a gaspipe in addition to the apparatus just described. This device works just as well on an ordinary gas-jet as on the range.—C. B. CLOUD.

### Making the Cellarway Serve Two Purposes

**I**N a small house shelf space for storage was scarce and the following plan was made available for shelving the wall of the inside stairs to the cellar. A hinged door was made to fit over the stair-well and to fold back against the wall when the stairs are in use. A pulley and weight move the drop door easily and make of it a temporary floor upon which one may walk to reach the shelves. The use of the pulley is not necessary, provided the door is made of some light, soft wood.

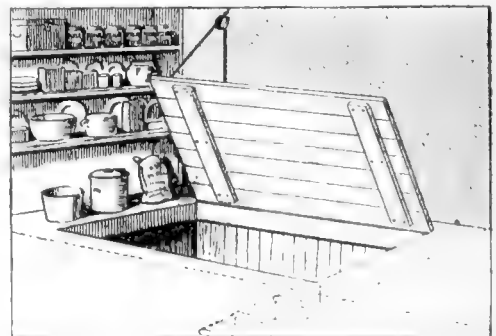

This stairway saves space



For Cleaning Leather Upholstery

HOUSEWIVES are apt to use most any kind of oil, grease or even furniture polish on the leather upholstery of their furniture, and frequently with very bad results. The oils soil the clothing and the polish ruins the leather.

To overcome this trouble a sales manager of a large eastern furniture house made tests of many fluids prepared for the purpose, some of which were very satisfactory. Finally a chemist was consulted, and the reply was, "Use sweet milk." The furniture house immediately tried the use of mopping the upholstery with milk, and the results were very gratifying. The leather should be gone over three times annually, and after being smeared for several minutes, the milk should be wiped off with a clean cloth. The leather will be sufficiently oiled, thoroughly cleansed and will not soil the clothing.

How to Make a Door-Mat from Old Rope-Ends

TAKE a piece of canvas about 18 ins. by 30 ins., hem it all around and mark it off in lines about 1 1/4 ins. apart. After you have marked the canvas, take old rope, spread it out, and cut the strands into pieces 4 ins. long. These pieces are called "thumbings." Fray both ends of these thumbings and you are ready to start sewing. Use a heavy sail or sack needle and sew these thumbings through the middle to the canvas, using the "back-stitch."

When sewing, follow the lines on the canvas and sew the thumbings close; draw your thread tight. When you have finished you will have a door mat that will clean dirty or muddy shoes better than any mat on the market and it will last longer.

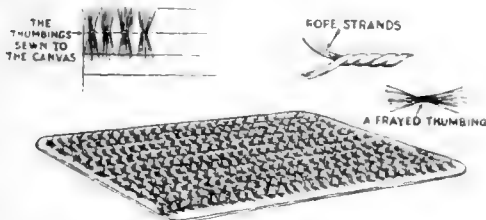

Old rope-ends are useful in making a durable mat for the outside door

A Back-Saving Refrigerator

AN unusual idea has been carried out in a new home in Iowa, where the housewife believes in having kitchen storage places as near as possible to waist-height, to prevent wearisome stooping or stretching. Not only the utensil and china cupboards, but also the built-

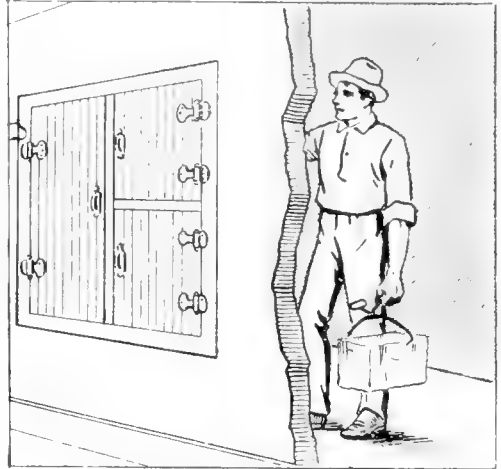

Ice can be admitted through outside doors with no inconvenience

in refrigerator is located above the floor. This refrigerator is set into the kitchen wall and is iced from the back entry. Its base is about 30 ins. from the floor. The convenience of the iceman, who must lift the ice, is served by steps in the outside hall.—A. G. VESTAL.

Renovating the Lawn

THE most effective way to renovate the old lawn is to make a new one. In most cases it will not pay to attempt to patch a poor grass plot for the difficulty probably is due to lack of proper soil conditions, and these cannot be satisfactorily remedied without an entire remaking of the lawn.

If the lawn is on a good soil and is merely disfigured with weeds, it can be brought into satisfactory condition by scratching the surface with a rake after removing the weeds, and seeding with well cleaned seed, using about one-half as much as for a new seeding. Bone meal, a complete commercial fertilizer and nitrate of soda may then be added with satisfactory results.

# Weightmobile Approaches Perpetual Motion

A VEHICLE body mounted on springs has a constant vertical movement, the amplitude of the motion being dependent on two things: first, the speed of the vehicle, and, second, the inequalities of the road. The weightmobile is a piece of mechanism designed to convert oscillations into a continuous rectilinear movement, and thus greatly assist in propelling any moving body on wheels.

The manner in which this is brought about is shown in the accompanying drawings, which illustrate the power as applied to a boy's push-cart. Fig. 1 is a side view; Fig. 2 is a top view; Fig. 3 is a side view of one of the disks which is attached to the hub of the vehicle, and Fig. 4 is a cross-section of the disk, revealing its interior construction.

The little push-carts, as now made, comprise the front and rear wheels and body. It is not necessary to make any changes in these elements. The additions required are to provide the hub of the rear wheel with one of the disks at each end of the hub. The disk in Figs. 3 and 4 consists of a central aperture which permits it to be

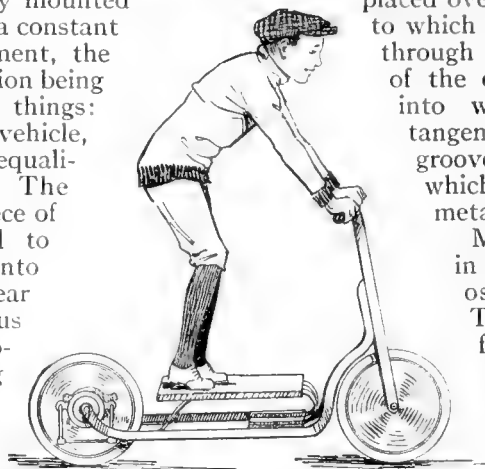

Every bit of energy is used to propel the push-cart

placed over the end of the hub, to which it is secured by bolts through holes. The perimeter of the disk has a wide rim into which are cut four tangentially-disposed cross-grooves, or slots, each of which is provided with a metal roller.

Mounted on the frame in Figs. 1 and 2 is an oscillating platform. This is secured to the frame by means of two U-shaped springs, enabling its rear end to move up and down a limited distance. A pair of flat springs is secured to the

lower side of the platform, and their rear ends project back to points directly above the arms of the respective disks on the rear hub. The arm of one disk projects to the front, while the arm of the other points to the rear. Links between the ends of the flat springs and

two disk-arms provide a means for imparting the oscillating motion of the platform to the arms of the disks.

The tendency of bouncing up and down produces an oscillating motion which is applied to the disks in such a manner that the vehicle is propelled whether the platform moves up or down.

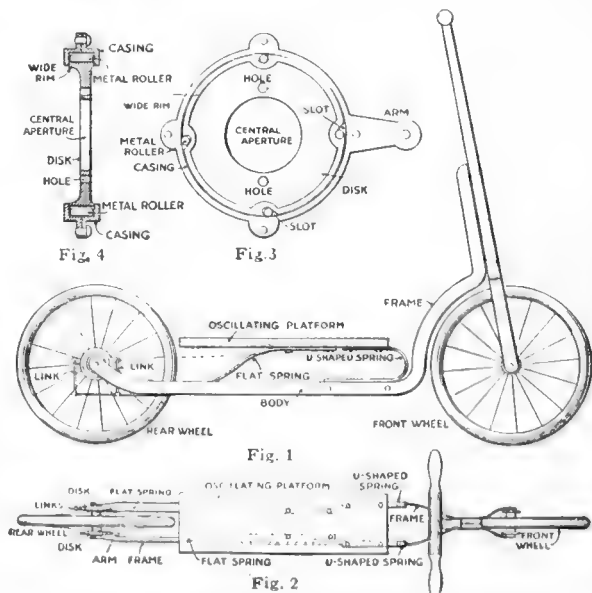

Diagrams of construction details of the weightmobile

# Trend of Motor-Truck Design Toward Worm Drive

**M**ORE than sixty per cent of the American motor-trucks listed on the market at the present time are worm-driven. Last year twenty-two per cent of the trucks listed were worm-driven, thus showing that the popularity of this form of drive has increased.

To understand the reason for this great increase, one must first know the cause for any form of gearing for transferring the power of the truck motor to the rear wheels in order to make the truck move. The average gasoline motor of the truck of today revolves at the rate of from 1,000 to 2,000 revolutions per minute. It is out of the question for the rear wheels to revolve at any such speed because they would simply spin around and not secure enough traction between the tires and the ground to make the vehicle move. The necessary reduction between the speed of the motor and that of the wheels under varying conditions of roads is secured through some form of change-speed mechanism and the form of gearing used between the motor-shaft extended and the axle of the driving-wheels.

The latter type of gearing may be divided into four main classes as shown

in the accompanying illustration, although there are some few other types used on special vehicles. The four most common types are: 1, Bevel drive; 2, Worm drive; 3, Double-chain drive, and 4, Internal-gear drive.

In the bevel drive the power of the motor is transmitted through the clutch

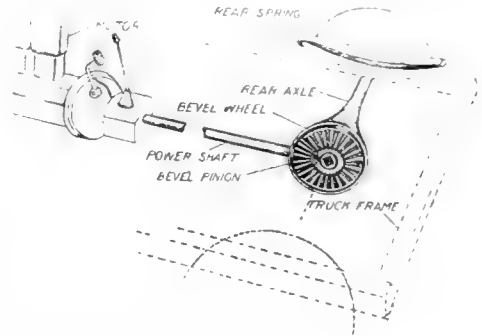

Fig. 1. Bevel drive. The bevel-pinion on the end of the shaft meshes with a large bevel-wheel in the rear

and change-gear mechanism to a longitudinal shaft at the rear end of which there is mounted a bevel-pinion. This meshes with a larger bevel-wheel to which are connected the ends of the rear wheel axles. When the bevel-pinion is made to revolve, the bevel-wheel revolves, which in turn sets the wheels in motion and causes the vehicle to move. This construction is shown in Fig. 1.

The method of worm drive shown in No. 2 is exactly the same except that a worm-gear and worm-wheel are used instead of a bevel-pinion and wheel.

The double-chain-drive method is based upon the same principle as the former methods except that instead of the extended motor-shaft reaching the rear axle of the truck, it ends at a rear-axle unit or jackshaft attached to the frame forward of a stationary axle on which the rear wheels are mounted. The jackshaft is the same as the rear-axle unit shown in No. 1 except that instead of having wheels mounted on the ends of its shaft, it has sprockets. Endless chains are passed around these sprockets

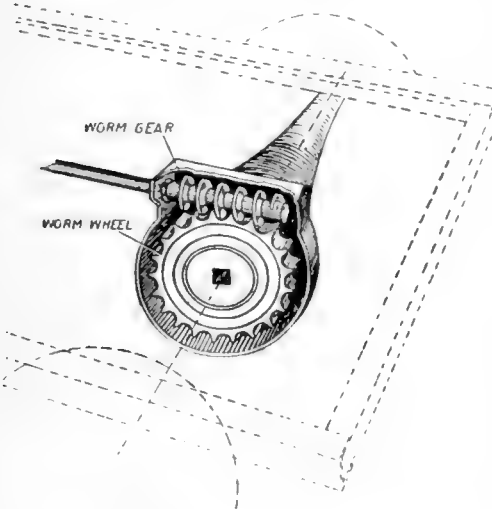

Fig. 2. Worm drive. The bevel-pinion and wheel are substituted by a worm-gear and worm-wheel

to two other larger sprockets, one bolted to each of the rear wheels of the truck. The motor power is thus transmitted to the jackshaft, to the jackshaft sprockets and thence through the chains to the rear wheel sprockets.

The internal-gear drive method shown in No. 4 also employs a jackshaft but this, instead of being mounted on the truck frame, is made into a unit with a stationary axle carrying the rear wheels. The wheels are revolved through small pinions positioned on the ends of the jackshaft which mesh with large internal gears bolted to the rear wheel spokes.

The bevel drive is used mostly on trucks of one-ton capacity and under. It is not used on larger trucks because the greater gear reduction necessary due to the greater weight of the truck and its load would make the bevel-pinion too small or the bevel-wheel too large for practical purposes. This necessarily larger gear reduction is secured by means of the double-chain drive by making the driving-wheel sprockets much larger than those on the jackshaft.

On the other hand, the necessary gear reduction for larger than one-ton trucks can be secured by means of the worm and worm-wheel due to the design of the worm-teeth and its rubbing instead of rolling action on the worm-wheel. It is also more efficient than the bevel or double-chain methods and delivers more power to the rear wheels because of the elimination of much of the friction of the

bevel-pinions and chains. It also has the advantage over the double-chain method in being an enclosed drive, like the internal-gear type, thus preventing dirt and grit getting on to the driving members, and causing loss of power and excessive wear.

Another advantage of the worm drive over both the chain and internal-gear types is that the aggregate parts weigh less than either. This lightens the truck, permitting more of the motor power to

be used for hauling the load to be carried instead of moving the heavy vehicle itself.

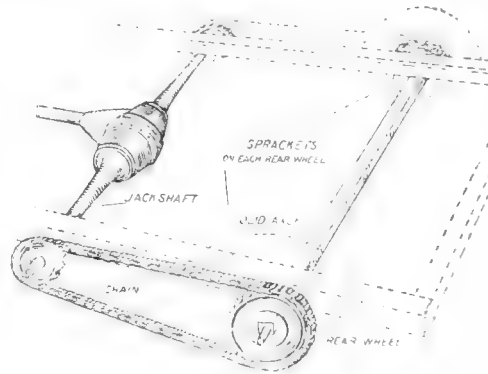

Fig. 3. Double-chain drive. The motor-shaft ends in a jackshaft which transmits the power to sprockets connected by chains

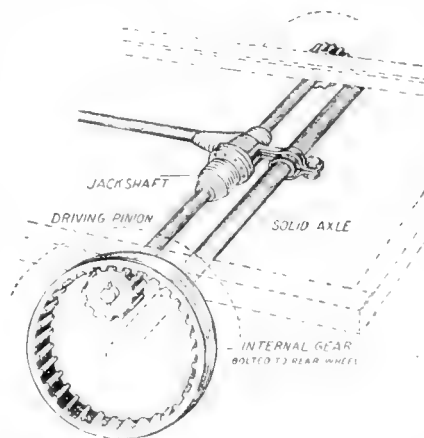

Fig. 4. Internal-gear drive. A jackshaft pinions with two large meshed wheels on the back axle

#### Measuring Rainfall on the Farm

**A**N excellent equipment for collecting and measuring either rain or snow consists of a simple pail or bucket. The location selected for setting out the pail should be in some open lot or field unobstructed by large trees or buildings. If the diameter of the pail is just  $10\frac{1}{2}$  ins. at the upper edge, each ounce of water collected represents 0.02 in. of rainfall. The pail should hold twelve quarts, in fact, most twelve-quart pails are exactly  $10\frac{1}{2}$  ins. at their upper edge. The depth of the rainfall, as shown by the water caught, may be found by weighing the contents of the pail. An ordinary small balance which reads in ounces and half-ounces is suitable for the purpose. In hot weather, when water evaporates quickly, the record should be made as soon as the rain has stopped, if possible.

# We Paid Six Dollars

## For These Two Pictures

**O**F course you recognize Delia, the motor duck, which appeared in our March issue.

We want more photographs of equally interesting inventions, and we will pay for them at the rate of \$3.00 each. The more daring the invention, the better for us.

### But, Let the Picture Be Alive

Let a man or a woman appear in it doing something useful in connection with the machine. Dead machinery is not interesting.

Look about you for curious applications of old machinery. The automobile, for instance, is used for many purposes.

### Things You Can Do with an Automobile

We know of one very resourceful man who uses an automobile to control a captive balloon. He simply jacks up the rear wheel and connects the axle with a winch. We know of another man who once lit up a church with his electric car in an emergency.

And we know of a third who ran a whole printing press with an automobile when the steam engine of the plant broke down.

Whether it is a telephone, a

threshing machine, a safety razor or a grand piano, send us a picture of it if the device is doing something unusual.

### Queer Ways of Making a Living

By the way, we are getting up a collection of photographs to be published under the general title "Queer Ways of Making a Living." Perhaps you would like to contribute some snapshots to the collection.—THE EDITOR.

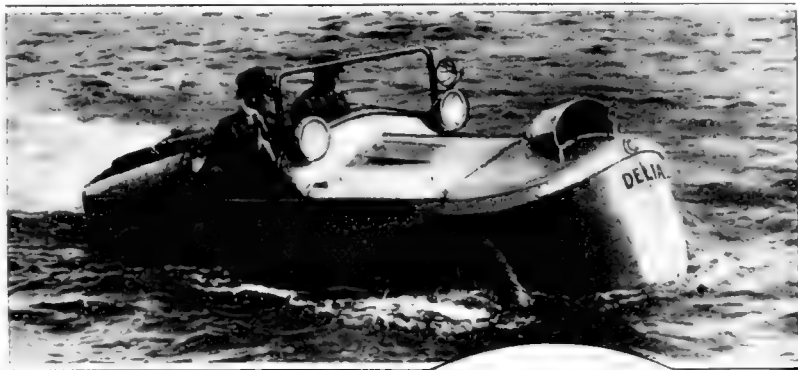

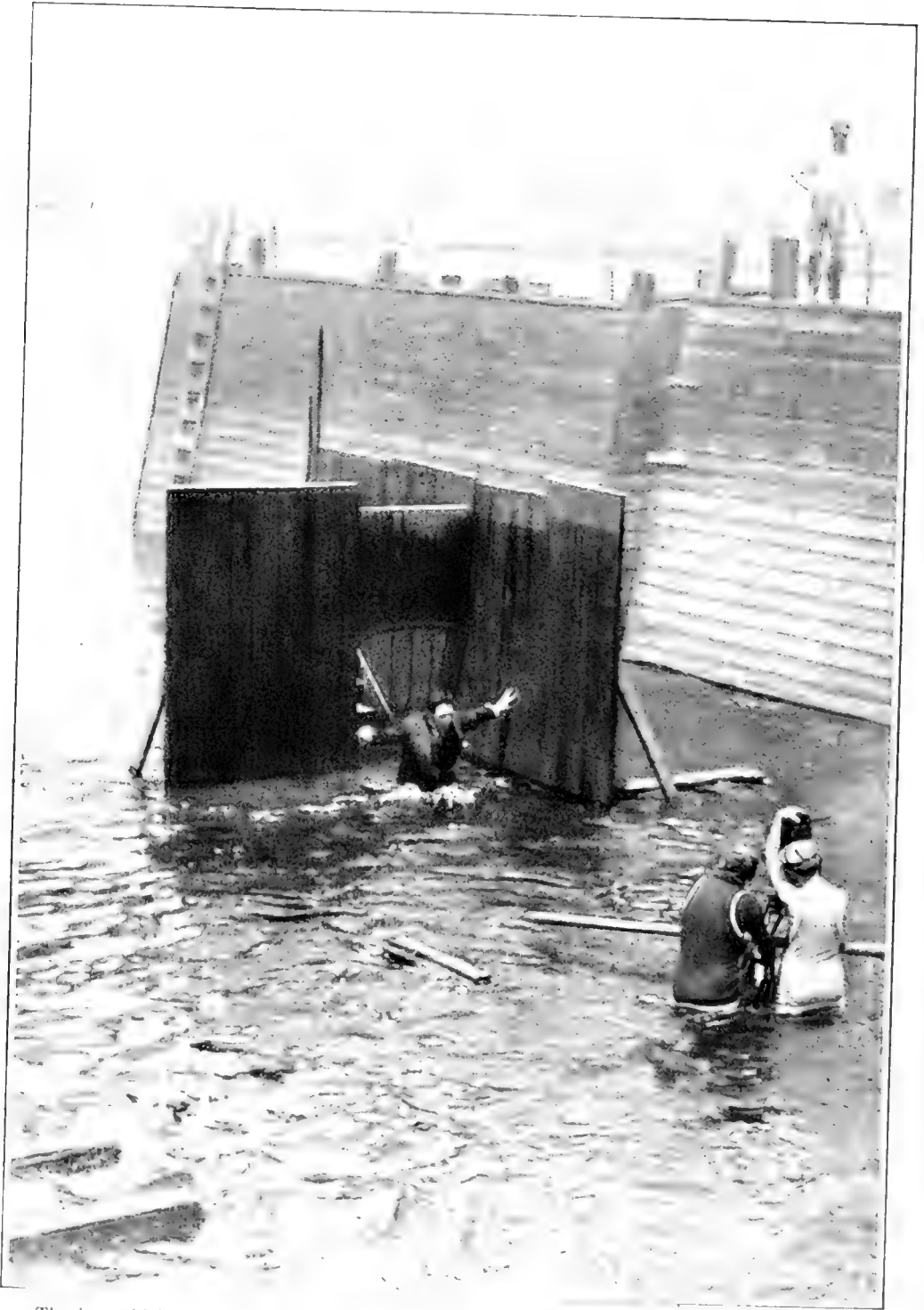

The intrepid hero comes downstairs just off the Jersey shore and finds the Hudson River wallowing in his reception parlor. Fearlessly, at the command of the director, he jumps in the water and ploughs knee-deep through Hoboken mud while the camera clicks

# Popular Science Monthly

239 Fourth Ave., New York

Vol. 89  
No. 2

August, 1916

\$1.50  
Annually

## Catastrophes by the Foot

**T**O paraphrase the words of a well-known humorist, there is motion-picture realism and, on the other hand, there is motion-picture realism. There is cinema realism which consists mainly in cheap and unconvincing illusions. Into this class falls the director who substitutes a miniature dreadnought in a bathtub for the real article, or the director who mounts his camera on a rolling platform, this device giving to the steady deck of a ship the appearance of rolling and tossing. On the other hand there is the director who will command his players to leap real precipices on horseback. He is the same director who will sink a company of players with

a stretch of nailed-down scenery on a floating dry-dock. This type of director is the man who is giving the public its most shivery thrills.

Sinking a "set" on a floating dry-dock has been done more than once. In fact, it is a favorite trick. A stateroom of a ship is built of wood strips, painted canvas and a porthole. It is erected on the platform of a floating dry-dock and the camera adjusted. The action, dramatically speaking, starts. The sea-cocks of the dock are opened and it gradually sinks. Water creeps up—the ship is sinking! The cameraman cranks, the actors go through all of the pantomimics necessary to convey the alarming information that the ship is



Would you care to be a motion-picture operator or a motion-picture actor, after this? Would you look brazenly out of the picture and care naught for the opinion of the man on the wharf?

foundering. When the water is lapping the handsome chin of the hero and the heroine is getting the life preservers from under the berth—the director shouts, "Cut!" When the scene on the screen shifts from this to a real ship tossing about in a storm, the illusion is vivid and convincing.

But action for the director and the actors doesn't stop here. In addition to having the whole Atlantic Ocean dumped into his parlor just as the clock strikes noon, the poor rich

The present widespread interest in warfare has occasioned the building of elaborate paraphernalia for making motion-pictures

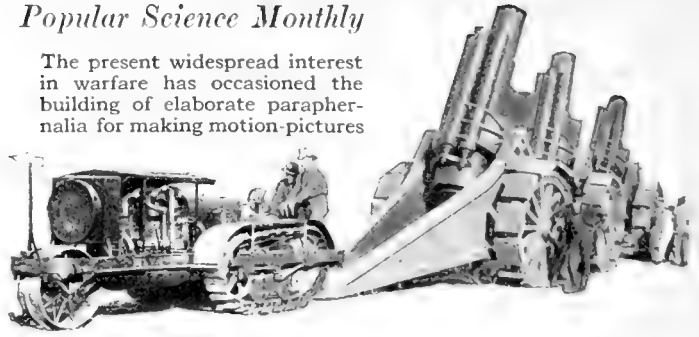

attempt in imitating the 12-inch siege howitzers employed by the Germans. The huge guns are constructed almost entirely of wood which is supplemented at all wearing points with metal. The guns follow the well known Krupp design faithfully. A recoil mechanism is provided as well as a means for regulating the angle of the gun barrel. The wheels are provided with caterpillar treads to enable them to climb over rough ground. The powder charge used in firing is mixed carefully in the studio laboratory. In making the picture the guns are drawn from the point on the "firing line" by a tractor driven by a gasoline engine.



The camera man, under the umbrella on the platform, is busily filming the wooden Krupps as they are Krupping away at the invisible enemy

actor dons his summer tweed ten minutes later and hurries to another part of town to take part in a staged battle, or "war stuff."

Here the directors are compelled to resort to whatever alternatives stage carpenters and studio mechanics can devise. One of the latest of these invasions into carpenter shop realism is a successful



All that glitters is not gold; all guns are not of steel. These are of wood—perfect imitations of the famous Krupp howitzers



### Revolving Portable Elevator

**L**ADING barrels, cotton bales and crates with the aid of a revolving portable elevator, which has just been placed on the market, has enabled the manufacturer to reduce labor costs and at the same time complete his task with a thoroughness heretofore impossible. The elevator covers a wide range of usefulness. Machines have been supplied for lifting corpses in morgues and for placing coffins in niches such as are used in South America. In fact, the machine can be used to pile anything at all.

Loading barrels into freight cars has been a difficult and hazardous undertaking. With the new elevator it is simple. In one instance a railroad company was spared the necessity of building a loaded platform all along its yard siding. The barrels were rolled upon the elevator platform from two planks, on one of which an operator stood. The platform was then cranked up to the desired height, and the upper base swung around ninety degrees on the turntable, which put the barrel into the proper position to be rolled off on the car floor.

In one instance the elevator piled crated gas-engines inside a box-car, and piled them so compactly that the manufacturer is now able to take about thirty per cent more of his gas-engines in one car-load than he could handle

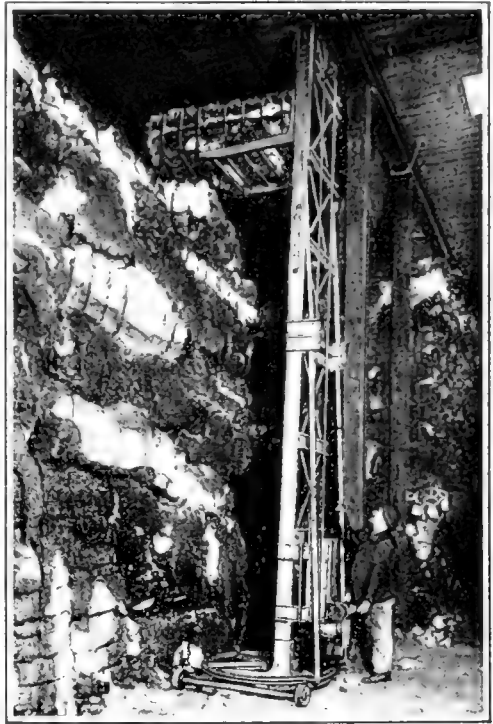

As the stack grows the elevator is adjusted to the new height

before he obtained the revolving portable elevator. In warehouses bales of cotton can be piled, neatly and squarely, in stacks up to twenty feet high. In stacking barrels of oil the machine is especially valuable. The barrel is pushed on the elevator platform, the operator cranks up the machine to raise the platform to the desired height, and when the platform reaches it, he swings the upper structure around and simply rolls off the barrel on to the skids.

To enable the machines to be taken through low doorways from one room to another they are provided with hinges in the uprights at a point six feet, six inches from the floor. The hand-operated machines are provided with a patented safety-hoist which makes it absolutely impossible for the operator to be hurt by a flying crank.

Not only does this machine do its work quickly and without danger, but its operation is not costly, since one man can run it easily. Furthermore, much space is saved by packing articles closely.



Loading barrels into freight cars is simplified by this portable elevator

### Modern Methods for Exterminating the Mosquito Pest

**N**EXT to draining, the best way to abolish mosquito breeding places is to treat the water so as to kill the mosquito larvae. While many substances have been tried for this purpose, nothing has given such good results as petroleum, according to experts of the United States Department of Agriculture. Common kerosene of low grade is most satisfactory as regards efficiency and price.

It has been found that spraying with a portable pump is the best way to use the oil. Small ponds, however, can be sprinkled out of an ordinary watering-pot with a hose nozzle, or for that matter pouring it out of a dipper or cup will be satisfactory. In larger ponds pumps with a straight nozzle may be used. A straight stream will sink and then rise and the oil will spread until the whole surface of the water can be covered without waste.

In choosing the grade of oil to be used two factors must be considered; it should spread rapidly and should not evaporate too quickly. Heavier grades of oil will cling together in spots and the coating will be necessarily thick. It has been found that one ounce of kerosene is sufficient to cover fifteen square feet of surface, and in the absence of wind, such a film will remain persistent for ten days. Even after the iridescent scum apparently disappears there is still an odor of kerosene about the water. A mixture of crude oil and kerosene has been found to be effective in killing mosquito larvae. It has one advantage over pure kerosene in that it does not evaporate so quickly.

Special attention should be paid to little pockets of water that form around the edges of ponds, for it is in such places where the water is not disturbed by wind or otherwise that the larvae breed in greatest numbers. Larvae do not breed in open stretches of water where the surface is rippled by the wind.

In the fight against the mosquito in Panama, the government experts found that a larvicide composed of carbolic acid, rosin and caustic soda was very effective and thousands of gallons of it were used.

### Threshing by Night Under Electric Light

**T**HE farmer like the city man does not allow daylight to put a quietus on work. On the other hand he labors into the night just as assiduously as the city man, and makes hay not only while the sun shines on this side of the earth, but while the sun shines on the other side, too. With the aid of a new portable generator recently placed on the market he can do his threshing at night, and do it with a degree of thoroughness not excelled in the brightest sunlight.

The dynamo is drawn up beside the thresher and is driven by a belt from the threshing machine. The apparatus is sufficiently powerful to light at least one arc light, which throws a brilliant white light on the field of operations. When the farmer finds the spring thawing season suddenly thrust upon him and the ground ready to be plowed he can work far into the night with the aid of the same portable generator. It supplies light for two projecting lamps, one in front to light the way, and the other in the rear to show the plowed area.

### Uncle Sam Says Miraculous Wheats Are an Old Delusion

**T**HE notion that there is a wonderful wheat which will make the fortune of anyone who plants it seems to be almost as old as agriculture itself. In this country, at least, such an assertion was made for the so-called Jerusalem wheat as early as 1807, and, under the name of Alaska wheat, this identical variety is still being pushed upon the unwary at exorbitant prices for seed. Almost equally exaggerated claims are made for the Stoner variety, but this particular wheat has not such a long history.

Because of the many attempts that have been made by promoters to foist these wheats, under one name or another, upon the farmers of the country, the Department of Agriculture has made careful tests of their value. The results of these tests are said to show conclusively that neither of the wheats possesses any peculiar quality which justifies high prices for the seed. Many varieties grown commercially throughout the country have proved to be superior to either the Alaska or the Stoner.

## Where the Modern Farmer Spends His Evenings

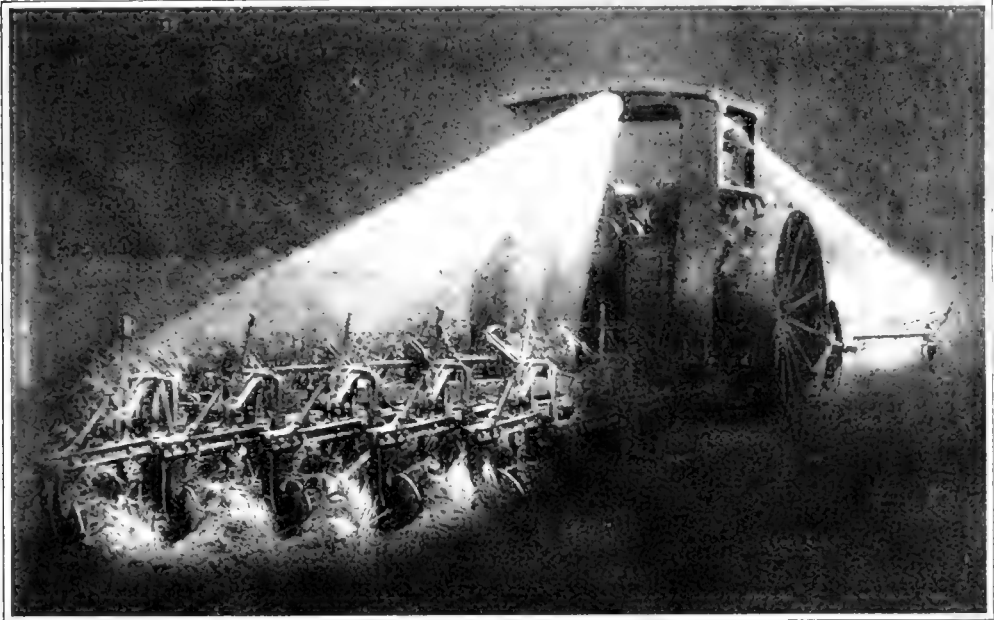

Plowing a field at night with the aid of two powerful lights which enable the operator to see the path ahead of the machine he is driving, and the width of plowed field in its wake



Threshing after sunset. The arc light derives its current from a dynamo which is belt-driven from the threshing machine. In this way the farmer makes hay while the electric light shines.

## Leaping Horses That Are Unafraid



Though horses usually hesitate to jump over obstacles near human beings, the horse of a United States Army lieutenant jumped over a mess table surrounded by soldiers. He showed no hesitation, and did not upset even the bottle of sauce or pitcher of coffee on the table though they were dangerously near the flight of his heels



At right, a feat of horsemanship not without an element of danger to both horse and rider. The illustration below shows "Rabbit," a privately-owned horse of Washington, D. C., hurdling a high-powered racer without making a scratch in its white hood

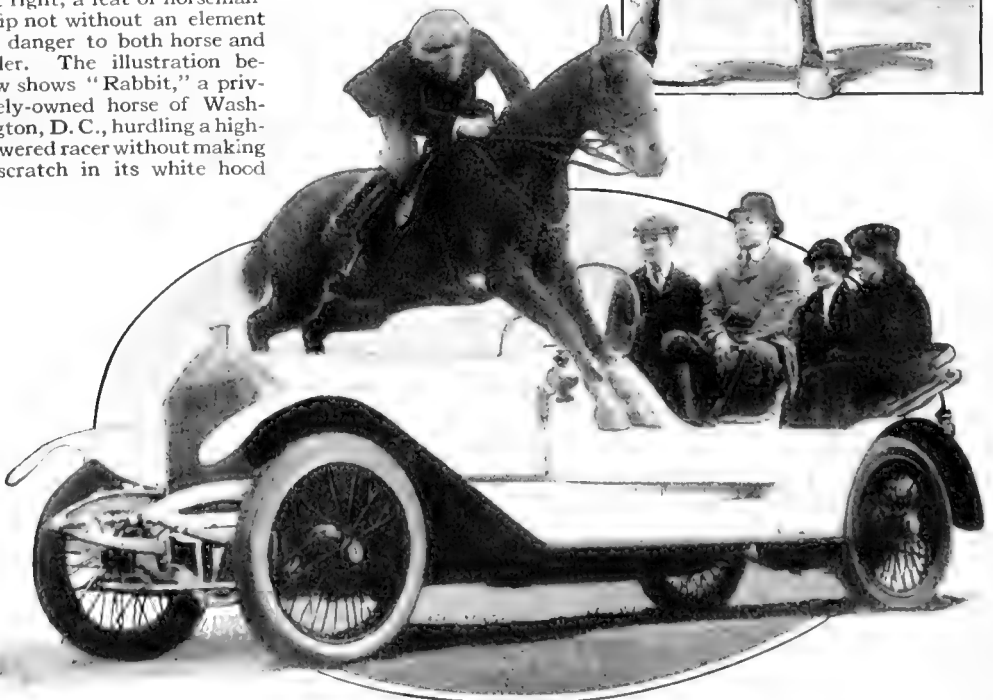

# Minute Men of the Rails

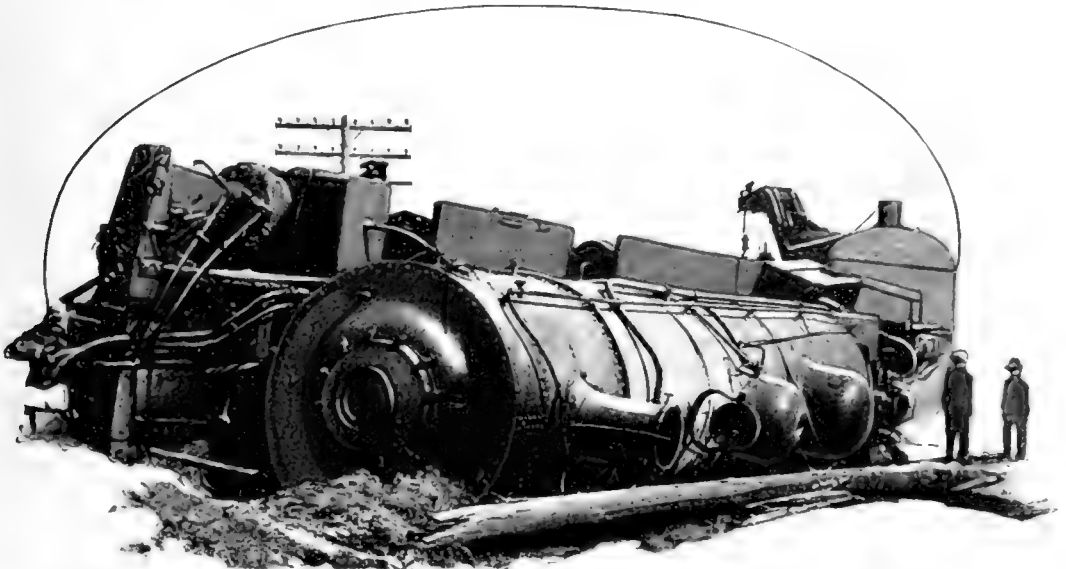

Much of the fascination of railroading centers around the wrecking crew and the important and oftentimes gruesome work of clearing wreckage and keeping the lines open

**W**RECKING-TRAINS are located on every division of important railroads, standing idle in the yard, waiting for calamity. . . A crane-car, with sufficient power to lift a freight-car as a child lifts a toy; a supply-car, containing rope, cables, chains, jacks, crow-bars, tools, lanterns, fire apparatus, dynamite, rails, ties; a caboose for the wrecking-crew.

When the word comes over the wire that the express and the fast freight have tried to see which could butt the other off the track, the wrecking-crew assembles in a hurry. They are picked men—these minute men of the rails—each with his specialty. Mechanics, track-men, men skilled in explosives, strong men, slender men, at least one small but muscular man, they come from roundhouse and shop, freight yard and office, at the supreme call. The wrecking-boss takes command, the best engine available backs down, and with a clear track the wrecking-train gets to the disaster, often ahead of the special containing doctors and nurses.

There is only one order to be obeyed when the wrecking-crew gets in action—

“Save life.” But once the victims are extricated—and they are taken out in a remarkably short time—the order changes. It is not, as might be expected, “Save property.” It is “Clear the lines.” It makes no difference that five jumbled freight-cars contain expensive automobiles, or pianos, or phonographs, or fruit, which might be saved by careful work. If the contents cannot be saved in less than an hour, there is only one thing to do. The big steam crane is backed down to the mess, a long, tentacle-like hook descends, chains and ropes are brought into play, and slowly, surely, almost daintily, the crane swings the wrecked freight-car and its contents to one side.

Sometimes the easiest way to clear the lines is to burn the wreck or blow it up. Track can be quickly relaid, if damaged, but nothing can replace lost time. The price of a cargo of automobiles is nothing against a five-hour delay. For the price of delay mounts in stunning geometrical progression. A few hundred dollars for the first hour, it may be many thousands of dollars in the second or third hour. A stoppage

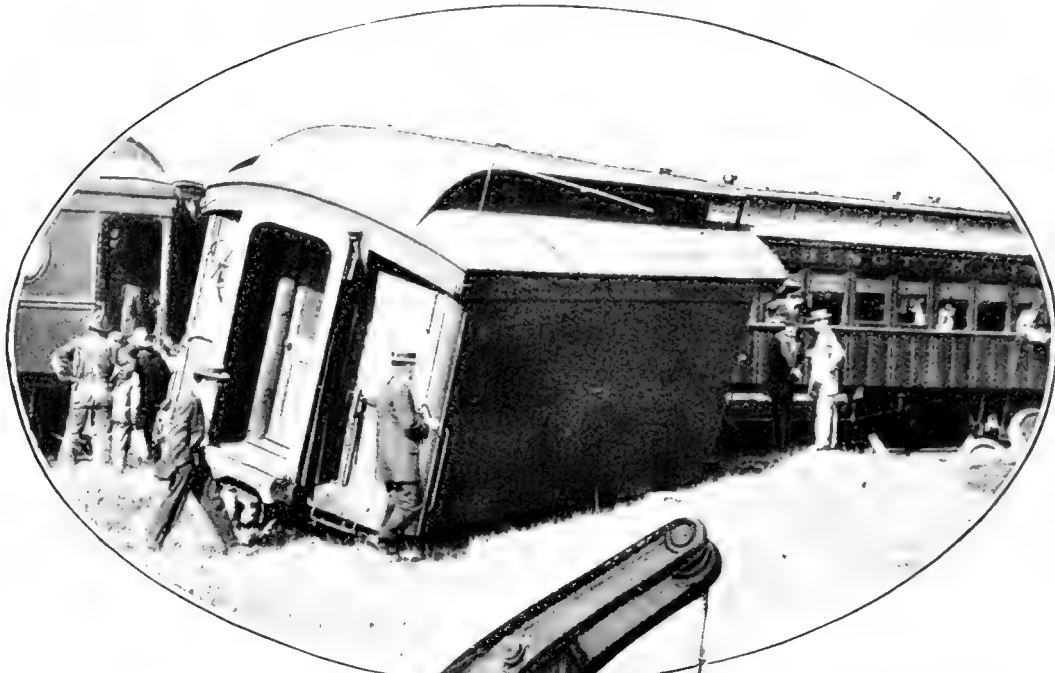

A wooden coach stands at one side cut in two as if with a giant saw. Behind it stands an impatient express and behind that a long freight train. In the other direction a local is filled with fuming commuters and perhaps the President's special is close behind. All along the division and soon to spread through the whole system is delay, stalled trains, trains waiting orders, trains costing the railroad company thousands of dollars a minute to operate

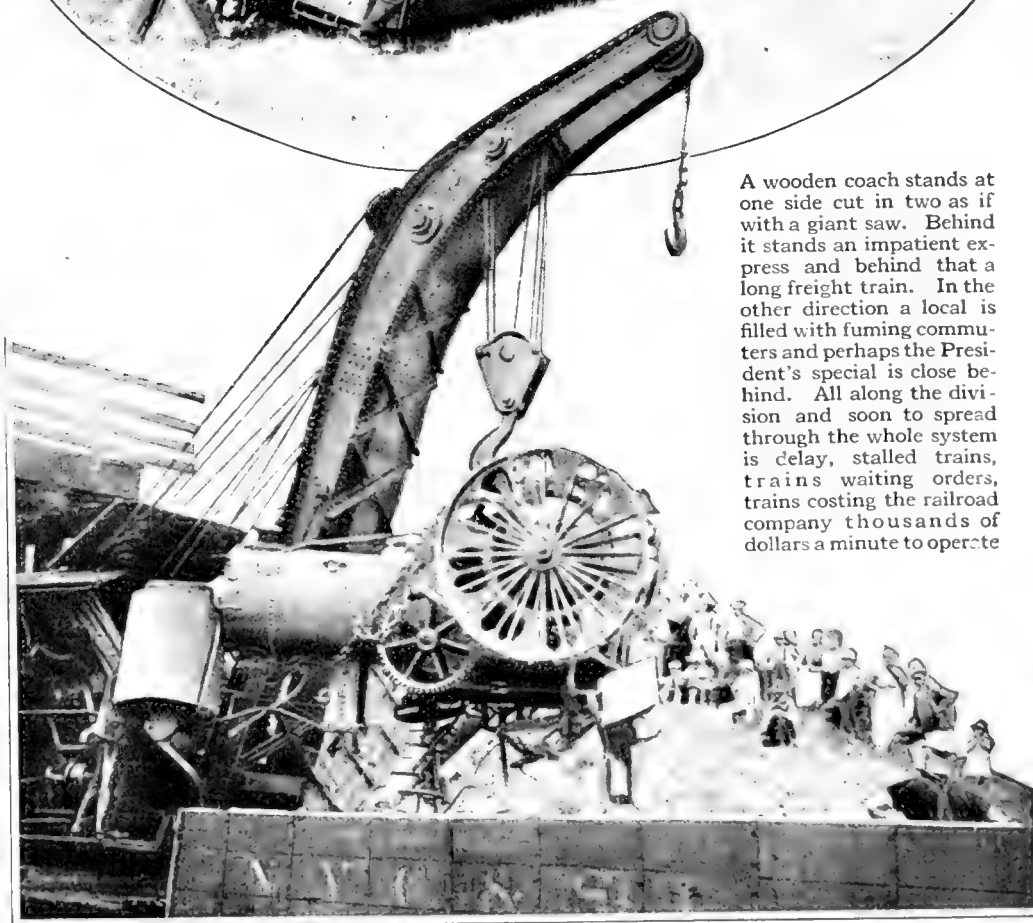

The crane can pick up and transplant five tons of twisted steel as easily as a nurse can lift a baby from a perambulator. When the great tentacle like hook descends, chains and ropes are brought into play, and slowly, surely, almost daintily, the crane swings the wreck to one side. If it cannot be lifted it is burned or blown up. The price of a cargo of automobiles is nothing compared with a five-hour delay or the disruption of a railroad's train schedule



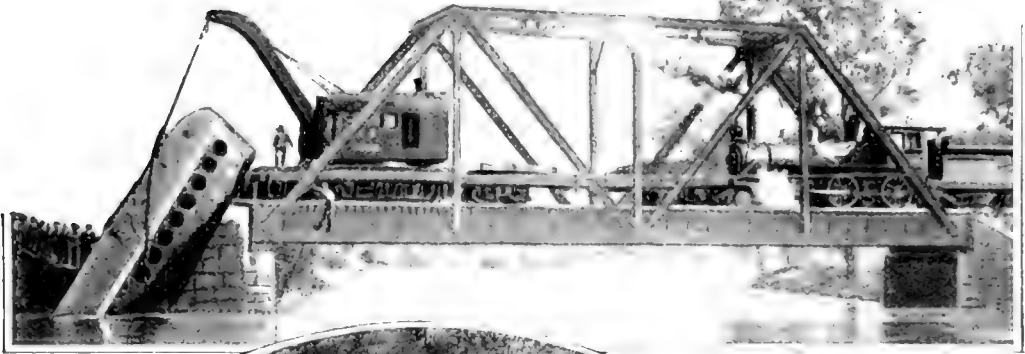

Above, the crane has its "hands full," but fortunately for it the car is of steel and can stand the heaviest pull

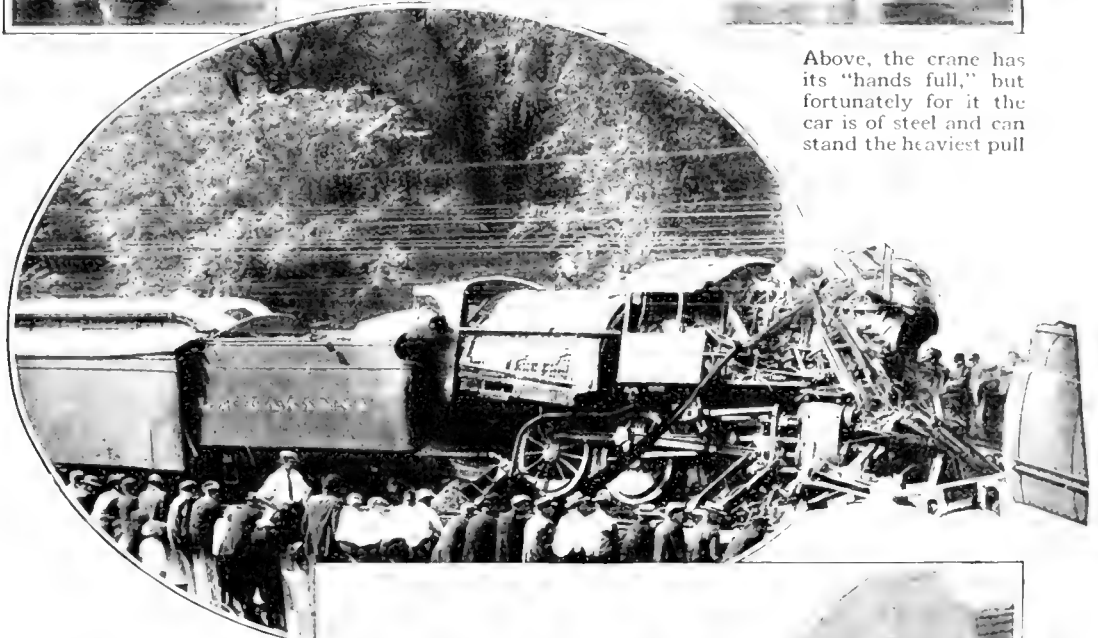

Above, a locomotive with a ruined "face." Such wrecks almost always cost human life

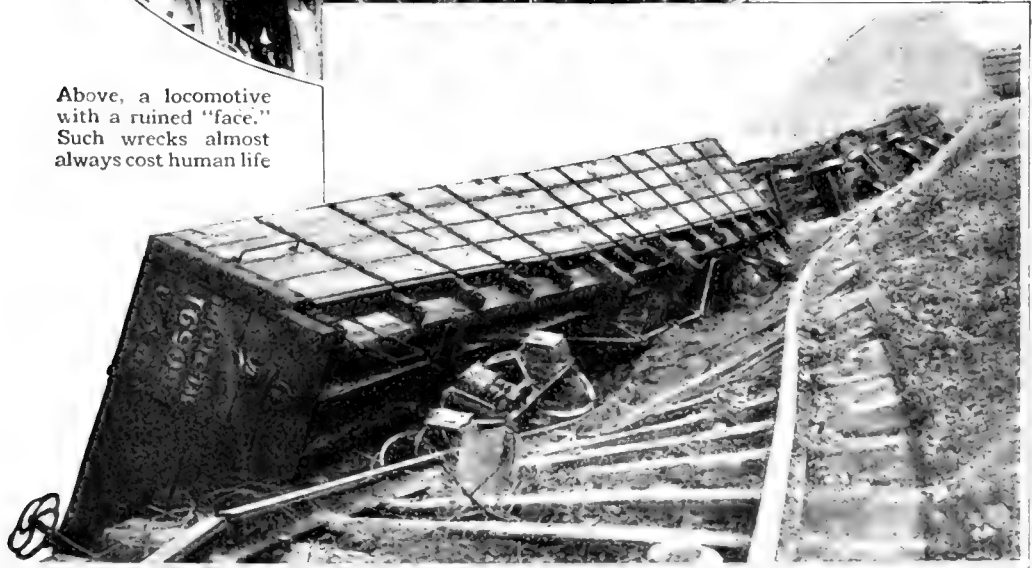

A slip and slide into the river is all that happened here, but it took a complete track laying gang in addition to the wrecking-crew to get the line open again and restore train schedules



The wreck occurred a considerable distance from this bridge but the threshing machine, mounted on a flat car, was hurled with such force that it struck the bridge and broke through

The doctors and the nurses and the relief-train have come and gone; down the line stands an impatient express, behind it a long freight. In the other direction, a local is filled with fuming commuters and perhaps the President's special is close behind. All along

the division, and soon to spread through the whole system, is delay, stalled trains, trains waiting orders, trains costing the company thousands of dollars a minute.

Over the tangled debris one man stands supreme, snapping his orders like the crack of a whip, utterly unmindful of the property he destroys that other property may move. And, as if by magic, the lines clear. The last of the bent and broken cars are turned on their sides and slid down the bank. The injured engine limps off behind a fussy switch-engine sent for the purpose. If the delay looks long, a temporary side-track has been swiftly built and the several waiting trains puff slowly by. The wrecking-train whistles. Its crew, driving the last spike to make the injured track secure, pull out jimmy-pipes. The big crane folds its single arm and rests. The men pile into their caboose. The wreck is off the lines—time, fifty-five minutes. The wrecking-train has finished its work.

of the lines may mean a stoppage of the whole railway system, with hundreds of thousands of dollars worth of freight tied up, confusion, loss, waste.

And well he knows his work. The crane for this car, the jacks for that. This engine looks like scrap but will probably run; put her on the other track. That engine looks all right but is vitally wounded; throw her off. This car is too inextricably tangled with another in loving embrace to take to pieces, part by part; burn it up and throw the trucks to one side. The small man, a necessary factor, crawls into and out of openings and holes too small for his stronger mates, attaching chains and ropes, reporting conditions, doing work as valuable as that of the Hercules who, with a crowbar, heaves up a tangle of wheels that a jack may be slipped into position.



How the Porto Rican Does a Pushing Business

An Air-Propelled Automobile for Three Dollars

THE colored merchant of Porto Rico shown in this photograph may literally be said to do a "pushing business," for his stock in trade as well as his store itself is on wheels and is pushed about by the owner. Rent troubles this man not at all. If competition becomes too great in one spot he can readily seek a new location to solicit trade and he can go to his customers instead of his customers being obliged to come to him.

These quaint and curious stores on wheels are everywhere to be met with in Porto Rico. One sees them about the streets of San Juan and Ponce, in the suburbs of Santurce and Miramar they are legion, and one meets them along all the splendid automobile roads that stretch across the mountains and plains of the island. Even in the smallest and most remote villages and mountain towns the natives carry on their "pushing business" methods. The odd custom has much to recommend it aside from its picturesque and unusual aspects. The goods within—usually confections, cakes or other edibles—are carefully protected from flies, insects and dust. In a tropical climate this is of vast importance and in a country where sanitation is as strictly enforced as in Porto Rico it is entirely in keeping with the spirit of the people.

Many of the stores on wheels are very elaborate and ornamental, others show great ingenuity in their construction while still others are marvelous in their quaint architecture and gaudy colors. Some, like the one illustrated, are in the form of miniature buildings, others are in the shape of steamships or war vessels; others are fashioned like little trolley cars while some resemble nothing on the earth, in the heavens above or the waters beneath.



While his wife is wheeling the baby the Porto Rican is wheeling his business

AT an expense of three dollars Meredith Coates of Kansas City, Missouri, built an air-propelled automobile which ran at a speed of twenty-two miles an hour along a smooth road. The

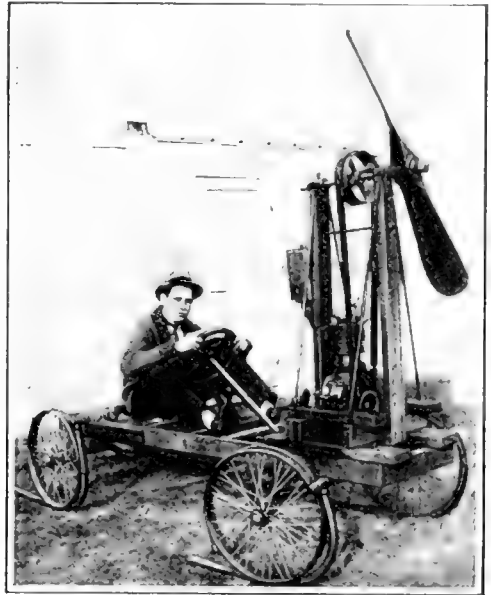

This machine can go as fast on ice as on land. The only thing it can't do is fly

engine is a five-horsepower motor-cycle engine and it was bought for one dollar. The propeller was made from wood at a cost of another dollar and the last dollar was spent in making the gas-tank, boxings, steering-wheel, frame, shafts, pulleys and belt.

The apparatus was originally tried out on a canoe and then shifted to a sled. The sled runners may be seen attached to the frame in the accompanying illustration. When the ice was gone the propeller mechanism was transferred to the cart frame. The machine has all the appearance of a racing automobile.

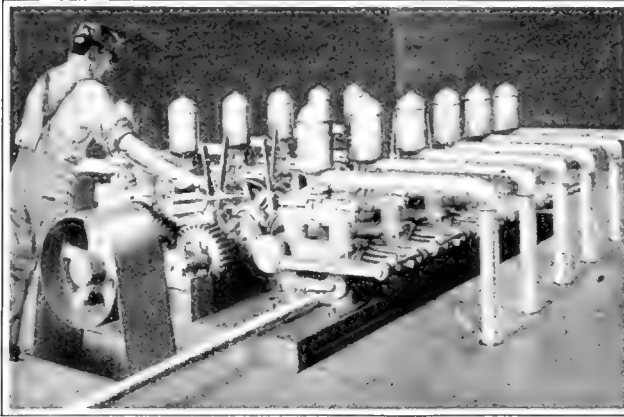

The twelve pumps terminating in one large mixing tank are illustrated above. Each pipe is connected with a separate tank and the object of the apparatus is to obtain an accurate blend of the twelve different grades of oils

### Blending Twelve Grades of Oil Into One

A PUMPING plant of a new kind has been constructed for a large oil company in the West to mix oils. There are twelve pumps, each of which is separately controlled by a clutch. Different grades of oils are required for various purposes, and it is the object of this equipment to supply the blends or mixtures of oils according to the formulas prepared by experts. Each of the twelve pumps is connected by a pipe with a different tank of oil, the main jet from all of them terminating in one large mixing tank.

### Another Baseball Game in Disguise

IF baseball, the great American game, fails to live up to its reputation with the coming generation it will at least not sink into oblivion. The large and varied collection of games simulating it will serve to immortalize it to future residents of this world, and the historians of a million years hence will make mention of the fact that numerous game sets left behind by us lead them to believe that as a race we were a people of low mentality, worshipping a game called baseball with as much fervor as the ancient Egyptians worshipped their graven images.

The most recent addition to the collection of games which might puzzle our

successors is an apparatus invented by a Massachusetts man. It has a game field provided with semi-conical catching-hoods arranged in the positions of the various players in the fields. These hoods serve to catch the ball and return it to a side pocket. There is a mechanical batter which swings a bat on a metal post set beside the home-plate. A spring operates the bat with considerable force.

The pitching device calls for real skill on the part of the player. The ball is pitched from a pivoted arm which has a ball-receiving cup at its upper end, and a notch in the rear of its base portion by which it is latched in retracted position. When the latch is released the pitching arm throws the ball toward the batter. The success of the player depends upon his ability to judge of the speed of the ball and then "bat" accordingly.

After considerable practice the player can sometimes "lift" a "high one" to center field or send a swift one bowling toward the shortstop position with such speed that it strikes the catching-hood with a resounding thud. This is one game where foul balls are unheard of. If the batted ball flies off at an angle the sides of the apparatus are high enough to prevent it leaving the board.

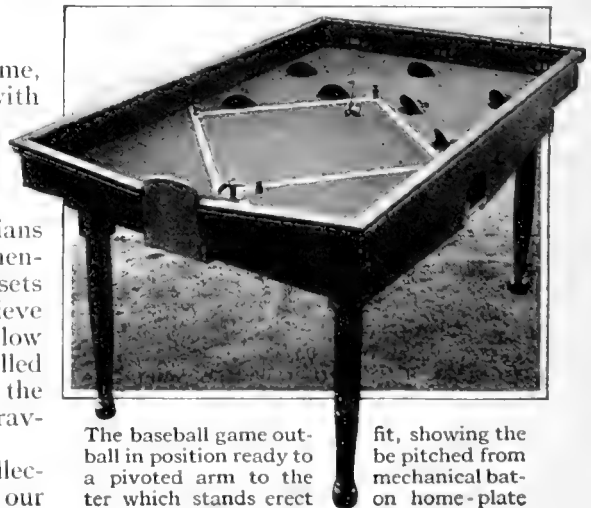

The baseball game out-ball in position ready to a pivoted arm to the ter which stands erect

fit, showing the be pitched from mechanical batter on home-plate

**A Perfect Megaphone Shaped Like a Ram's Horn**

**A**BOSTON physician, Dr. Edmund D. Spear, has invented a megaphone which is constructed on the theory that the original horn—the ram's horn—was and still is technically correct for sound reproduction. His megaphone is curved instead of the straight funnel-like shape of most other instruments, and one of the most interesting and useful features about it is the ability to use it without having it interfere with one's vision. Owing to the technical construction of the curved horn the volume of sound obtained is also much more satisfactory. In addition to this the tone is clearer and the enunciation more distinguishable. The best musical horns have the shape of a ram's horn.

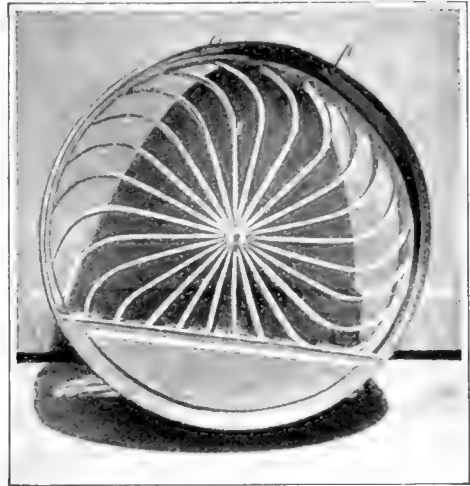

The ingenious water cooling and perfuming attachment for the electric fan

**Perfuming and Cooling the Air with an Electric Fan**

**A**CLEVER and useful attachment for the electric fan, designed by a Los Angeles inventor, consists of a tin wheel which can be hooked on any electric fan, and which will increase its cooling capacity many fold.

The spokes or propellers of this wheel are made of fine mesh screen. The lower part of the wheel whirls in a tank which is filled with cold water. The electric fan causes the screen propellers to revolve, and they dip into the little tank, throwing up a small amount of water on the upward turn.

The air is sent through the water and is cooled, purified and cleaned. Perfume, a disinfectant, or a medicated liquid may be used instead of water.

**Why the Gasoline Engine Keeps the Farmer Boy at Home**

**O**NE of the jobs on the farm, which has had as much to do in creating the desire of the farmer boy to leave and go to the city, has been the chore of sawing wood. It is one job that seemed never to be ended. With the advent of the gasoline engine, the work of sawing the wood, not only for farm consumption but for commercial purposes, has been changed to one of great fascination, if not pleasure, in comparison with its former drudgery.



The simple ram's horn is the original Adam of all our present-day megaphones

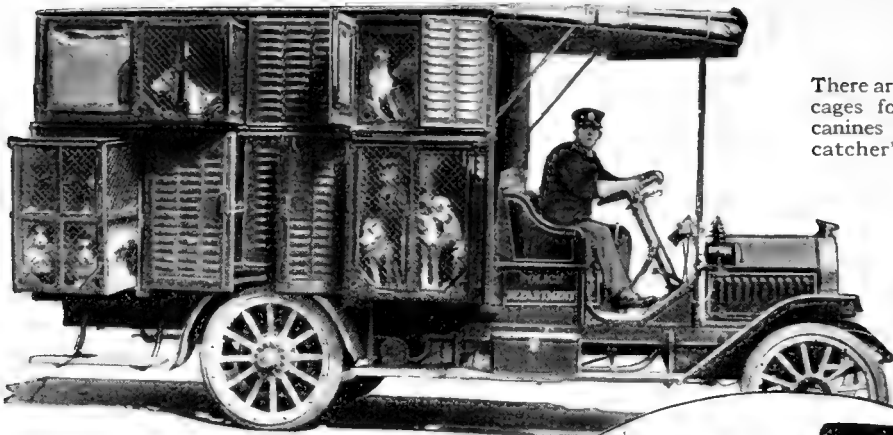

There are sixteen metal cages for all sizes of canines in this dog-catcher's automobile

Below, is shown the humane way in which a dog is caught by the wire net

### Modern Dog-Catchers Use Motor Trucks and Wire Nets

**K**EEPING pace with the times, even the modern dog-catcher now uses motor-trucks to collect stray animals and haul them quickly to the pound. One of the latest types of dog-catcher's trucks is shown in the accompanying illustration. It is used in one of the western cities and is equipped with an all-metal body for cleanliness. It is divided into eight compartments into which are slid sixteen metal cages to confine the dogs. The cages are pushed into place from both sides of the truck, meeting at the center. Four of the cages are subdivided into two parts each by horizontal partitions. These are used for the smaller animals while the remainder are employed for large dogs.

Each of the compartments has a shutter-door which protects the animals from the hot sun in the summer or snow in the winter and which gives them sufficient ventilation.

Motor-trucks have proven particularly adaptable for the dog-catcher because of the large growth of suburban territory about many of the big cities. This has necessitated longer hauls than horses could accomplish day in and day out through all kinds of weather.

Some dog-catchers prefer to use the wire net in catching the animals. This method is said to be far safer and surer than other methods in vogue, such as the wire noose and rope, both of which are more or less cruel. The catcher using



the net merely throws it over the dog; the animal becomes entangled and is then placed in the wagon without further trouble.

### The Cockroach Attracts Attention as a Trouble Maker

**R**ECENTLY while inspecting a large plant attention was called to a peculiar incident. On a branch circuit there was some peculiar trouble. Fuses would blow out at various intervals running from one-half hour to twenty-four hours.

At first no attention was paid, but when the ground detector started to show signs of trouble, first on one side and then the other, an investigation was made. Covers were removed from the outlet boxes and from one box a shower of live and dead cockroaches fell on the head of the examiner. On looking into the box, it was found that the insulation around the joints and especially at the points had been entirely eaten away, the vibration of the building doing the rest toward creating the trouble.

## The King of New York's Lighting Spectacles

**F**RAMED by the masonry portals of the Municipal Building the Woolworth tower by night represents one of the greatest artistic achievements in this age of electrical wonders. For more than a year now the thirty-storied tower has burst out into the night as a giant shaft crowned with a scintillating jewel. When that part of the building below the thirtieth floor is dark the tower takes on the appearance of a huge crystal hung by invisible wires from the skies. When the switches are pressed into sockets illuminating the structure more current is employed than is necessary to light the streets of a city of thirty thousand inhabitants. Six hundred automobile lamps are contained in the electrical installation.

The lights are so arranged that they flood every inch of the structure. An ingenious system of screening prevents the rays from shooting directly downward or upward, thus revealing the source of light. Anyone viewing the spectacle from below is vexed to find where the light comes from.

## Origin of Gas Jets Traced to Woman's Thimble

**A**WOMAN'S thimble is said to have been the means of suggesting the first gas burner. William Murdock, the inventor, first burned the gas simply as a flame from the end of a pipe. One day in an emergency he wished to stop the illumination. Hurriedly looking around for something, Murdock seized his wife's thimble and thrust it over the light, which was immediately extinguished. There was a strong odor of gas, however, and the experimenter applied a



Photo by Levick

The Woolworth tower is the king of New York's skyline at night. Its crown is a great scintillating jewel

light to the thimble, discovering that it was full of holes, through which tiny jets of flame appeared. The importance of the result was that the illumination from those two or three tiny jets was much brighter than had been given by the great flare from the end of the pipe. Acting on the principle which this chance discovery revealed, he constructed what was known as the Cockspar burner.

### Extinguishing an Oil Fire with Carbon-Dioxide Foam

FIFTEEN thousand gallons of gasoline were set on fire recently at the Greenpoint plant of the Standard Oil Company to test carbon-dioxide foam as an extinguishing compound. The oil was allowed to burn for about a minute during which time the flames and smoke gained such headway that a column of it mounted three hundred feet in the air. At this point the carbon-dioxide foam was turned on, and it was so effective that the fire was within control in a very few seconds and entirely out within forty-four seconds.

Most of the big oil tanks of the country are now protected by an automatic device which releases carbon-dioxide foam in quantities sufficient to put out the biggest fire. Where a tank explodes, however, other measures have to be taken.

Sand is most frequently used in these emergencies, and water, used in the early days of oil fire-fighting, is now never used, since it is heavier than oil and causes the gasoline to overflow and thus spread the fire instead of confining it.

Where vats of highly inflammable liquids such as benzine, naphtha and kerosene are stored, they are equipped with pipes so that they can be drained.

### Locating Guns by Delicate Earthquake-Detectors

SCIENCE has discovered that gunfire affects the earth's surface much like an earthquake, so it is not surprising to learn that guns are being located by the seismograph—the delicate little instrument which records terrestrial tremors. An Austrian authority on the subject of earthquake disturbances announces that the seismograph can record the position of hostile artillery as well as the caliber of the guns.

In the fairly recent engagement between Italian and Austrian troops at Isonzo, the tremors induced by the heavy cannonade were duly registered by the apparatus, and the operator was able to detect, by means of diagrams of artificial movements of the ground, the difference between the shocks produced by the fall of projectiles and those

caused by the recoil of the guns. Moreover, the form of the tracings revealed to the practiced eye the number as well as the caliber of the latter. From these results came the suggestion that movable seismographic stations ten to twelve miles in the rear of the trenches and connected with them by telephone would enable trained observers to transmit information to the commanding officer.



The oil was allowed to burn for a minute when the carbon-dioxide foam was forced into the blaze from the pipe which is shown at the left of the picture



Signal detachment, with flags and telephones, fording a river to lay a line of communications

### Throwing a Line of Communications Across a River

WHEN an army invades a country the most important thing after digging itself into the ground is to establish a line of communications. This duty devolves upon the signal corps. In the photograph reproduced above a detachment of our signal corps is shown advancing across a river with signal flags and a portable field-telephone equipment. By means of the flags they wig-wag their position to the forces in the rear which are protecting them. When the telephone line is completed it affords communication between the first-line troops and the ones behind, and between the commander and the heads of separate divisions.

### Blow-Pipes of the Borneo Land Dyaks

ALTHOUGH one of the simplest of weapons the blow-pipe used by the Land Dyaks of Sarawak, North Borneo, requires more skill in the making than any other instrument or implement of a primitive people.

No thin sapling sufficiently straight or strong for a blow-pipe is to be found in the forests of Borneo, so the laborious method of working down a large piece of wood has to be resorted to. The wood most favored is called *yong* by the natives. It is heavier than water and of very tough texture, but it is fairly easily worked, even after a couple of years' seasoning. The *yong* log is rigged up

vertically in a scaffolding, and almost on a level with the upper end of it is a platform upon which the driller stands. The task of the latter is to run a perfectly straight hole three-eighths of an inch in diameter through the whole length of the log.

As the hole deepens, longer handles are attached to the chisel blade, the last being as long as the log itself. The driller is invariably an old man, with years of experience behind him as a driller's apprentice. Considering his long training the accuracy of his work is remarkable. Only after the hole is completed, tested, and found true, is the less careful but still laborious work of shaping down the outside of the log taken up. This is done first with axes, then with the parang or native knife, and finally by scraping.

The dart of the Dyak blow-pipe is of some light wood—pith is sometimes used for short range work—and the tip is of bone, or steel. Where the latter is obtainable small birds can be brought down by the dart alone.



The Dyak blow-pipe requires infinite skill in working it down from a log



# SUBMARINE DESTROYERS

## A new use for motor boats



SKIPPERS sleep peacefully in their berths on the freighters lying in the Thames near London in spite of submarine warfare. Freight from America and other countries, munitions of war and food supplies, arrive there in such quantities that the boats cannot be unloaded immediately, but they are just as safe in the mouth of the Thames as they would be in New York harbor. For that, England has America and Russia to thank. Some enterprising Russian must have seen Flyaway III winning races in American waters; there is the secret of the safety of commerce in the mouth of the Thames.

What keeps the German submarine away is the huge fleet of pert, saucy, little American launches. All of them were developed from the lines of Flyaway III, one of the few new engines of war for which America is responsible. Each boat is sixty feet long and is driven thirty miles an hour by gasoline engines. "Submarine swatters," the boys down

on Long Island, New York, nicknamed them before they were shipped. With supplies of food and fuel for several days' cruise these boats spread fanlike from the mouth of the Thames, and from other shipping centers in England and Russia on the lookout for the wily submarine whose evil eye trails a tail of oil and bubbles behind it. In the deck house of the submarine swatter is a three-pound quick firer, capable of knocking the periscope clean off, or mortally wounding the submarine before it can come to the surface and get into action against the little American launches. No submarine can sail any waters where these fleets are located for half a day without being spotted, trailed, and destroyed. As was said before, the skippers of the freighters in the mouth of the Thames, waiting for a chance to unload, sleep peacefully on.

A trial order of these submarine swatters was given to a Greenport, L. I., construction company late last year, and



The motor-boat, up to this year considered insignificant in warfare, is proving to be the submarine's liveliest foe. Its powerful engine gives it speed and a wide radius of action





It looks like a peaceful, dumpy affair, but it can squirt death

shortly afterward six were shipped to Archangel, before that Russian port closed for the winter. Great secrecy was maintained as to the details, but after the second order was given, proving in the only way possible that the boats were successful, general specifications were admitted.

Each boat carries three 175-horsepower engines, giving a total of 525 horsepower to drive the load. The speed called for was twenty-six miles an hour, but the average, on the trials which could be held, was over thirty miles. The boats are sixty feet long, ten feet beam, and two feet ten inches draft. They weigh twenty-eight thousand pounds. There are accommodations for eight men, six bunks forward and two aft, the latter for the engineers. The pilot house, which is practically the only obstruction on the deck, is

armored and has room for a quick firer, which of course was not mounted before the boats were shipped to Russia.

The boats are of the V-type, a design which is but a year or two old in American motor-boats. The bow is sharp, but a few feet back is a shoulder on each side of the hull, which performs the same duty as the steps on a hydroplane, and lifts the hull partly

out of the water. The first large boat of this design which was completely successful was the famous champion racing cruiser Flyaway III, which is still champion. Were the new Russian submarine swatters to compete with Flyaway, a new winner would probably be announced. They are much larger, faster boats, in fact, the largest V-type ever constructed, and it is the success of this development which has so interested Americans.

As fighters, these motor-boats should be efficacious against submarines. They draw so little water that they can ride safely over the ordinary mine-fields without exploding the mines. They are equipped with two rudders so that they



Equipped with wireless it cuts through the water and rides safely over mine fields

can turn completely around in a little more than their own length, and hence can steer a violent zig-zag course. A submarine attempting to torpedo such a boat, traveling thirty miles an hour with so little hull to shoot at, would be attempting almost the impossible.

In realizing the tremendous advance of the motor-boat it must be remembered that these vessels can travel at high speeds, in almost any seaway, carrying eight men for long distances, and that they are armed in addition. A few years ago motor-boats did not travel so fast with one man, for a mile only, even on quiet, inland waters. And yet they are small enough to be placed on the deck of a warship. This is evidenced by the fact that each is equipped with cleats, bolted to the keel, by which it can be lifted from the water. This is the reason England has placed a very large order for duplicates of this American design.

#### Hitching the Mower to the Farm Automobile

A CALIFORNIA ranchman (James M. Berry, Sacramento) found that pea vines came up so thickly in a grain field that it was impossible to cut the grain. He decided therefore to cut it for hay. Because of the shortage of horses he tried hitching the mower behind the ranch automobile. The plan worked so successfully that about twenty acres were cut each day, the car drawing the mower at such speed that the mower readily cleared itself. When horses were



The farm automobile took the place of horses and did the big job better and in less time

used, the blade frequently clogged itself.

The hay was raked by the same method. In the fall the automobile was used to run a stacker. The lift rope of the stacker was attached to the front axle of the car and when the operator desired to raise the load of hay he would back the automobile until the stacker had cleared itself. Then it would be lowered by reversing the machine, letting it down gently, whereas horses would jerk the stacker and let it down abruptly, with a bump.

#### The Reinforced Concrete Principle Applied to Automobile Tires

A NEW tire has been patented which combines elasticity with great durability. The principle is similar to that employed in reinforced concrete; a

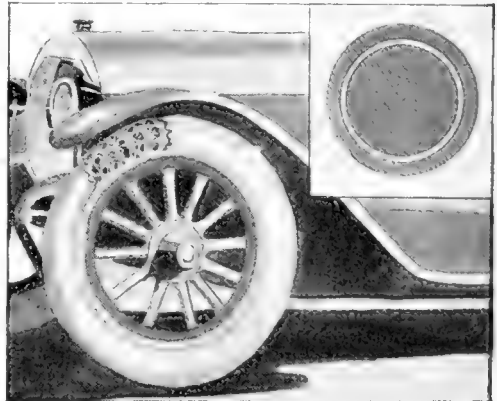

A portion of the tire with the "shoe" cut away, showing the reed woven into a network of strands

woven fabric is embedded in a body of elastic composition.

Vegetable reed, preferably "Spanish cane," is woven into a network of circular and longitudinal strands. There may be one or several tube-like arrangements, or a spiral effect may be used. The spans between the fibers are filled with a substance which can be poured in when hot and allowed to solidify. This composition is highly elastic and yet is strong enough to resist road bruises.

Its main advantage over the solid rubber tire is its elasticity and durability. No road is too rough for it and it will bear up under the hardest service. The "Spanish cane" adds greatly to its wearing qualities in all sorts of weather.

**Boy's Road Wagon  
is a Real Locomotive**

**A** MECHANIC in a garage machine-shop in Eugene, Oregon, wanted his boy to know something about the mechanics of a locomotive, and in his spare moments constructed the machine in the accompanying illustration. It is a perfect miniature of a large steam engine, and is complete in every detail. It carries a pressure of steam up to forty-five pounds, and pulls the tractor with two passengers at a speed equal to a fast walking gait.

The engineer and owner is a boy nine years old, and he has already obtained a remarkable knowledge of the actual working of a steam locomotive from the operation of his little machine. The engine burns coal, pitch-knots, and small pieces of bark and wood.

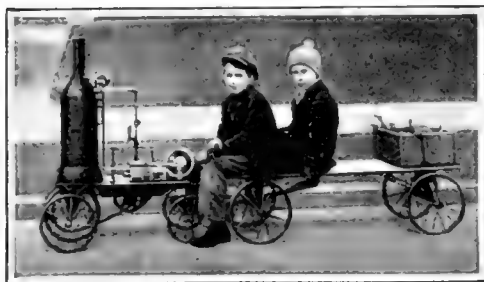

The locomotive with the engineer in overalls and his trusty fireman behind him

**Wind Cave Excels  
Mammoth  
Cave**

**W**IND CAVE, National Park, in the Black Hills, about twelve miles from Hot Springs, is on the Deadwood-Denver scenic highway—the "Triangle D" road of the West.

Wind Cave enthusiasts claim that this cavern excels the Mammoth Cave of Kentucky in splendors and in extent. Half a dozen government surveys have been made in the park. These and various private exploring expeditions that have been organized have accounted for some 96 miles of the recesses of Wind Cave, but there are hundreds of passageways that have never been explored. No one knows to what depths they lead, or how far under the Black Hills they may take the explorer.

The average visitor to Wind Cave, National Park, travels from six to ten miles underground and comes forth into the daylight realizing that he had seen but a small fraction of this great cavern.

Wind Cave takes its name from the strong current of air which almost constantly surges in or out of the entrance. It is said that this led to the discovery of the cave in 1881.

Many explanations as to this mysterious rush of air at the entrance to Wind Cave have been advanced. Some have claimed that the rise and fall of mysterious lakes, many hundreds of feet underground, where no exploring party has yet penetrated, are the cause of these air currents. A more generally accepted theory, however, is that the air pressure outside is the cause of it all. The cave is a huge barometer, responding to every change.

**A Cane to Help the Convalescent Soldier**

**A** CANE intended to make walking easier for the convalescent soldier has found popularity in England where every ship from the war zone brings wounded men still too weak to walk great distances but sufficiently recovered to be about. It is of stout construction. It has a curved handle and is fitted with a rubber tip so that it is a safe support when traversing slippery pavements. The unique feature of its construction is a folding foot-support which opens on the principle of a knife-blade, a few inches from the bottom. This the soldier uses as a rest.

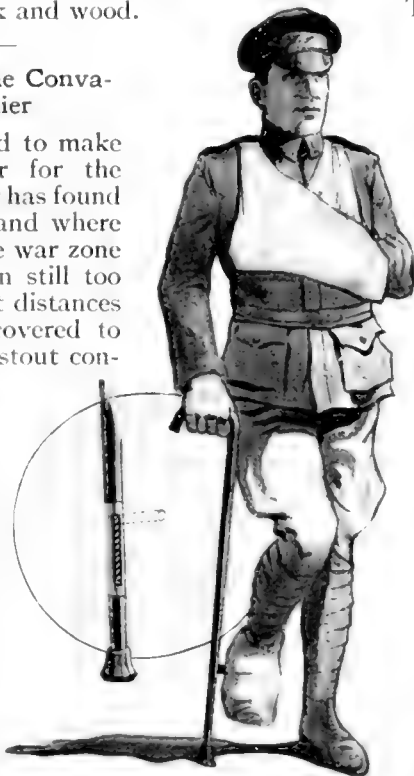

How the cane foot-support assists the soldier in walking

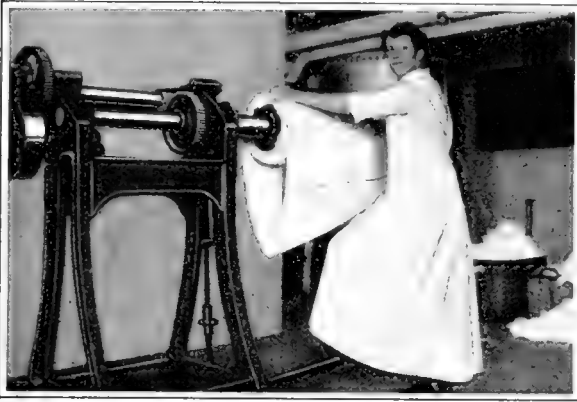

The skirt is guided by the two hands and the machine operated by treadle, to obviate all danger

### At Last! a Machine Which Irons Skirts Without a Murmur

AMONG the latest of labor saving devices is a skirt ironing-machine invented by a Troy, New York, man. The skirt to be ironed is placed over a big conical roller. The ironing member is a hollow structure that fits over the conical roller and is supplied with steam to do the ironing. The conical roller over which the skirt is placed is operatively connected with a treadle, which when depressed raises the roller so that the ironer presses the garment.

### An Air-Tight Compartment for Canoe Campers

FOR the convenience and safety of canoeists an improved form of air and water-tight compartment or locker has been invented. It not only affords a storage place for food and sufficient equipment for a small camping trip, but also provides a buoyant means for the canoe should it upset.

The metallic locker fits snugly into the forward end of the canoe. All seams are made water and air-tight, and a circular opening, fitted with a water-tight cap, is provided through which food, clothing, ammunition or other supplies may be placed without fear of them getting wet. The locker is bolted to the canoe frame, and a padlock and chain prevents the cap from being removed.

### Soldier of Today Better Off Amid New Horrors

THOSE who argue that the horrors of applied science exceed its blessings are ignorant of the soldier's life. The soldier in to-day's war is infinitely better off amid all his new horrors than was the soldier of yesterday. The man in the trench is "the darling of time." Death stares him in the face, but a thousand hands are stretched forth by science to snatch him from those jaws.

In the words of Sir William Osler: "What shall be our final judgment—for or against science?

War is more terrible, more devastating, more brutal, and the organization of the forces of Nature has enabled man to wage it on a titanic scale. More men will be engaged and more will be killed and wounded in a couple of years than in all the wars of the previous century.

"To humanity in the gross she seems a monster; but on the other side is a great credit balance—the enormous number spared the misery of sickness, the unspeakable tortures saved by anesthesia, the more prompt care of the wounded, the better surgical technique, the lessened time in convalescence, the whole organization of nursing:

"The wounded soldier would throw his sword into the scale for science—and he is right."

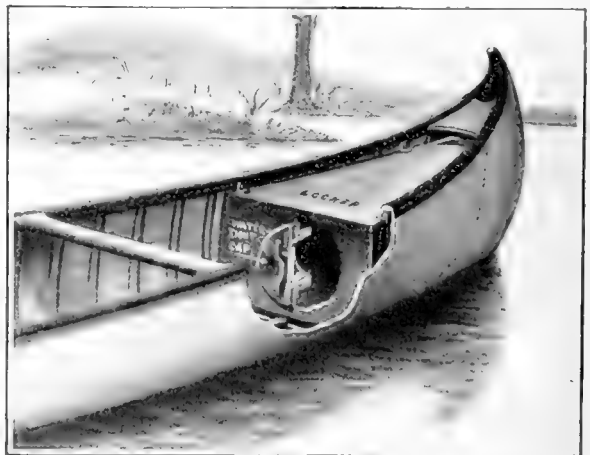

The air-tight locker is a storage place for a camping equipment and also prevents the canoe from sinking

### Accelerating the Fruit-Picker with a Picking Harness

THE fruit-picker who has long put up with the inconveniences connected with picking fruit from trees will welcome the appearance of a picking harness. The harness consists of broad straps or suspenders to which the fruit basket or pail is hung in front, leaving the hands free for picking.

Equipped with it the picker goes about his task with ease, placing the fruit in the receptacle in front of him. He does not need to worry about its getting away from him, as the old pail hanging on the tree-branch often did, and he can strip a tree clean of its fruit in much less time with the new harness. In the berry season the harness can be used to advantage, and it is a great improvement for all workers in the orchard.

### A Deep-Sea Fish Which Has a Lantern of Its Own

AMONG the most remarkable fishes are those provided with lanterns of their own, and which swim in the dark recesses of the bottom of the deep ocean where no ray of natural light from above can penetrate. A model of one of these fishes, notable for its phosphorescent organs, is on exhibition in the United States National Museum. The sides of the fish are dotted at regular intervals with luminous spots, which may be seen in the illustration. In addition there is a

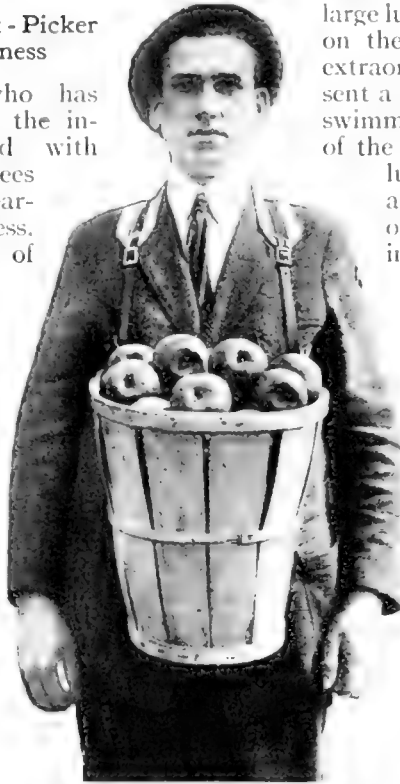

This harness is light and enables the fruit-picker to work with both arms

large luminous area like a lantern on the top of the head. This extraordinary creature must present a singular appearance when swimming in the dark abysses of the ocean. In the model the luminous spots on the sides are represented by buttons of glass connected with the interior by tubes. The

luminous protuberance on the head was modeled in gelatine and then tinted. When in operation the model is connected with electric current so that a distinct glow appearing in the side spots and the frontal "lantern" produces a very striking and, it is believed by fish experts, a quite accurate representation of the appearance of a living phosphorescent deep-sea fish. The model is about a foot long.

### A Sailor's Nautical Wind-Wheel

A NOVEL wind-wheel which gives the effect, even in a light breeze, of two sailboats pursuing each other in a circle can be constructed easily and will prove a source of considerable amusement to children. Through the center of a strip of wood a yard in length, no wider than one inch and no thicker than one-half inch, a nail is driven which serves as a pivot. At either end of the stick a miniature sailboat is mounted.

The boats should measure about twelve inches in length, with a tapering bow and stern which may be whittled or sawed. A mast is mounted in the bow of each, and a triangular cloth-sail tacked or sewed in place. For a ship-shape wind-wheel, the sail may be stiffened with a sturdy boom.

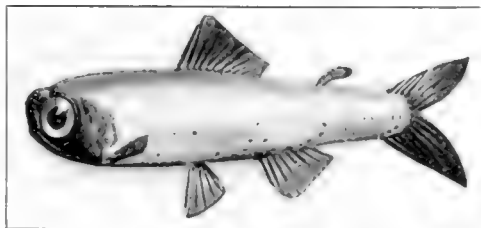

The luminous spots are represented by buttons of glass which light periodically

# What the Great Army of Inventors

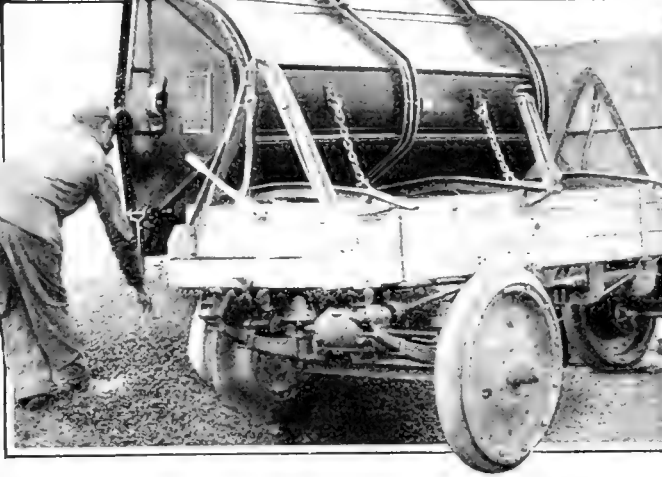

One man can easily tilt this truck body and discharge a load of two tons in thirty seconds



An electric flash-lamp with a bulb in the form of a hand, is one of the latest automobile signals for warning a driver behind at night



A motor-ambulance used by Australian troops in Egypt. The curtains form a temporary shelter. They are attached to stakes in the ground and pulled taut

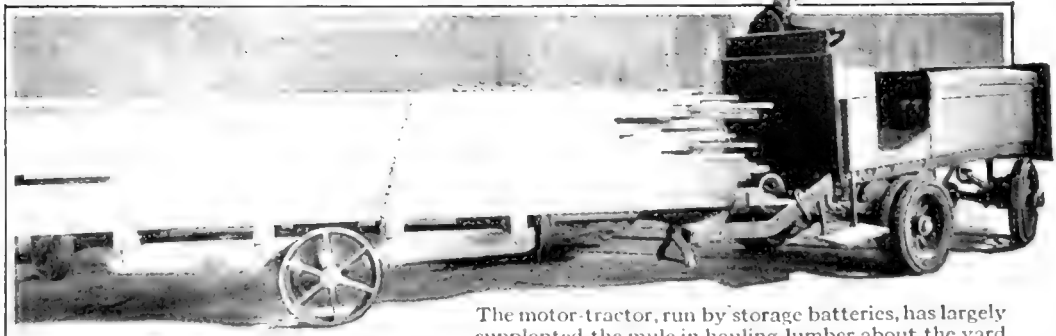
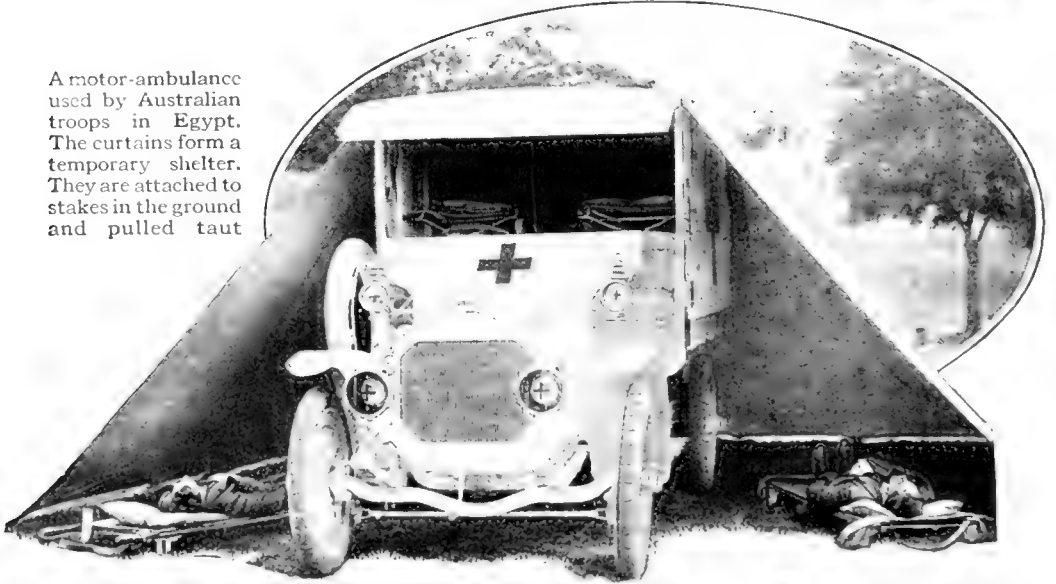

The motor-tractor, run by storage batteries, has largely supplanted the mule in hauling lumber about the yard

# Are Doing to Make this a Horseless Age

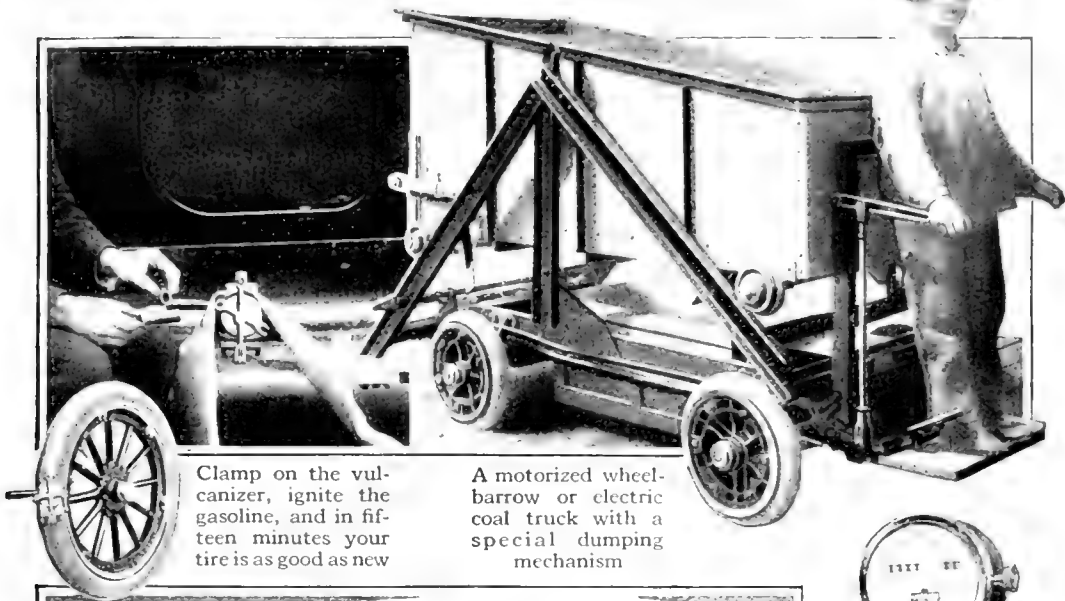

Clamp on the vulcanizer, ignite the gasoline, and in fifteen minutes your tire is as good as new

A motorized wheelbarrow or electric coal truck with a special dumping mechanism

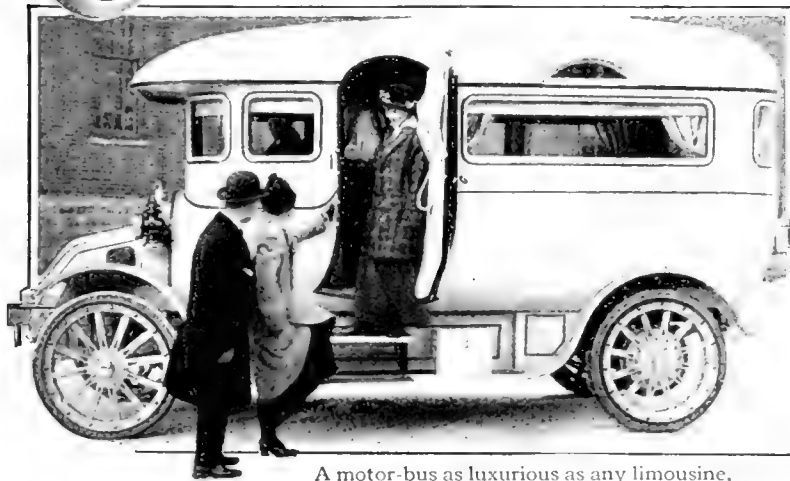

A motor-bus as luxurious as any limousine, used by a hotel in Winnipeg, Canada, to carry passengers to and from the station

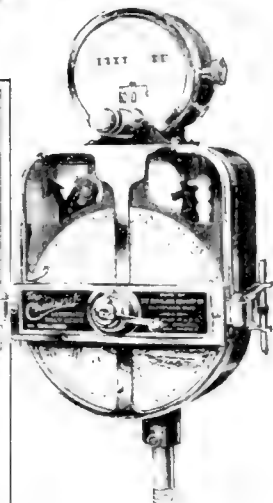

This machine warns the motorist of road dangers ahead

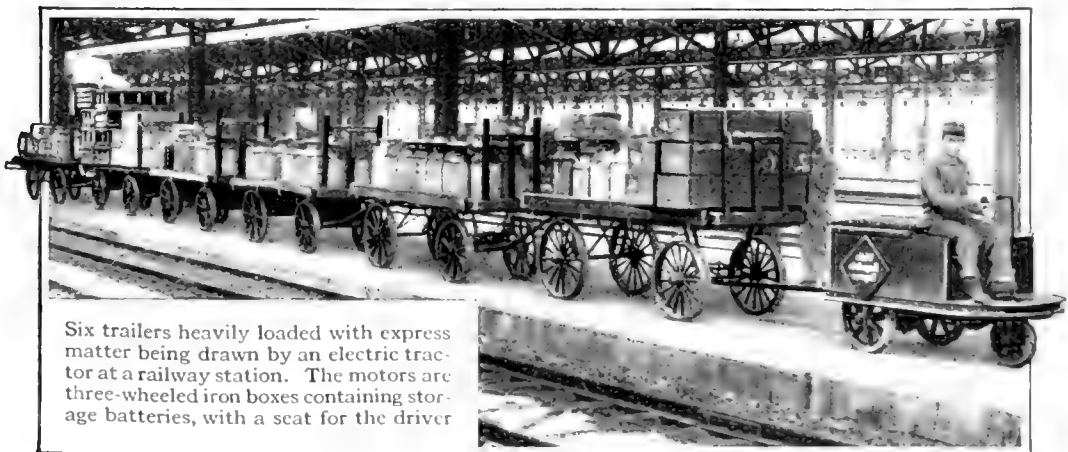

Six trailers heavily loaded with express matter being drawn by an electric tractor at a railway station. The motors are three-wheeled iron boxes containing storage batteries, with a seat for the driver



# What's New in

# Automobiles

Motor-truck climbing a lumber pile at a grade of forty-nine degrees

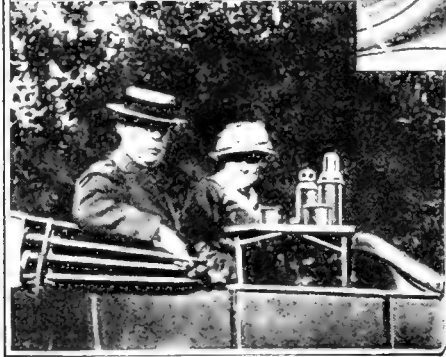
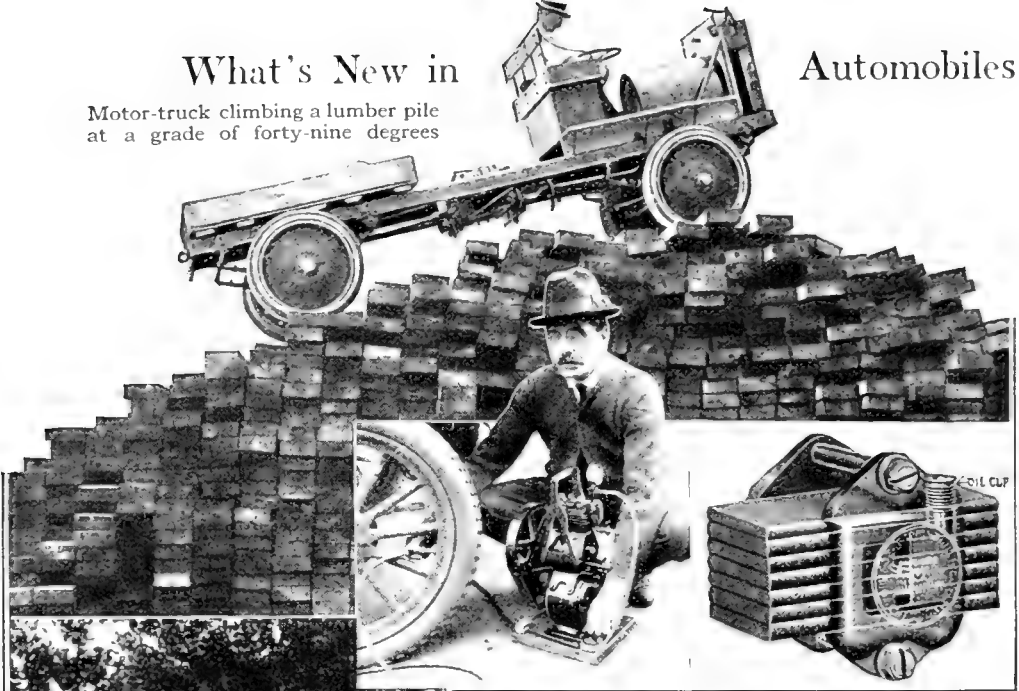

At left above, an electric tire-pump of one fourth horsepower. At right, a leaf-spring oiler which diffuses oil through the motion of the car

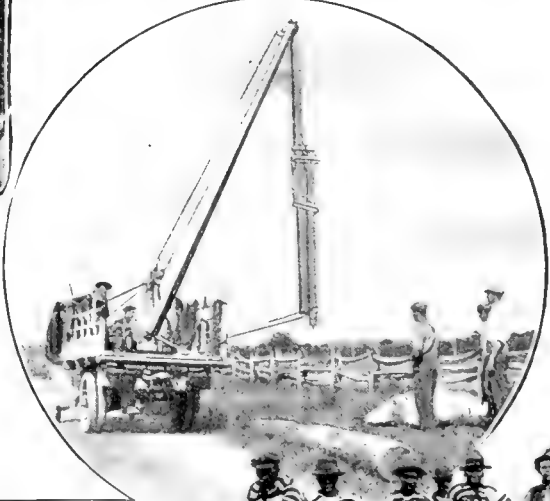

The appetite aroused by motoring can be appeased on a convenient little folding table attached to the door of the automobile

At right, an efficient telephone and fence-pole setting apparatus

In Tampa, Florida, this convict-manned auto-truck is used for street sprinkling in the summer and rubbish gathering in the winter





and in Their Accessories

At left, the hinged tailgate and inclined platform enable this truck to load automobiles from the ground and from box-cars in a minimum of time

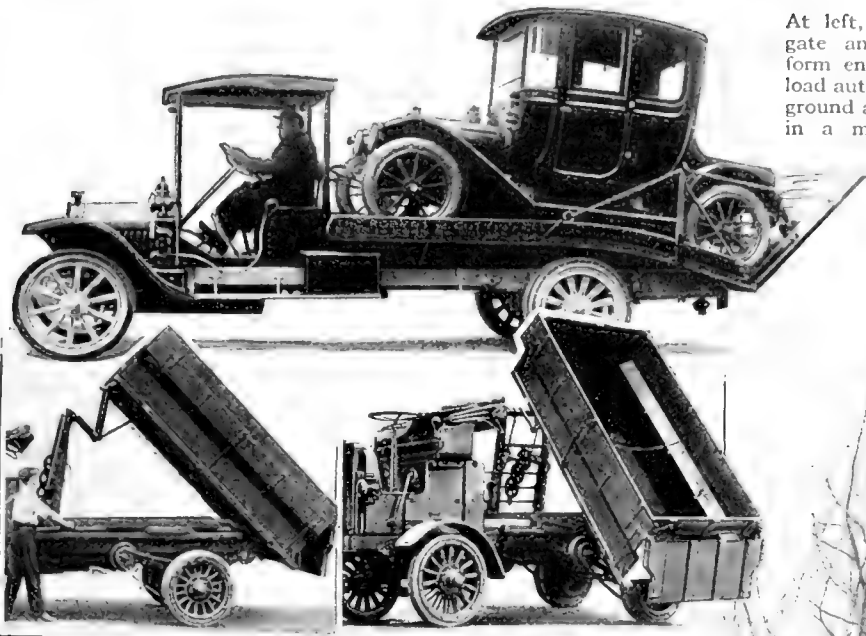

The load of the motor-truck shown above can be dumped to either side in the narrowest streets by operating the turntable



Behold a sidecar delivery buckboard. Mounted on the chassis are two boards about eight inches wide and six to eight feet long. They are strapped together with iron and are equipped with hooks on the four buckboard corners

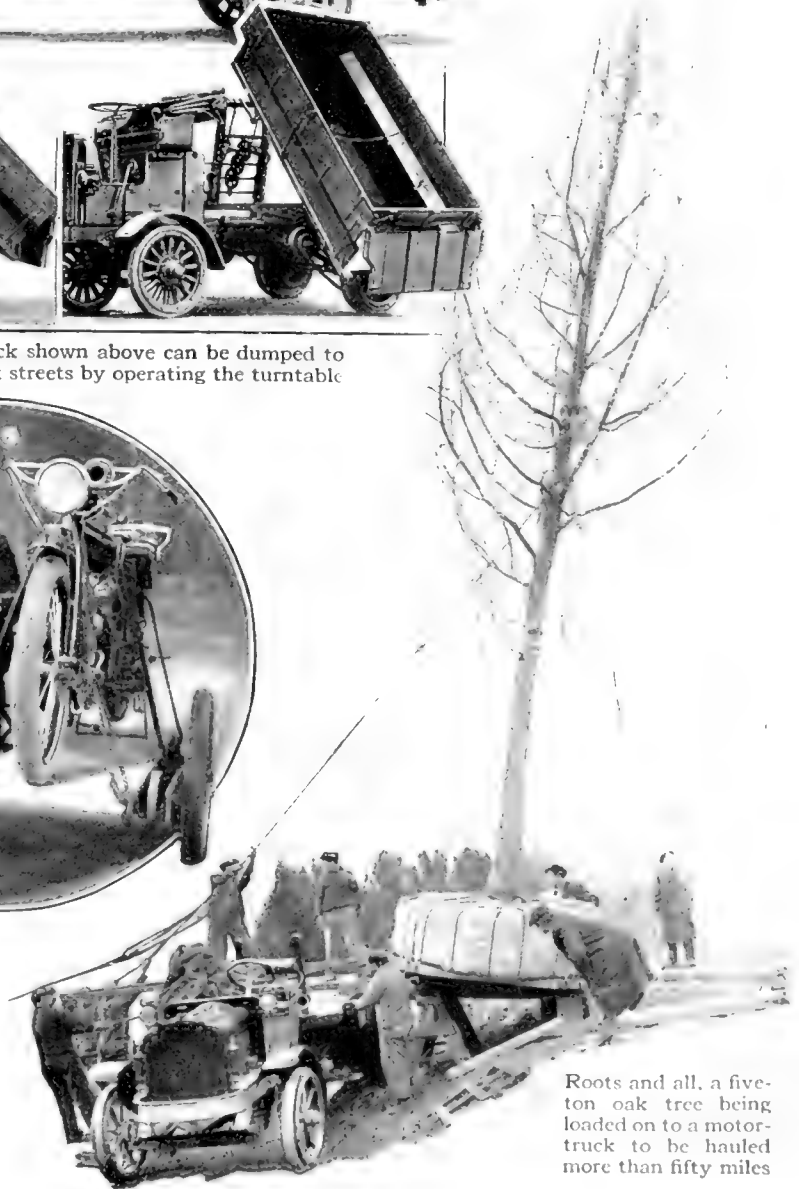

Roots and all, a five-ton oak tree being loaded on to a motor-truck to be hauled more than fifty miles

# If We Had Eyes Like Microscopes

By Edward F. Bigelow

CERTAIN writers, chiefly Dean Swift and his followers, have taken pains to impress upon their readers the fact that if they had microscopical eyes, all beauty would disappear. The most delicate skin viewed by such eyes would be rough and repulsive; the whole world would be filled with disagreeable sights.

On the other hand many enthusiastic microscopists teach and believe that beauty is increased by the microscope. According to them, if we had microscopical eyes, a world of beauty unimagined would be open to us, and every object would appear to be perfect and beautiful.

The disputed facts are like those in many other cases: each is right from his own point of view. The microscope does detract from the beauty of some things, and reveals new beauty in others. The appearance of nature to a microscopical eye would not be much different from its appearance to what we now consider the normal eye. At present, some things are unpleasant to look at; yet we are living in a world of beauty—everywhere.

In some things nature will not bear close scrutiny. In others, she has hidden beauty that is revealed only by the microscope. Among the most beautiful of finely constructed objects, few are perhaps more attractive than a mosquito's wing. Its tiny scales become more and more beautiful and wonderful as we increase our magnifying power.

The utilitarian reader may ask, "Of what use are such things?" They are good to be themselves. It is better to take the world as it is and to study it, than so often to ask, "Why?" It would

be difficult to explain the reason for the existence of many of nature's common objects. In regard to the mosquito's wing with its feathers, we can only surmise that these scales may be useful in preventing the air from slipping off too easily; the slight roughness may give the wing a firmer hold on the air. For

a similar purpose a bird's wing is feathered, and this reason is brought into more conspicuous prominence by the fact that a fish's fin is free from scales.

Here, aside from its reason for existing, the microscopist finds a realm for delightful investigation; the further afield he goes with his high-power objective, the greater the scope of inquiry. It is impossible in a photomicrograph such as the accompanying, although it is a remarkably good picture, to show the minute details, because the structure is so hyaline or

transparent, that it is not easily photographed. Under high powers the wing becomes even more hyaline.

If the reader will think of a room full of smoke, he will understand this. If a small quantity of this smoke-laden atmosphere be taken in a phial, the blueness will become invisible, or at least inconspicuous. When viewing a mosquito's wing it is difficult, under high magnification, to have enough material to make much impression upon the plate; but in a compound microscope the light may be so adjusted that, while the wing may appear almost perfectly transparent, there will yet be sufficient material to make a distinct image in the eye. There seems to be nothing too minute for the microscope to reveal.



The delicate mosquito's wing revealed through microscopical eyes

# Comic Insect Photography

By Lehman Wendell

ONE of the most interesting of all photographic diversions is the making of comic insect pictures. Success in this class of work requires a suitable camera, good taste and judgment in composition, and an unlimited amount of patience and perseverance. The importance of the second and third qualifications is too self-evident to need further attention, but a word or two regarding the equipment may not be out of place.

Any plate camera having a long bellows extension and an anastigmat lens will serve the purpose. A so-called miniature camera is preferable to a large one, because by reason of the short focus of the lens it has a greater depth of field and all parts of the picture can be brought into sharp focus at the same time, giving a wealth of microscopic detail throughout the picture. Needless to say, pictures of this class are interesting in proportion to the amount of detail shown.

Plates are preferable to films. They are coated with a finer emulsion, so that enlargements can be made to any reasonable size without presenting a mottled appearance or a loss of detail. Furthermore, plates can be had in such a variety of emulsions and speeds that by proper exposure and development the desired quality

of negative can always be obtained.

The pictures accompanying this article were staged and photographed indoors. It would be out of the question to take such pictures out in the open, where the slightest movement of the air would be sufficient to upset the whole scheme of arrangement. The insects themselves were first captured, then anesthetized and posed. The great variety of poses needed for pictures of this kind would, of course, preclude the use of dry museum specimens.

Chloroform is perhaps the best anesthetic for this purpose. The simplest method of administration is as follows: Moisten a pellet of cotton with the chloroform and place it in the bottom of a small wine glass. Next drop the insect into the glass and cover with a

small sheet of glass. This will prevent the chloroform from escaping. Complete anesthetization will follow in from two to five minutes. The staging of the picture should be done immediately, and the exposure made before the insect has had time to recover from the effects of the chloroform.

Naturally, one of the main difficulties is to get the insects to stand upright, but a little ingenuity on the part of the photographer will soon solve each individual



Above, "At the Photographer's." At left, "The Elongated Cigarette Smoker." Below, "An Old Salt." This last was staged in a saucer. The canoe is a pea-pod

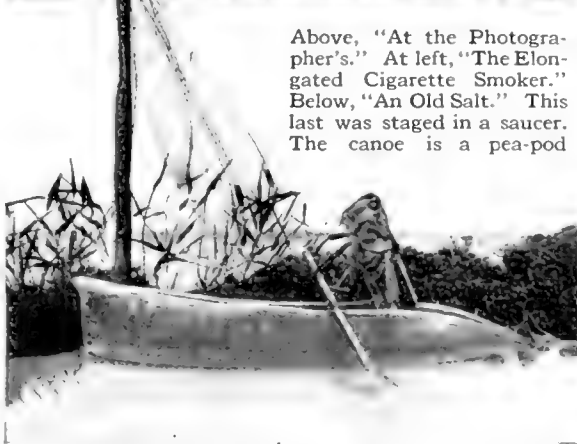

problem. In many cases all that is necessary is to balance the insect carefully against some object, as was done with the cigarette smoker. In other cases a prop of some sort will be required, and this may be thrust into the body and then into the moss. A fine wire is excellent for this purpose. Of course the wire must be carefully hidden.

In most of my pictures the foreground consists of some species of moss. This can be found growing in abundance in rocky localities or in low swampy woods. A great many varieties exist, so that sameness in one's pictures may be avoided. Where bushes are needed to break the monotony of the landscape some kind of lichen may be employed. The kind which I use is found in rocky localities growing in dense masses many feet in circumference. By carefully separating a small portion from the mass, an excellent imitation of underbrush will be obtained.

My backgrounds are, as a rule, white, as this seems to set off the insects to best advantage. A light blue sheet of paper is employed for the purpose, blue photographing white. White paper should not be used as it is apt to reflect too much white light into the camera and produce a fogging of the plate.

Occasionally clouds will be found to add interest to a picture, and these may be printed in from a separate cloud negative made for the purpose. It is well to have a dozen or more such negatives on hand, so that a repetition of the same cloud effect may be avoided.

Now let us consider the production of the pictures one by one. I can perhaps serve the reader best by quoting some of the data recorded in my note book.

"An Old Salt."—Staged in a saucer of water. Background, moss. Canoe, peapod. Paddle carved out of wood. Clouds printed in. Plate, Hammer's Exfast Ortho. Time of exposure, 30 seconds, F:36, near west window, sun bright, 2:30 P. M., August. Pyro tank developer. Cyko enlargement.

"At the Photographer's."—Camera, small cube of wood, dipped in ink. Lens, small section of hay cut at one of the joints. Tripod, three fine wires thrust into the camera, and fine stalks of hay slipped over wires. Other data as before.

### A Tool for Buffing, Drilling and Grinding Metal Surfaces

**S**ANDPAPERING and polishing unwieldy or immovable objects is a task, which, done by hand, requires a vast expenditure of time and muscular effort. Portable electric grinders and buffers have been perfected to do the same work in a fraction of the time and with results that exceed the finest of hand work.

A light, compact electric motor on a no-tipping pedestal is provided with a handle by which it is easily carried and with a long cable that is attached to the nearest electric light socket. A snap switch on the side of the motor controls the current supply. Power to turn the buffer or grinder is supplied through a long, flexible tube.

The instrument has found its way into a variety of interesting uses. Some adaptations of it are employed in automobile garages for polishing brass and enameled surfaces. Crevices which could only be reached with difficulty are cleaned out in an instant by the whirring disk. This tool finds itself welcome in workshops where odd and difficult jobs such as die-sinking, drilling, buffing, grinding and those of similar nature are daily encountered. Another form of the tool helps in lightening the task of the floor-layer. In this case, the motor is attached to the ceiling and the flexible tube operated from the end of a long pivoted arm. Among the other unique applications of the buffer and grinder are those of cleansing household utensils, signs on the front of buildings and performing other tasks of an equally diversified nature.

### Pneumatic Gun with a Dynamite Shell

**A** BALTIMORE man has laid before the navy officials the plans for a pneumatic gun with a dynamite shell. It is said that a test of the gun is shortly to be made. The inventor began working on his invention some months before the war started, and only completed it last summer. The latest model is a 20-pounder, which he has made adjustable to hurl a dynamite bomb as far as 22 miles.

# What a Little Electric Motor Can Do

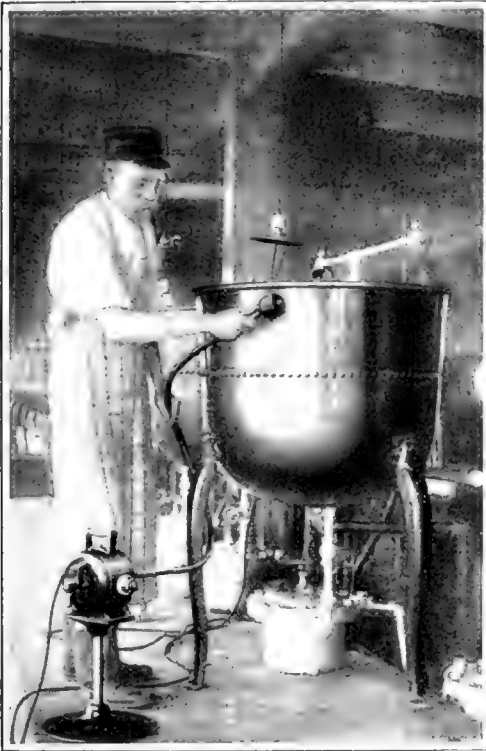

Buffing a copper caldron

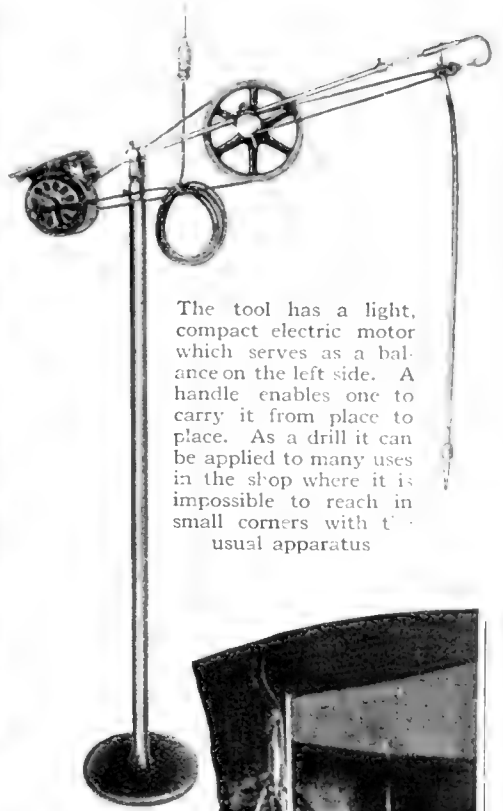

The tool has a light, compact electric motor which serves as a balance on the left side. A handle enables one to carry it from place to place. As a drill it can be applied to many uses in the shop where it is impossible to reach in small corners with the usual apparatus

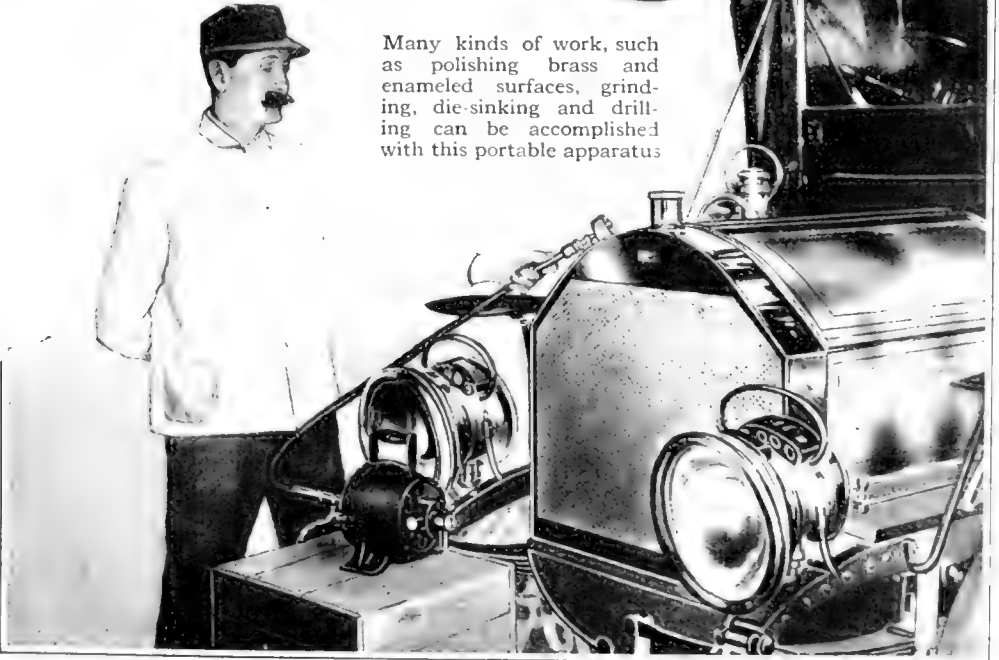

Many kinds of work, such as polishing brass and enameled surfaces, grinding, die-sinking and drilling can be accomplished with this portable apparatus

It is an advantage to bring the tool to its work. All that is needed is an ordinary electric light socket. As a polisher for the various automobile brass parts the tool is especially useful

# Trapping English Sparrows for Food

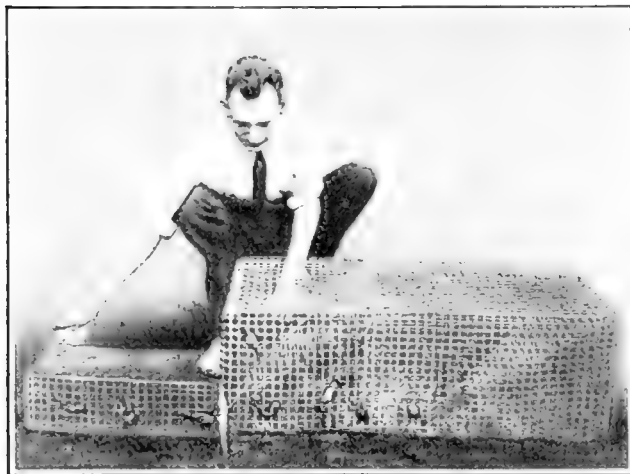

The mouths of the funnel are just large enough to admit the sparrow and keep him prisoner

**H**EREWITH is shown a trap for catching the Englishsparrow which is one hundred per cent efficient, if properly operated. It is made of tinned wire, electrically welded, strong and durable. The size of the trap is thirty-six by eighteen by twelve inches, and weighs twenty-five pounds.

The United States Department of Agriculture advocates the destruction of the English sparrows, calling them "noisy, quarrelsome, filthy and destructive." Native song-birds will never come back to our gardens in increasing numbers until the English sparrow is banished. These pugnacious birds are extremely cunning, and it is hard to trap them. But there is no trouble in enticing them into the trap shown if the proper kind of bait is used for a particular locality.

The flexible needle-points at the mouths of the funnels can be adjusted so as to be just large enough to admit the sparrow and yet not large enough for him to return. One family who used cracked corn for bait caught seven hundred and twenty-nine sparrows in sixty days. The usual method is to sprinkle

bread crumbs for six feet around the trap, leading the crumbs into the funnel. Large pieces of stale bread are used near and in the trap. Sparrows, being like hogs, in that they like to get where the big feed is, soon go from the first into the second division, from which they are easily forced into the last part, from which they are taken.

There is no reason why sparrows should not be utilized for food, as they have been in the Old World for

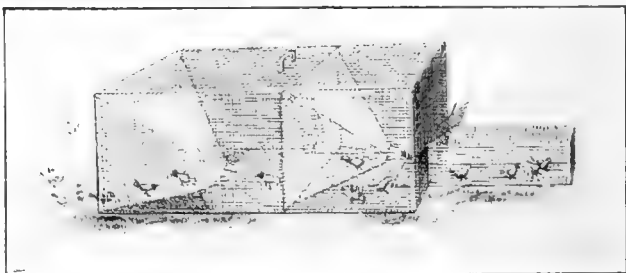

The bird-trap can be used at any place where sparrows congregate, even on the roofs of city apartment houses

centuries. Their flesh is palatable, and though their bodies are small, their number fully compensates for their lack of size. Birds that have been trapped have been kept in large out-door cages, sheltered from storms and cold winds, until they are wanted for the table. It is unprofitable to keep them long, as the quantity of grain or other food they require daily amounts to more than half their own weight. A variety of food is necessary to keep them in good condition. Bread, oats, wheat, bran and corn-meal mush, lettuce, cabbage and tender shoots of sprouting grain are some of the things they relish. Some time ago ex-Governor Cox of Ohio gave a banquet to some of his friends, when the piece de resistance for the occasion was a sparrow-pie. Until after the banquet the guests were under the impression they were eating a pie made of squabs or reed-birds.

### A New Garden Duster Which Uses Dry Spray

THE use of dry sprays instead of liquid poisons is coming into favor among garden makers because they involve less work, are not so dirty and are ready for instant use. A new hand duster for applying dry sprays is novel in principle as well as design and is by far the most efficient device which has yet been invented. The powder is contained in a large metal reservoir, within which the pump mechanism acts. Each movement of the piston automatically measures and ejects an amount of dust regulated by the force imparted to the piston. It is double acting and will throw a cloud of dust or powder up or down or in any other direction. With this new duster a single puff of arsenate of lead will completely cover a potato plant with the poison. All vegetables and small fruits and even low trees may be quickly sprayed with poison or with sulphur with a minimum of effort.

The duster may also be used as a house disinfectant, discarding the arsenate of lead for a non-poisonous liquid or powder. No corner is beyond reach of the duster, and the acids used as sprays do not injure it.



The liquid is forced into the recesses of vegetables, small fruits and low trees

### How the Snail's Tongue Cleans the Aquarium

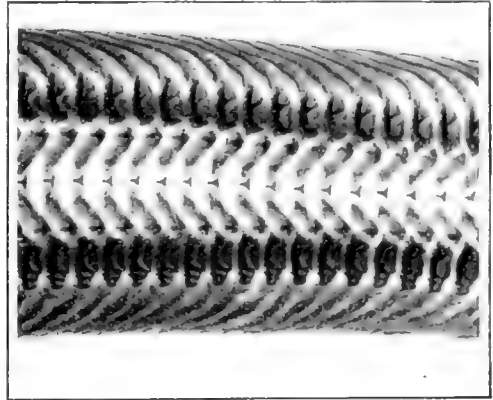

The snail has a tongue which closely resembles the teeth on a carpenter's rasp

EVERY one who keeps an aquarium knows that it is advisable to place a few snails in the tank, not only because snails are interesting in themselves, but because they are good cleaners. If the keeper of the aquarium knows that too much sunlight will produce too much plant growth, and has placed the vessel in a partly shaded place where the proportion of light and shade is about right, the snails, if they are numerous enough, can then control the growth. They creep along the side of the aquarium, as if they were idling away their time and merely crawling around to call on their neighbors. In reality they are not dreamers but scavengers.

Nature has provided them with a peculiar anatomical structure resembling a narrow ribbon, which in detail is like the band of teeth on a carpenter's rasp. Under the microscope these so-called "lingual ribbons" or tongues are seen to be thickly set with rows of sharp-edged teeth which are themselves toothed and which rasp off microscopic plants and carry them into the mouth.

The accompanying illustration is from a marine form known as the "bleeding-teeth" snail. In the original the ribbon has a bright reddish color as if it had been dipped in blood. When the image is thrown on the screen by the projection microscope, it resembles a huge red rasp three or four feet in diameter and extending across the entire width of the screen.



# Machines That Smoke Cigars

## The Modern Way of Sampling Tobacco Leaf

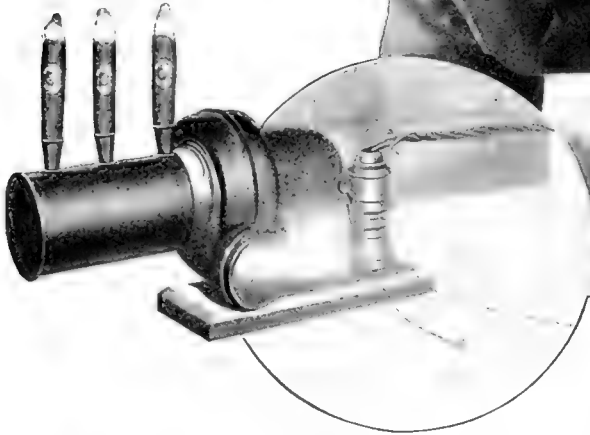

Above, the aspirator and siphon apparatus for testing tobacco leaf. It smokes four cigars in thirty minutes. At left, the blower outfit which is operated by electricity. The smoke is coming from the exhaust outlet

**T**HERE are tea-tasters, perfume-smellers and silk-feelers, but when it comes to smoking cigars to determine their uniform burning, their ash color, and the aroma of the smoke the human element is entirely dispensed with and machines—cigar-smoking machines that can smoke four cigars at once and never smoke themselves to death—are used. These are of two kinds. The cigar buyers use a simple blower outfit, and the Bureau of Plant Industry of the Department of Agriculture tests its tobacco leaf with an aspirator and siphon apparatus.

When the buyers come to New York for their season's supply of tobacco they take the blower machine with them, and after selecting certain qualities of tobacco have cigars made up on the spot, connect the blower to an ordinary lamp socket, insert the cigars and watch results. The way the cigar burns, the color of its ash and the aroma of the smoke are indications as to the quality and desirability of that certain brand.

The Bureau of Plant Industry has an interest in tobacco entirely different from the cigar buyer. It is endeavoring to improve tobacco by a scientific study of the different brands. To eliminate the personal equation in smoking and to

secure uniformity of conditions the Bureau has a unique apparatus for testing the burning quality of cigars. The "pull" on the cigar is secured by means of an aspirator which is filled by a continuous inflow of water and emptied at regular intervals by a siphon. The "pull" occurs at intervals of thirty seconds and continues for a period of ten seconds. The apparatus smokes four cigars of the perfecto type in about thirty minutes.

There are several elements which go to make up a good or bad burn, chief of which are the capacity for holding fire, the evenness of the burn, the color of the ash and its firmness, the coaling or carbonization, and the "puckering" of the leaf immediately in advance of the burning zone of the cigar. The final test of any cigar tobacco must, of course, rest in the smoking of the manufactured cigar, but, while this gives a direct means of determining the character of the ash, it does not furnish accurate information as to the evenness of the burn or the fire-holding capacity of any one of the components used in the experiment. Tests have been made using different fillers and binders with the same wrappers.



### Rocks Composed of Diatom Earth Which Float

A NUMBER of rocks are so light that they float on water. Most of them consist of diatom earth, which is a soft earthy material like chalk, but differs from it in being composed chiefly of silica-containing plants mixed with the remains of submerged organic growths, or diatoms. Diatoms flourish in the surface water of parts of the ocean, especially in the South Atlantic, where they are so abundant as to becloud it and where they serve as food for whales. Their remains sink to the bottom and form great accumulations of diatom ooze.

Diatom earth is found in many parts of the world, and is extensively used for polishing. It has been used also as an absorbent in the manufacture of explosives, and as a packing about steam boilers. The "silver white" of commerce is diatom earth. In the United States it occurs at many localities, of which two



The Colorado River after one of its overflows when the water has receded and the western sunlight has baked the bed

### A Mud Mosaic in the Wake of the Treacherous Colorado

WHEN the great Colorado River goes on a rampage and overflows its banks it deposits vast quantities of mud and sediment. In this way it has built up the enormous rich Colorado delta in Arizona and Southern California, cutting out, through the countless ages, the huge gorge of the Grand Canyon, in many places a mile deep through the rock. The photograph shows what happens to the Colorado River clay, upon the recession of the waters. Drying under the intensely hot sun, which normally reaches one hundred and fifteen to one hundred and twenty degrees in the shade, and cracking into innumerable irregular blocks, it forms a vast natural mosaic. In some places where the water has stood over a flat, this mosaic extends as far as the eye can distinguish.

The Colorado delta is intensely arid in character, only a few clumps of salt bushes being able to subsist. Where it has been irrigated the yields are enormous. The fertility of the soil is almost inexhaustible. The complete harnessing of the Colorado and the utilization of its tremendous flood-flow constitute one of the really big reclamation engineering problems of the day.

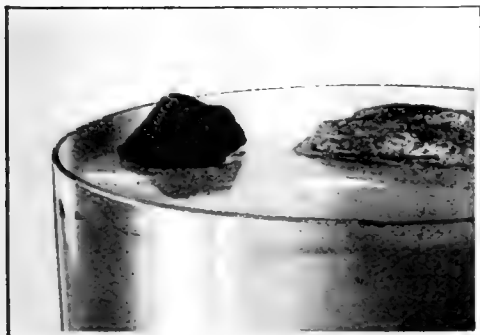

On the left is a piece of rhyolitic pumice and on the right a piece of hydrocarbon

may be mentioned. Near Richmond, Virginia, it forms a bed thirty feet thick and one hundred miles in extent; and near Monterey, California, there is a bed of it fifty feet in thickness, but of unknown extent.

When samples of it are subjected to a water bath for hours they seem not to absorb the water. To attempt to "water-log" a piece of pumice is foolhardy.

# Fighting the Sand-Peril

At left, the sand encroaching upon valuable fruit-growing land, stifling it to death. It travels with an utter disregard of all barriers thrown against it by man

Below, boards erected to shift the sand and prevent the railroad tracks from being covered. These barriers do not last long under such ruthless and persistent wear



**T**O make a successful fight against the ever-moving sand dunes of the Columbia River region and at other places along the Pacific Coast, the United States must follow the plan adopted by France many years ago. It must build one great dune in an effort to eliminate many smaller ones. This is the verdict of Forest Service experts who have made a world-wide study of sand dunes and methods employed to combat them. Since the planting of forests has been found to be the most effective means of checking the encroachments of sand the problem is one that comes within the jurisdiction of the United States Forest Service.

In the lower Columbia River valley, both in Washington and Oregon, sand dunes are destroying farms and orchards and are changing country of great fertility into waste land. Bearing orchards have been completely engulfed by dunes and buildings have been buried to the roof line. Railroads have suffered heavily and have spent large sums in efforts to keep their tracks from being buried.

A hundred years ago France was confronted with a problem equally as

serious. More than 300 miles of coastline on the Bay of Biscay was being blown inland by the winds of the Atlantic Ocean. The most fertile portion of the country was threatened. Eventually some one hit upon a plan of building a great lateral dune along the entire coast as a means of checking the movement of the sand. About seventy years ago France set to work on this great task. She only started the building of the dune, however, when Nature took up the work and completed it.

The entire coast-line was fringed by a fence consisting of posts driven in the ground at close intervals, and the spaces between them were interwoven with willow branches and brush. Soon the strong winds blowing in from the ocean banked a great wall against this fence and eventually it was entirely covered with sand. Then a second line of fence was erected on the small lateral dune thus created. In time this fence was covered by the sand which banked up against it. This operation was repeated

The sand menace has disappeared, and it cannot return.

The situation on the Pacific Coast is similar in one respect to that which confronted France. The sand is blown inland by the high winds from the ocean. The situation on the Atlantic Coast is just the opposite, however. There the sand is blown seaward, by winds coming from the land.

In the Columbia River region the sand is much lighter in weight than the sand of the Atlantic Coast, due to the



Sand dunes about to engulf a small settlement

many times and then other means of increasing the size of the dune were used. Native grasses that thrive in sandy soil were planted along the top of the dune; this served to keep its height as uniform as possible by preventing the winds from carving indentations in the face of the pile. Pine trees were planted along the top. These served to check the wind-blown sand as the fences had done in past years, and day by day the dune grew in height and widened out. As it increased in size more pine trees were planted.

To-day a great forest 2,500,000 acres in extent fringes the coast-line as the result of this initial experiment. It represents France's greatest supply house of turpentine and lumber. The country lying inland from it is rich and fertile.

large quantity of mica which it contains. This makes it easily carried by the wind. It also gives it great fertility when once watered, so that with the reclamation of the sand dunes there are possibilities of cultivating profitable orchards and farm lands in connection with the belts of forest which will necessarily have to be established.

Many dunes in the lower Columbia River valley are more than thirty feet high, and several even more. The accompanying photographs illustrate some of the problems caused by the dunes. Railroads have spent thousands of dollars in rough fences, known as hurdles, in an effort to keep their tracks from being submerged. Irrigation ditches have been moved from time to time to prevent them from being filled with sand.

### Device to Hold Covers on Sleeping Child in Crib

SEW a one-eighth-inch wire to outside cover of bed—a spread or quilt or sheet. Sew a piece on each long side and on the short side at the foot of the

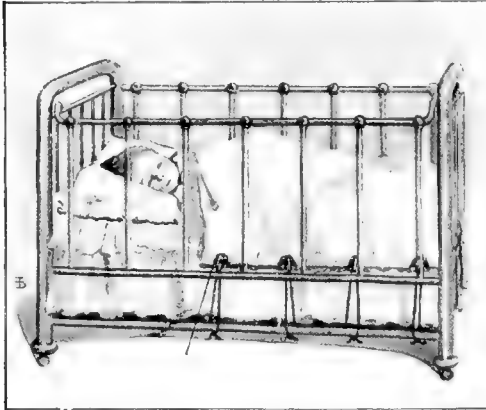

The most restless baby cannot pull this coverlet off because it is securely fastened on both sides

crib. Tie the wire with tape to the rod on the bedstead that parallels the wire. Small rings can be put on the wire about twelve inches apart if desired. To open covers, untie the tape.

The other covers are held in position simply by pinning them all to the top one in two places.

### The Motor-Cycle Street-Sweeper

AN innovation in street-sweepers has just appeared in Los Angeles, California. It is the combined invention of T. C. Girton, F. C. Hoffer and J. F. Smedley of that city and is a combination of an ordinary twin-cylinder motor-cycle and a sweeping apparatus. The engine in the motor-cycle furnishes the motive power by which the entire outfit is driven.

It is a one-man machine, while the gasoline, oil and brush, which are its only other continual expenses, are hardly large enough to be worth mentioning. It may be operated from two to twenty miles an hour, while at the eight-mile

speed it works best. It will do the work of about twenty men.

The front end is taken up by the sweeper mechanism, located in front of a pair of wheels, which, in turn are, practically speaking, in front of the motor-cycle proper. Both wheels and sweeper mechanism are fastened to the motor-cycle by means of an angle-iron frame, the operation of the wheels being controlled by the handlebars. The brush, which is about sixty inches in length, is immediately in front of the pair of wheels and is operated by a lever at the side of the driver, who, by pushing one of the levers forward raises or lowers the brush at will. The cylindrical sheet-iron drum, with an apron attached, is suspended just in front of the brush. Over this apron the dirt is swept into the drum, the brush being chain-propelled by the engine of the motor-cycle.

By pressing forward another lever the driver is able at a moment's notice and without dismounting to turn the drum, which has a capacity of about four bushels, so that its contents will fall in a pile upon the street.

Provision has been made for this sweeper to carry along its own dirt-wagon. This is done by simply

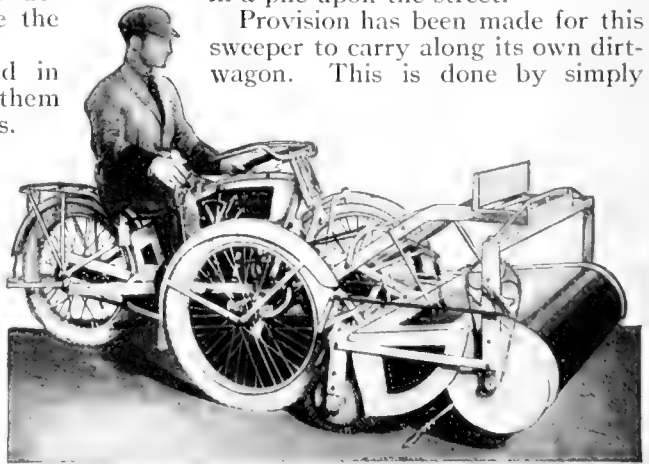

This machine sweeps a street without creating so much dust as a hand sweeper

fastening that part of the outfit to the rear of the motor-cycle. If at any time the sweeper mechanism should give any trouble, the simple pushing forward of a lever at the driver's side lifts a metal tray which covers the brush and receiving side of the drum, placing it immediately open for examination.

### A Luminous Life-Belt for Rescue at Night

**T**WO electric flash lamps wrapped in a casing impervious to water can be attached to any one of the several types of life-preservers and be made to light a person in the water at night and thus facilitate rescue. Furthermore, the lamps may be so constructed that in case it is desirable to throw overboard any type of buoyant life-preserver, the lights may be switched on immediately before casting on the water, so that a person in danger of drowning can see his way.

The preserver may be fitted with one or more lamps, as desired. Surrounding the holder is an impervious sack or pocket, preferably of rubber, and provided with an elastic beaded mouth adapted to be tightly fitted around the lamp-holder below the lens in such manner that water will not enter. On the sides of the pocket are formed loops acting as securing means for straps provided with buckles and tongues. Once the straps are firmly clasped around the preserver the lamps are held rigid. An open space is allowed so that the lamp switch may be operated.



The life-belt consists of a preserver with one or more lamps rigidly fastened in position

Where landings are particularly dangerous at night motor-boat parties have used the luminous life-belt to illuminate the water and determine the safest place to dock. The belt is thrown overboard when the boat approaches a landing place and serves admirably as a buoy light.

### Seeing Yourself as the Oil Well Sees You

**T**HIS photograph of an oil derrick is about as unsolvable a puzzle picture as is often seen. Were it not for the

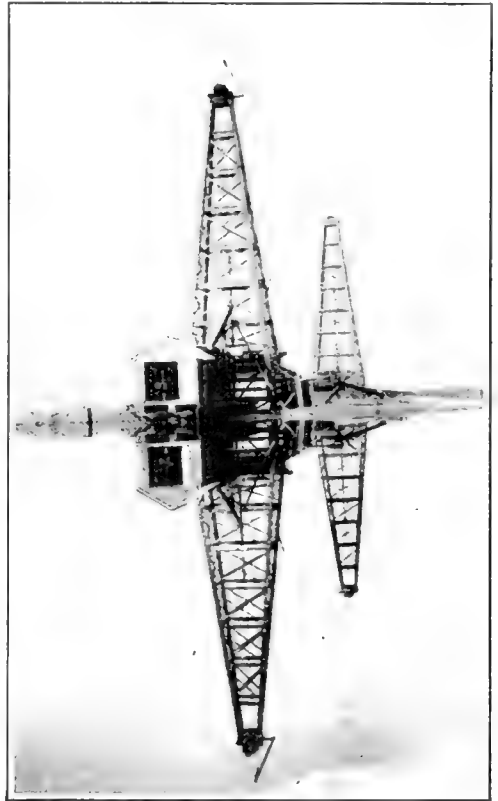

We leave this to you. Is this photograph upside down or not?

grass and shadow of the lake bank in the foreground it would be impossible to tell which was the top and which the bottom of the picture. Or, if the picture of the smaller or more distant derrick to the right is considered alone, no one can tell the reality from the reflection. The reason for this absolute perfection in reflection is that the lake is of oil.

In the great southern California oil fields, where gushers are being struck which flow from ten thousand to sixty thousand barrels of oil a day, and flow continually every minute of the day and every minute of the night, the only possible way to save the oil is to quickly throw up an emergency earthen dam across some convenient ravine and turn the oil flow into the reservoir formed.

# A Photographic Eye for the Airman

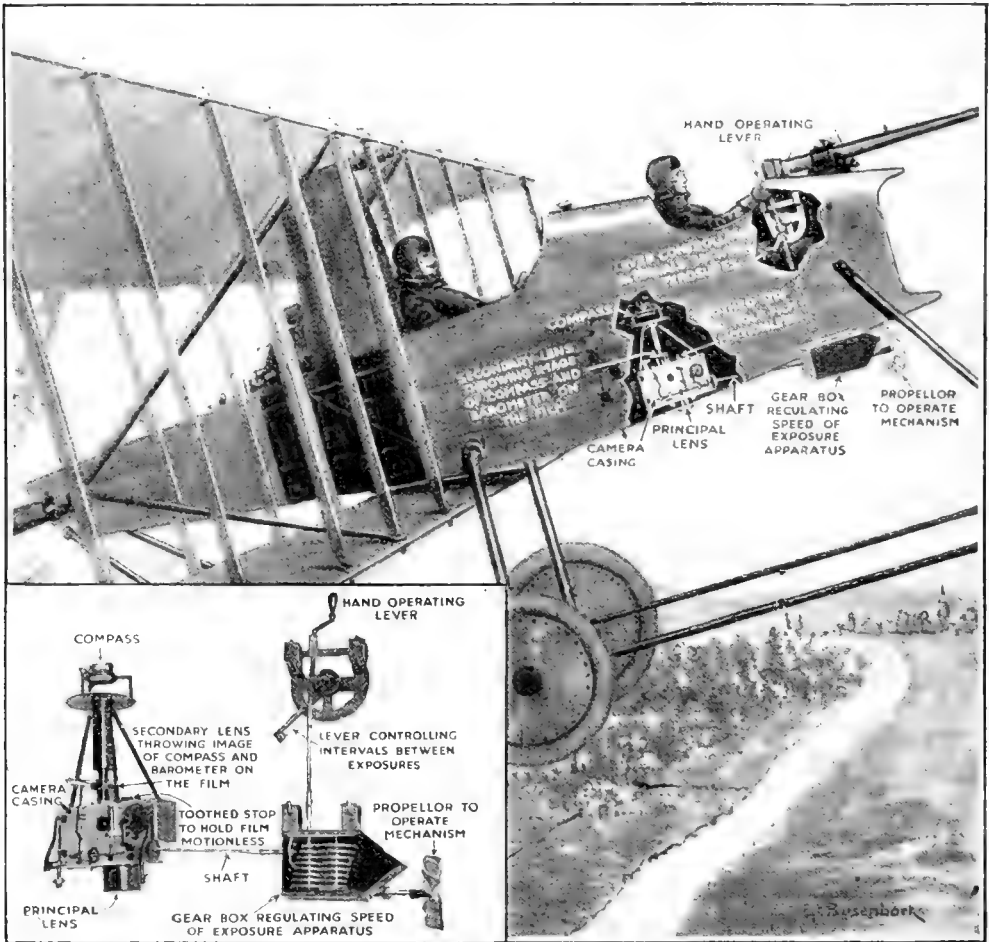

With this camera apparatus every detail of the world below the airman is minutely registered on the roll of film which runs over the camera lens at a speed regulated by the operator

**G**REATER progress has been made in aerial photography during the present war than in the years following 1858, when M. Nadar, of Paris, took a view of that city by means of a camera attached to the basket of a balloon. The fact that a photograph from an aeroplane of fortifications, damaged railways, bodies of troops, and the contour of the enemy's country gives valuable information which is absolutely reliable, not being dependent for its accuracy on the skill and coolness of the observer, makes this form of reconnaissance of the highest military importance.

Indeed, it is of such value that a dozen

different types of aerial photographing apparatus have been evolved in the short duration of the present world struggle. The latest development is found in the Fabbri automatic aeroplane camera, which includes some features already tried out by other inventors but which is, in the main, an ingenious mechanism of original construction. With it an aerial scout can take a continuous photograph of the earth's surface one hundred and thirty miles long. When operated on an aeroplane at an altitude of two thousand feet it will take into its field a strip of ground one thousand two hundred feet wide. In clear weather excellent work

can be done at four thousand feet, in which case the width of the field is about two thousand, four hundred feet.

Suppose a scout is given orders to photograph the entire territory occupied by the enemy. He regulates his camera, soars aloft, and when over the enemy's trenches at an altitude of two thousand feet, for instance, turns a lever which releases a propeller in front of a gear box, which, in turn, starts the camera mechanism in motion. Instantly he obtains a continuous photograph of the earth's surface one thousand, two hundred feet wide.

Should he desire to get more useful information by continuing his flight at a higher altitude, he stops the camera mechanism and ascends to twice the height. There he makes a readjustment of the apparatus and continues his flight, taking a continuous photograph meantime. Mile after mile he continues, until, if he so wishes, he can obtain a photographic record of one hundred and thirty miles of the enemy's territory.

Briefly, the camera consists of a camera box containing two rollers round which the film is carried. The film has a series of perforations along one edge, and a toothed stop is provided to engage with these and hold the film motionless when required. The box is impervious to light, and has a lens pointing downward, through which the main photograph is taken. It has also another lens pointing directly upward, which produces photographs at desired intervals of the exact position of the compass and aneroid needles situated in the holding case above. This last-named photograph automatically registers on the film the direction and altitude of the aeroplane when the exposure was made.

The film rollers are driven by a propeller through the gear box. The hand lever controls the intervals of exposure by varying the speed of the shaft as compared with that of the propeller. The shaft may be operated by hand through the lever and a single photograph be taken, the propeller being for the moment put out of gear.

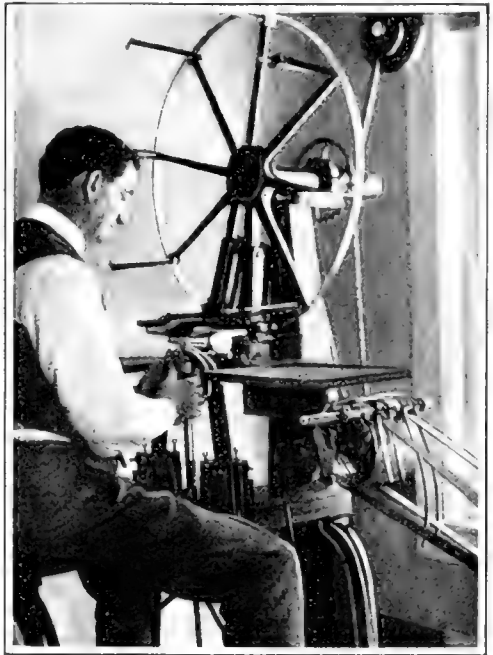

The ingenious baseball sewing-machine which pulls the covers together and stitches them

### A Machine That Stitches Baseball Covers

**A** SEWING-MACHINE has been invented for stitching together the covers of a baseball. It has a mechanism for holding the ball in position while it is being stitched and pulls the covers together over the ball while the stitch is being taken.

The clamping jaws hold the ball while a wheel above is turned to bring its needle gripping fingers into position to outwardly grip and release the needle which sews the covers. A cam device regulates the needle action.



This can will trap every inquisitive animal that sticks its head into it

### Trapping Animals by "Canning" Them

**A** FIVE-gallon gasoline can cut at the top from corner to corner and with the sharp edges bent inward, constitutes a trap for animals that never fails to work. When the animal enters the can with its head the sharp edges prevent it from extracting it and escaping.



# Charting the Dangers of the Deep

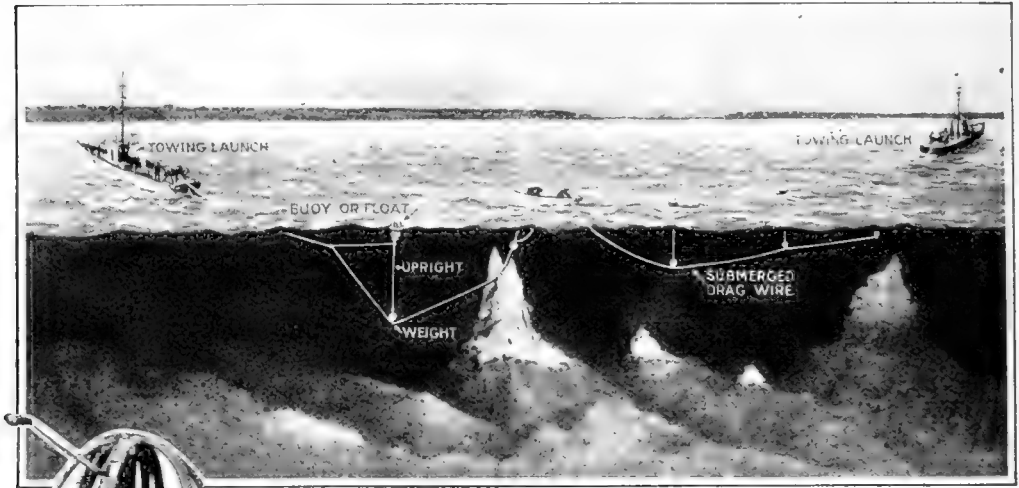

Disentangling and measuring the depth of the submerged wire-drag after it has struck an uncharted rock. With the lead line the discovery of this rock would have been more or less a chance. At left, the buoy or float with the upright and weight attached

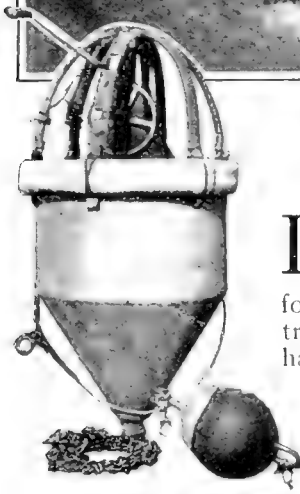

**L**AST summer a submerged rock was found at the entrance to Boston harbor, close to which one or more of our ten-million-dollar super-dread-noughts had

repeatedly passed under the supposition that the water was forty-five feet deep, whereas it was actually only twenty-three feet deep. Before that a rocky pinnacle was discovered in Alaska waters, higher than the Washington monument, lying directly in the steamship lane. Only seventeen feet of water covered it. These are striking examples of the valuable service rendered the world's shipping interests by the United States Coast and Geodetic Survey.

No one branch of the Government plays a more important part in the welfare of the country than the Coast Survey. It is not only the oldest scientific bureau in the Government, but the oldest bureau of continuous service. Although its chief work is defined as the making of navigational charts of the

United States and outlying territory, the Coast Survey gives the man who follows the sea a complete knowledge of the coast, its nature and form, the character of the adjacent sea-bottom, the positions of reefs, shoals and other dangers to navigation, the rise and fall of the tides, the direction and strength of the currents and the character and amount of magnetic disturbance.

The chief operation in a hydrographic survey is sounding. A hand line or a sounding machine is used, depending on the depth of the waters, but the comparatively recent wire-drag, introduced by French hydrographers and since developed and improved by the Coast Survey, has revolutionized hydrographic surveying. The wire-drag was first used on the Atlantic Coast in 1906, and from that time to the present one thousand, six hundred and sixty square miles have been dragged and about five thousand shoals examined. On the Pacific Coast this work was undertaken in 1914. Probably one-half of the shoals examined had less depth than charted.

On a mariner's chart the line of soundings with the lead is represented by a row of figures spaced more or less closely together, and with the rows of numerals



representing depths spaced more or less widely apart, according to the depth and nature of the bottom. If the depths are great and the bottom of sand or mud, the lines and soundings are wide apart. If the depths are not great and the bottom rocky and broken, the soundings are closer together; but there is always a considerable interval between the lines of soundings and between the individual soundings. The soundings represent only the depth over a space of a few inches where the lead touched bottom. It is between the soundings that the danger may lie.

Thus, in the closest survey, large spaces are left, over which the depths are not absolutely known. Jagged pinnacles of rock projecting from the bottom may rip open the plates of a passing vessel. The projecting masts of a sunken wreck may be a menace to the navigator, although not visible above the surface. The lead may slide off a precipitous rock and give no indication of the true depth. A line of soundings has but one dimension, length. The wire-drag line has two dimensions, length and breadth. For every mile of distance dragged every danger in a square mile of area is detected with absolute certainty.

With the lead line their discovery is more or less a chance, and it is difficult and often well nigh impossible, to find a rock or shoal of small extent even when its approximate position is known. The vessel searching for it is as apt to run against the obstruction as to find it by sounding. With the drag such a danger cannot escape. Hence it is the only means of finding all submerged dangers in certain areas. Safety of navigation can be assured by no other means.

The wire-drag is operated in the following manner: A horizontal wire supported at any desired depth in the water by a system of uprights attached to floats at the surface and held down by weights, is drawn through the water by power boats. Any rock or shoal projecting from the bottom above the effective depth at which the drag is set is caught by the wire. Soundings are then taken over the spot, and its position is located by angles taken to previously determined points on shore. The soundings are afterward plotted and placed upon the charts. In practice the drag has developed into a somewhat complicated mechanism, but in emergencies a simple form of drag may be readily improvised. Modified forms of the drag have been used for finding and removing mines, and for locating sunken wrecks and buoys.

It is obviously adapted to many such uses.

The average cost of a wire-drag party is thirty thousand dollars, based on a season's work of from six to eight months. The cost per day is about two hundred and fifty dollars.

Some idea of the importance to this country of surveys of its coasts may be gained by recalling to mind that the coast line of the United States and Alaska, measured along its general trend, exceeds eleven thousand five hundred miles in length. To represent

the actual shore line which must be surveyed and which includes all the islands, bays, sounds, and rivers in the tidal belt, these figures reach the large total of ninety-one thousand miles; and to this must be added the shore line of Porto Rico, Guam, Tutuila, the Hawaiian and the Philippine Islands, whose coast line is twelve thousand statute miles.

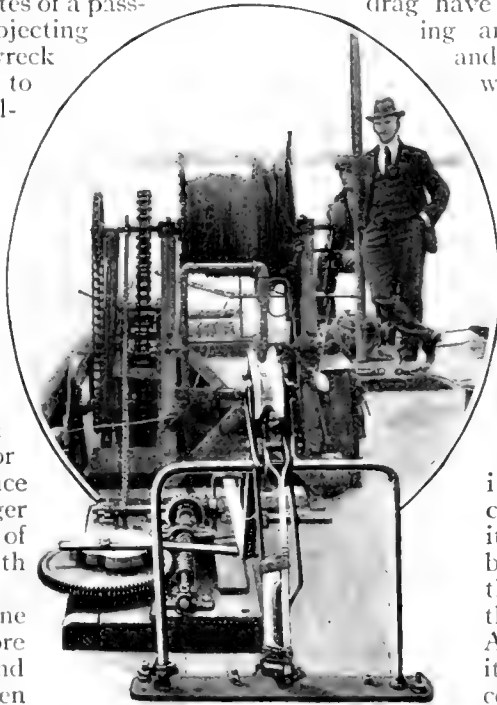

The hoisting and measuring equipment on the towing launch

# Coaling a Liner with an Elevator

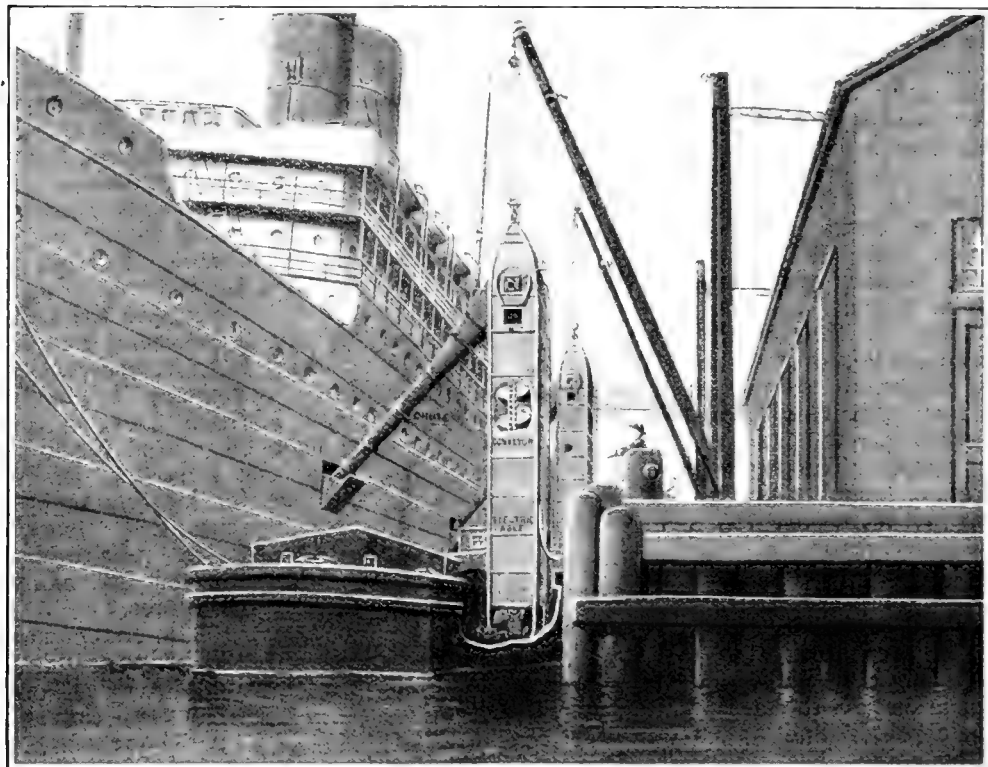

An endless bucket-chain passes into the barge and thence up the conveyor to the discharging point at the top of the chute. This loader has coaled the "Vaterland" in twenty-one hours

**S**PEED and certainty are the two principals upon which the great steamships which ply between continents are operated. They are permitted only a limited number of days in port; they must be swiftly unloaded and cleaned; and they must be no less swiftly loaded, and made ready for sea. In all these operations, the machine which is in greatest demand is the one that can put the cargo aboard in less time and at less expense than another machine. Especially is this true in taking aboard coal. The ocean greyhounds which carry from five thousand tons to nine thousand tons of coal, and which are permitted only two or three days to take on such an immense cargo, must therefore be loaded in the most rapid as well as the most economical way.

Coaling ships by the old-fashioned hoist-operated tubs was a slow and

expensive process. An apparatus was therefore made necessary which would reduce the coaling period, require less space, cut down the labor and maintenance costs, and eliminate the nuisance of flying coal-dirt. The machine that was invented with these objects in view is seen in the illustration loading coal from the barge into the port-holes of a large ocean liner. Each of these loaders can be suspended from a boom by means of a rope and pulley, over any barge, and inasmuch as they are truly portable, they can be swung from any portion of the ship to the desired loading point. Herein lies their advantage over the floating unloading elevators which require a large water space, and have but one point of delivery.

The driving-motor is installed in the head of the elevator, and is operated by electric current supplied from shore.

The starting and stopping of the elevator as well as the hoisting, shifting, and lowering of the unloaders is controlled by two men, one on each side of the vessel. On very large liners as many as twelve or fourteen of these electric loaders are employed for rushing the coal into the holds of these impatient monsters. And even when a fresh bargeful of coal is brought up, there is no delay in the operations; the loaders are simply raised and swung over the coal in the barge, and the loading continues.

What contributes most essentially to the effectiveness of these portable loaders, is the fact that they are self-contained. Within the elevator, steel buckets are connected with rolled steel hinge-pins, so as to form an endless chain. The chute, on account of its telescopic construction, is adjustable to the desired

length, and distribution is thus made flexible. Such floating marvels as the "Imperator" and the "Vaterland" have been coaled by these loaders in twenty-one hours, during which eight thousand five hundred tons were put aboard by ten such machines—a performance that could not have been achieved by the old-fashioned system of hoisted buckets.

Any bulk material, such as sand, gravel, or stone may be loaded or unloaded from one point to another, rapidly and economically. These electric loaders are used to transport a cargo from a freight-car into a truck; or from a barge into storage bins. And when one considers that none of the material loaded is lost, and that the skilled labor of an engineer or his assistants is not needed to operate this device, its claim to economy becomes undeniable.

## An Auto Mountain Railway

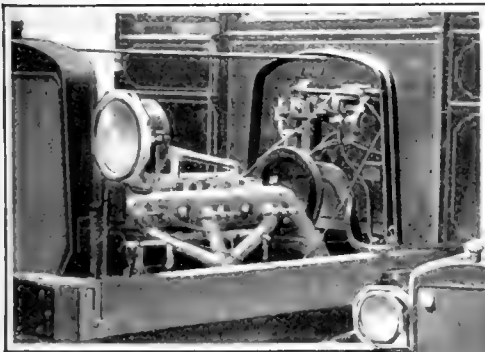

Above, the automobile engine mounted in its accustomed position. At right, the railway car with the low-slung body on car-wheels. There is enough room in the tonneau for twenty people, besides the chauffeur-motorman

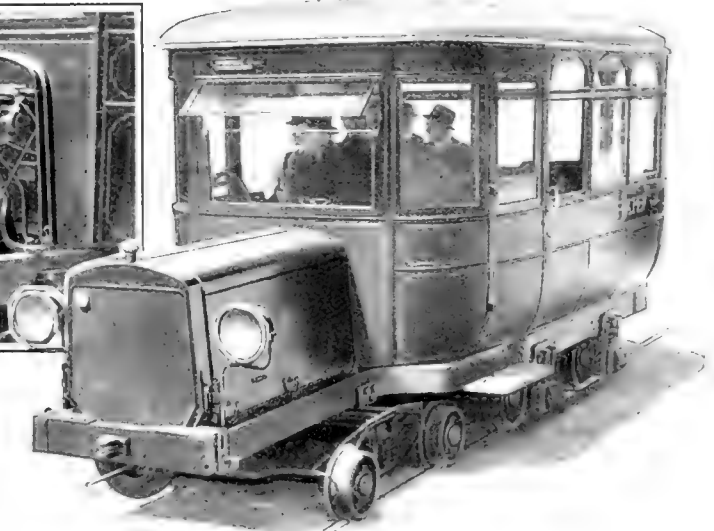

**F**OR the transportation of passengers up Mount Tamalpais in California a number of automobile railway cars of unique design have been devised. The cars are propelled by a sixty-horsepower, water-cooled engine, and there is room in the spacious tonneau for twenty people, in addition to the driver.

The chassis, which is of special design, is mounted on railway car-wheels form-

ing four trucks in all. A special gear-reducing mechanism cuts the speed of the engine down to where it is most efficient for climbing steep mountain grades. The seats are upholstered similar to those in railway cars, and everything possible has been done to cater to the comfort of the passengers. It is said that this method of transportation has enjoyed great popularity.

## Experimenting with Liquid Fire



C. MEDICAL PHOTO SERVICE

The deadly effects of liquid fire — a formidable factor of the present European conflict — are here being tested. The apparatus is strapped to the shoulder and the liquid is ejected through a hose

# Tasting the Fruits of Victory



at St. Eloi. The soldiers are members of the British "Fighting Fifth." There are more than the French helmets. The weapons displayed are captured trench guns

A few minutes after the capture of the German trench they are wearing the new English steel helmets which are flatter

© 1918 by  
The Associated Press

# What Chemical Energy Can Do

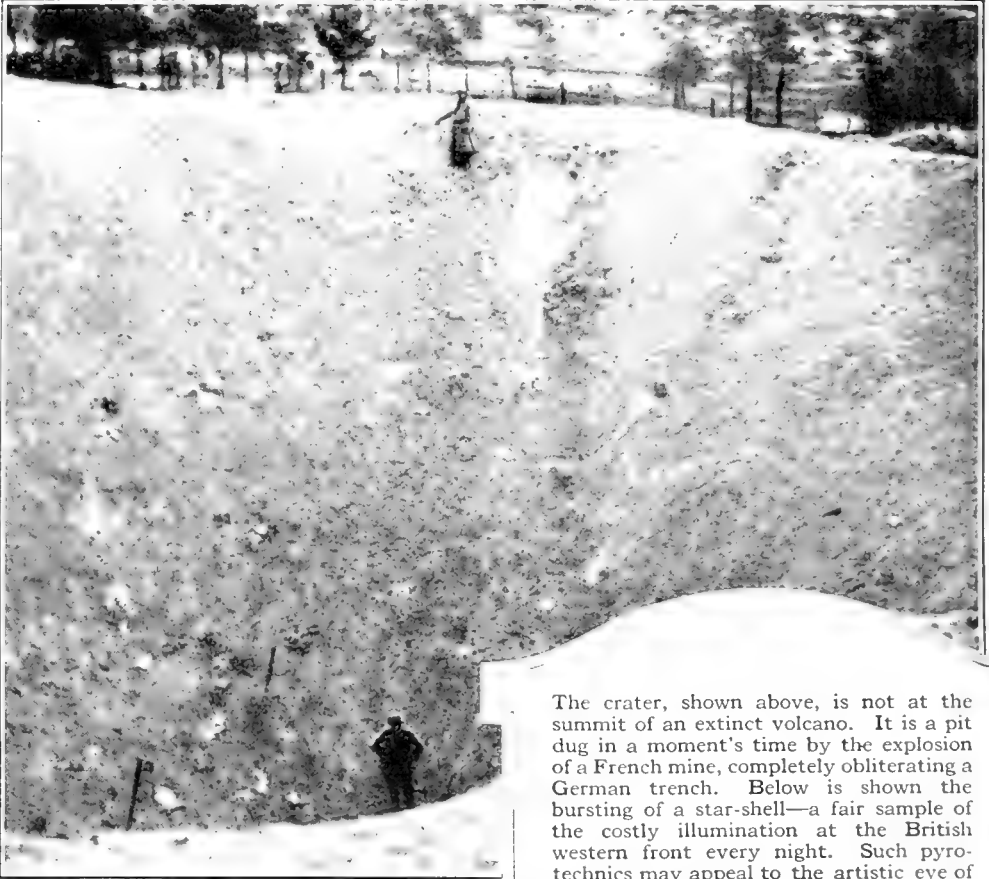

The crater, shown above, is not at the summit of an extinct volcano. It is a pit dug in a moment's time by the explosion of a French mine, completely obliterating a German trench. Below is shown the bursting of a star-shell—a fair sample of the costly illumination at the British western front every night. Such pyrotechnics may appeal to the artistic eye of the non-combatant but to the soldier they mean but one thing—a night of terror

© Int. Film Serv.

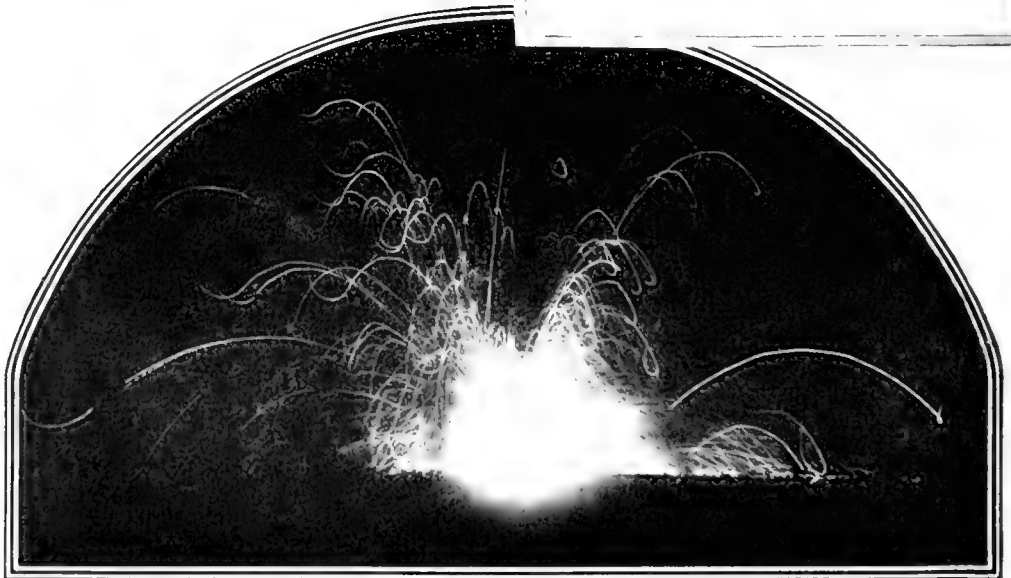

© American Press Association



# Infernal Devices of War-Crazed Men

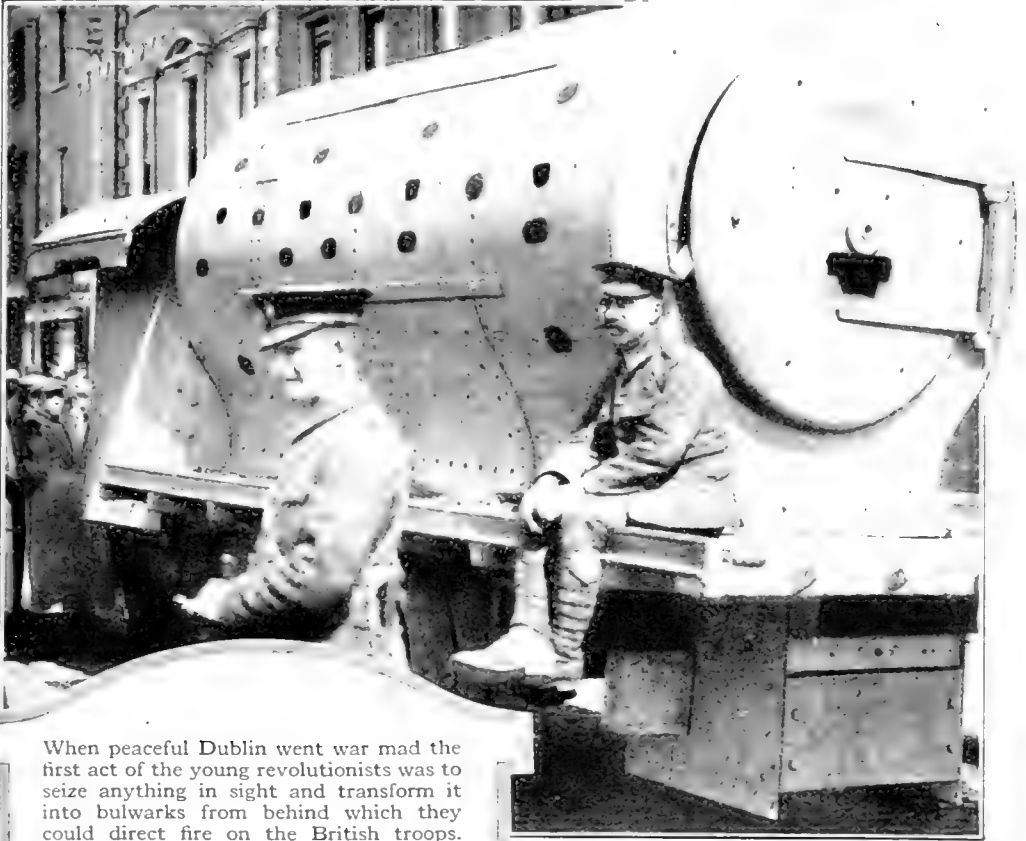

When peaceful Dublin went war mad the first act of the young revolutionists was to seize anything in sight and transform it into bulwarks from behind which they could direct fire on the British troops. The photograph above shows an armored motor-car made from a discarded locomotive smoke-box. Below are shown two Italian motor cannon-turrets. They are provided with "feelers" to cut through wire

American Press Association

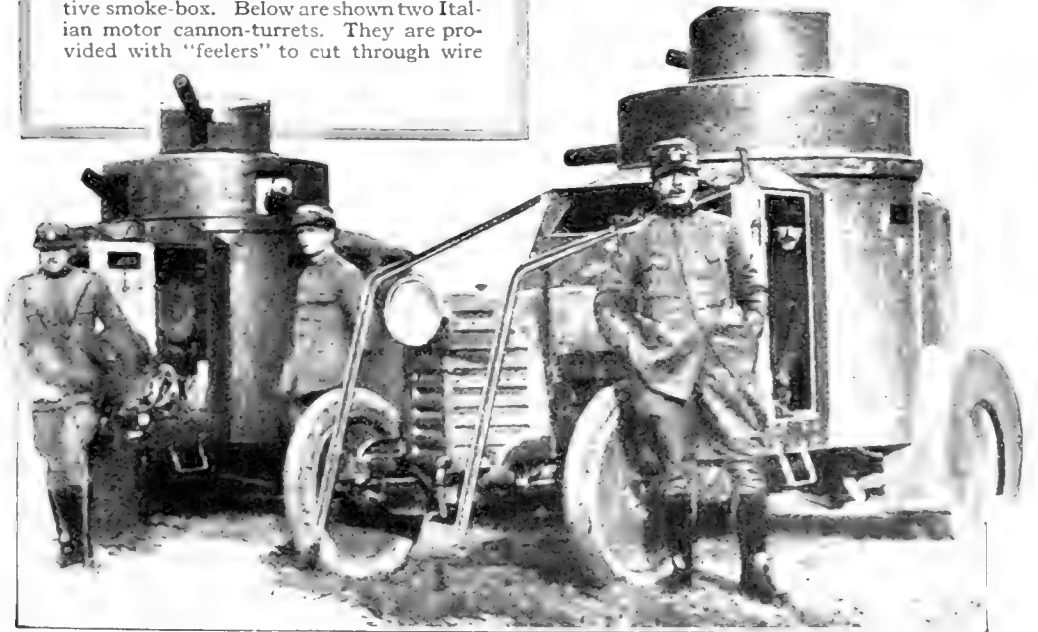

## Another Death in Germany's Aerial Family



©Int. Film Serv.

The Zeppelin L 20 wrecked off the coast of Norway. It is said to have been one of the five or six Zeppelins which took part in the raid on the East Coast of England the night of May 2. It was driven about by the wind and finally settled in the water where it broke in two and sank. The crew escaped by jumping just before the cabins struck the water



©Int. Film Serv.

A view of the Zeppelin shortly before it sank. The afterbody broke just ahead of the aftercabin and disappeared. When the big ship hit the water the wind soon buffeted it about so roughly that it was torn to pieces. A shortage of fuel is said to have caused its loss



# War Machines of the Atmosphere



© Topical Press

The boat-like after cabin of a Zeppelin, showing the spacious quarters for the crew

A powerful aeroplane motor which has just arrived in a French camp in Macedonia, being tried out by aviation officers prior to its practical war service

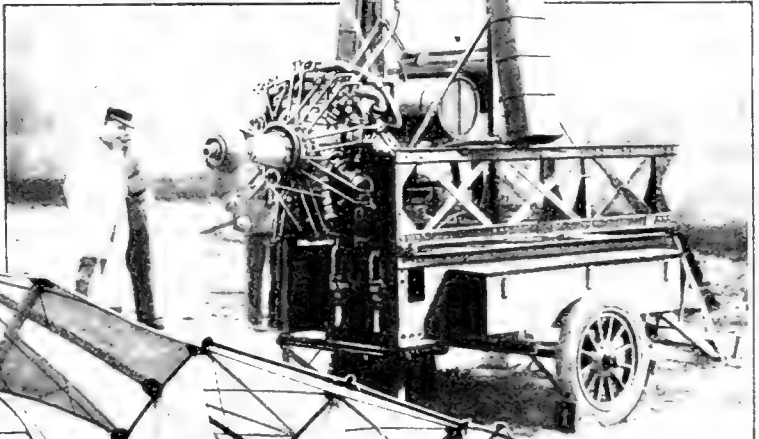

Photos © Underwood and Underwood, N. Y.

French soldiers about to raise a complex observation kite at the Verdun front

# Animals Highly Valued in War



© Underwood and Underwood, N. Y.

Mules are treated with great care in Albania and are carried across deep streams on ferries. Horses swim their way across



A trainload of camels leaving Cairo for the western frontier of Egypt, where they constitute the Imperial Camel Corps

© Int. Film Serv.

# British Balloon for Reconnoitering in Greece

A British kite-balloon on the balloon deck of a war transport. On the right is a wind screen and in front is a special sliding platform to facilitate the movement of the bag. The balloon is carried in the hold of the ship and is released when conditions are favorable for reconnoitering



The illustration below shows a kite balloon rising from the deck of its transport to make a reconnaissance tour of the country surrounding Salonika. The balloon is invisible to enemy airmen when it is being transported from place to place in the vitals of the big war transport

Photos © Int. Film Serv.



## Science Is Terrible, When Applied to War



© Int. Film Serv.

Above, one of the big anti-aircraft machine guns mounted on a motor-truck trying to get the range of an enemy air-raider. The concussion of the gun when fired is slightly overcome by an iron beam underneath the rear of the truck. The beam is equipped with jacks on either end to clamp it securely to concrete blocks carried for that important purpose



At left, a piece of a 15-inch shell from a British battleship. This gives a fairly accurate idea of the hugeness of these shells and the destruction they can cause when they strike to the heart of a target. In the recent naval battle between the high-sea fleets of both England and Germany these shells were fired with abandon at a range of miles

## Economy Born of Necessity

A group of hungry people around a soup caldron in Berlin waiting their turn to procure their portion of soup which is sold for thirty-five pfennings (about 8½c.) a helping



At right, stripping a Berlin building of copper for ammunition purposes. The thrifty German hausfrau long ago contributed her copper cooking utensils to the country's cause

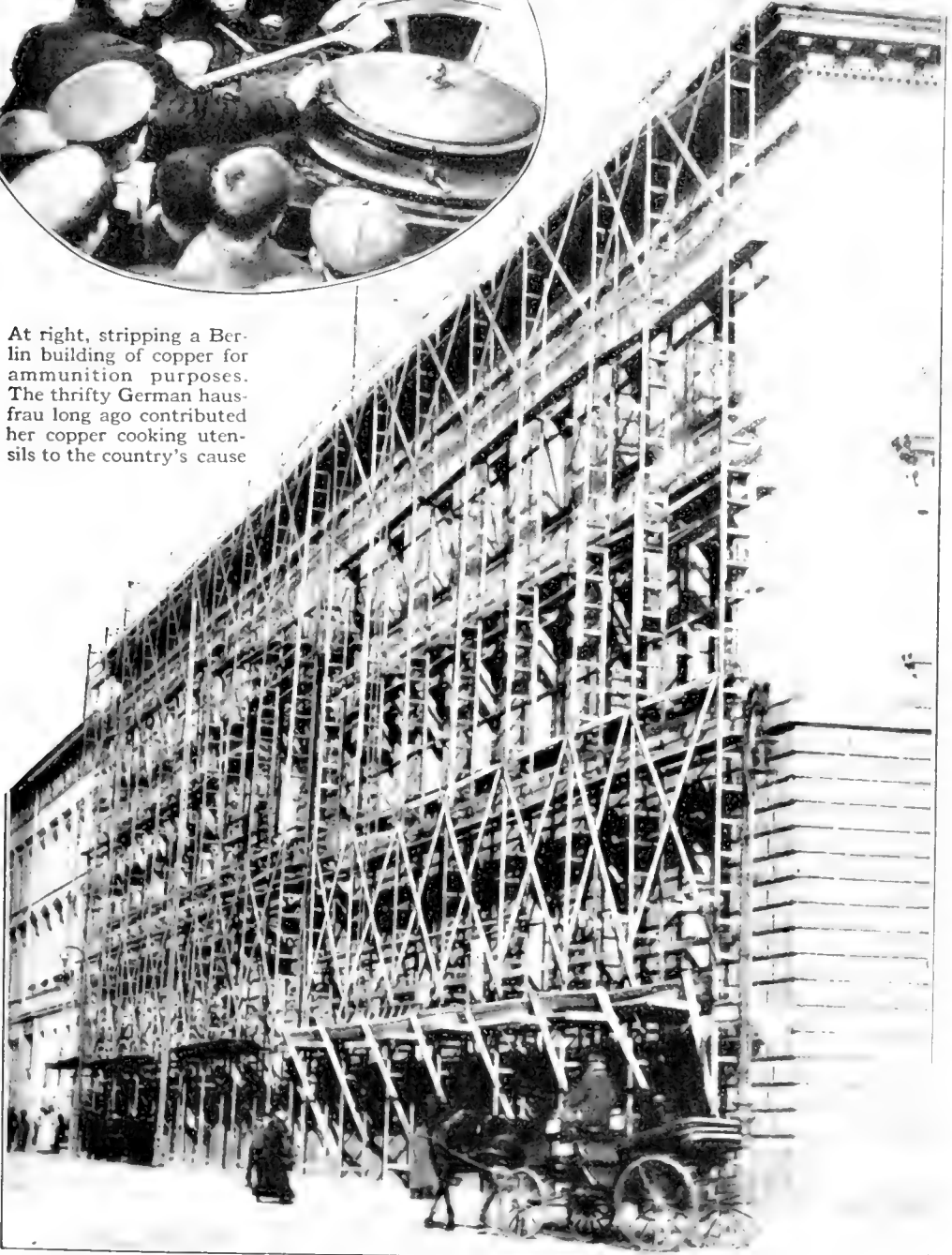

# Meeting the Exigencies of War



Wounded Tommies who will fight the battle of life hereafter with artificial limbs held an athletic meet at Rotherham recently. This fellow's right leg below the knee is artificial, but he cleared the chair with ease

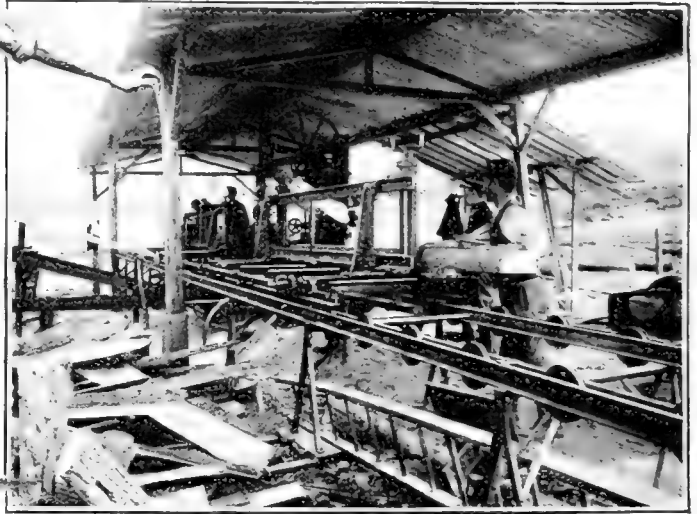

Above, a hastily constructed saw-mill behind the French trenches. Here lumber is cut for the various uses of trench life. Impromptu huts are built of it and it is much in demand for mining and timbering the dugouts which are in French hands today but which may be German inhabited in another twelve hours



Above, running a hundred yards in thirteen seconds with an artificial right leg. This man did the trick after jumping over a half-dozen chairs, one after another. Commuters who make a business of running for trains would be proud of this record



Above, burning wood for charcoal. This is supplied to the cooking staff for the baking ovens and to the soldiers in the trenches for use in the little stoves which have proved to be great comforts. A "stump-burner" has been devised which is set over a stump and a burning process carried on for ten hours which reduces the stump to charcoal and heavy oils



# Our Boys in Mexico

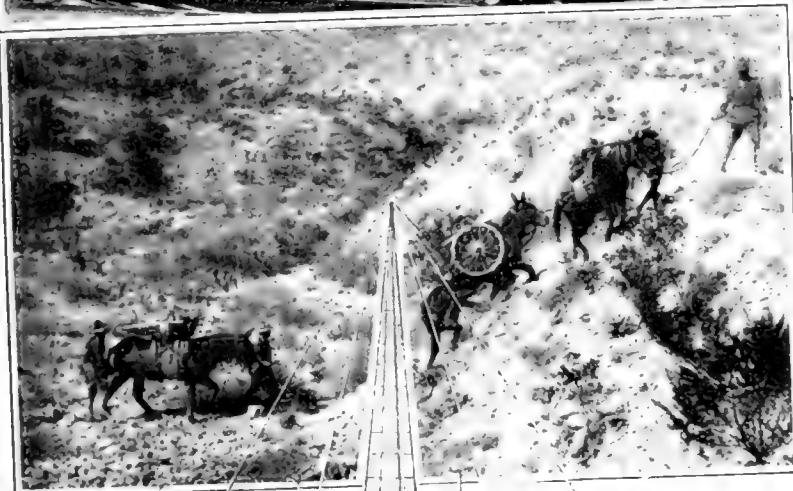

© International Film Service

More American troops arrive at the border to take the place of those sent on with the Punitive Expedition into Mexico. At left, transporting United States artillery and supplies over Mexico's roadless hills

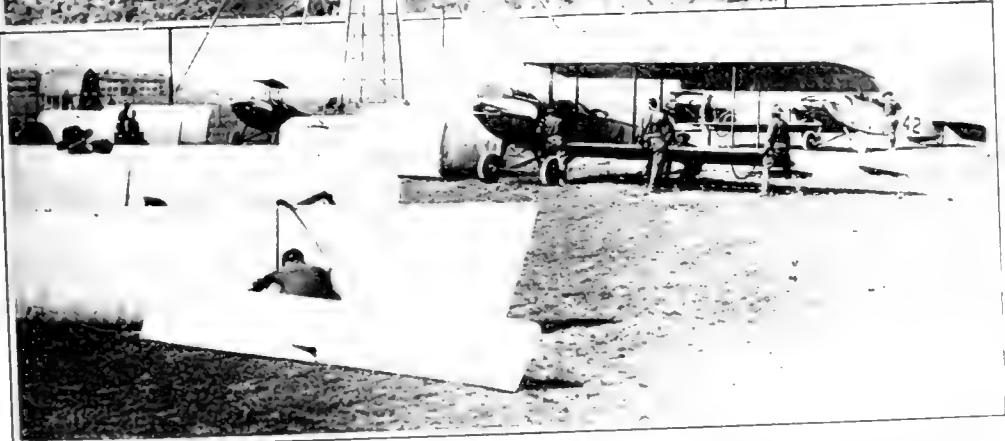

© Underwood and Underwood, N. Y.

Dismantling the First Aero Squadron for shipment to the border. Within a few weeks this squadron was again dismantled—hopelessly. Of our light aeroplanes, not one remained in flying condition. A few more machines were sent to take their places, but the entire Aero Squadron is composed of a fewer number of machines than is destroyed in a week's warfare in Europe. It must be said, however, that our fliers have accomplished marvels with their limited resources. From the first they have carried important dispatches between headquarters

# Our Man-Hunting Expedition in Mexico

Below, a group of youthful soldiers who are doing their part to capture Villa. A large part of the expeditionary force is now made up of young men like these

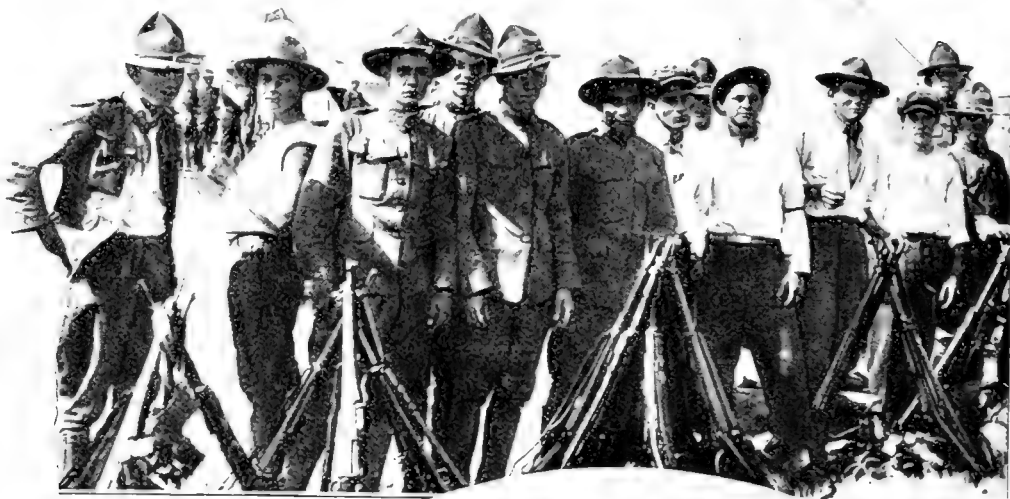

© Underwood & Underwood, N. Y.

At right, one of the repair shops on wheels in Mexico. A complete lathe and turning equipment is operated by motor and dynamo, driven directly from the automobile engine

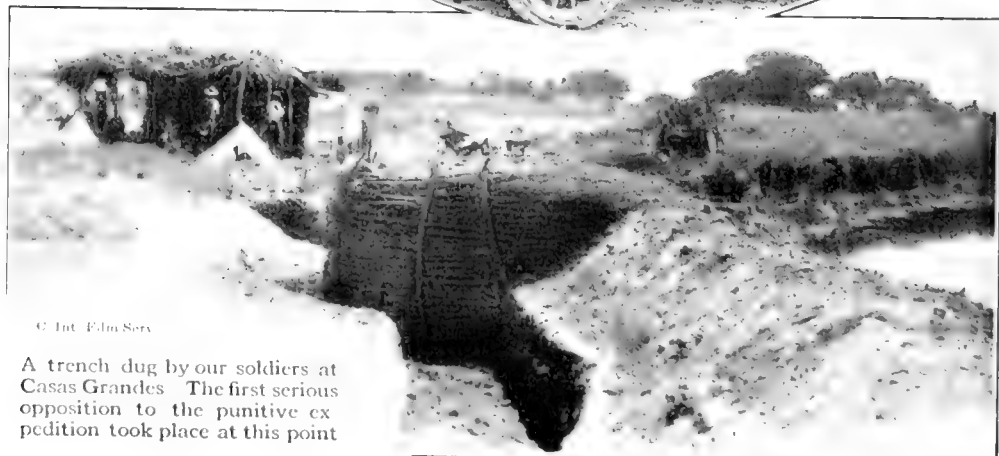
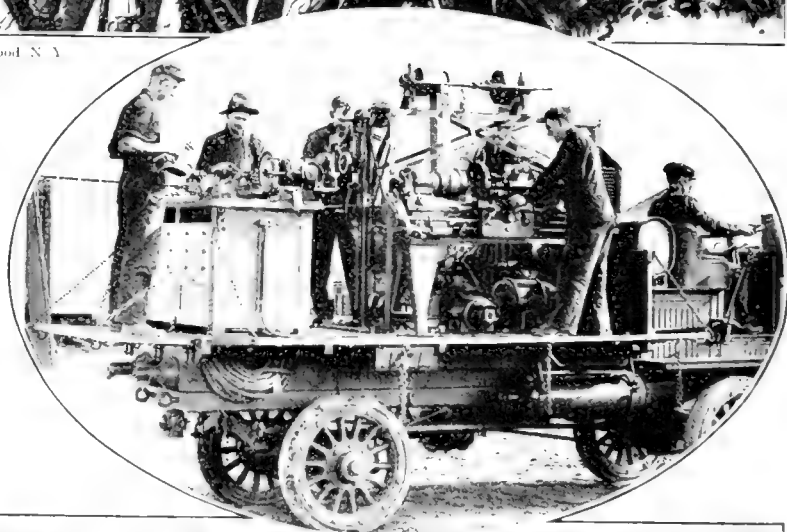

© Int. Film Serv.

A trench dug by our soldiers at Casas Grandes. The first serious opposition to the punitive expedition took place at this point



# Which Is Rounding Out Its Fourth Month



Above, Company D of San Antonio, Texas, on Mexican soil. Outside of Villa himself the Mexican most fears his Texas neighbor to the north

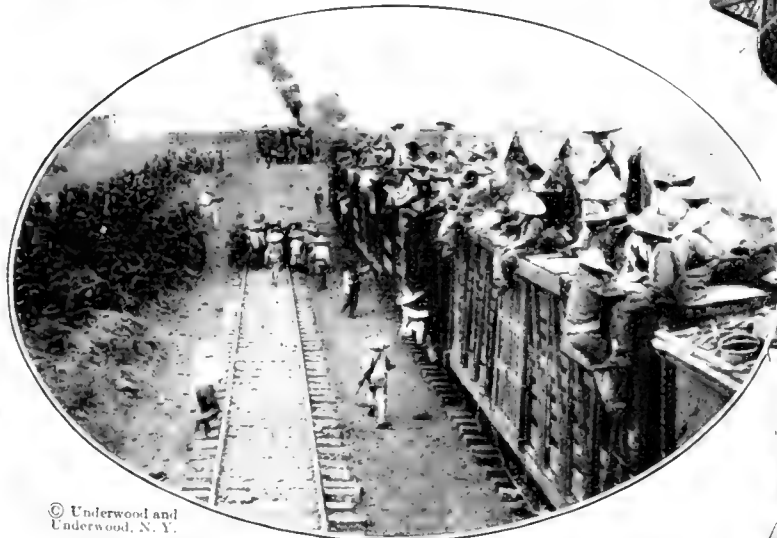

© Underwood and Underwood, N. Y.

Above, Carranzistas boarding the train near San Antonio in their puerile search for Villa. At right, Uncle Sam's latest field searchlight on a telescoping tower

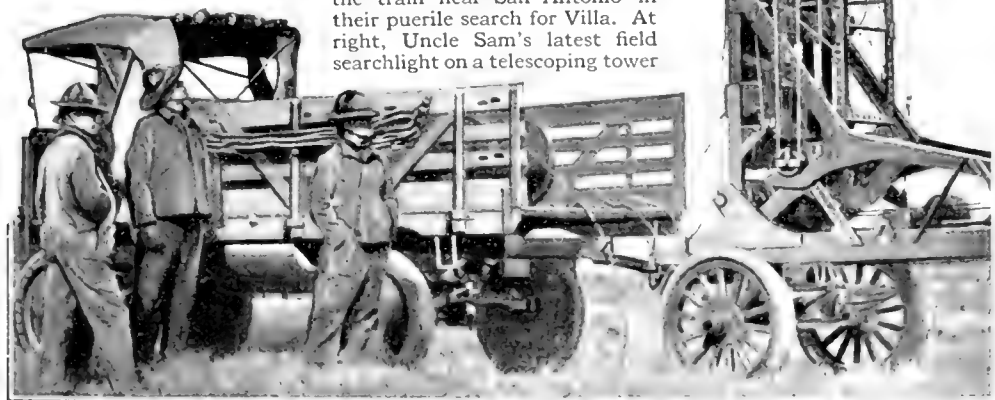

# Exhibiting Our Army's Efficiency at the

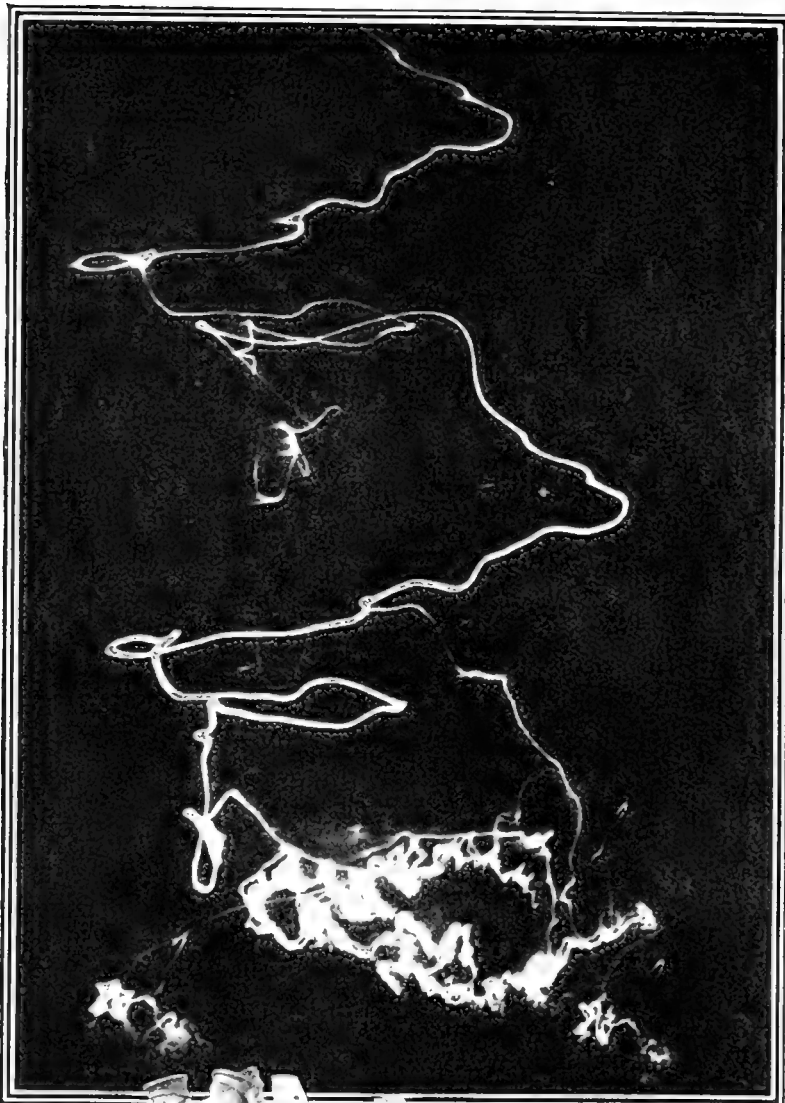

A daring girl aviator, Miss Katherine Stinson, performed several tricks in a night aeroplane flight at Sheepshead Bay, New York. She dropped a number of bombs which exploded a thousand feet over Coney Island to give the pleasure seekers all the thrills of a real bombardment. Two bomb explosions show in the lower left-hand corner of the illustration

The first armored motor battery presented to the New York National Guard received its initial tryout at the Sheepshead Bay Tournament recently. Before a great assemblage of interested spectators the battery crew gave an exhibition, firing the guns and going through maneuvers which would be expected of them in actual war

© Int. Film Serv.



© Underwood and Underwood, N.Y.

# War Maneuvers at Sheepshead Bay, New York



©American  
Press  
Association

At the Sheepshead Bay Army and Navy Tournament Rodman Law exploded his balloon with a stick

of dynamite and descended safely to earth in a parachute

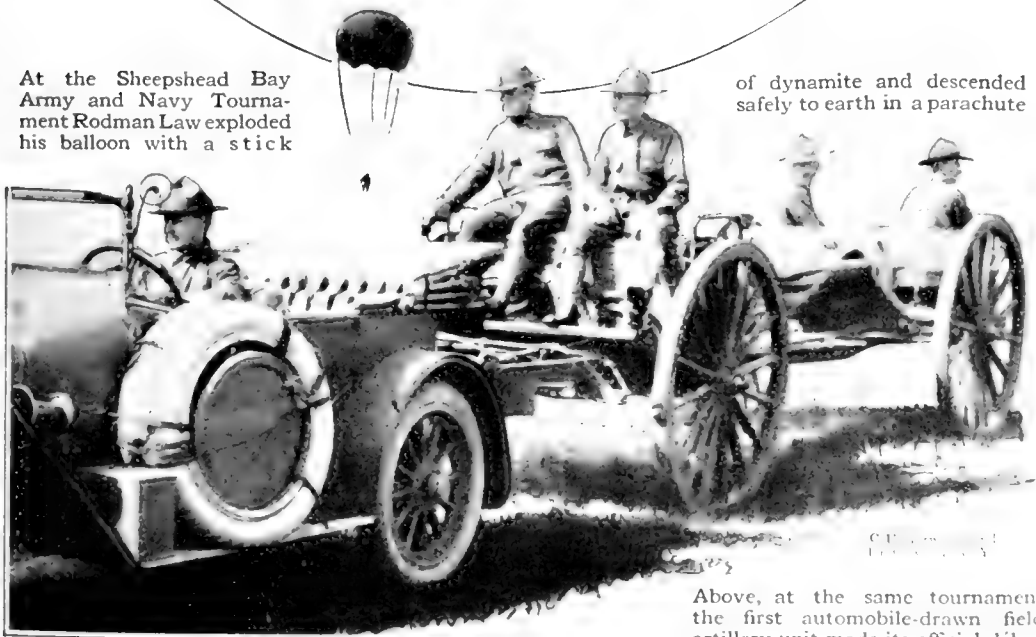

Above, at the same tournament the first automobile-drawn field artillery unit made its official debut

### Turning Your Racket-Press Into a Camp Stool

A CASE or press for a tennis racket that may be turned into a seat or stool at the discretion of the player is the invention of an Illinois man. The idea is to utilize the press as a seat in addition to its being used as a frame for the racket to hold the latter in the proper position to prevent it from warping.

Eight bars depending from the press are the legs for the stool device and when spread they afford a seat strong enough for the heaviest man. The apparatus is so arranged that the legs can act as supporting posts for the racket when it is held in an upright position on the ground.



The press may hold the racket or be spread out as a seat for the tennis player

### Where Freckles Come From and Why They Stay

A BEAUTIFUL face is a silent recommendation and an index to your state of happiness and health. Even the most peach-like skin proves to be a pleasing background for a dainty brown mole or "beauty-spot." But there are blemishes and blemishes.

What is usually spoken of as freckles are spots of yellowish-brown color. Especially after the skin has been exposed to the sun for a long while do freckles make their unhappy appearance. They are as unwelcome as weeds, and as stubborn as the mule Maud. The face, neck, and hands are molested most-

ly, for they are much exposed to the sun and are unprotected by clothes. Some people are much more liable than others to suffer these blemishes, and in some they disappear quite quickly, while in others they last a long time.

However, in most instances, freckles are the result of the action of the sun on certain cells of the skin, which causes these cells to produce coloring matter, or pigment, which remains there for a long time. Sometimes freckles do not appear to be caused by very hot sunshine or exposure, but just seem to come naturally, just as the color of the skin is either fair or dark, according to the tendency inherited by the individual.

No matter how the gorgeous illuminations of a toilet-articles counter may appeal to you, or how the delicate perfumes of ready-made toilet lotions and freckle-removers lure you, the best advice is to shun them.

### An Old Lamp Used by Rubber Gatherers in Brazilian Jungles

THE Brazilian rubber gatherer, far from civilization on the tributaries of the upper Amazon, is often compelled to use his ingenuity to improvise substitutes for the articles which he cannot obtain. This lamp was constructed out of an old gunpowder flask, cutting the handle and reflector from an empty kerosene can. The wick is made from a piece of gunny sack. With this crude device the native lights his path through the jungle when making his nightly rounds to collect the milk from the rubber trees he is tapping. When he desires a light for his hut, which is upon rare occasions, he uses the old powder flask lamp, burning it sparingly.

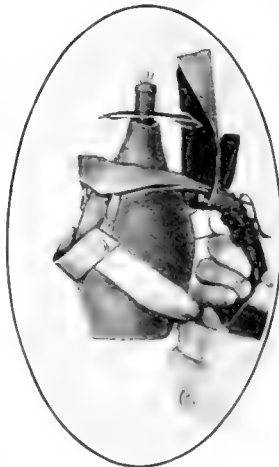

A lamp made from an old powder flask

# Piano and Phonograph Combined

**M**ANY attempts have been made to construct an instrument that would successfully reproduce at the same time phonograph and piano music. Edwin S. Votey of New Jersey has taken out patents on an instrument which he believes meets all requirements. His invention comprises a piano or player-piano with an opening in the wall of the casing for a phonograph or any record-controlled mechanism for the reproduction of the human voice, and a sound-blending chamber in the rear of the sounding-board into which the sounds from the phonograph as well as of the piano mingle for the purpose of producing harmonious effects.

The phonograph is mounted in the upper part of the casing of the piano and is provided with an opening in the front of the piano for the placing of records on the machine. For the sake of neatness of design and symmetry this opening is duplicated on the opposite side of the piano. Back of the sounding-board is an expansion chamber or sound-blending chamber into which the music from the phonograph is carried by means of a flexible sound-conduit leading from the phonograph to the sound-chamber.

The lower ends of the sound-chamber converge downward and at the lowermost extremity an outlet is provided in the shape of a horn attached to the front casing of the piano, with its opening closed by lattice work or a screen. The conduit, passage-way, sound-blend-

ing chamber and horn taken together constitute a sound-conducting passage.

In operation a record is placed upon the phonograph, which is wound through the doors. The perforated music-sheet is placed with the mechanism of the piano and the instruments are ready to play. The phonograph is started and with it the piano, both of them by hand in the usual manner, care being taken to start the piano so that it will commence playing as nearly as possible at a certain point with the phonograph. The music having begun, the musical time of the piano is adjusted by means of a tempo-lever to accord with the musical time of the phonograph. Thus the two instruments are made to play together in the same musical time.

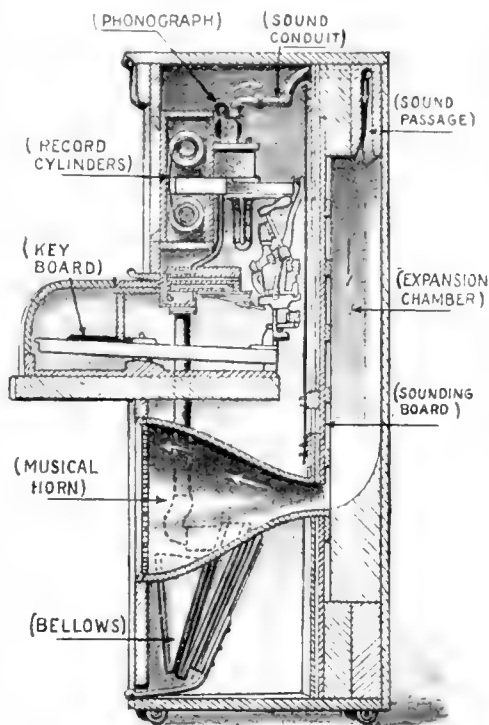

The piano and phonograph are made to play together in the same musical time

## Curious Set of Features Are New Markings on Mars

**D**R. PERCIVAL LOWELL announces from his Flagstaff Observatory that a curious set of features, secondary to the main canal network, have become apparent on Mars. Within some of the polygons made by the intersections of the larger canals a tiny dot has been descried, joined to a corner and to the sides of the polygon by lines so slender they usually appear as a string of minute beads. The effect is of a centrally-woven web, spun within the borders of the polygon, of a more minute order of tenuity than the polygon itself. These details are so minute as to suggest a new order of Martian markings.

### The World's Largest Ship's Register Chiseled in Rock

**D**OUBTLESS "Lloyd's" is larger in the sense that it contains a longer list of names, but on the score of sheer size there is nothing else in the world to compare with the great "Ship's Register" of the port of Muscat.

Muscat is the capital of the Sultanate of the same name which occupies the southeastern corner of the Arabian Peninsula, and from its position at the mouth of the Persian Gulf it has become a port of call for all vessels serving the Turkish and Persian coasts, as well as one of the stations for the British navy. In the early seventies the Yankee skipper of an East India-Boston clipper, which had been driven into Muscat by a storm, whiled away the day or two that his crew was busied with repairs by painting the name of his ship, the "Mary Wade," on the black basaltic rock of the hillside above the bay.

The striking effect of the large white letters against the dark background induced other skippers to follow suit, and it is said that very few indeed of the craft that have visited Muscat in the last three decades have failed to "leave their cards" on the hillside. The most imposing records are those left by the British men-of-war, the jackies of which have vied with each other in trying to make the name of their ship the most conspicuous. The names of the "Red-

breast" and "Odin," which may be clearly seen in the photograph, are fifteen to twenty feet high in the original, and painted on carefully chiseled and smoothed stretches of rock. To an American the most interesting name is that of the "Isla de Luzon," painted in 1898 before that Spanish gunboat was captured by Dewey.

### Firing with Heavy Artillery at an Enemy You Can't See

**A**RTILLERY fire is not unlike quarreling by telegraph, according to Dr. George W. Crile, an American physician who visited the fighting front and observed the behavior of men in the act of making war. "In contrast to the vis-a-vis trench fighting with rifles and hand grenades and dynamite," says he, ("A Mechanistic View of War and Peace," The Macmillan Company), "artillery fire is more severe only when concentrated, and the convulsive effect of bursting shells brings other forms of injury. . . . The process is in a measure comparable to 'caisson disease' or 'bends' in workmen laboring under atmospheric pressure in tunnels under water. . . . The artillery man rarely sees the object of his fire; he has no personal contact with the enemy, but suddenly finds himself under a scorching fire, from a source which he cannot ascertain, from an enemy he cannot see. It is like quarreling by telegraph."

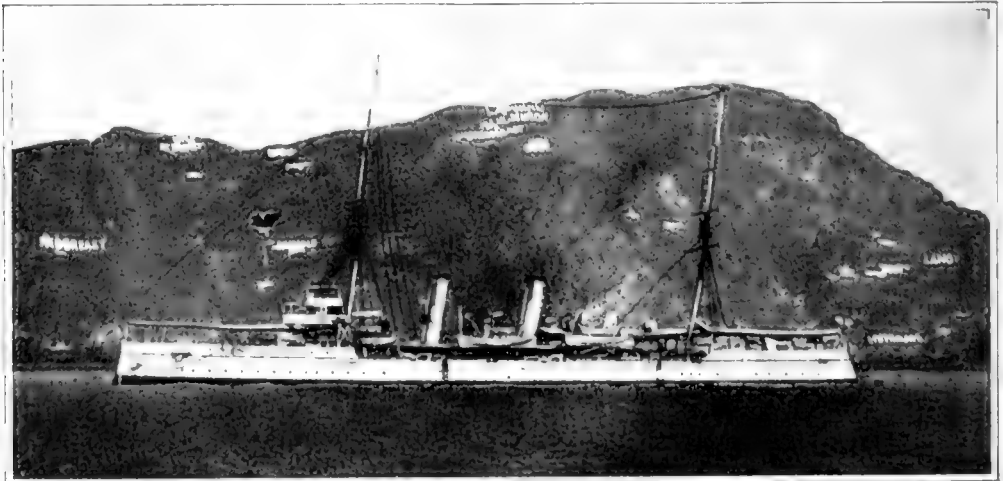

Few craft visiting Muscat have failed to "leave their cards" on the hillside. The names of the "Red-Breast" and "Odin" are from fifteen to twenty feet high chiseled in rock

# The Submarine Blockade Runner

## A U-Boat to Carry Contraband Cargos

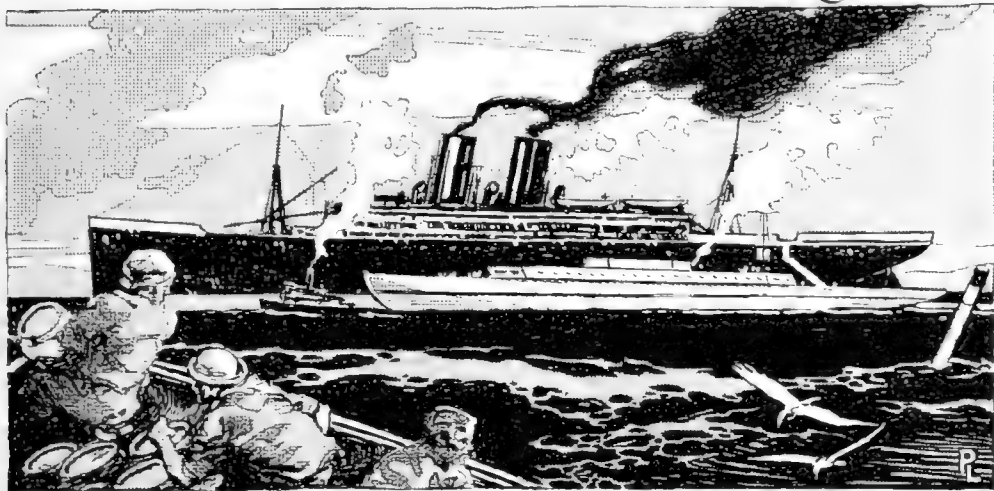

**T**HANKS to the control of the North Sea by the British fleet, the entire manufacturing world has been forced to realize its dependence upon Germany for many materials. Some coal-tar drugs, dyes, and the like are worth anywhere from ten dollars to one hundred dollars an ounce; others cannot be obtained at any price. Germany, on the other hand, is beginning to feel the pinch of want. Meat is so scarce that it may soon be worth dollars a pound. If it were only possible to run the blockade in and out of Germany, what a fortune could be made by selling coal-tar products in the United States and food in Germany!

Now it is obvious that the only successful way of escaping the blockade is to travel either above or below the vigilant British cruisers—travel in the air, or travel below the surface of the water. To carry even a few hundred pounds of freight through the air is out of the question. Neither the dirigible airship nor the aeroplane could ever make much money as a blockade runner, simply because of its limited carrying capacity.

But what of the submarine? What are the possibilities of carrying fairly large and extremely valuable cargoes in under-sea craft?

At least one submarine designer apparently believes in the possibility. He is Simon Lake, one of the foremost authorities on submarine boat construction in this country. A few months ago, he patented a cargo-carrying submarine, the inspiration of which was probably given by the present war situation; for he says in his patent, "I provide an exceedingly novel construction of submarine or submergible boat particularly designed for carrying cargoes of various descriptions, and which will be found of inestimable advantage in supplying blockaded countries with food-stuffs or war materials during hostilities, and which may be readily submerged, when upon the high seas, in the event of interception by an enemy's fleet."

The construction of this cargo-carrying submarine of Mr. Lake's is utterly different from that of the familiar destroyer of battleships. Its external appearance is perhaps not so widely at variance with the accepted type, but its interior arrangements are in every way remarkable. The vessel which we picture would be at least 350 feet, and possibly 400 feet long, and would be able to carry about 5,000 tons of cargo.

To carry 5,000 tons at the surface, the vessel must be extraordinarily buoyant.



To attain that buoyancy is the chief problem of the designer of a cargo-carrying submarine. Let us see how Mr. Lake has solved this problem.

Study the accompanying drawings and you will notice that Mr. Lake's blockade runner consists of an outer hull and an inner hull. The outer hull resembles that of the ordinary surface vessel in all essentials. The inner hull is

submerged. When the vessel is to rise, the sea water is pumped out. When the vessel is submerged, the cargo-carrying tanks are entirely surrounded by water.

The inner hull is pressure-resisting, the outer hull, non-pressure-resisting. The water-tight cargo tanks are obviously set in compartments which may be regarded as water-ballast compartments. These are filled during submergence and

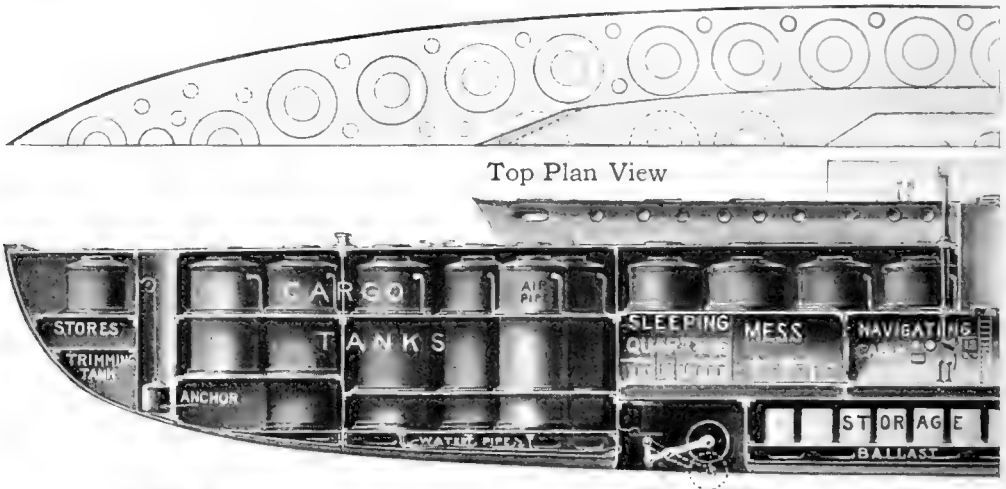

## A Submarine Blockade Runner Which Could

Newspapers have had much to say of a mysterious German cargo-carrying submarine which will run the British blockade and which will bring to New York coal-tar dyes and chemicals, some of which are worth as much as \$100 an ounce. The difficulty of obtaining suitable engines has not been considered in these accounts. But the designing of a boat, apart from the provision of adequate motive power, is not hopelessly difficult. Simon Lake, one of the foremost American inventors and builders of submarines, has patented the design here shown. The cargo is stowed away in air-tight and water-

a long cylinder divided into compartments to provide sleeping quarters, a mess room, a navigating cabin, a galley, an engine room and the like. The cylindrical inner hull is air-tight and water-tight.

The cargo is disposed in vertical tanks between the outer and inner hulls. The cargo tanks are air-tight and water-tight and are filled from the top. Air-tight and water-tight closures are provided.

The spaces formed between the outer hull and the inner hull are to be filled with sea water when the vessel is to be

are emptied when desired by means of compressed air which is blown from bottles located in the lower part of the hold. As the water is ejected, the space will be replaced by air of such pressure as to equalize the external pressure and thus prevent the collapse of the outer hull. Indeed water is freely used so that the outer non-resisting hull may stand up.

Above the superstructure will be noticed a glass coaming. This is about six feet high and serves to prevent the wash of the waves from obscuring the periscope.

Another feature of the cargo-carrying boat is the provision of wheels which enable the craft to travel on the bed of the ocean, rivers and the like. Mr. Lake was the first to use what may be called "automobile submarines." Indeed his first venture in the submarine field was the *Argonaut*, which ran on the bottom of Chesapeake Bay. The wheels are of great service in following a dredged

rather in oil engines suitable for submarine purposes, lies somewhere in the neighborhood of two hundred horse-power per cylinder. The Germans are now building submarine torpedo boats about two hundred and twenty feet long, propelled by twin-screw engines aggregating two thousand, four hundred horse-power and giving a surface speed of seventeen knots. A submarine some-

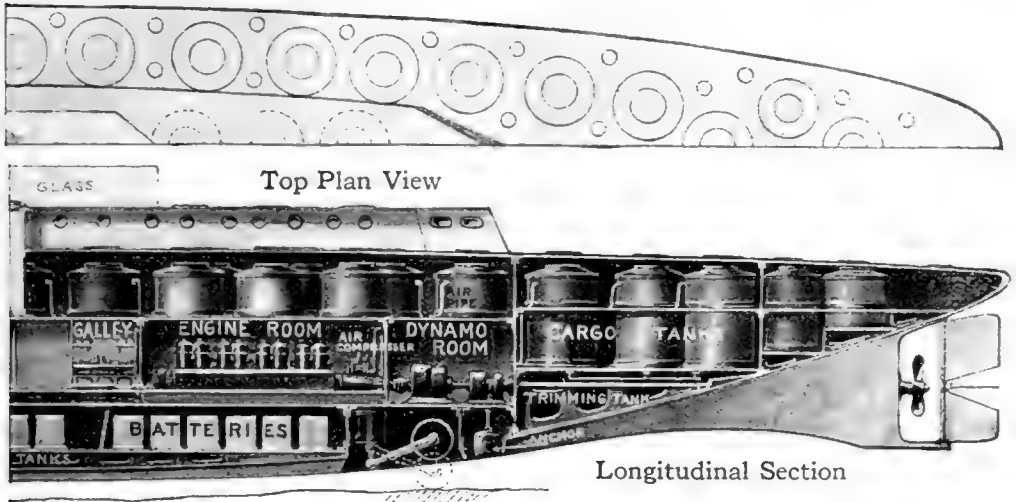

### Carry \$1,000,000 Worth of Chemicals

tight cylindrical tanks. The quarters for the crew, the engine room, etc., are contained in a water-tight cylindrical inner hull. When the vessel is to submerge, the entire space between the inner and outer hulls is flooded with sea water; when the vessel is to travel on the surface, the water is pumped out. The submarine boat has wheels, so that it can travel along the bottom of a dredged channel—a method of propulsion which Mr. Lake has successfully employed. This huge submarine would be about 350 to 400 feet long. It would be not a submarine but a submersible ship

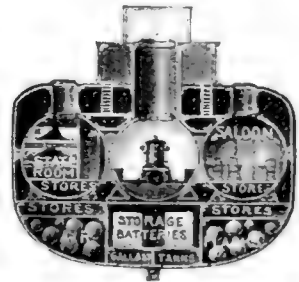

channel. In some experiments which Mr. Lake performed for the Russian Government at Libau, some years ago, he was able to pick his way out of a harbor much more easily than competitors of his, simply by running along the bottom of a dredged channel.

There is no inherent difficulty in building a cargo-carrying submarine, even though it be four hundred feet long. But there is great difficulty in obtaining engines which will drive it.

The practical limit of size as yet attained in big submarine engines, or

what bigger, requiring three thousand, six hundred horse-power to develop a surface speed that will enable her to be of any practical use will need three engines with six cylinders each. Now, for a vessel four hundred feet long a very powerful set of propelling machines will be required. Oil engines are out of the question. Steam engines must be employed. And the use of steam engines means the solving of the very difficult problem of insulating the generating apparatus so that the crew will not be parboiled.

The adaptable stepladder in two of many positions in which it may be placed. On the left, the bracing legs are folded up on a bench and the stepped legs reach to the floor. On the right, the position is exactly reversed, with stepped legs folded up and bracing legs in extended position

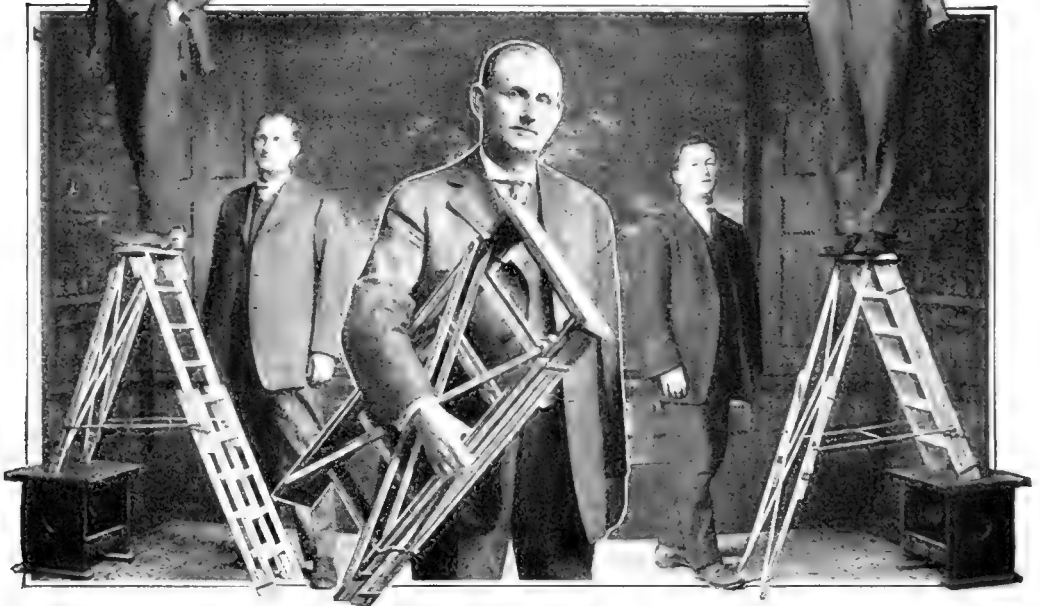

#### A Stepladder with an Ambition to Adapt Itself

THE common or garden variety of stepladder has been in use for so many years that most inventors have forgotten about the possibility of improvements. An Oregonian who had some tasks of varying height to accomplish, hit upon an ingenious idea in adaptable stepladders and secured a patent. In appearance, when folded, the ladder could almost be classed as "pocket variety." It is not much longer than a man's arm, yet when it is unhinged it attains a height of about five feet. The most ingenious feature of its construction is the provision of foreshortened legs. The legs which are fitted with steps are placed upon a stool or a chair of ordinary height. The bracing legs reach to the floor. This performance is reversible: i. e., the bracing legs can be folded up and placed upon a chair with the stepped legs resting on the floor. Also, both sections can be opened, when the ladder becomes an ordinary stepladder. In its extended position it

looks fragile and too light to sustain a heavy weight, but it can hold up a live weight of two hundred pounds and more in any one of the several positions in which it may be placed. As a serviceable, portable ladder around the home it meets every requirement.

#### Pulverized-Coal Burners on Our Modern Steamships

THE combustion of a "spray" of coal-dust blown into the fire-box by a blast of air is very nearly perfect, eliminating smoke, cinders, and firing tools. A high temperature is obtained, actually melting the ash which runs down the walls of the fire-box, and which is easily disposed of. The use of this device, so similar to oil-burners where a jet of oil is blown in the boiler with a stream of air or steam, is past the experimental stage. More heat is obtained from a ton of coal in this way; and rather poor coal can be used. It is probable, if tests succeed, that coal-dust burners may displace oil-burners on many steamships.

Moving Guns with an Electric Battery Crane-Truck

UNCLE SAM may be a bit slow in getting his guns into action, but when it comes to moving them he is right on the job. The photograph shows a two-ton battery crane-truck used at the Naval Gun Factory at Washington for the transportation of guns of all sizes, except the big fellows who are given a moving apparatus of their own. The crane-truck eliminates all danger of fire, and safety and speed are its two best qualities. It can be operated wherever there is room for it to glide about, and it is just as useful on the street as it is indoors.

The battery which serves as the propelling power for the truck operates the crane. The driving and crane control handles are within convenient reach of the driver and he operates them simultaneously. When the truck has completed a day's task of lifting and transporting guns it is used as a trackless locomotive for hauling trailers or gun carriages. Uncle Sam takes particular care to have his shop vehicles electrically operated, to avoid all possible danger of fire.

Surviving Horse-Car Lines in the United States

HORSE-CARS still are operated in at least two American cities, New York and Middletown, Ohio. Tiny, low, short, and mounted on a single truck, these cars were built to haul about twenty persons. To-day they often are crowded with two to three times that number and the horses are sorely pressed to draw the load.

When the Middletown horse-car line went into bankruptcy several years ago a junk dealer bought it for four hundred dollars. His profits have been more than three hundred per cent a year, and if he were to pull up his tracks and sell them and his equipment, he could realize many times his original investment.

Recently an order has been given by the public Service Commission of New York that the horse-cars must go. The reason for the demise of these municipal curios is that the picturesque equipment of 1860 can not meet the traffic demands of the 1916 public.

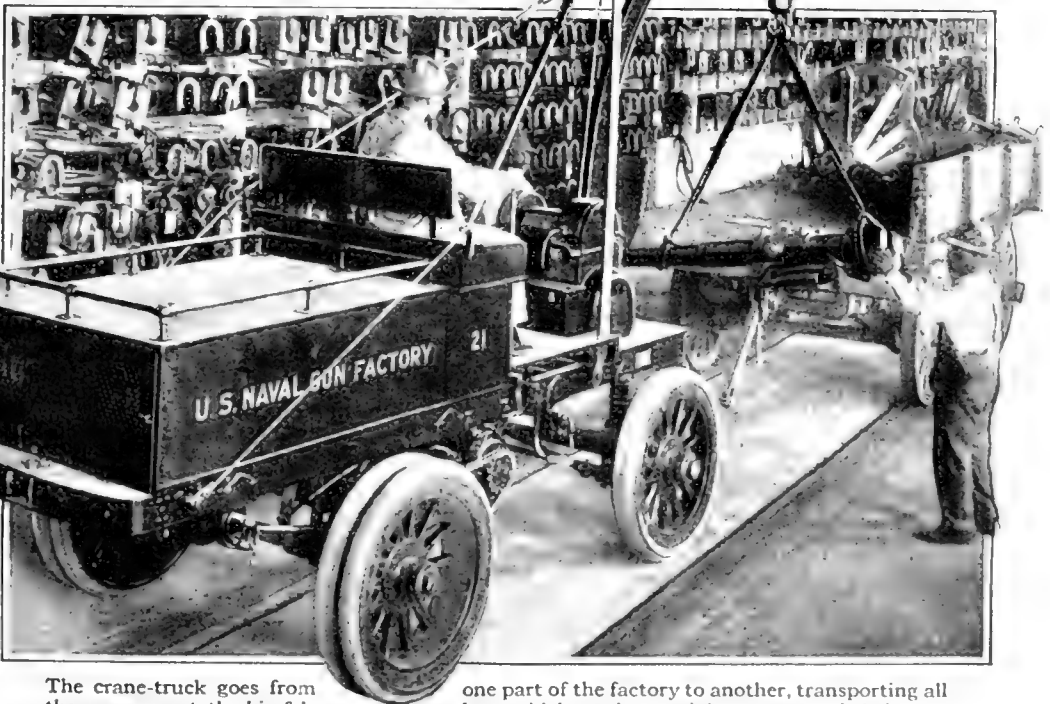

The crane-truck goes from the guns except the big fel-

one part of the factory to another, transporting all lows which need a special apparatus of their own

# Why Some Girls Don't Leave Home

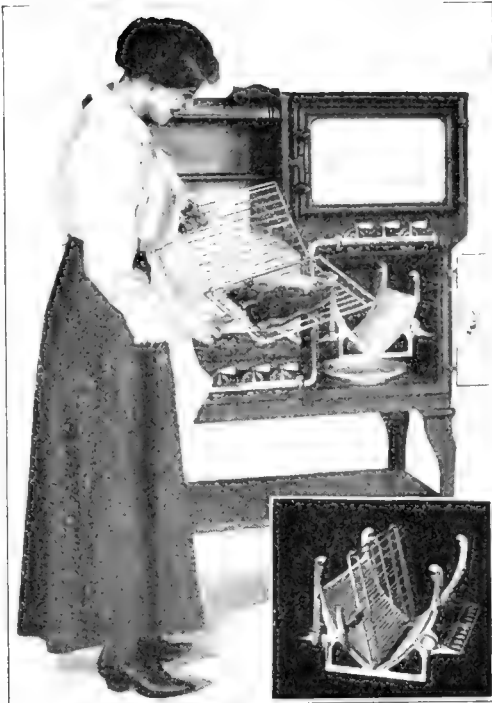

Broiling a steak without finger-burning is easy with this grid. Meat juice flows down the sides into a pan; the grid is then reversed and the meat is turned over by pressing a releasing lever at the left side



The weight of the beer bottles holds them in the carrying frame



A lamp-shade having umbrella ribs. The light can be dimmed by closing the lamp-shade



The small rotating tables which are similar to the "Lazy Betty," can be telescoped into the large dining table



Wine can be kept air-tight with this little bottle pump

# From Kitchen Drudge to Household Mechanic

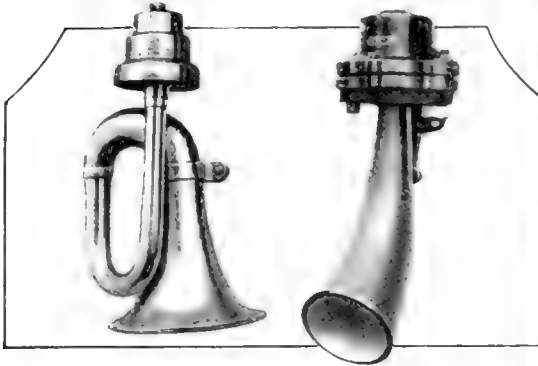

Electrical automobile horns are now taking the place of doorbells. Sound is produced by the vibrations of a delicate membrane

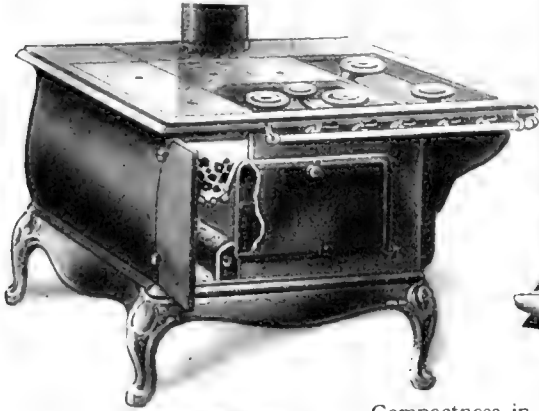

Compactness in the form of a gas and coal combined



A mop and brush combined. In circle the mop in use is seen. In oval is shown the method of renewing the worn felt. To change the mop to a brush all that is necessary to do is to release the lever



Bones crushed between the rollers make good chicken food



A kitchen utility tool for any number of tasks. It grinds meat and coffee, slices vegetables and freezes cream





This big dump of culm coal is on fire, although there are no visible signs of it. A trench is being cut across the pile to restrict the fire to its present field and prevent it from spreading

### Coal-Dust "Mountains" are Now Repositories of Wealth

**I**N the anthracite mining region of Pennsylvania there are real ranges of hills, almost mountains, of pure coal. These are the piles of culm or coal-dust screenings, which, under former methods of mining, were thrown out as so much waste. There are millions of tons of this culm, and modern furnaces are now using it. Culm is not only screened and burned as by-coal, a "dust," but is also pressed into briquettes. Modern coal-dust burning locomotives are using it as pulverized fuel. As such it is of permanent value.

The photograph shows a large culm dump near Scranton, Pennsylvania, which has caught afire. Once a fire gains good headway it is extremely difficult to extinguish; it burrows down into the very heart of the pile and then works its way along laterally. A few years ago this culm pile would have been allowed to burn itself out as a worthless property. Now it is being saved, as

shown in the picture, by cutting a trench across the pile to check the progress of the fire. Although the photograph gives no visible evidence of a fire, proximity to the radiating heat of the pile would prove to the onlooker that the interior is a veritable inferno.

### A Damaged Lock-Gate Repaired by Its Own Water

**W**ATER swirling out of the locks at Sault Ste. Marie damaged one of the gates so badly that the canal engineers despaired; but the trouble was singularly righted by allowing water to rush in again. A ship had passed out of the canal, and the lock was allowed to drain, but one of the gates was closed too soon, was caught in the rushing water, and buffeted so roughly that the top was sprung more than a foot out of plumb. Several unsuccessful attempts were made to repair the sagging gate by means of jacks and turntables. Meanwhile, a long line of ships from the North and South was impatiently gathering,



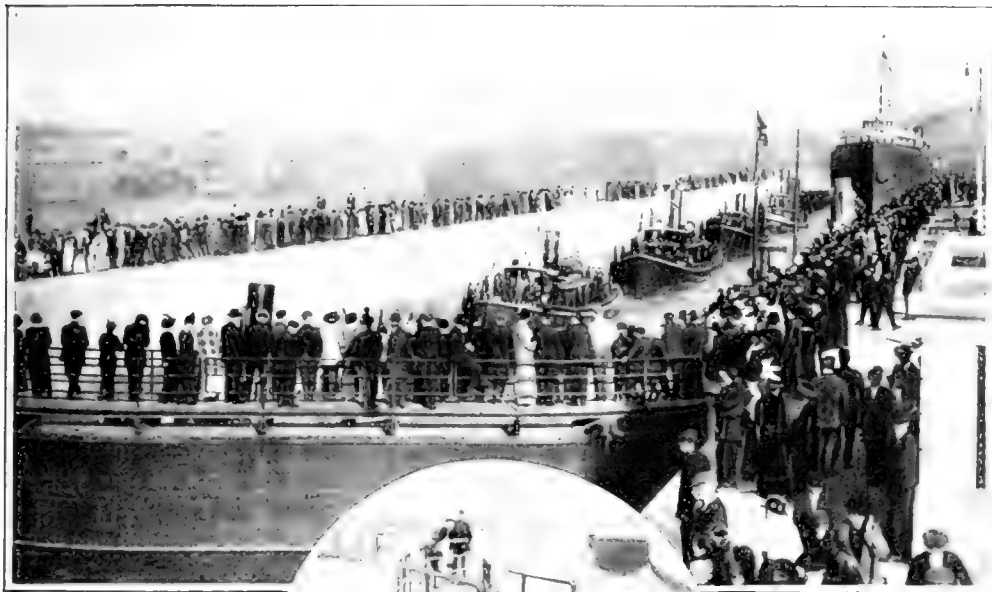

Above, the opening of the new "Number Three" lock at Sault Ste. Marie, Michigan. This was the lock which was damaged and which later repaired itself with the aid of water

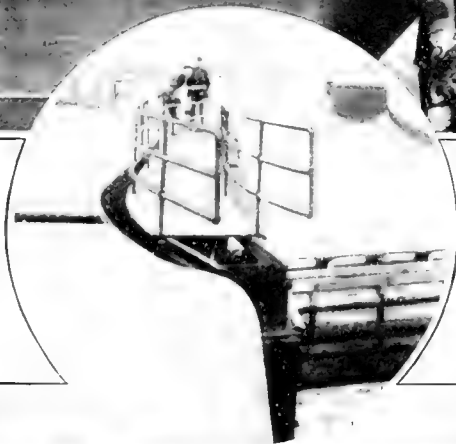

In the circle, a view of the spring lock-gate when it was forced a foot out of its correct position. Below, the damaged lock and the flow of water which moved it into place

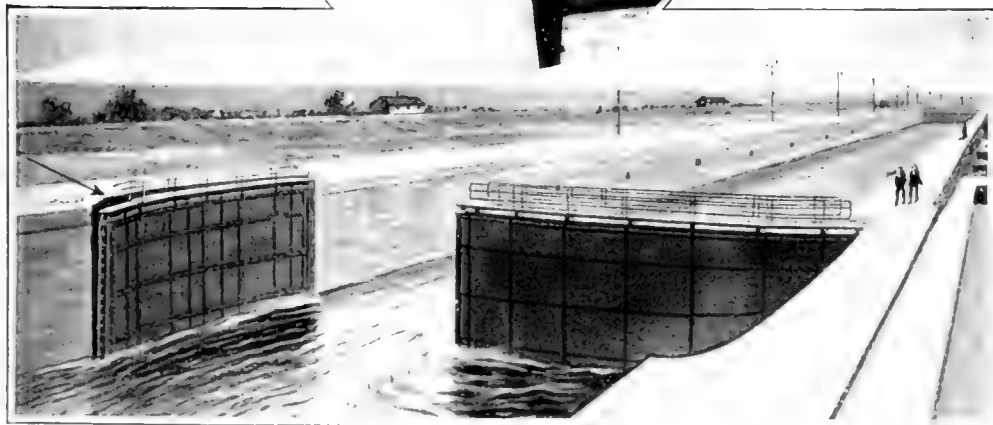

some of them with perishable cargos promised on early delivery.

One of the engineers hit upon the ingenious if somewhat hazardous scheme of injecting enough water into the lock to force the gate back into place. Accordingly, the valves were turned on, water flowed in, and the gate was slowly pushed back into its old position.

While this makeshift repair was satisfactory for the time being, when navigation closed this fall, the gate was entirely repaired.

This is the new "Number three" lock, which was put in commission about a year ago to cope with the increasing freight and passenger traffic between Lake Superior and the lower lakes.

# Taking the Smoke Out of the Smokiest City

## How Pittsburgh Has Solved Its Most Irksome Problem

The public now knows that smoke means a waste of fuel; that a waste of fuel is a waste of money, and that a waste of money is bad business management. The Bureau of Mines says that the best smoke preventer known to science today is a conscientious and careful fireman, provided he is supplied with necessary aids in the form of proper equipment. The smoke is expressed in terms of the Ringlemann chart

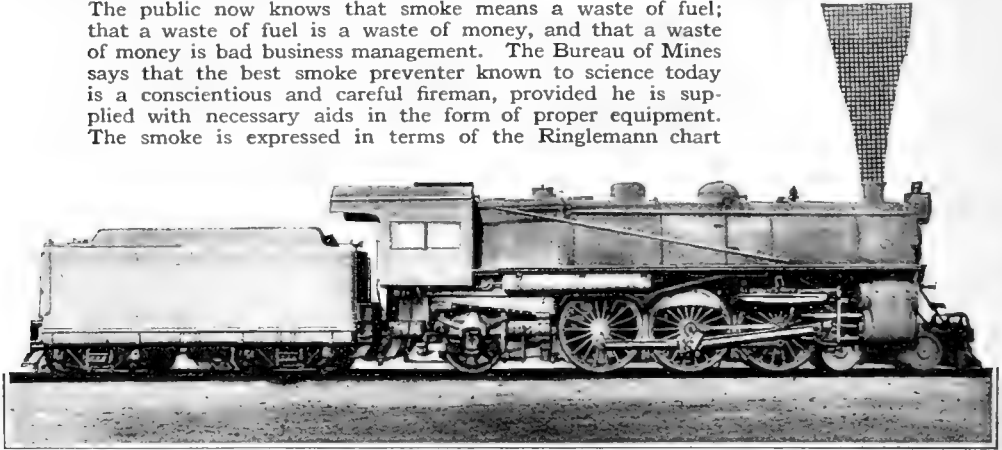

**T**O all intents and purposes, Pittsburgh has solved its smoke problem. Although it is having a hard time living down the time-worn nickname of "the Smoky City," the fact remains that as a result of the efforts of a municipal Bureau of Smoke Regulation, the "production and emission of smoke" in Pittsburgh has been abated fully seventy-five per cent within the past three years. And that in spite of the fact that the business activity and the coal consumption have greatly increased during that time.

No other city has been confronted with a smoke problem of such magnitude or has encountered so many difficulties in solving it. The three rivers, the deep valleys, the frequency of high humidity and low wind velocity, with resultant fogs, were handicaps to be overcome. The extent of the mill district, the great number of stacks in restricted areas, the immense quantity of smoke-producing fuels consumed, the characteristics of the high volatile coal natural to the district and the variety of boiler and metallurgical furnaces, were in part responsible for the dense smoke that used to cover the city like a

ball, sometimes making it necessary to use artificial light in midday.

Experts have calculated that smoke causes more than a half billion dollars damage each year to lives and property in the United States. Investigators of the Mellon Institute of Industrial Research, University of Pittsburgh, discovered that Pittsburgh's annual loss, due to the smoke nuisance, was at least ten million dollars. The agitation for smoke abatement crystallized into a great civic movement, in which all the industries of the city were urged to join. On March 4, 1913, the city council passed several ordinances relating to the regulation of production and emission of smoke and enlarging the scope of the Bureau of Smoke Regulation, organized some time before. The smoke limits were changed from eight minutes in one hour for all stacks, to one minute in any period of eight for locomotives and steamboats, and two minutes in any period of fifteen for all stationary stacks.

The Bureau also extended its inspections and watched closely for violations, appealing to the industrial and business concerns to assist as a matter of

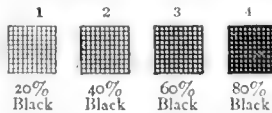

Ringlemann smoke chart with which the density of smoke is estimated

civic pride and for the general good. All of this was done without legal process or application in any way to the courts, although the Bureau was empowered to act against violators. The next year, twenty thousand "cleaning-up" cards were distributed with good effect. They contained the Ringlemann scale for smoke density adopted by the United States Government Bureau of Mines—inch squares checked off in one hundred spaces by light, dark, dense and black lines, representing densities of twenty, forty, sixty and eighty per cent—the third, or sixty per cent, being the legal maximum. The Pittsburgh Chamber of Commerce endorsed the work of the Bureau.

Conferences with railroad operating officials and manufacturers enabled the Bureau to suggest smoke abatement appliances especially fitted for each plant. The widest publicity was given the campaign by local newspapers and there were few stacks in the city that did not have their smoke output closely watched. Improvements had to be licensed by the Bureau, so that only practical appliances were permitted. Hundreds of concerns subsequently reported to the Bureau that the smoke abatement crusade had benefited them by helping to reduce their coal consumption and lessening operating costs.

The beneficial results of the smoke abatement propaganda have been widespread. Fully ninety-nine per cent of the locomotives in Pittsburgh yards are now complying with the law,

the number involved being eleven hundred and ninety daily. Before the campaign, only one per cent complied with the law.

Even to strangers in the city, the smoke abatement is very noticeable in Pittsburgh. The atmosphere is practically free from soot particles in the downtown section in particular. Fogs are dissipated by the middle of the day and frequently by the middle of the morning, whereas formerly the city was in a pall for at least a day, and sometimes longer. The Pittsburgh Weather Bureau local office announced that the periods of "dense smoke" last year were less than one half those of 1913, despite the fact that at least two and a half times as much coal was consumed. The Bureau of Smoke Regulation has calculated that the annual saving to the people of Pittsburgh, through the reduction in the quantity of smoke cannot be estimated at less than two million five hundred thousand dollars.

The proper way to read smoke densities from the Ringlemann chart is as follows: The chart is placed in line with the top of a stack a sufficient distance from the eyes so that the lines are not visible (about ten feet) and the smoke emitting from the stack is then compared with the different scales on the chart. This enables every factory manager and fireman to be his own smoke inspector and determine at all times if the smoke ordinance is being violated. In Cincinnati any smoke of greater density than the sixty per cent scale violates the ordinance.

The small particles of carbon which escape in the form of smoke are only a small part of the loss in the heating value of coal, for the loss due to the escape of combustible gases is ten or more times the carbon loss. The smoke escaping from the engine is Pittsburgh's legal maximum



### Eradication of Weeds Will Prevent Hay-Fever

AN authority on the subject states that from the standpoint of the number of patients affected hay-fever ranks among the first of the non-fatal diseases. According to him goldenrod is only responsible for a small percentage of cases, but the common ragweed, with its insignificant green flowers, is directly responsible for a majority of cases.

Besides the ragweed, of which two main varieties, the wormwood and the giant, are the most important, there are ten other plants indigenous to the Southern States, the pollens of which produce hay-fever. They all have the same characteristics: they are wind-pollinated; very numerous; the flowers are inconspicuous, with no bright color or scent because insects are not to be attracted, and the pollen is formed in great quantities. The development, duration, and conclusion of hay-fever are synchronous with the pollinating period of the ragweeds, and any elevation under six thousand feet may produce the weeds and the disease to susceptible persons. It would appear that there is a wide difference in the degree of susceptibility of different individuals to the pollen. An attack would develop, therefore, only when the exposure overcomes the resistance of the subject and only to this extent.

It has been asserted that the pollen, under the influence of the nasal secretion, germinates and sends out its germ tubes, thus producing the irritation. This germination takes place only in the presence of sugar, which is absent in the nasal secretion, and is inhibited by sodium chloride, which is present. The process of germination usually takes about two hours, while the local reaction of hay-fever may take place in a few minutes. The majority of hay-fever patients present no unusual abnormal intranasal condition except during the attack, and operations for nasal obstruction, unless indicated for other reasons, have been seldom successful in their intended results, and are rarely advisable. Any of the various treatments for hay-fever have not met with conspicuous success, and the sure means will be in the eradication of the weeds causing the disease.

### Protecting Jewelry Store Windows With a Burglar-Proof Curtain

THE thief, brick in hand, awaits his opportunity. When the policeman on beat passes out of sight he slinks down the quiet avenue and takes up a position in front of a jewelry store with an expensive and elaborate window display. Reposing in the right-hand corner of the window is a tray of diamonds. This the thief decides to steal.

Choosing a section of the window where the glass will make the least noise in falling, the thief draws back his right arm and the brick crashes through the window. With lightning agility he thrusts his hand through the broken pane, and then, startled and utterly dismayed, as quickly withdraws it. Had he not done so a burglar-curtain of steel, released from the top of the window at the instant of contact of brick with glass, would have severed his arm at the wrist.

In other words, he was thwarted in his attempt to steal by a burglar-curtain designed to drop and cover the window the instant the glass is broken. In making his superficial examination he had failed to detect the minute strands or wires stretched across the window, several of which were severed when the glass was broken, setting into action a mechanism which released the curtain.

The wires, stretched tight and anchored at their lower end to a rigid frame and at their upper end to a latch, are arranged close enough so that an object thrown through the pane will sever one or more of them. When this occurs the latch is drawn downward, permitting the retaining rods to move in under forced pressure of their tension springs, which releases a ratchet engaging with a shaft round which the curtain is wound. The curtain falls due to gravity.

The device has been patented by Max Richter of Chicago, but he does not specify any particular kind of curtain, although he suggests that steel would be the most effective. A simple safety appliance prevents the curtain from accidentally falling when the window is being cleaned. It is wound up on the shaft in a "set" position by means of a sprocket wheel.

# The Burglar-Proof Store Window

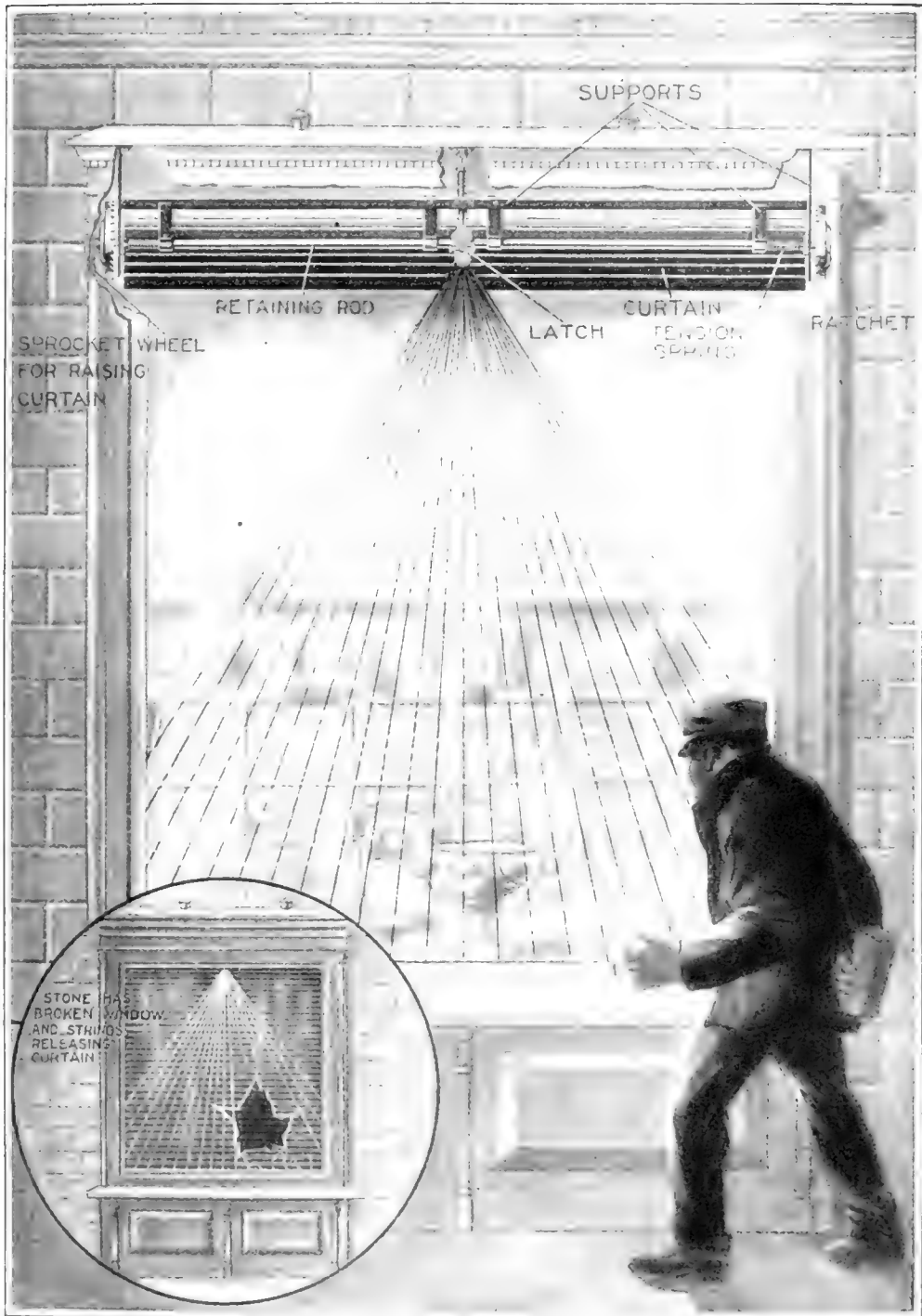

Let the burglar break the glass and at once a curtain of steel is released from the top of the window. It drops of its own weight the instant the glass is broken and one or more of the wires in back of the window are severed. The curtain is prevented from falling when the window is being cleaned by a simple safety appliance. A sprocket wheel winds up the curtain in a "set" position on the shaft. The breaking of one wire will drop the curtain

### Lowering a Bridge Without Blocking the Street Traffic

**T**HE task of lowering a bridge spanning the canal in Cincinnati without seriously blocking the enormous amount of traffic over the span, has presented an interesting task for the engineers in charge. A large number of car lines use the bridge, and there is much vehicle and foot traffic. To overcome this difficulty the bridge has been cut in two parts and while one half is being lowered and put in condition for use, the other portion remains with cars passing over it. Thus the traffic is only partially inconvenienced. This picture shows the elaborate mechanical equipment used in the work.

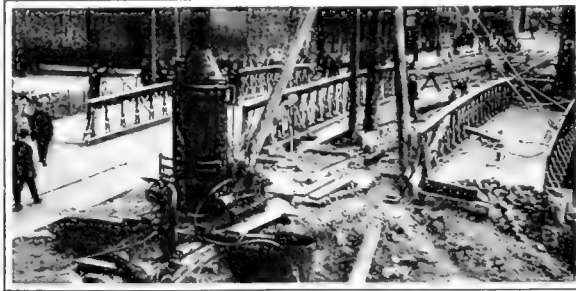

The bridge was cut in two parts and while one half was being repaired the other half was being used by cars

intended for light work have been introduced from time to time, but only recently has a man-sized portable grinder been a reality. A huge motor mounted on a three-wheeled truck supplies the driving energy to the abrasive wheel through flexible tubing. In operation, when the speed has been adjusted to suit the needs of the workman, he grasps the handles of the wheel on either side and brings it against the object to be ground at any angle or any pressure desired. Grinders of this type are intended for use in foundries or in factories where there is a great deal of heavy abrasive work to be done.

### How to Get Thin and Fool the Family While Doing It

**E**FFORTS at reduction at home are usually futile, because of the want of sympathy offered by the family, the difficulty in securing proper individual diet, the temptation provided by the daily sight of all kinds of food, and the urging of members of the family to be less strict than the physician directs.

Reduction treatment is easiest and vastly more successful in an institution or at a health resort, where definite diet can be prescribed and furnished, and where, in an atmosphere of routine and obedience, there is less temptation to transgress. There is every encouragement to persevere through the community of interest felt by every one and the force of numerous good examples of obedience daily before one's eyes.

Unless a settled determination and a conscientious effort exist in the mind, there is no use of attempting reduction of corpulence. Indulgence in alcoholic beverages, course dinners, extra suppers after theater, etc., defeat all measures that may be taken. These difficulties are oftenest encountered in people between the ages of thirty and forty.

### A Giant Grinder Which Goes to Its Work

**I**F you have an axe to grind, it is no longer necessary to bring the axe to the grinding wheel, for a portable grinding wheel of full-sized proportions has been brought into the grinding field. Numerous small grinding equipments



The grinder is a portable, man-sized one for heavy abrasive work in shops and factories

Why a Grasshopper Is Like a Telephone Lineman

EVERY boy and girl has seen a telephone or telegraph lineman climb a pole by means of iron spurs strapped to his shoes. The grasshopper's legs carry spurs which act on a similar principle, although the method is different. The grasshopper has neither the weight nor the strength to drive its spurs into the substance of the object or other surface on which it is climbing. But a twig or a grass blade under a microscope appears, as do the poles to the unaided eye, to be studded with holes and superficial rough places. The grasshopper's sharp spurs catch into some of these holes and uneven spots and thus enable it to climb.

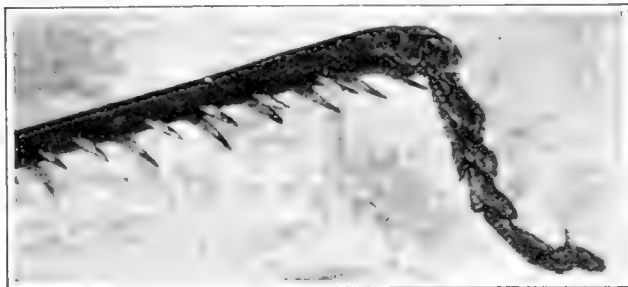

A grasshopper's leg, showing the sharp spurs which enable it to climb and which prevent it from slipping when jumping

By the aid of a small reading glass one can carefully watch grasshoppers in the act of climbing and discover that their method is much like that of the telephone man, with the exception already noted. Instead of making holes, they take advantage of holes already made. But they have still more frequent and serviceable use. This is to prevent the insect from slipping back when it makes its gigantic effort in jumping. Every one knows that it would be difficult to stand still on smooth ice and make a long jump forward. A rough surface facilitates the movement. The grasshopper is a more successful jumper than any boy can be, because it can leap many times its own length. It must therefore obtain a firm hold on the ground so as to prevent the loss of force by backward slipping. All its energy must be exerted in throwing its body forward. If a boy could jump like a grasshopper, comparing size with size, he could hurl himself forward at least four hundred feet. A grasshopper an inch in length finds it easy to jump a hundred times its length.

Hitting the Trail with a Wheel-Barrow and Determination

TRAMPING across the continent with the aid of all sorts of odd contrivances seems to be a favorite form of diversion for the athletically fit. The last team to "hit the trail" for New

York are two Bakersfield, California, mechanics, who are pushing their camp outfit ahead of them in a wheel-barrow. They intend to traverse the length of the Lincoln High-

way and expect to reach the end of their journey before the winter season makes camping too uncomfortable.

Their outfit weighs about one hundred pounds and includes a tent and necessities for road travel and life in the open. The whole load is packed on a specially constructed wheel-barrow which balances as perfectly as a pair of scales. It has a capacious sheet-metal body with handles about twice as long as those of the ordinary wheel-barrow. The handles are equipped with rubber grips. The wheel is of the bicycle type and it is set well back under the body. The vehicle is so arranged that the man pushing it bears none of the weight and can divert his whole strength to forcing it along the road.

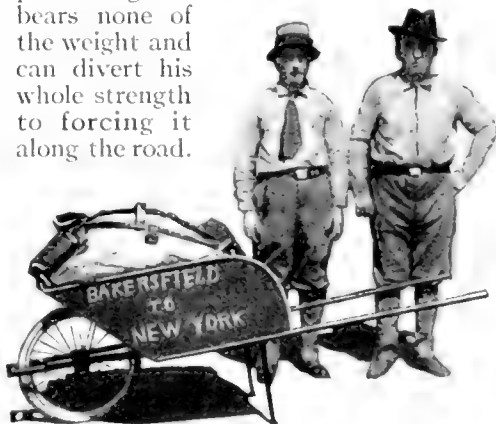

The determination is in the men; everything else is in the featherweight wheel-barrow



Automatic Flagmen to Warn Motor-Car Drivers

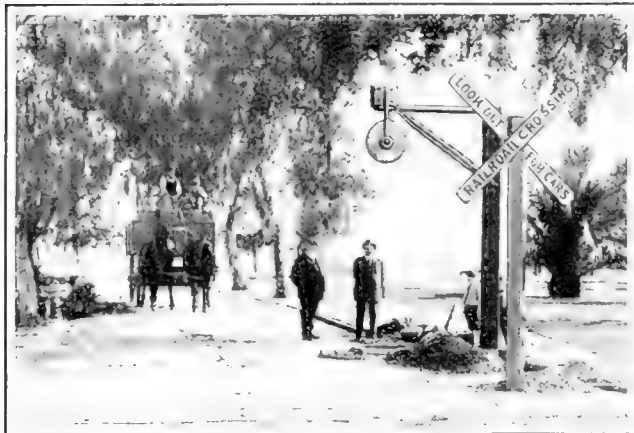

The automatic flagman at a crossing. At right, detail of four different installations

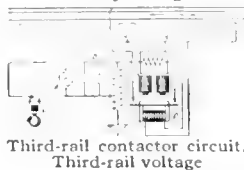
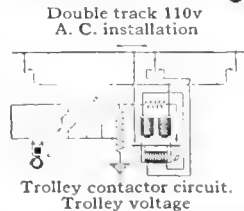
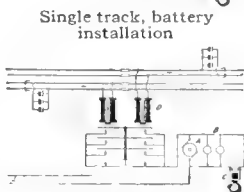
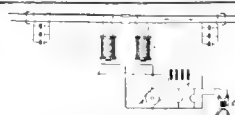

IN these days of automobiles and motor-cycles, something more than the old-fashioned "Stop, look and listen" sign is necessary at railroad crossings. Such signs are entirely too unobtrusive to attract the attention of a motor-car driver going at sixty miles an hour. At night they are practically worthless.

A striking experiment has resulted in the invention of the "automatic flagman." At the approach of a train it rings a loud gong, and waves a bright red disk by day and a red lamp by night. So sensitive is the human eye to red and to motion that such a warning can hardly escape notice.

The device consists of a

weather-proof case containing the operating mechanism and a signal disk upon which are mounted standard ruby-red switch lances with an incandescent lamp between. Energy is supplied by a small electric motor, which operates the mechanism that rings the gong and waves the disk.

The motor receives its energy from storage batteries, lighting circuits or trolley circuits, depending on the character of the installation. On steam roads the track is insulated and bonded for the desired distance away from the signal and is charged with current from a small battery. On entering this block the train completes the circuit and operates a relay, which connects the motor with the power circuit.

A Western Railroad's Clay Locomotives

WHEN a western railroad wanted to convey the information to the traveling public that its locomotives were of the newest and biggest design it called in Emory P. Seidel, the sculptor, and asked him to make models of them. Mr. Seidel searched some time for a suitable substance out of which to construct his models and finally decided upon a greasy composition from Italy which closely resembles clay. The models are five feet in height and represent three weeks' work on the part of the sculptor. The cost was five hundred dollars.

It took a sculptor three weeks to fashion these locomotives in a clay composition

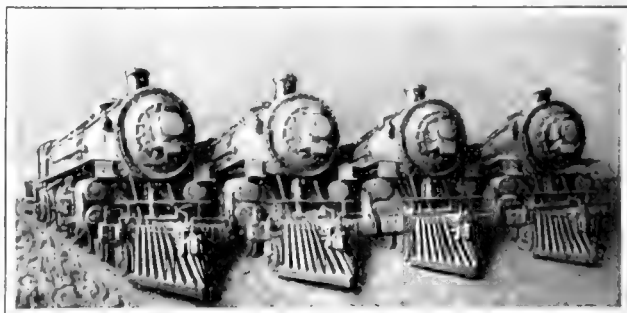

# Chinese Doctors and Their Ways

By Franz Otto Koch

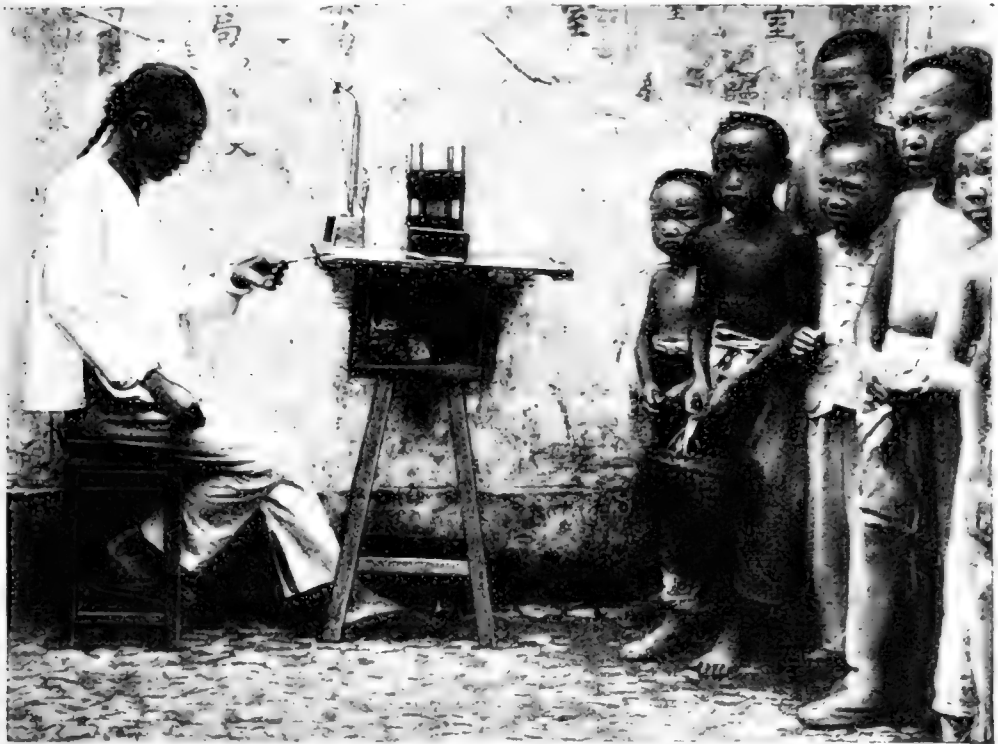

A Chinese street doctor examining hair from several youthful callers. The physician diagnoses a disease from a patient's hair and then proceeds to drive his needles

**T**HE native Chinese doctor is a curiosity. He passes no examination; he requires no qualifications; he may have failed in business and set up as a physician. In his new profession he requires little stock in trade, medical instruments being almost unknown.

Acupuncture, as it is called, is one of the nine branches recognized in medical science among the Chinese; it is of most ancient origin, having been in use from time immemorial. There are three hundred and thirty-seven body markings to be learned; every square inch on the human surface has its own name, and some relationship to the internal parts, purely imaginary, is assigned to it. The user is cautioned against wounding the arteries; hence he must know the position of the blood vessels. By close study of a manikin pierced with holes,

the Chinese physician learns where to drive his needles. Parts of the body are selected, which may be pierced without fatal results. Sometimes heat is applied to the outer end of the needle and this is called hot acupuncture, but the needle is never heated before insertion. In some cases the needle has been known to break in the body of the patient and has had to remain there until extracted by some skillful Western practitioner.

The needle used looks very much like a sewing-machine needle, but it is longer and coarser. Some of the Chinese doctors have needles two feet long, and are supposed, by ardent admirers, to be able to drive these instruments entirely through the patient's body. The great size of the needles is in reality intended to represent the greatness of the owner's skill and reputation. The needles used



whose father has been a doctor before him. Confidence in him knows no bounds should his grandfather have followed the same calling. This is not a mere fatuous belief in heredity, but is based on the supposed value of old prescription books passed on from grandfather to grandson.

At left, the attractive and decorative office of a prosperous Chinese physician in Peking. Below, drying medicinal herbs in a Shanghai courtyard. These are later made into medicine



are of eight forms, as follows: the arrow-head, blunt puncturing, spear-pointed, fusiform, round, capillary, long and thick. The point of insertion, the depth and the direction are all-important. The method is usually to drive the needle through the distended skin by a blow from a light mallet.

If he can get an old book of prescriptions from a retiring practitioner, so much the better for the Chinese doctor. He is now equipped to kill or cure, as chance or his ignorance may dictate. The doctor most entitled to confidence in the sight of his countrymen is the man

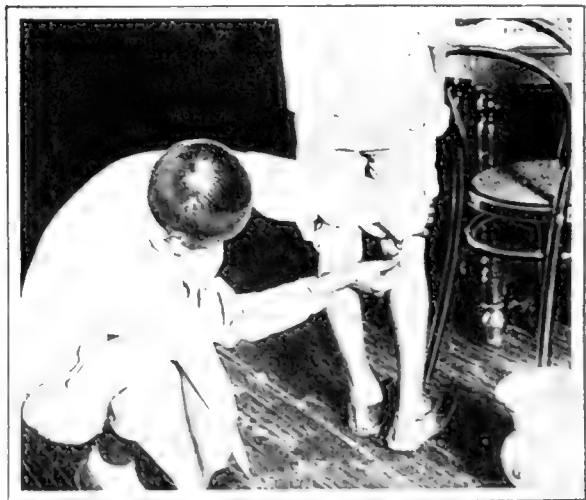

Acupuncture. The skin is punctured with a needle until in some spots it has as many holes as a sieve

Fees vary according to the physician's social class and that of his patients, and also according to the physician's place of residence. The enormous sum of perhaps fifteen American cents or half a dollar at the most may be charged for a visit, if the doctor comes in his sedan chair. Of this amount, a large proportion goes for the chair. Should the doctor belong to the humbler ranks and come on foot, his fee is proportionately less. He assumes a solemn air and an owl-like look as he peers out of the semi-darkness

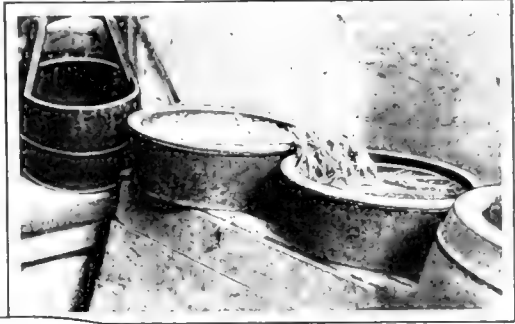

A choice assortment of medicinal roots soaking in a Chinese drug shop prior to their conversion into drugs



A Peking street dentist ready to do business. The monkey is his trade sign

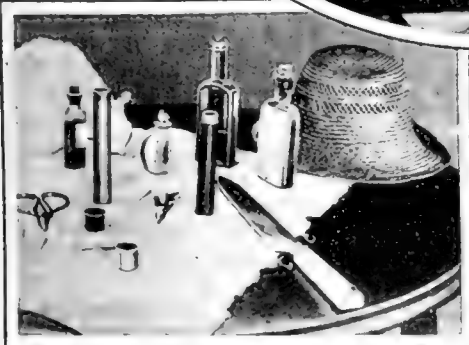

The Chief instruments of a Chinese doctor, including a pair of scissors, a large knife and a straw hat which signifies prosperity

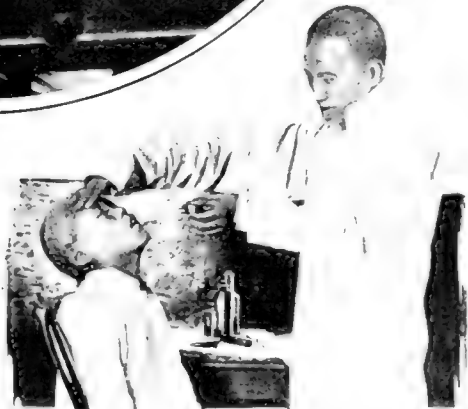

Doctoring the nose with a few drops of herb medicine on the end of a needle. Sometimes the needle is driven with a mallet

of a Chinese bedroom through great goggle-shaped glasses—two inches across and set in huge uncouth copper frames.

Most important in diagnosing a case, according to Chinese ideas, is the feeling of the different pulses of the human system. The pulse at each wrist is felt, and each is divided into three, which according to the light or heavy character of the pressure, indicates a different organ of the body. By thus feeling the pulses, the states of a dozen real or imaginary organs are determined. Having then learned by the pressure of these three at each pulse, the seat of the disease, a few questions may be asked, but these are considered scarcely necessary. A prescription, sometimes calling for the most horrible and nauseating compounds, is prepared in large doses; for the native believes that the larger the dose, the more likely is it to prove efficacious. In prescribing for natives, the foreign doctors have to give the strictest injunctions that the paper box in which the pills are contained is not to be swallowed.

Among Chinese medicines, besides some that are to be found in our Western *Materia Medica*, are snake skins, fossils, rhinoceros or hartshorn shavings, silk-worms, asbestos, moths, oyster shells, and other things. Almost anything disgusting is considered a good medicine. Apothecaries' shops abound where prescriptions are made up.

The manner in which the Chinese treat their physicians is characteristic. Should a speedy cure not result from the doctor's treatment, the patient calls in another. If he does not improve, he calls in a third. Thus the medical skill of the whole neighborhood may be drawn upon.

### Keeping Cool with a Fan Driven by a Hot-Air Engine

SUMMER and electric fans go well together, but where electricity is not to be had people have had to forego such pleasures. They will not be obliged to go without their summer breezes any more, however, for the little fan illustrated can be used any place where a connection can be made to gas or where alcohol can be purchased.

The fan is operated by a small hot-air engine in which all the rotating parts are carefully adjusted and balanced so that it runs smoothly and evenly, driving the blades at a speed sufficient to send forth a breeze that will lower the temperature on the hottest day.

The operation of the fan is interesting. The air in the lower end of the cylinder is heated by the lamp and expanding drives the piston upward, revolving the fan and creating a momentum. This cycle of operations continues, the fan gaining in speed with each revolution, and continuing to run as long as the fuel holds out. When gas is not to be had, denatured alcohol will serve as the fuel. In many cases the cost of operation is not more than one half cent an hour, and the fuel tank will hold sufficient fuel for twenty-four hours' running.

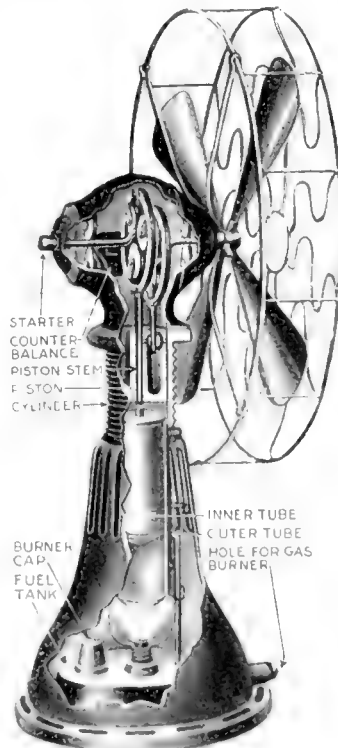

The fan is run by gas or denatured alcohol. It costs about one half cent an hour to operate it

### The Latest in Golf Clubs

APHILADELPHIAN has invented a "combination" golf club. A ratchet in the heel of the club makes the various angles possible. Give the ratchet a twist and you convert the club from a driver into a mid-iron, mashie, putter or niblick. The change is made in remarkably quick time, and it can be changed from a right- to a left-handed club without effort.

**A New Safety Razor with a Lamp Attachment**

**A**N Englishman, weary of bloodshed, has bethought him of a means of enlightening the gloomy and otherwise dangerous ritual of the shave. He has invented a miniature electric lamp provided with an adjustable clip and flexible cord which may be attached to the razor and light the path of the blade through the tough bristles of the human face.

With his lamp attachment one may plunge fearlessly into the blackest depths of a three days' growth of beard and emerge from the ordeal unscathed. The lamp is attached to a conventional type of razor by a simple clip. It travels with the blade or with the motion of the hand. By looking into the mirror the man shaving himself can determine just what progress he is making and whether or not he is going to come through the operation with his two ears intact.

The lamp clip can be attached to any one of the many makes of safety razors. The inventor is now busy on another lamp attachment for the old type of razor.

**How the Government Would Make Paper from New Woods**

**T**HAT satisfactory wood pulp can be made from a number of heretofore little known woods is evidenced by a government publication just issued, which contains seventy samples of paper manufactured by different processes, chiefly from woods practically unused for this purpose up to the present time.

**What Makes the Hair Suddenly Turn Gray?**

**A** PHENOMENON that has always aroused curiosity is the sudden turning gray of the hair under the influence of great emotion. Several historical instances are open to doubt, such as the case of Marie Antoinette, who is said to have become gray in the night before her execution, but there are several well authenticated cases vouched for by medical observers. One of these refers to a young soldier in the present war.

He was in a trench in the Argonne district which was blown up by a mine. He was projected into the air and then fell beneath a pile of debris. When he was extricated he was found to be deaf, and a few days later in an English hospital he noticed to his great surprise that there were tufts of white

hair on the left side of his head. The loss of color was complete from the roots to the ends of the hairs and the longest hairs were just as white as the shortest. There was not a brown hair amidst them. The gray hairs were solidly implanted and could be pulled out only by considerable force.

Subsequent investigation brought out the fact that the patient's left side of the head and face was most injured by the explosion and the fall of earth. He also suffered from an incessant twitching of the left eyelid. As his hair was whitened solely on the left side the physicians came to the conclusion that the injuries sustained were directly responsible, but they arrived at no definite conclusion. In fact, science has yet to find a cause for the sudden turning gray of the hair.



A miniature electric lamp is attached to the handle of the safety razor and helps to illuminate the gentle art of shaving

# Toying with High Tension Currents



At left, Prof. Thordarson and his helper and operating expert, Mr. Lindstrom

Below, using an umbrella to experiment with a three to six-inch spark from the safety-screen



**E**LECTRICAL science has brought forth so many startling discoveries in the last decade or two that even the average person is rather proof against being astonished at anything. Almost incredible accomplishments of an inventor's years of unremitting labors are often dismissed with the faint praise that electricity is only in its infancy. Like almost all other things, however, there are exhibitions of electric force that tickle the public fancy without conveying any idea of commercial worth. A good example of this is seen in the theatrical displays with high-frequency currents, the beholders little realizing that they are interesting applications of the same power employed in wireless telegraph transmission.

A remarkable electrical construction which has excited great interest in both the curious spectator and the far-seeing engineer is the 1,000 kilowatt, 1,000,000-volt, 60-cycle transformer, constructed by the well-known electrical instrument maker, Mr. C. H. Thordarson of Chicago. Requiring two years' time in construction, costing \$36,000 and entailing no end of thought and ingenuity, it was primarily made to demonstrate

certain theories on transformer construction and to investigate the behavior of electric conductors when charged with extremely high voltages.

Electric currents, when traveling at very high frequency, pass almost entirely upon the surface of the conductor. The resistance of such a circuit is therefore so high that unless a high voltage is operating no current at all will flow. Such conditions are met in stage apparatus. Ordinarily the operator can handle the conductors with impunity, the current merely passing through his outer skin or perhaps entirely in his clothing. The alternations may readily be a million per second or half that number of "cycles" per second. In the case of ordinary electric light and power circuits the most common frequency is 60 cycles per second, some, however, being as low as 25. In such cases the current flows quite like the direct sort, uniformly through the section of the conductor, whether it be wire or person, and a voltage as low as 1,000 is likely to be fatal. It is realized, therefore, that in the new Thordarson apparatus there is found for the first time the combination of the high voltage with ordinary



commercial frequencies. Some of the large manufacturing companies have, in recent years, constructed testing transformers for this same sort of circuit, but of only about half the voltage. Only those who have worked with very high voltages can realize the difficulties attending the construction and maintenance of such a special piece of apparatus.

While no one is as yet fully aware of the possibilities of this high power transformer, its electro-static effects are the most marvelous ever exhibited. Strangely enough, the spectators can actually toy with the powerful charges. Crowds of people at a time could walk through an "electrified" area 50 ft. square and 30 ft. in height, yet with no opportunity for dangerous contact. The general arrangements at the Panama-Pacific Exhibition for a demonstration were made in a building with canvas end containing the transformer and its controlling accessories, while under the large wire screen suspended by ropes from four electric light poles the visitors could pass and experience the peculiar and vivid sensations of high-voltage charges. Those wearing hat-pins, hair-pins, metal buttons, or carrying metal-handled canes or umbrellas, or even metal-bound purses with their coins, etc., were mysteriously "tickled" and provoked to amusing exclamations of surprise or fright. By holding the hat aloft one could draw sparks from the hat-band; by holding grounded metal conductors at arm's length 12-in. sparks could easily be drawn from the insulated rope safety-screen suspended 10 ft. below the charged screen, each discharge being accompanied by a diminutive thunder-clap. By merely standing on a box or some other insulating material and raising the hand, sparks three to six inches in length could readily be drawn and then passed along to persons standing on the ground. Vacuum tubes and incandescent lamp bulbs brought beneath the screen were continuously illuminated with the blue glow peculiar to such influence.

On dark nights the entire aerial

system was a mass of soft glowing "corona," the needle-points of discharge, or places of great concentration of electric spray, sizzling with the wonderful wizardry of electrostatics. On some occasions a corona a foot in diameter was observed surrounding some of the metal conductors. When a grounded water-jet spouted upward against a metal disk suspended from the charged screen the resulting luminous display of electric pyrotechnics was awe-inspiring; the length of the luminous discharges measured over 20 ft., while miniature thunderclaps reverberated to surprising distances. Some of these highly entertaining and amusing "stunts" are shown in several of the reproductions accompanying this article.



This is not a mop, which Prof. Thordarson is holding. Sparks are leaping to the top of a pole in his hand. From the safety-screen high-voltage charges and thunder-claps are coming



At left, view of aerial screen system and secondary apparatus for collecting charges. At right, public demonstrating screen suspended thirty feet above ground by four poles

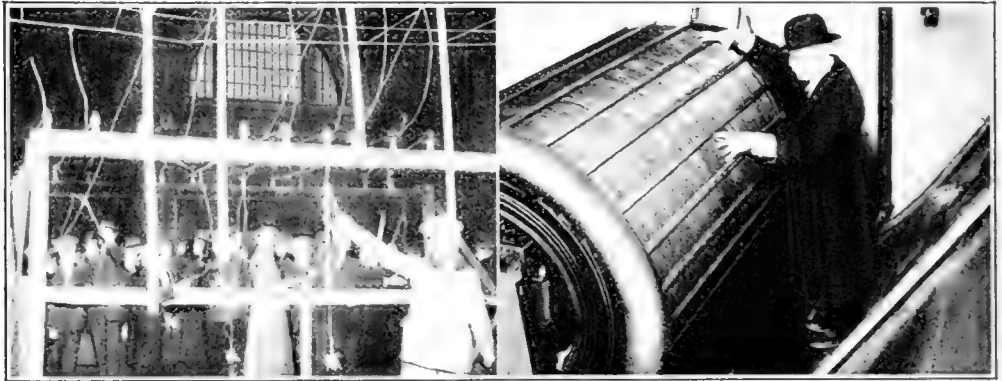

At left, spectators experimenting with apparatus. One boy is waving a vacuum tube. At right, Prof. Thordarson examining his one million-volt, sixty-cycle transformer

Engineers are of course interested in the details of construction of such a transformer, and some of the facts have been generously given by Mr. Thordarson himself and by his assistant and operating expert, Mr. A. S. Lindstrom. The laminated iron magnetic circuit is arranged on the "core" type, with both primary and secondary windings grouped upon one leg only. Horizontal members are 120 ins. in length, the vertical ones 40 ins., their section being 16 ins. by 16 ins. Primary winding consists of 122 coils of 44 turns each of copper ribbon, .020 in. by .281 in. in section, being the equivalent of a No. 12 round wire. These coils are placed  $\frac{1}{4}$  in. apart, pairs being connected in series, then the 61 groups connected in parallel for receiving the 2,200-volt supply. When assembled, the primary portion formed a cylinder 67 ins. long, 23 ins. inside diameter, 28 ins. outside diameter. As a protection from electrostatic surges

the junctions between the pairs were connected to a heavy copper bar that was thoroughly "grounded" to frame and earth. Over the primary coils was a specially prepared paper cylinder 92 ins. long, inside diameter 29½ ins., outside 41½ ins., therefore 6 ins. thick.

For the high voltage secondary winding 190 separate coils were used, each adapted for 5,300 volts, being all connected in series. Each coil consists of 212 turns of aluminum foil, .008 in. by .135 in., with three thicknesses of .006 in. paper between turns, and when finally assembled forming a tube 71 ins. long, 43 ins. inside diameter, and 51 ins. outside diameter. The construction of this secondary was of course the crucial part of the whole experiment, and the ingenuity that was brought out to cope with the different problems is of the greatest credit to the designer and builder. In general, the principle of construction adopted, that of breaking

up the winding into numerous separately insulated coils, was first utilized by Ritchie, the famous instrument maker, in Boston, as early as 1846, and then copied in the well-known Ruhmkorff induction coils, and now a common affair with all builders of transformers, but the application of the principle in this million-volt winding demanded a refinement of details not heretofore called for. Of course the whole structure required that its windings be protected from absorption of moisture.

### A Railroad Which Fights Its Own Fires

THE Transcontinental Railway of Canada is going to fight its own fires in the future. This is saying a great deal, since every other railroad in this country and Canada depends on available city firemen when railroad property catches fire, and when city firemen are not handy allows its property to burn up, helpless to save it because of lack of equipment.

When fires had destroyed valuable timber lines along its right of way and threatened to wipe out whole counties if something was not done to find an efficient means to combat it, the Trans-

continental Railway placed an order with the Canadian Government Railways' Shop at Moncton, New Brunswick, for a fire-fighting apparatus. The car illustrated herewith is the result, and it is now in operation.

The apparatus consists of a large water tank of more than ten thousand gallons capacity mounted on a flat car in order that it may be transferred to any point on the system where fire may be threatening. A steam-driven duplex fire pump which has a capacity of three hundred gallons a minute is mounted on the tank. The steam supply for operating the pump is taken from the car heater of the locomotive to which the car may be attached, and by setting the car heater regulator of the locomotive at a pressure of one hundred and twenty pounds per square inch, a water pressure of about one hundred pounds is obtained at the nozzle tip.

Before the apparatus was sent to the Transcontinental Railway the device was tested and found to be capable of throwing two one-inch streams of water a distance of about two hundred feet to either side of the track. This will enable the fire-fighting railroad company to extinguish all fires which occur within its right of way.



The fire-fighting apparatus is kept under steam so that it can be quickly transferred to any point on the railroad's system where fire may be threatening property worth millions

### Exit the Dinner-Bell; Enter the Flashing Mirror

FARMER'S wives in the great southwest, where ranches are miles instead of acres in extent, have a novel means of signaling the men in the field. Flags, bells and horns are used to announce dinner, but where the distance is too great these means fail, and the farmer's wife resorts to a mirror and the heliograph method.

"On a tour of inspection," writes a telephone man, "I happened to stop at a farmhouse for dinner. The woman who came to the door said that she would call her husband. Upon inquiring where he was she handed me a pair of binoculars and pointed down the valley. I looked and could see the big caterpillar pulling two headers. As it rounded the end of the cutting on its return trip the woman flashed a mirror into the eyes of the driver three times. As I watched I could see the machine come to a stop and presently I saw him coming up the road in his runabout car. He was working five miles away. The woman explained that she learned this heliograph method from the Indians." But suppose it's cloudy?



Calling the men to dinner by signaling with a mirror. But what if it rains?

### Why You Can See Two Sides of a Thing at the Same Time

IF you spin a quarter and watch it you will see both sides of the coin at the same time. This is explained by the fact that the senses of man retain impressions a little time. It is, indeed, the explanation of motion-pictures. Your vision persists and your perception of objects is continued after the object itself has disappeared. This allows you to see two parts of a thing—even such opposites as the front and back—simultaneously.

### War will Diminish the Stature and Vigor of the Human Race

THE most striking end effect of war is race deterioration," comments Dr. George W. Crile, a member of the American Ambulance who served during the first stages of the conflict abroad ("A Mechanistic View of War and Peace," The Macmillan Company).

"The effect of war on the race is seen in the effect of emigration on New England. In stature, in energy, and in enterprise, the New England farmer has deteriorated by losing so many of his fittest sons. It has been stated that Napoleon shortened the stature of the French by several inches. The human animal is not unlike other animals—no one breeds from scrub stock. This war will diminish the stature and vigor of the human race to the extent that the killed were larger and stronger than those who remained at home.

"The birthrate at the end of the war will be changed. It will be increased among the victors, decreased among the vanquished. In this respect man reacts like animals. Animals breed best amidst plenty, less when food and shelter are inadequate, and least of all when harassed in captivity."

### Plants on National Forest Ranges Which Kill Cattle

APPROXIMATELY eighty-five per cent of the losses of cattle on the National Forest ranges due to poisonous plants is caused by tall larkspur. Death camas, lupine, laurel, sneeze weed, and rubber weed are responsible for sheep losses from such cause, while loco weed is the principal poisonous plant affecting horses which graze about freely.

# A Gasoline-Electric Automobile

COMBINING the utility of both a gasoline and an electric automobile, a new dual-power passenger car recently put on the market by a western manufacturer, may be run by either gasoline or electricity, or both, thus retaining the great mileage ability of the gas car and at the same time the simplicity of the electric.

The power plant of this unique vehicle consists of a small gasoline motor and an electric-motor generator combined in one unit under a conventional hood forward of the dash, and a storage battery carried beneath the rear seats.

The speed is controlled by two levers mounted on the steering wheel, the power being transmitted through the propeller-shaft directly to the rear axle without clutch, gearset or levers, thus eliminating the trouble of their manipulation and at the same time giving a multiplicity of vehicle speeds. One lever operates the mechanism connecting the storage battery to the electric motor. The other starts the gasoline motor.

The vehicle is started as an electric by moving the electric control lever, which automatically connects the storage battery with the electric motor. As this lever is advanced, the speed of the vehicle is increased up to twenty miles an hour. If more speed is required, the gasoline lever is thrown in, connecting the gasoline motor with the electric motor, and starting the former without

stalling. As the gasoline lever is pushed still farther forward, it causes the car to be operated more by the gasoline power, until at a certain point the vehicle operates as a gasoline car, neither charging nor discharging the battery.

By a slight variation of the relative positions of the two levers, the battery may be either charged or discharged at will on any speed from ten miles an hour up to twenty-eight or thirty, the retardation of the electric lever causing the electric motor to act as an electric generator driven by the power of the gasoline motor. The current thus generated is used to charge the storage battery while the car is running.

The same effect may be secured at any speed above six miles an hour by braking through the electric motor when on level ground or when coasting down hills, this being accomplished by a retardation of the electric lever. A conventional brake pedal is provided for braking at speeds less than six miles an hour.

While the two power elements employed in the operation of this car are electricity and gasoline, one supplementing and augmenting the other, it may be run on gasoline power alone. There are no clutches to throw in, no gears to change and no waste of fuel in operating.

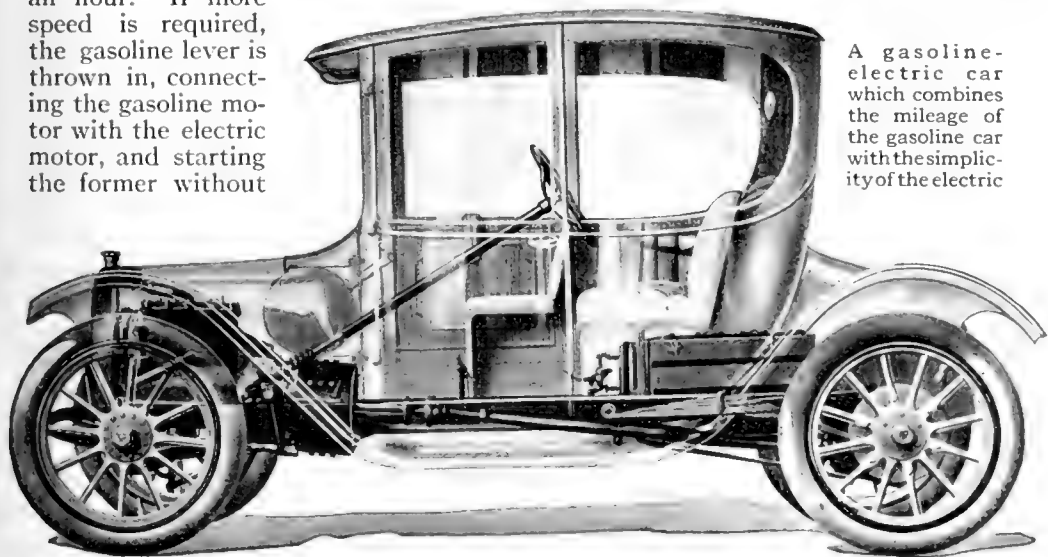

A gasoline-electric car which combines the mileage of the gasoline car with the simplicity of the electric

# What's the Good of a Hawk?

By Dr. R. W. Shufeldt

**O**F what use to man is this great army of hawks, harriers, and falcons we see or read about?

There was a time when these "hawks" and their kind were simply regarded as fit subjects for the brush and pen of the professional ornithologist; for the scalpel of the taxidermist, or a legitimate target for every gunner in the land that came across them in the open.

There is a splendid array of falcon-birds in our avifauna, the principal representatives being the Eagles, the Falcons, the Hawks, Kites and Harriers. Besides these, we have two species of Caracaras, as well as the famous Osprey or Fish Hawk. When one includes the latter, with the four different kinds of Eagles recognized by American ornithologists, there are in the United States, all told, no fewer than thirty-two species and twenty-one sub-species of such birds. None of these are as abundant as they were half a century or more ago, or even less time. Indeed, during the autumnal migration of birds southward in the early seventies, in the southern part of Fairfield County in Connecticut, I have seen as many as a thousand or more different kinds of hawks pass overhead in the course of a day; I very much doubt that one now could count, at the same time of the year, over a hundred.

The thoughtless farmer argues that hawks of every kind kill domestic poultry, and that he, for one, is for exterminating the entire lot of them. That thousands of chickens, ducks, young turkeys, tame pigeons, guinea-fowls and other denizens of the farmer's yard, have been, in time, destroyed by hawks, there can be no question; but even so, our investigation of such a serious matter should not rest upon a snap judgment, and lead us to condemn the entire tribe on that account.

In the first place, some hawks, as the Fish Hawk, live entirely upon fish, and never attack or destroy any kind of fowl or mammal, although it has the strength to kill a full-grown gobbler, were it to try to do so. The illustration here given is the reproduction of a photograph I made of a bird not quite full grown, which was in my possession for several days; I also made the other photographs for this article from living specimens of hawks in my keeping at different times. In so far as man's interests are concerned, the Fish Hawk or Osprey is entirely harmless.

All those hawks which we call Kites do not, as a rule, attack birds or quadrupeds of any kind, and *never* domestic poultry. They destroy, however, in the course of a year, millions of noxious insects and no end of vermin, which prey



Profile of the Osprey or Fish Hawk which lives entirely upon fish and other water food

upon the crops of the agriculturist. Still other species of hawks, as the Duck Hawk, prey entirely upon feathered game, and never come near the barnyard. Birds of that class do no more than we do ourselves—hunt ducks for food.

That a number of species of hawks do constantly prey upon both the old and young of various kind of domestic fowls, there is no question; moreover, they feed upon a large number of them in the course of a year. Still, no individual poultry-raiser or farmer loses a sufficient number of his fowls annually, through the attacks of hawks, either to impoverish him or so far embitter him as to cause him to be the enemy of every hawk of every species in the country. To follow such a policy is an extremely grave error; it would be like exterminating all snakes and owls for the reason that a few snakes are venomous, and the larger owls occasionally capture a domestic fowl. If we consider *all* the snakes and *all* the owls as a group, they save from damage and destruction farm products to the extent of many millions of dollars



The Broad-Wing Hawk which preys upon mice



A very young Sparrow Hawk in its fledgeling covering

Wolves of the Sea that Abound in Cuban Waters

**F**ACTS appear incontrovertibly that sharks, and big ones, abound in Cuban waters; that thousands of swimmers are never attacked; and that there are perfectly authentic instances of people being maimed or killed by them.

The Antillean shark is less dangerous than some Australian and South Pacific species. In clear water of fifteen or twenty feet depth he is timid. Near a boat anchored where the bottom can be seen from the surface, as in those waters it commonly can be at the depth named, the bather is safe. In deeper water there is risk. If there is blood in the water from a wounded man or fish, the swimmer's peril is great. Indifferent, lazy creatures, of a low order of intelligence, sharks are instantly frenzied by the presence of blood, and will attack anything that moves.

More than the sharks, the Barrera cruisers; fear, when inclined to a morning plunge, the picoua, a big and aggressive fellow with a protruding jaw fitted with long, sharp teeth. Lying motionless near the bottom in rocky retreats about the offshore reefs, he darts at his prey with remarkable swiftness. His sinister appearance has given him an evil reputation.



Full-grown Sparrow Hawk—one of the farmer's feathered friends

annually. The pity is that they are so constantly preyed-upon that they cannot accomplish results to be appreciated by us.



### A Handy Shoe Cabinet for the Whole Family

A GERMAN woman who claims to have gained her idea from practical experience has designed and patented a shoe closet which may appeal to the "cliff dwellers" of large cities or in fact to any persons with whom space in the home is at a premium. Fashions demand a staggering variety of footwear, and the favorite custom of stowing them neatly away under the bed or in the corner of a closet where they may gather dust is not only inefficient but

At right, the shoe cabinet for the family. This one is ornamental enough but it is not at all costly

Below, the cabinet reduced to a size for keeping the shoes of one person. The four shelves are each adjustable



Above, the interior arrangement of a neat and compact cabinet large enough for two persons

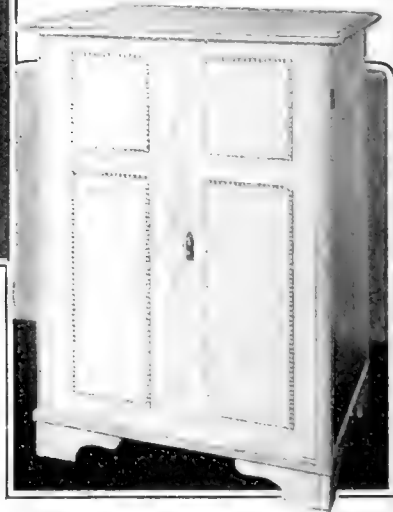

A cabinet of simple design for the family. It is polished and finished in white enamel

costly. Inefficient because the shoes wanted usually evade the eye of the wearer, and costly because shoes do not improve with dust.

The shoe cupboard designed by the German lady would in appearance if nothing else, improve almost any home. It is compact and shapely with nicely enamelled sides and swinging doors. Neat little racks are provided to hang the shoes on, and ventilators in the back wall insure proper cooling. The shoe wardrobe can be attached to the wall, placed upon the floor or upon a small stand or table, as convenient. If desired, it can be built in a clothes-closet which affords ample room for its construction, or it may be used as a storage closet in the maid's or children's room.





Above, a party enjoying a ride on the water with the new water-shoes. The paddles are used to steer and not to propel the shoes. At left, an Italian soldier operating his water-shoes and shooting his rifle

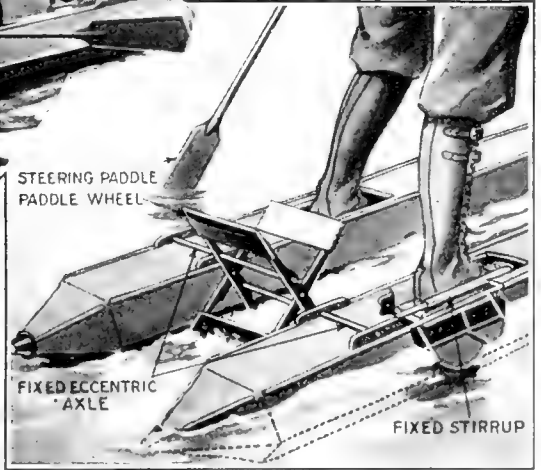

**"Canal Boats" Which Are Real Water-Shoes**

AN Italian electrician, Luigi Risso, of Genoa, has invented an ingenious form of water-shoe to which he gives the name "hydro ski." Compared with so-called water-shoes or skis already on the market it differs in the method of propulsion. Unlike forms introduced in the past, the present shoes, which are canvas pontoons, are provided with two sets of cross arms or axles to which paddles are fitted at their extremities.

It will be noted in the illustration that the paddle is fastened to one pontoon by means of an eccentric axle, and to the other pontoon by another eccentric

The mechanism of the water-shoe, showing the mounting of the paddle wheel on the pontoons

axle. These axles are not in alinement, so that by shifting the weight of the body from one shoe to the other alternately, the paddle wheel is turned at a fair rate of speed with very little effort. Steering is facilitated by the use of a double-blade paddle, which also enables the operator to maintain his balance.

# A Venetian Barge in Boston

A STRANGE looking craft made its appearance recently on the Charles River. It was an exact replica of the state barge of Venice used annually by the doge in the ceremony of the marriage of the Adriatic. It led the procession in the water festival at the exercises when the transfer from the old to the new Massachusetts Institute of Technology buildings in Cambridge was made.

The barge was named "Bucentaur" after the old Venetian name. The last Bucentaur or state barge was built in 1729 and was later destroyed by the French. The ancient ceremony was instituted after the victory of the Venetians over the Imperial Fleet in 1177, on the gift of a gold ring by Pope Alexander Third to the doge as a token of the city's dominion over the sea. It was celebrated annually on Ascension Day, the doge casting a consecrated ring into the sea from the Bucentaur or state barge. The Venetians called the ceremony an "espousal of the sea."

Technology's Bucentaur is one hundred feet long with a beam of eighteen feet and a draft of only fourteen inches. The galleys are ornamented with hand-carved figures

of wood in white and gold. At the bow is a massive figure, the symbol of the Institute of Technology. It is a woman in whose left hand is held a T-square and whose right hand holds aloft the torch of enlightenment.

On either side of the waist of the odd craft is an ornamental frieze more than fifty feet in length, made up of realistic-looking sea-horses, dolphins, mermaids and cupids, at play in the waves. On the main deck, at the stern, is a deckhouse with an arched roof supported by caryatids in groups of three. The flagstaff is erected at the forward end of this deckhouse. In all more than fifty figures were used in the ornamentation of the galley.

The barge was constructed on the suggestion of Professor Ralph Adams Cram. It has a twelve-horsepower gasoline engine to drive a propeller of twenty-four inches as an aid to the rowers. The whole superstructure is built upon what is practically a scow, the prow forming the overhang.

Over this overhang is the anchor well, where two mushroom anchors are placed, although invisible from the outside.

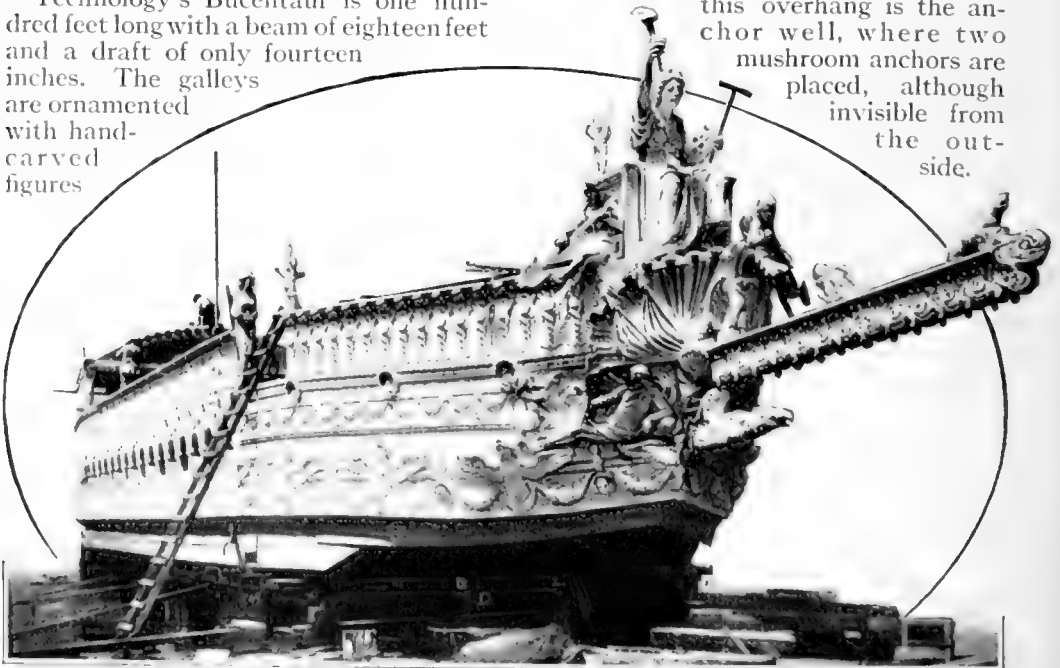

The Bucentaur led the procession in the water festival on the Charles River, when the transfer from the old to the new Massachusetts Institute of Technology buildings was made

# Uncle Sam's New Dam at Elephant Butte

At right, the storage dam at Elephant Butte, New Mexico, built by the United States Reclamation Service for the irrigation of thousands of acres of desert land. The dam was completed May 13th at an estimated cost of five million dollars. It stores eight hundred and fifty-six million gallons of water

In oval below, a general view of the dam looking East. The great body of water covers a complete range of low-lying hills and valleys several hundred feet deep. For the quantity of water stored it is said to be the greatest storage dam in the world. It holds enough water to cover the State of Connecticut to a depth of ten inches

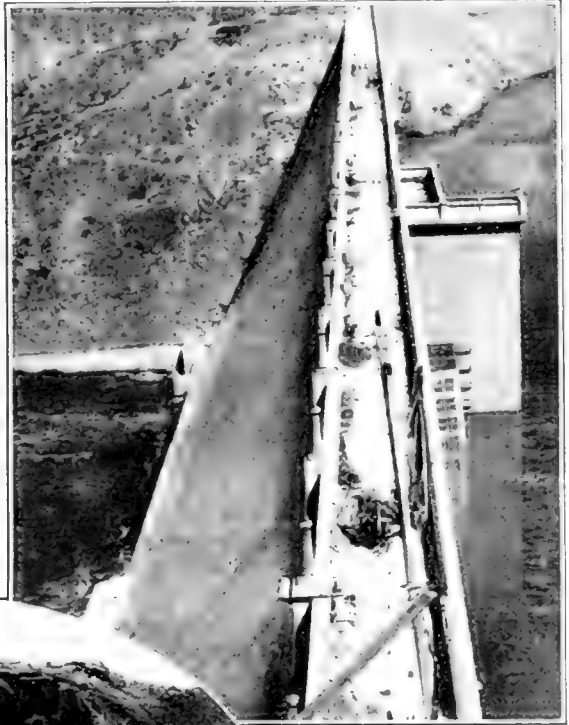

Below, a view of the retaining wall, which is three hundred and eighteen feet high and one thousand six hundred and seventy-four feet wide. The Washington Monument, if set at the outlet base of the dam, would rise above it only a bare two hundred feet

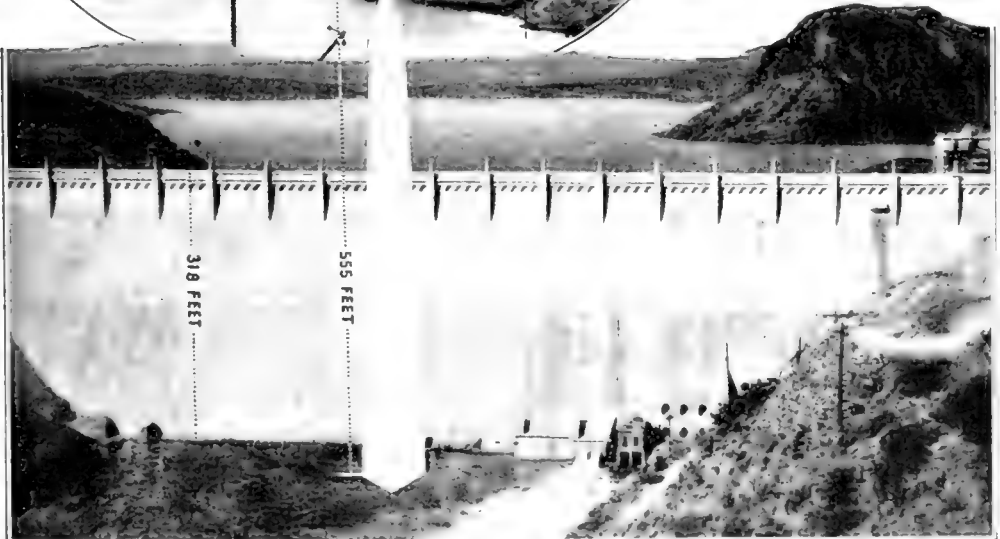

# Building Houses for Birds—A



At the first birdhouse building contest held in this country, in the State of Washington, seven hundred and eighty-two birdhouses were built by as many boys. During the one day

**I**N the Puget Sound country the severest winter of the last quarter century has been productive of a new constructive work, acquaintanceship with, and love for birds. For the first time in its history Washington took a real

interest in its songsters. People everywhere fed and watered the birds. Backyards were scraped free of snow so that the robins, thrushes, blackbirds, bluejays, snowbirds, and even the diminutive wren could hop around after

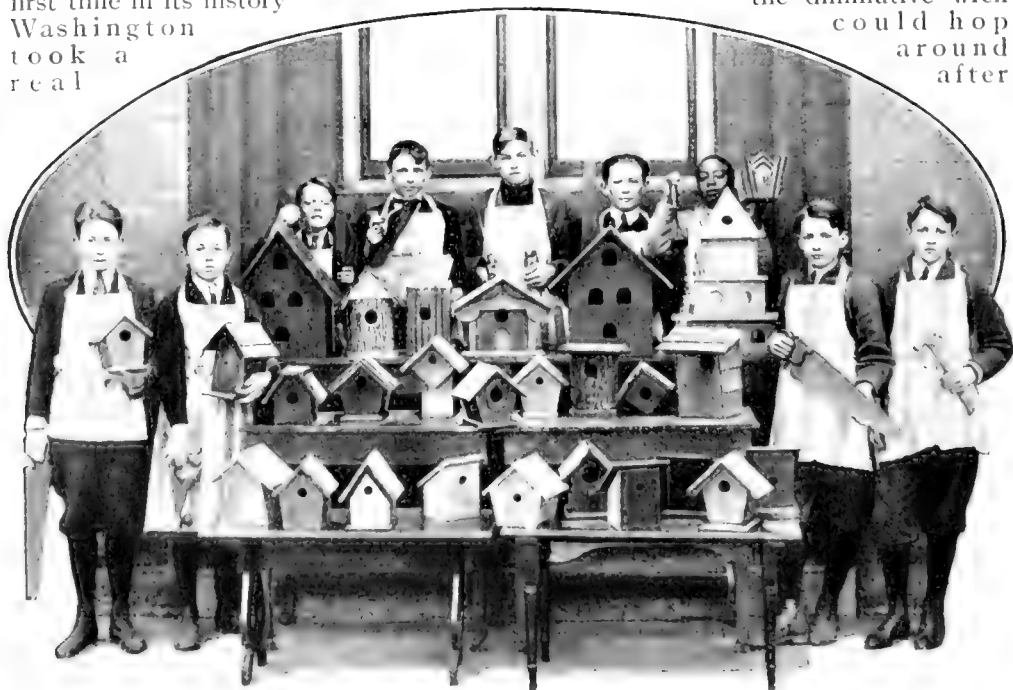

Twenty five different models of birdhouses built by boys from one school in the Washington contest. There are no two models of the same type and the designs are all original

# New Countrywide Movement



of its existence twelve hundred people paid to see the exhibit. From this auspicious beginning the movement assumed national proportions, spreading to all parts of the United States

rations. In addition to this the government maintained a "bird station," and the man in charge, Harry Dillaway, got the school children interested in a bird-house building contest, with the result that a birdhouse exhibit—the first of its kind ever held, attracted favorable attention from bird lovers all over the country.

When the exhibit was opened seven hundred and eighty-two future homes for birds greeted the visitors. The houses ranged all the way from the



The contest created a love for birds and stimulated a vital and permanent interest in the home workshop

humblest of cottages to the finest of mansions, and every one was in the prize-winning class. Many of the houses were ingeniously constructed, and not a few combined ideas of beauty and arrangement so novel as to warrant special mention.

To cover the incidental expenses of the exhibit an admission charge of ten cents for adults and five cents for children was made. During the one day of its existence there were twelve hundred paid admissions.

# Lubricating Your Automobile

By Waldemar Kaempffert

**A**N automobile engine is a heat engine. The gasoline is drawn into the cylinder in the form of vapor, which consists of about one part of gasoline to eighteen parts of air. The vapor, when it comes in contact with the electric spark, explodes, or, more properly stated, burns with flash-like rapidity. Anything that burns generates heat, and when heat is generated the surrounding medium expands. It is simply the expansion of the medium in the cylinder, produced by heat, that forces the piston down against the crankshaft and ultimately turns the wheels of the automobile.

The temperature at the instant of explosion is between 2000 and 3000°. If it were possible to convert the heat represented by that temperature into work, the automobile engine would be marvelously efficient. But we have not yet learned how to handle that heat. We must waste some of it by cooling systems to save our automobiles from destruction; otherwise the cylinders of a motor would be reduced to a mass of molten metal.

The lubrication of an automobile is a particularly difficult problem because the gasoline motor is so peculiar a heat engine. It is the object of lubrication to keep rubbing surfaces apart. But if the lubricant is a film of oil, often less than three one-thousandths of an inch thick, as in a gasoline engine, and the rubbing surfaces are very hot, how is it possible to attain that object? It seems almost incredible that lubrication is possible at all in an automobile, once the physical problem is stated.

A prominent automobile manufacturer has brought out a motor which has a speed, under certain conditions, of 3,400 revolutions a minute. An equally prominent refiner of oils has visualized these figures in a way that shows what is demanded of a lubricating oil. During a single minute, he points out, each cylinder passes through the four cycles of intake, compression, power and ex-

haust no less than 1700 times! More than 28 complete cycles in each cylinder, or a total of 171 complete cycles in all six cylinders within a single second! Every second the carbureter must furnish 171 complete charges of gas—the magnetto 171 individual sparks; and 171 times in a second the temperature at the instant of combustion reaches the almost inconceivable figure of nearly 3000° Fahrenheit. During each second the six pistons, each with a stroke of 4½ inches, travel a lineal distance of 255 feet, rubbing over a surface equivalent to a path 255 feet in length and 10⅓ inches in width—a total area of 216¾ square feet a second.

## *Friction and Lubrication*

The object of lubrication is, of course, to overcome friction, and friction in automobiles is due primarily to inequalities which are always found in the most highly polished surface. Even the smoothest piece of glass, when viewed under the microscope, is incredibly rough, and so are the apparently smooth walls of a cylinder and the surfaces of the piston rings and the piston. Press two apparently smooth pieces of metal together; then slide them in opposite directions; the two “seize”—interlock; the inequalities on the surface of the one intermesh with those of the other. Friction is produced, which means that heat is generated. Heat causes a metal to expand. The pressure on the outer surfaces does not permit of expansion outward. “Seizing” results. That is why it is the function of a lubricant to keep the surfaces apart.

Try to keep a red hot stove wet with dropping water, and you will realize the difficulty of lubricating a hot automobile motor. The greatest enemy of lubricating oil is heat. Hence of two oils that which loses little lubricating value under relatively high heat is the more suitable for automobile lubrication. Consider the temperature to which oil is subjected in a motor and you will under-



stand how important it is to consider the destructive effect of heat. When the spark ignites the fuel charge in the combustion-chamber the heat of the explosion is at least 2000° and even 3000°; the inner cylinder wall surfaces may be as hot as 350° and certainly no cooler than 180°; the piston heads may not be hotter than 300° but are more likely to be 1000°; the main shaft and crankpin-bearing oil varies in temperature from 140° to 250°; and the sump oil has a temperature of 90° to 150°.

*What Happens When Oil Is Heated*

Oil is a chemical compound of extraordinary complexity. The number of elements of which an oil is composed are few, but the number of ways in which these elements can be split up or combined is almost limitless. The properties of lubricating oil are dependent on the many chemical compounds present in the oil. Destroy that stability (the application of heat is the surest way of accomplishing this), and the oil ceases in part to be what it was before heating, both chemically and physically. The change which takes place in boiling an egg is not so great as that which takes place in an oil exposed to high temperatures.

After an oil has been used in a motor for a few hours it changes entirely in color. Yellow originally, it becomes blue, and, after the motor has run for several days, it turns black. What is more, a black deposit settles out—a deposit which consists of metal dust, rubbed off the friction surfaces, carbonaceous matter, and powder-like carbon. Of these the most destructive in their action—for oil is used over and over again in a motor car—are the metal dust and the carbon. They

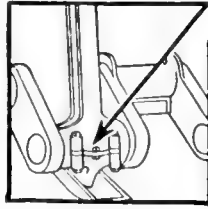

When the wrong oil is used the connecting-rod bearings wear away

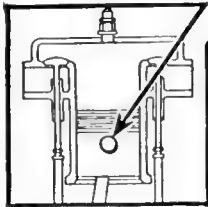

Worn wrist-pins result from bad lubrication

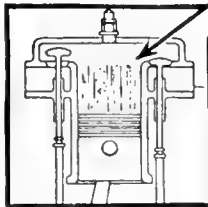

Cylinder walls are scored when lubrication is poor

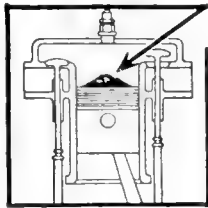

Carbon deposits are formed when the oil works past the piston rings

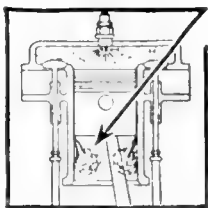

Too light an oil causes leakage of gases

cut like sand, and their effect on the bearing surfaces can therefore be imagined. Since this powder-like carbon is deposited as the result of heat, it is important that a heat-resisting oil be used. Unless an oil has the right physical and chemical properties it may do more harm than good in a motor. Oils are therefore tested in half a dozen different ways to ascertain their suitability for automobile lubrication. Some of these tests can be conducted only with scientific instruments; others can be made by anyone.

*The Flash Test and What It Means*

No oil can withstand the enormous temperature of 2000° and even 3000° to which it is subjected on the wall-surfaces of a motor during the brief moment of explosion when the piston is driven outward on its working stroke; fortunately the period of exposure is so short that only the outer layers, so to speak, of the oil are affected.

Above a certain temperature the vapors arising from an oil are inflammable, and the flash test consists simply in determining the temperature at which they will ignite without setting fire to the oil itself. A small test flame is brought quickly near the surface of the oil, contained in a little test cup, and as quickly removed after ignition of the vapors. The temperature is measured. If the flash point is much below 400° the oil is unsuitable for efficient lubrication, because it will obviously flash off the surfaces and also evaporate too quickly and will not last long.

A certain amount of gasoline always finds its way into the crankcase where it mixes with the lubricating oil. Since gaso-

line is highly inflammable it follows that both the flash and fire points of used oil are lowered below the normal flash temperature.

#### *The Fire Test*

The temperature at which an oil will ignite from its vapors and continue to burn, called the "fire test," is not of much use in testing fresh oils, but it does reveal much about an oil which has been used in an automobile. Heat tends to decompose an oil chemically into its lighter and heavier constituents, and the crankcase of some motors is always hot enough to affect an oil. The lighter constituents will ignite at a much lower temperature than the original lubricating oil. Hence, by applying the simple fire test, which consists in bringing a test flame quickly to the surface of the oil and allowing first the vapors to ignite and then the oil to catch fire from the vapors, it is possible to determine to what extent the oil resists heat. This applies chiefly to used oil. An oil that fails to meet the test satisfactorily will be used up very rapidly; it will be vaporized too easily.

#### *Viscosity or "Body"*

Of equal importance to the flash or fire test, is the determination of an oil's body—its viscosity. Water, which has very little body, is clearly less viscous than cane syrup. It is possible to measure viscosity by measuring the rate of a liquid's flow. Special instruments have been invented to measure that flow in a given number of seconds under a given head or pressure and at a given temperature. Viscosity is therefore usually expressed in seconds at a given temperature. If the oil is too light, has too little body, the rubbing surfaces will not be properly separated. Hence, an oil must be selected of such viscosity that it will reduce the fuel consumption for a given amount of power to a minimum and yet prevent the pistons and bearings from "seizing." That selection results in a compromise between the attainment of proper lubrication and of the utmost fuel economy. The point of compromise lies somewhere between 180 and 800 seconds, depending on the conditions under which the motor is operated and the particular design of the motor.

#### *The Carbon Residue Test*

Another test consists in measuring the carbon residue after complete distillation in a small flask. Every oil will leave a carbon residue, as it must, because oil always contains a certain amount of "fixed" carbon. The amount and character of the carbon left, however, is an indication of the grade of petroleum from which the lubricating oil was distilled and the care exercised in refining. All oils oxidize or polymerize when heated, forming sediment, the nature of which tells much about an oil. The heat of many explosions causes part of the film of the lubricating oil in the cylinder to flash off and to escape with the exhaust gases. A residue, commonly called carbon deposit, is left behind, however, consisting of carbon, solid hydro-carbons, etc. Oil must be continuously fed in to renew the thin film. It is evident that by testing an oil by heating it in a tube over a Bunsen flame, we are subjecting it to a condition something like that which it must meet in an automobile motor and that decomposition must always result whenever oil is called on to endure heat. The duration of the heating and the temperature, of course, affect the outcome of the experiments. Some manufacturers claim that they make "non-carbon" oils. An oil is composed of hydrogen and carbon in a chemical combination, just as water is a chemical combination of hydrogen and oxygen. It is just as absurd to speak of "non-carbon" oil as it is to speak of "non-oxygen" water.

#### *Tests for the Automobile Owner*

One of the easiest tests, which every automobile user can make for himself, is that which shows how the oil stands up under heat. A small quantity of the oil is heated over a Bunsen burner in a test tube until yellow vapors appear which will be in about fifteen minutes. If the oil turns black it is unsuitable for automobile lubrication; if it darkens but still remains clear, it is good.

Another test, easy to carry out, consists in shaking equal quantities of oil and water in a bottle for half an hour—the emulsion test. A poor oil (in part or wholly) mixes permanently with the

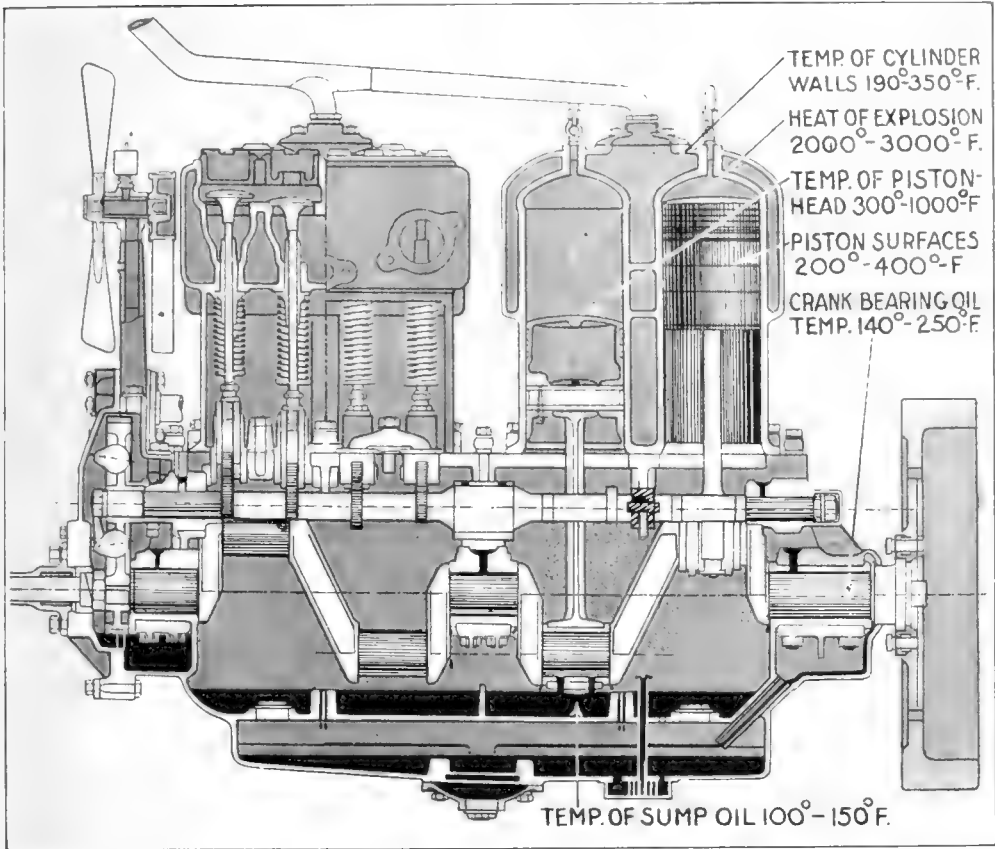

In many cars the Splash Lubricating System is employed. Oil is supplied to the crankcase. The connecting rods dip into and splash the oil to all other parts of the engine. The temperatures of the various parts are indicated in the diagram and show the heat to which the lubricating oil is subjected. The parts that are lubricated are indicated in white.

water and has a curdled appearance; but good oil shows a clean line between the oil and the water. The test indicates whether or not the refiner has removed harmful acid compounds and other impurities.

Of all these tests those which indicate an oil's viscosity and heat-resisting qualities are the most significant, because they show whether or not an oil is able to form and maintain the film that separates the friction surfaces and prevents the escape of gases past the piston during the compression and power strokes.

The accompanying pictures show what happens when poor, cheap oil is used in a motor car—an oil which fails to meet the tests mentioned. If the oil has insufficient body and cannot stand

heat, metal rubs on metal; piston rings break; the cylinder walls are scratched and scored.

An oil of low viscosity is easily sucked past the piston rings into the explosion chamber. That means compression losses, because of the poor gas seal formed by the oil. What is more, the carbon of the oil—the carbon which is an indispensable chemical constituent of every oil is deposited in a more or less thick coat. Subjected to the heat of thousands of explosions in a few minutes, this carbon acts like so much coal. Parts of it become incandescent. Hence, mixtures are prematurely exploded. "Knocking" of the motor results, which means that the glowing carbon ignites the mixture before the piston has reached the top dead center, thus giving rise to powerful blows

on the bearings and the delivery of power in the wrong direction. A trip to the repair shop inevitably ensues, with a big bill.

An oil which has not been selected with a due regard for the requirements of the cylinders is bound to affect the bearings. Unnecessary wear of the main or connecting rod bearings is caused by poor quality of the oil, or by an oil too light in body, or by an oil too heavy in body to reach the friction surfaces, or by an oil unsuited to the method employed for supplying it to the bearings. When each revolution of the crankshaft is accompanied by a dull thump, you may be sure that this wear is manifesting itself.

#### *Selecting the Right Kind of Oil*

The lubricating system of the automobile ought to be but is not standardized. No less than ten different mechanical methods of lubricating automobiles are in use on the various cars made in the United States. Some day the Society of Automobile Engineers will specify one lubricating system for all makes of cars, and when that time comes it will be easier than it is now to select the right kind of oil. As it is the lubricating requirements of each make of car must be studied—a study which involves the construction of the engine; horizontal, vertical, or V type of cylinder arrangement; two or four stroke cycle; bore and stroke; valve construction and arrangement; oiling system; number and fit of piston rings; piston clearance; condition of the bearings; cooling system (air and water); engine speed; and climatic conditions. It is evident that the average automobile owner cannot be expected to have either the engineering experience or the technical knowledge required to consider all these factors. Fortunately the leading oil refiners have made elaborate and special studies of the many motor cars on the market and have prepared lubricating charts, which can be obtained for the asking and which show exactly what oil should be selected for any given make of car. In a few years from now lubricating systems may be standardized with the result that a single oil will answer for all motors.

A well-known motor car manufacturer has given it as his opinion that fully seventy-five per cent of automobile repairs and fifty per cent of depreciation in automobiles may be attributed to poor lubrication. A car costing \$850 is operated at an annual cost of \$416. Of this sum depreciation, repairs, and fuel are represented by \$286. The amount of lubricating oil required in a year does not cost more than \$10. It is the wildest kind of folly, therefore, to save money on the small amount of lubricating oil required to keep down the expense for repairs and depreciation. Cheap oils mean repairs, and repairs mean heavy bills.

#### Spontaneous Explosions Due to Microscopic Plants

EVERY little while an explosion occurs in a subway, sewer or trench or in an electric-wire tunnel or some other subterranean conduit or passageway under such circumstances that it is exceedingly difficult to determine the cause of the accident satisfactorily. Such explosions have often been attributed to sewer gas, which contains a considerable proportion of methane and hydrogen. These gases are exceedingly combustible and quite capable of exploding with extreme violence when mixed with air in the right proportion and fired with a spark or a flame. This much is quite generally admitted; but in many cases the difficulty is to account for the ignition of the mixture, when it appears to be impossible to ascribe it to the action of any recognizable external agent, such as electricity or flame.

It is well known that, during the decomposition of the organic matter in sewage, microscopic plants of a certain kind grow in the mass and act upon it in such a way as to cause about two-thirds of it to liquefy, while the remaining third remains in the solid state. When the conditions are favorable, phosphine gas is occasionally generated in the course of the bacterial action; and this gas, when impure, has the peculiar and unusual property of taking fire spontaneously upon coming in contact with the air. Such a fire spreads with great rapidity.

# A Quaint Cypress Tree Village in Paris



Above, a church, summer-house and various birds fashioned from cypress trees. This has been called the most curious garden in the world

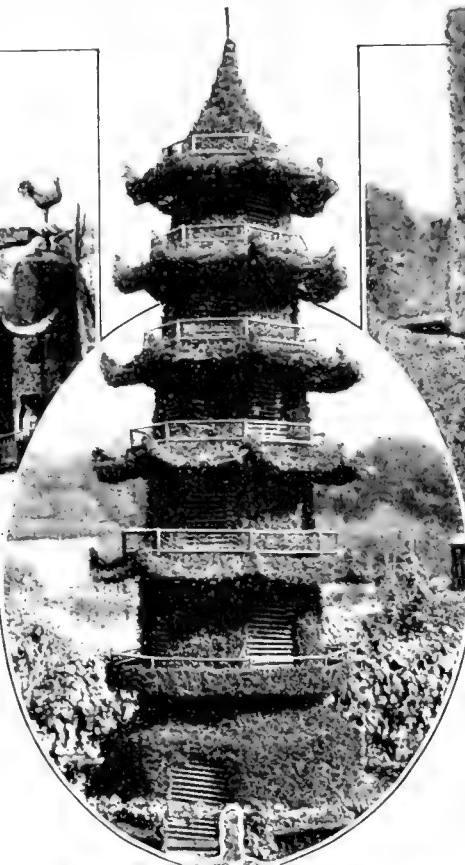

At right, a seven-storied tower which looks substantial enough to be tenanted. It took the gardener several years to bring this to perfection



Above, a well surrounded by a wall of cypress carefully trimmed to retain its shape and growth. This was not so difficult to accomplish

Below, an elaborate and delicate "umbrella tree." Wires are used as a supporting structure for the abundant foliage. The tree trunk is a pole



# Putting the Unprepared "Rookie" Through



A case of unpreparedness. Dr. M. J. Murphy couldn't find a uniform big enough to fit him. He has to drill in his civilian clothes

At top, examining the men with the stethoscope. A staff of army surgeons is in attendance to see that every "rookie" measures up to the stringent physical requirements of the Army before pronouncing him physically "fit"

In oval, teaching a future guardsman how to chop wood. "How to Do the Chores," is one of the most unpopular courses now being taught rich men's poor sons at Preparedness's Plattsburg. On the other hand, a popular course is the class lecture, which is always well attended

# the Preparedness Mill at Plattsburg

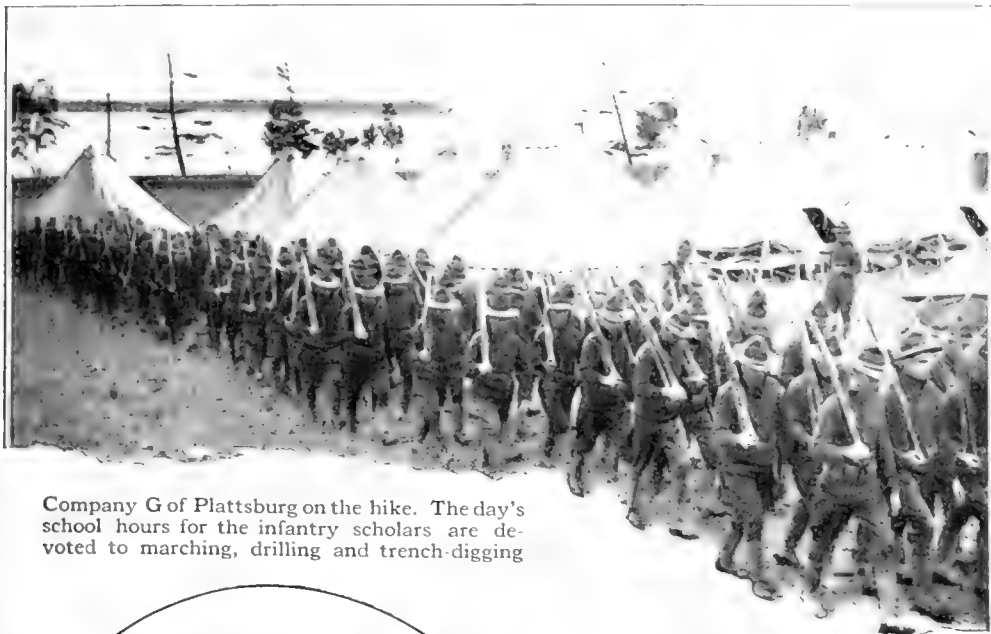

Company G of Plattsburg on the hike. The day's school hours for the infantry scholars are devoted to marching, drilling and trench-digging



Above, the business (not listed in the daily programme of duties) of pulling a big roller from the station to the parade grounds

Teaching a cavalry recruit how to mount a horse without the aid of saddle or stirrups. The horse is guaranteed to be gentle



# What's New in Patents

## Pipe Loaded From Stem



A DETACHABLE pipe in which a specially prepared roll of tobacco is loaded in the stem instead of the bowl is said to afford a cool and non-biting smoke.

Air is drawn in to the burning tobacco through the bowl, and as it is packed up tight against the stem nicotine cannot enter the smoker's mouth. When the roll of tobacco has been smoked the bowl is detached from its stem and the ashes are removed from the loading end.

## Spout Attachment for Bottles

AN attachment applied to the mouths or necks of bottles directs the pouring of the liquid and serves to catch the drip. It is constructed of any suitable material, such as celluloid, sheet metal or the like, and is inclined downwardly and inwardly from its outer toward its inner edge. The arms attached to the spout are provided with loops or eyes to facilitate a clamping engagement.

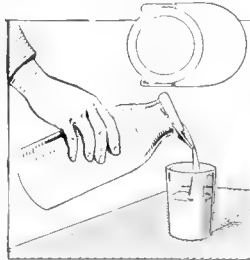

## Automatic Roller Bearing

A ROLLER bearing combining balls and rollers in a manner which automatically compensates for variations in roller diameter has been devised.

The balls are placed in the bearing in two rows, as indicated, and permit of the automatic adjustment of the rollers. The concentricity of the bearing upon its mounting and its housing is secured without compelling extensively close limits in machining.

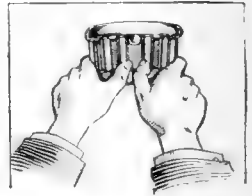

## A Spoon That Can't Slip

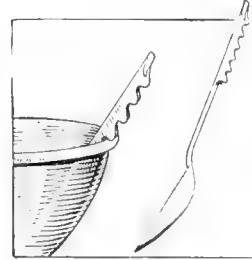

A SPOON has been invented with teeth or serrated edges to enable it to hook upon the edge of a dish and stay in any position in which it is placed. The teeth are in the handle and

are so arranged that they do not interfere with the operation of the spoon. The spoon can not slip down the edge of a pan or dish and become emerged in the contents. Furthermore, it will retain heat as readily as the ordinary spoon.

## A Fancy Shoe-Lace Cover

A SHOE-LACE cover with a bow affixed to its upper end has been devised by a New York man who is fond of decorative ankles. The jaunty bow is to please the aesthetic sense while the cover is supposed

to save the shoe-lace and keep dirt from entering the shoe. The upper part of the attachment terminates in a buckle and belt device which fits tightly about the ankle.



## A Heater for the Parlor Lamp

A LAMP may give both light and heat with the attachment illustrated. It can be applied to an ordinary table lamp, although the construction is applicable to all manners of burners. It can be quickly

fitted to a lamp without any structural changes, and it is so simple in construction that anyone can use it. It gives off a maximum amount of heat when applied to any burner.

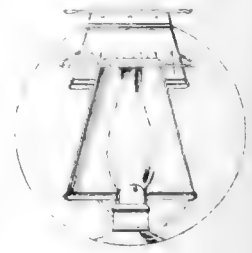

It Ought to be Light

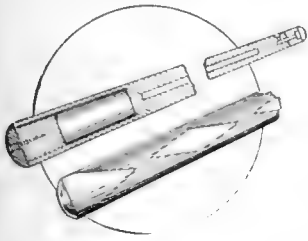

**A**N aluminum billiard-cue has been devised by a Nebraska man who has long searched for a light cue. His cue is

made of aluminum and has a rectangular metal twisted and embedded in the aluminum. It is strengthened by ferrules extending around it which serve to ornament it. The cue is hollow for a portion of its length and is provided with a means for securing the tip rigidly to the striking end.

Beating the Dentist to It

**A** TOOTH-cleaning instrument invented by a Kansas City man has a strand threaded and spanning a portion of the instrument for insertion between the teeth to remove foreign matter. The principal object is to provide a sanitary device with a means for holding the strand in proper tension and removing a portion of it after it has been used and substituting a clean portion.

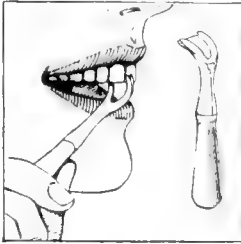

A Cure for Butter Fingers

**A**N instrument has been invented for music learners and all others (except the pickpocket) whose fingers are stiff and won't behave. It is a finger-spreading device which allows the fingers to be lifted, depressed and exercised in a dozen different ways beneficial to the person learning intricate movements of violin and piano playing. The two blocks of wood are fastened to a wood base by screws which may be tightened or loosened at will.

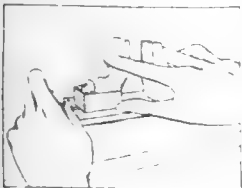

A Swatter for High Fliers

**A**N adjustable swatter designed for use in killing flies, mosquitoes and other insects on the ceiling of a room or on the walls consists of a spring in a rod which forces



the swatter end of the instrument against the insect with sufficient force to kill it. When the knob at the end of the rod is released by the operator the swatter end strikes the wall quickly. The rod is kept in a set position by locking the spring in place. The swatter end may be fastened to the handle with a cord.

Facilitating Speed in Writing

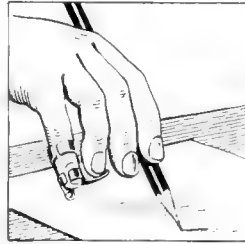

**A**N attachment for the hand has been invented which makes fast writing possible. It is a movable rest for the hand which while facilitating the requirement of

speedy writing secures the steadying effect usually imparted by resting one or more fingers on the paper, but without retardation resulting from the latter practice. Frictional contact of the hand is thus obviated and speed increased.

Automobiling with a Bicycle

**T**HE bicyclist can imagine he's automobiling with a new device which dispenses with the ordinary handlebars and substitutes in lieu thereof a steering wheel which enables the rider to assume an upright and comfortable position and thus obviate injury incident to bending down. The device can be quickly applied to the frame of any ordinary bicycle or motor-cycle to fit riders of varying proportions.

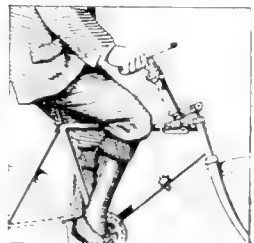

# Winners in the Radio Prize Contest

**O**UR first Prize Contest, which was announced in the April, May and June issues of the POPULAR SCIENCE MONTHLY and which closed on June 15th, brought responses from all over the country.

The first prize, of Twenty-five Dollars in money, has been awarded to Mr. K. B. Warner of Cairo, Ill., for his article on "The Construction of an Amateur's Aerial Mast." This will appear in the September number.

The second prize, Fifteen Dollars in money, was won by Mr. R. H. G. Mathews. His article, entitled "Cures for Trouble in a 200-meter Wave Outfit," will be printed in October.

In accordance with the fourth paragraph of the conditions of the Prize Contest, the Editors have selected and purchased certain other manuscripts. These, to be published in early issues, include the following:

- "An Emergency Aerial," by Mr. A. W. Parks, of Sandwich, Mass.
- "How to Keep the Telephones from Humming," by Mr. D. Broune, of New York City.
- "An Easily Erected Antenna," by Mr. F. M. Meals, of Port Angeles, Washington.
- "A Perfected Slider for Tuning Coils," by Mr. Philip E. Edelman, of St. Paul, Minn.
- "A Noiseless Tikker Receiver," by Mr. W. A. Parks, of Washington, D. C.

All of these articles describe practical ways in which wireless operators and experimenters overcame their difficulties. It will be worth your while to watch for and read every one of them.

The Editors want more articles of this sort, and will pay for them. Write up how you eliminated your wireless troubles, and so help other amateurs and professionals by sending the manuscripts to us to be printed.

Watch the September number for announcement of our new Radio Service Bureau for readers of the POPULAR SCIENCE MONTHLY. Send us your suggestions and inquiries, so that we can be of immediate assistance to you.

# Experimental Electricity

Practical Hints  
for the Amateur



Wireless  
Communication

## A Wireless Telegraph Transmitter with Two Spark Frequencies

ORDINARILY a radio transmitter using a rotary gap sends out its signals on practically a constant spark frequency, and at the receiving station it is often possible to recognize a number of different sending stations by this characteristic alone. It is entirely feasible, however, to change the group frequency of a spark transmitter. One way of doing this by merely pressing a key or closing a switch is shown in U. S. patent 1,175,418 which was issued during the current year to R. A. Fessenden. With a device of this sort the transmitting operator can send messages on approximately half power, by using the lower spark frequency when atmospheric and interference conditions permit.

Should it be necessary to signal through strong disturbances on high frequency of spark tone, the full power is immediately available.

The method of variable group frequency may also be applied to two-tone sending, by using one rate of sparking to signal dots and the other for dashes. In this plan of telegraphing, the length of impulse for a dash is no longer than that for a dot, and the pitch of tone is the only distinguishing feature. Thus messages may be transmitted at a somewhat higher speed. Since the rotary synchronous gap gives absolutely pure tones of spark, the arrangement of this patent should be especially useful for the two-tone signaling system.

The figure is reproduced from the patent specifica-

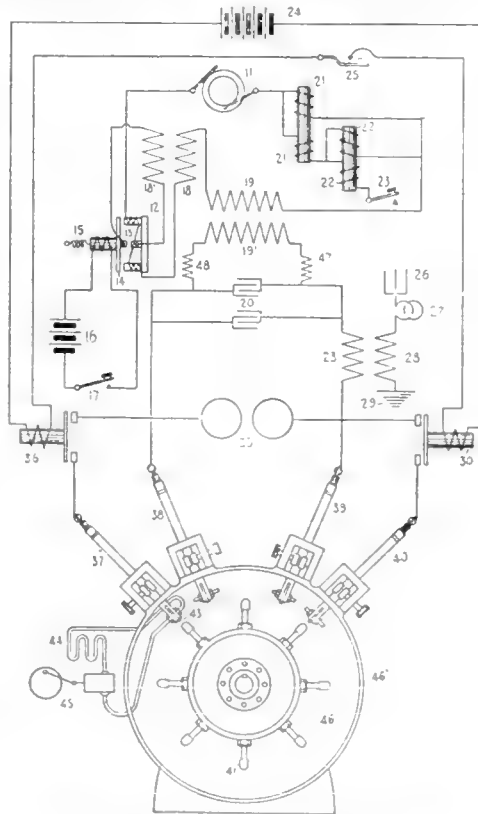
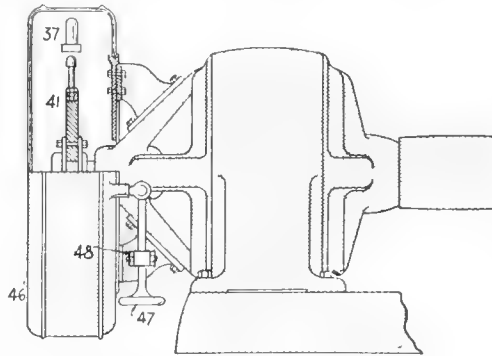

Diagram of the complete transmitter apparatus showing the relations of the various parts to one another

tions, and in it is shown a complete transmitter. Power is conveyed from the generator 11, of approximately 500 cycles, to the transformer primary 19 by way of the signaling mechanisms controlled by sending keys 17 and 23. In the first of these a direct current from battery 16 energizes the magnets of relay 12, 13, 14, whose contacts short circuit a portion of the impedance 18, 18<sup>1</sup> (which is shown as a transformer with the secondary arranged to be shunted by the relay) and thus allow the main current to pass. Windings on the relay contact-arm prevent it from opening until the alternating current passes through zero amplitude, and thus sparking is avoided. The alternative method of signaling is by key 23, which in its lower position neutralizes the impedance of coils 21 and 22 by closing a differentially-wound secondary circuit 21<sup>1</sup> 22<sup>1</sup> and so provides an unobstructed path for the main primary current.

The 500-cycle potential from the secondary of the power transformer 19<sup>1</sup> charges the main condensers 20 through the choke-coils 47, 48. From the condensers the circuit passes through stationary electrode 38, across one spark-gap to the rotor 41 and then back to a second stationary electrode 39. From here the primary oscillations are led through the transformer coil 28 and back to the condenser. The secondary 28<sup>1</sup> is connected to antenna 26 and ground 29 in the usual way, and the ammeter 27 is inductively coupled to the antenna circuit. A protective spark-gap 35 is connected across the main rotary gap, so as to prevent damage from excessive potentials. With connections as outlined, if the rotary gap is provided (as shown) with one spoke for each pair of field poles in the alternator upon whose shaft it is mounted, there will occur only one spark for each complete cycle of alternating current.



A radio transmitter suitable for sending messages on half power by using the lower spark frequency

If, however, a second pair of stationary electrodes 37 and 40, spaced exactly half-way between the first pair (as regards the electrical cycle), are connected into circuit, there will be a spark for every half-cycle. That is to say, by connecting the additional electrodes into the primary oscillation circuit there are given twice as many opportunities for sparks to pass. The change in connection may be made by moving key 25, which controls the output of battery 24 and thus operates relays 36 and 30. When the key is up the transmitter produces 500 sparks per second, and when it is down, 1,000 per second. Thus the signal tone is changed by a full octave, and by mechanically or electrically linking together 25 and 1 of the signaling keys 17 or 23, dots or dashes may be sent at either pitch of spark-note.

The patent also contains nine other drawings showing details of the spark-gap and stationary electrodes with water cooling (such as is indicated by the pump 45 and circulation system 44), types of oscillation transformers for heavy current, variable loading inductances, high and low potential relays, etc. A transmitter in which the alternator produces a high voltage which may be connected directly across the spark-gap is also illustrated and described.

#### A Booth for Long Distance Receiving

**T**ROUBLE is sometimes experienced in receiving the faint wireless signals during rainy weather, on account of the noise caused by the rain pounding on the roof of the wireless room.

This trouble can be overcome by building a small double-walled booth, similar to a telephone booth, within the room in which the outfit is placed. Sawdust should be packed between the walls and ventilation provided by means of two tubes, one in the top and the other near the bottom.

How a Compact Molded Condenser Is Built

U. S. PATENT No. 1,174,600, issued to W. J. Murdock, shows the construction of the molded condensers which have become familiar in wireless telegraph sending stations. By first fixing in position the plates of the condenser and then casting them solidly into a mixture of pulverized mica and resinous gum, the inventor states that he secures a condenser which is compact, strong, efficient and inexpensive. The drawings show how the two sets of plates a, a, a, and b, b, b, are connected to the terminals e and g by means of the strips d and f. The terminal screws pass through conducting strips h, i, which have their adjacent ends beveled and form a protective spark-gap n. The molded dielectric material, c, is uniform throughout and there are no insertions of mica sheets or other separators. Units of convenient capacity and voltage may be made up and combined in series or parallel to meet the needs of any particular transmitting outfit. The condenser has found extended application in portable small-powered quenched-gap senders.

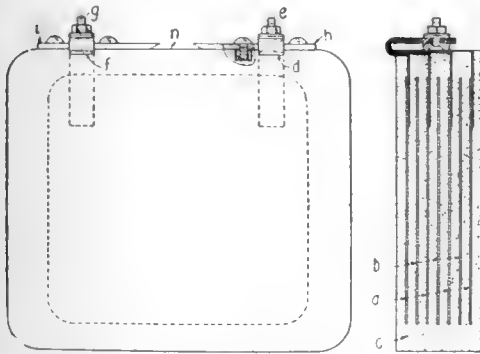

Diagram of a molded condenser for small quenched-gap senders

Small Radio Stations

THERE are in the United States three licensed amateur stations using only five watts input power in their transmitters. Several others use six, eight and twelve watts. It requires about fifty watts to light an ordinary carbon-filament sixteen-candlepower electric lamp.

Primary Regulator for the Induction Coil

The induction coil is shown by A. B represents the battery, and S a five-point switch. M-1, M-2, M-3 and M-4 are magnets from old electric bells. By switching in one or more of these the power used by the coil can be reduced as desired.—C. S. PORTER.

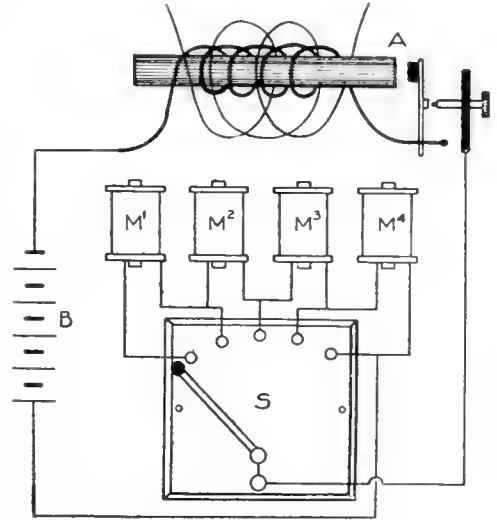

An arrangement for regulating the power used by an induction coil

Cardboard Tubes

A GREAT many amateurs, when making tuners or loose couplers, are puzzled when they come to the cardboard tube problem. They either do not know where to buy the tubes, or cannot make them successfully. However, these tubes can be easily made.

The first thing to do is to get a round cylinder the desired length and diameter and some thin cardboard or thick paper. Wind the paper or cardboard around the cylinder. After the first layer has been put on coat the inside of the paper with glue to make the layers stick together. After the paper has been wound on to 1/8 or 3/16 in. thickness, put elastic bands around the tube to hold it from becoming loose. After the tube has become thoroughly dry take it off the cylinder and coat it with shellac. This process serves to strengthen it appreciably and makes it ready for use.—ALBERT KILLMEYER.

# A Home-Made Edison Battery

THE good points of the Edison battery are great constancy, very low internal resistance and freedom from local action when on open-circuit. Following are the particulars of a home-made Edison battery which can be built very cheaply and which will give every satisfaction.

The battery consists of a perforated copper pipe *A* (Fig. 1), containing black oxide of copper as the positive element, and a zinc cylinder *C* as the negative element.

The exciting liquid is a 25-per cent solution of caustic potash in water, which means a solution of one pound of caustic potash to three pounds of water. The containing jar is represented by *D*; *E* is a cover which excludes dust and from which the copper pipe and zinc cylinder are suspended by means of the brackets *F* and *G*. The two binding posts *H* are connected to *A* and *C* respectively.

The battery here described, which will give a constant current of 20 amperes, uses a containing-jar 6 ins. by 10 ins. In building this battery it will be best to obtain the containing jars first, since all the other dimensions are fixed by the size of the jar.

First procure a copper tube of 3-in. bore and  $8\frac{1}{4}$  ins. long, about  $\frac{1}{32}$  in. thick. To perforate the tube, slip it over a stick of wood a little smaller in diameter than the tube; punch the holes through with a punch or a nail. The holes should be about  $\frac{1}{8}$  in. in diameter.

Cut a wooden disk 3 ins. in diameter and about  $\frac{3}{8}$  in. thick. Drill a  $\frac{1}{4}$ -in. drain-hole in it and soak it for about fifteen minutes in molten paraffin wax. Then fix the disk with shellac solution in the bottom end of the copper tube.

Procure some copper strip about 1 in. by  $\frac{1}{8}$  in. Bend 3 lugs, *G*, as shown, and rivet them to the copper cylinder. The

lugs must be equally spaced (Fig. 2), showing the drilling in the top cover *E*, where *X* represents the holes for supporting *A*, and *Y* the holes for supporting *C*.

The copper cylinder is now completed and we take next the zinc cylinder in hand. This should be made from rolled zinc and not from cast material. The best plan is to buy a cylinder of the size required as you are sure to get the right material. Preferably the zinc should be well amalgamated as it lasts much longer. Three lugs made from the same strip as used for the copper cylinder should then be riveted to the zinc cylinder. They must be again equally spaced as shown in Fig. 2.

One lug on each copper and zinc cylinder should then be soldered to the respective cylinder in addition to the riveting, so as to make as good a connection as possible. These two lugs are the ones subsequently connected with the binding posts *H*.

The cover *E* is now the last part to be made. It is made from good hardwood to the dimensions given and should be a snug fit in the containing jar. Six holes  $\frac{1}{4}$  in. in diameter are then drilled in the cover and spaced as shown in the figure, so as to avoid a short-circuit between the lugs *G* of the copper cylinder and the lugs *F* of the zinc cylinder.

The cover must now be soaked in molten paraffin wax for at least fifteen minutes. Then obtain two large binding posts *H*, ten  $\frac{3}{16}$ -in. nuts, 6 washers for the same and 6 steel rods, screwed  $\frac{3}{16}$  in. on each end, one end to take the binding posts or nut on top of the cover *E* and the other end to take the nut below the brackets *F* and *G*.

In assembling the battery, first fill the copper cylinder with black oxide of copper and bolt the cylinder to the cover *E*. Fix the zinc cylinder *C* to the

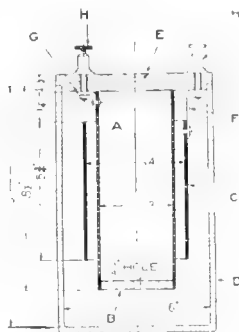

Fig. 1. Dimensions and parts of the battery

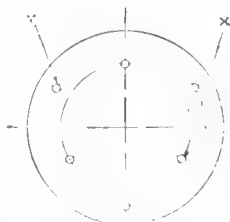

Fig. 2. Proper position of the lugs on the cylinders



cover and fill the containing jar to about 1 in. from the top with a 25-per cent solution of caustic potash in water. On top of this solution pour a layer of heavy paraffin oil about 1/2 in. deep to exclude the air and prevent creeping.

The battery is now ready for use and needs no attention whatever till it is exhausted and all the oxide of copper reduced to metallic copper. This is of great purity and is worth a good price.

The 25-per cent solution of caustic potash is best made up in the following way:

First ascertain how much water the container will hold when the filled copper cylinder and zinc cylinder are in place. Pour off about a third of the solution and put in the amount of caustic potash required. Stir very gently, since a drop of that solution in your eye might cost you your eyesight.

### A Clever Window-Display

**A** MYSTERIOUS window-display which attracts passersby and holds their attention consists of an opal ark-lamp globe practically full of water in which an incadescent lamp floats tip up. At short intervals the lamp lights up brilliantly and at the same time submerges itself in a very mysterious way. After a few seconds it bobs up and its light practically fades out. This cycle is continued indefinitely. The only explanation for the odd movements of the lamp seems to be some bared wire ends projecting over the edge of the globe, giving the idea that it is regulated in its movements by wireless influence.

The true explanation of the device is as follows:

A field coil from an old dismantled motor was placed in a box and within was put an iron core. A small iron pulley was actually used for this. An iron bolt was put through the box cover into the center of the core and the wires for feeding the lamp run through the cover alongside the bolt. The lamp was connected in series with the coil; the wires were soldered to the lamp base and well protected by rubber tape. To seal the bottom of the globe it was put on a rubber sheet and a layer of sealing compound filled in; an electric soldering

iron was used to work the compound well around the edge and about the bolt head to make a water-tight seal.

Fastened to the lamp base by a loop over the tape was an iron wire with the lower part arranged in spiral form; this was of just the right weight to keep the lamp about half submerged when the current was off. Connected into the circuit was a Thermoblink flasher which periodically cut the current in the lamp and coil circuit down to a low value. As the current was restored to full value,

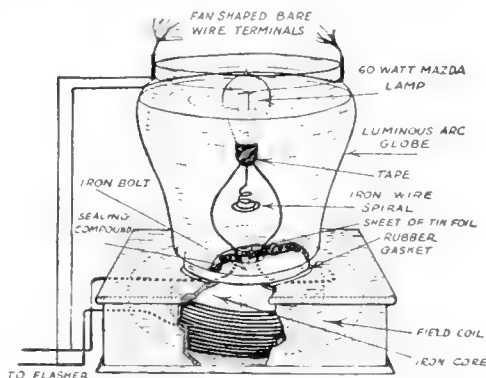

The mysterious electric lamp which glows brilliantly one moment and the next fades away beneath the water

the coil was energized and the iron spiral with the lamp was pulled down toward the bolt head, a sheet of tinfoil over the latter preventing actual magnetic contact and sticking due to residual magnetism when the current was again cut down to its low value.

The box on which the globe was placed and the wires really leading to the coil and lamp were covered by a cloth, leaving very conspicuous, however, the wires on the outside of the globe to the antennalike ends.

### Lowering the Decrement

**T**HE present radio laws require that every transmitting station shall emit "sharply tuned" waves. The logarithmic decrement must be less than 0.2. The smaller this decrement the more waves in each wave-train and the sharper the tuning. With a decrement of 0.2, which is really quite high, there are only 12 1/2 waves in a wave-train before the amplitude has fallen off nine-tenths.

## Music by Wireless

UNITED STATES Patent 1,166,582, issued in 1916 to G. Desilets, shows an interesting "Wireless Apparatus for Producing and Transmitting Musical Sounds." By the use of this method, which is here shown diagrammatically, it is possible to play tunes the same as on a piano, and to have the music thus played transmitted by wireless to a distant station and there reproduced. It is seen that alternating current power lines are led to the primary of transformer 43 by way of the special piano-keyboard switches shown at 22. All of these are connected in parallel, and closing any of them serves to apply power to the transformer. The secondary charges condenser 47, which discharges with oscillations through the primary portion of helix 46 and which-ever of the rotary spark gaps 3 to 10 is connected by the high-voltage switches of keyboard 22. It may be noted that in the drawing of the patent itself the condenser and spark gap are incorrectly connected to the helix and transformer; from the specification it is obvious, however, that the wiring shown was intended.

The novel points of the system are in the rotary gaps 3 to 10 and in the keyboard 22. Each of the gaps has a different number of spokes, and the numbers are chosen so that the spark frequencies correspond to the notes of an octave in the musical scale. Thus if key 23 is pressed, disc 3 is connected; if this disc has 10 spokes and if the shaft revolves about 1500 r.p.m., 250 sparks per second will be produced. Since the spokes are evenly spaced, the sparks will occur regularly, and a musical note of about middle C on the musical scale will be produced. If key 30 were pressed, double the number of sparks would occur per second, and the musical tone would be one octave higher. Similarly the other keys connect the other gaps, which have their spark frequencies properly chosen so as to give the various notes of the scale. When more than one octave is desired additional gaps are made use of; instead of increasing the number of spokes indefinitely the inventor prefers to duplicate the octave of gaps but to rotate the next higher group at double speed. This of course doubles

the spark frequency and therefore doubles the pitch. By supplying sufficient power it is feasible to play chords by pressing several of the keys at the same time. The loudness of the musical tone can be regulated by rheostats operated by pedals and connected so as to vary the intensity of the sparks. It is easily seen that the radiation from a transmitter of this sort would produce musical tone effects in any receiver, using a telephone in combination with any of the usual rectifying detectors.

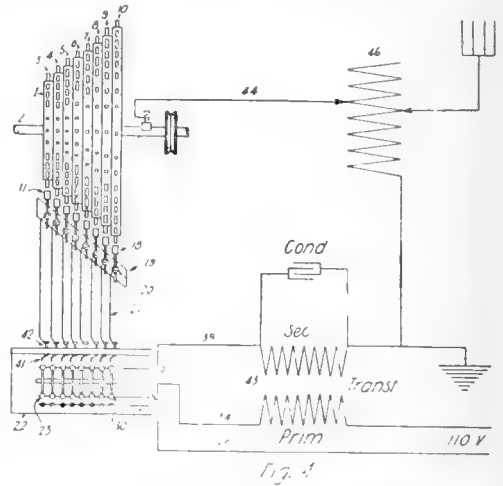

Music may be transmitted by means of this wireless apparatus

## Lighting Audion Bulbs Cheaply

AMATEURS who are not fortunate enough to possess a storage battery often light their audions by the current from dry cells. When the detector is used for any length of time, however, the expense of this method is almost prohibitive. The following is suggested as an exceedingly inexpensive substitute, which may be used by those who can secure worn-out dry cells:

Cut the tops from five one-quart jars or bottles, and fill them one-third to one-half full with a saturated solution of sal-ammoniac. Next scrape all the shellac from the zinc of five old dry cells, and punch 1-8 inch holes about an inch apart all over the shell. When these cells are placed in the prepared solution they will light the bulb nearly as long as a new battery, and at an expense of possibly two cents for the chemical.

Five Examples of Alarm Work

THIS may be done by arranging the circuits as shown in Figs. a, b, c, d, e. Usually when it is necessary to employ a constant ringing method on a call system, an annunciator is also installed and a point provided on the annunciator for each place where a call is turned in. This is shown in all of the diagrams.

In Fig. (a), a constant ringing bell is used. This type of bell is a combination of the vibrating bell and the automatic drop. Its operation is as follows: the circuit is taken through the push-button and a point on the annunciator, then through the coils in the bell and back through the battery.

In Fig. (b) practically the same operation takes place except that the bell and the drop are separate.

In Fig. (c) the diagram is based on another principle. When the push-button is closed, current flows through the coil of the relay. The bell is parallel with the relay. This will cause the armature to be drawn up,

closing the circuit through the armature of the relay and the frame. This will close a circuit through the coils on the relay and the bell continually. As there is a circuit through the coils the armature will be drawn up and held there as long as the current flows.

In Fig. (d) is illustrated a closed-circuit alarm. To be adapted to a call system

it must be connected as shown in Fig. (e). The current flows through the contacts and the coils of the relay to the armature of the relay to the frame of the relay and back to the battery. The platinum point of the relay is toward the coils and the armature must be drawn over toward the coils before the circuit is complete. Once completed it will be held by the action of the armature. A switch is provided for closing the circuit. The bell is connected across another battery, although it could be connected through the same one. The current for the bell passes through the armature of the relay and the extra platinum point on the relay which is insulated from the frame. As the circuit through the contacts is broken, the spring will pull the armature away from the contact point toward the coil and against the contact point to which the bell is connected.

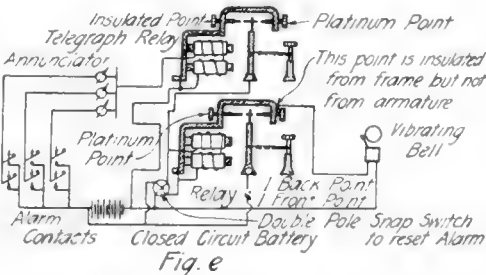
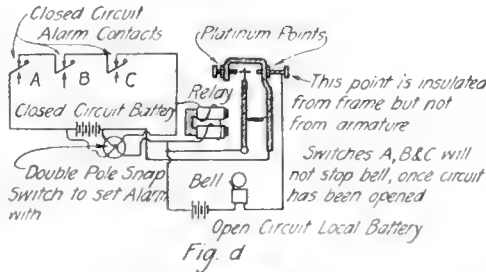
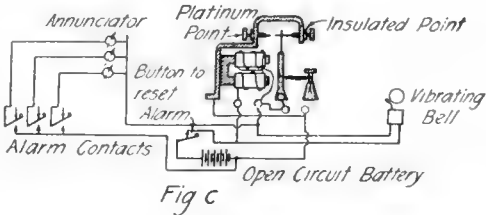
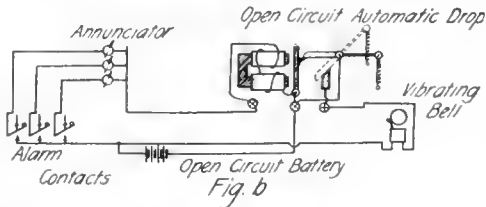
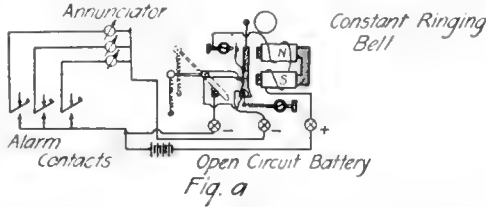

Wiring diagrams of a five-bell electric annunciator system

### Telephone Headbands

THE accompanying drawings show a simple but very substantial pair of wireless headbands. All the materials needed are six pieces of spring brass (they may all be of the same thickness), two binding posts, four washers and two rivets.

Procure about 40 ins. of strip brass,  $\frac{3}{64}$  in. to  $\frac{1}{16}$  in. thick and about  $\frac{5}{8}$  in. wide. Out of this cut two pieces  $12\frac{1}{2}$  ins. long. Round all ends and in one end of each drill a hole  $\frac{3}{16}$  in. in diameter. In the other two ends cut a slot  $2\frac{1}{2}$  ins. long and  $\frac{1}{4}$  in. wide. This is done by drilling a series of holes with a  $\frac{1}{4}$ -in. bit as close to each other as possible, the entire length of the slot. The "tooth" edges remaining may be filed away or cut away with a cold chisel and then filed smooth. Do this carefully as a neat slot adds much to the appearance of the headbands. Now bend both pieces in the shape shown in Fig. 2, and these pieces are finished.

Next cut two pieces of the same material  $1\frac{3}{4}$  ins. long and round the ends. Drill a hole  $\frac{3}{16}$  in. in diameter in both ends and bend one back at right angles,  $\frac{5}{16}$  in. from the extremity (see Fig. 2).

Now cut two more pieces  $4\frac{1}{4}$  ins. long. These should then be cut to  $\frac{3}{8}$  in. wide. In the center of each piece drill a hole  $\frac{3}{16}$  in. in diameter. File or cut the ends to the pointed shape as indicated at C, Fig. 2, and bend the pieces as shown.

All cutting is now finished and the pieces are ready for assembling according to Fig. 2.

Secure two binding posts as much like those illustrated as possible. Put one of these through the hole in the straight end of B so that it points in the same direction as the small leg of B. Now put on piece A by slipping the end with the drilled hole over the binding post on top of B. Next put A<sup>1</sup> in the same manner, on top of A, and then add a washer and screw the top of the

binding post on tightly. Do the same with piece B<sup>1</sup> and the slotted ends of A and A<sup>1</sup> only slipping the binding post through the slots about  $\frac{1}{2}$  in. from the end.

Take a small rivet and put it in the hole in the other end of B and then through the hole in C so that C is underneath. Slip a washer over the free end of the rivet and flatten with a hammer. Do not make it too tight as C should turn freely. Do the same with the bent end of B<sup>1</sup> and piece C<sup>1</sup>.

Adjustment is made at the binding posts for widening the bands; at the slots for shortening them and the 'phones swivel at the rivets. Polish the brass or have it nickel-plated. A good-looking, well-working pair of headbands is the result of about one hour and thirty minutes' work and an expenditure of twenty-five cents.—CHAS. T. WANDRUS.

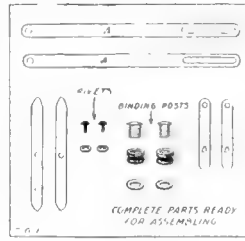

The brass bands, rivets and bolts needed to make the headbands

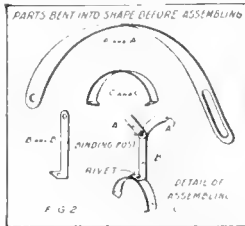

How the metal strips are bent and riveted together in assembling

### A Substitute for an Aerial

IT often happens that the amateur wireless experimenter finds his aerial is too small to be efficient on long waves, although it may be all right for short waves. It is sometimes impossible to erect an aerial suitable for long waves. It has been found that by connecting rain pipes to the receiving set with a single wire lead-in, a fairly good aerial is had for waves over a thousand meters. Arlington, about 1400 miles distant, came faintly on a regular 100-foot aerial using loose-coupler and loading coil, while using the rain pipes that station was heard sharp and clear with a little over half of the primary of the loose-coupler in circuit. The lead-in should be connected to the pipe nearest the instruments. This scheme may not work every time, but if the amateur has access to a system of ungrounded rain pipes it may pay him to try. Where the amateur can not utilize rain pipes the ordinary lightning rod, if it is installed correctly and is not broken in its entire length, will serve as an aerial in place of the more convenient rain pipes.

# A Built-Up Wireless Mast

THE following article tells how anyone possessing ordinary working tools, can easily, quickly and inexpensively construct a mast of a distinctly modern type not usually found at amateur stations. Since it is built of wood, the mast is light and easy to erect. It can be readily used in close quarters, since it requires few guys, and consequently it can be placed quite close to a fence, building or wall.

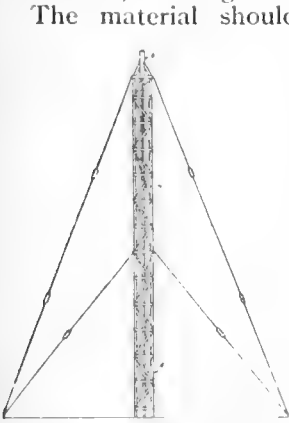

Note how the mast is built up in sections

The material should all be clean, straight, white pine, since this wood will withstand severe weather. All the strips are 1 in. by 2 ins. in cross-section, and may be bought at any lumber yard. The prices range from 1 to 3 cents per lineal foot.

The mast should be built on a perfectly flat place, such as a large floor or level concrete sidewalk. First, three pieces of the material about 1 in. long are sawed off and nailed on the floor to form an equilateral triangle measuring 24 ins. on a side, as shown at *A* Fig. 2. Next cut off 39 pieces, each 24 ins. long, for the cross-pieces *B*, *C*, *D*, shown in Fig. 2. The ends of these pieces are notched to fit in the triangle formed by the pieces *A*, as shown in Fig. 3. Each cross-member should be fitted, and when three are finished, they should be marked as one set and put aside. In this manner 13 sets are made.

When these cross-members are all done, start work on the uprights. Each upright should be 47 ft. long and made by joining several strips by means of scarf joints at least 6 ins. long, using No. 14 wire brads 3 ins. long.

Having completed the uprights, the cross-members may be put in. The first set is 1 foot from the bottom, and

the remainder are 4 ft. apart. The last section, *F* in Fig. 1, will be 2 ft. long in the 50-foot mast. Next put in the braces from corner to corner, having them tight and butting against the cross-members. They must be firmly nailed in place, both to cross-members and uprights. The ends are to be chamfered off to fit the corners, as shown in Fig. 4.

The main part of the mast is now finished, and the pole may be put on top. This is a piece, preferably of oak, 2 ins. by 2 ins. and 18 ins. long. The top is chamfered off to shed water and the bottom made triangular in shape, so as to fit the step on the top of the mast, as shown in Fig. 6. The three pieces, *P*, *P*, *P*, are of the same material as the mast, and are fastened on the bottom side of the top cross-member, set by means of screws, as shown. The six-sided piece *F* is fastened under the three pieces *P*, *P*, *P*, and acts as a bottom for the step. The mast is braced by three pieces shown at *G* in Fig. 1. These rest on the ends of the

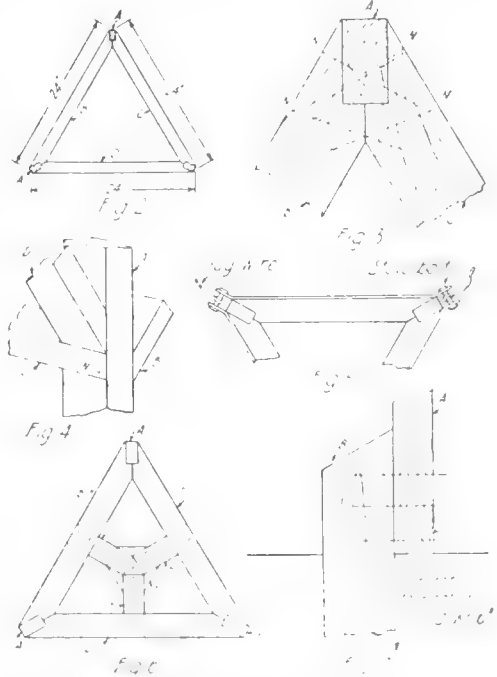

Diagram showing the construction of the built-up wireless mast

uprights *A, A, A*, and are firmly toenailed to them. They are further strengthened by three pieces of iron, each 6 ins. long, and 1 in. by 8 ins. These are bent to fit the angle of the outside of the uprights and the piece *G*, and are then fastened by screws to both.

More iron of the same size is used to make the guy-wire hooks, as shown in Fig. 5. Six are required to be fastened to the cross-wires as indicated. Carriage bolts are inserted through holes drilled in the ends, and the wires are attached to these bolts. Obviously, the guy-wires are attached before raising the mast, and may be broken up by insulators as usual. No. 10 or 12 galvanized iron wire is good for the guy-wires, the lower ends of which should be fastened to heavy stakes, trees or "dead men." A good anchor is made by burying about 3 ft. of telephone pole, with a stout wire fastened around it, some 3 or 4 feet deep (crosswise or horizontally). The guy-wires may be fastened as close as 20 ft. to the base of the mast, but should be farther away if space and conditions permit.

Since the mast is rather light, a heavy foundation is not necessary. A good foundation can be made by digging a hole somewhat larger than the mast and about 2 ft. deep, and filling it with a cinder or stone-concrete mixture, leveled off on top. Three pieces of pine, 3 ins. by 3 ins. and about 1 foot long, should be embedded in the concrete about 6 ins., forming a triangle the size of the inside of the base. When the mast is set over these, the three uprights may be nailed to them as shown in Fig. 7, thus keeping the foot of the mast on the foundation.

A pulley should be attached to the top of the mast by means of an eye-bolt through the pole. A good half-inch manila rope is best for the halyard. The rope should be twice as long as the mast and spliced to prevent its pulling out at the top. This pole is very stiff, if carefully constructed, and may be picked up by the extreme ends without bending. In raising, there should be a man at each guy-wire to keep the mast straight. If it is to be near a building, a block-and-tackle may be rigged up on the side of the building

and the mast raised by hauling on the top or middle. If no such conditions exist, it may be pushed up with poles in the way a telephone pole is handled. Painting, preferably with whitelead, should, of course, be completed before erecting.

The builder will find the mast much easier to construct, once he gets started, than he may at first imagine. The first mast of this type ever built has been up for some time, and has weathered several hard windstorms, in spite of the fact that the two guy-wires which carry the strain are in a line that is not more than 12 ft. from the base.—C. S. ROBINSON.

### A Sending Condenser

A GREAT many amateurs try to use glass fruit jars of brine in a tank or pan of brine but after a trial give up this scheme because of the brush discharge and the bother of frequently having to replenish the water. If enough automobile lubricating oil is poured in to make a layer of about one-half inch on top of the salt solution, the evaporation and most of the brush discharge will be stopped. The inside brine acts as the inner coating of a Leyden jar, and the salt water in which the jars stand takes the place of the outer coating. The drawing shows how to connect for high or low voltage.

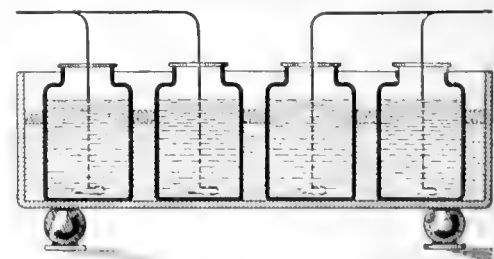
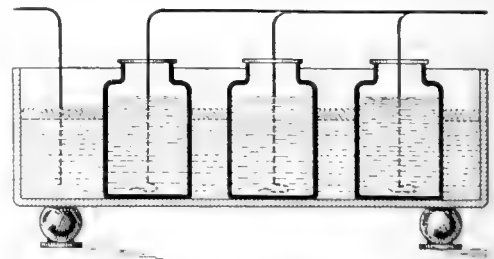

**Rectifying Alternating Current**

**A** NEW machine designed to rectify alternating current at live voltage into direct current at arc voltage has been placed on the market. It involves a radical departure from all former prac-

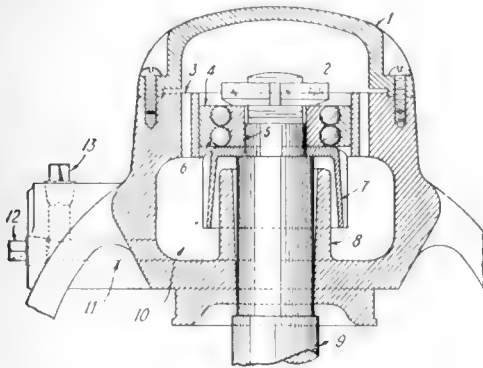

Ingenious machine changes alternating current into direct current without perceptibly decreasing the light

tice in motor generator sets, as applied to motion picture projection. The armature sets in vertical position, or stands on end, and is carried or supported on ball bearings. The direct current generator is of the inter-pole type, there being four inter-poles and four main poles. The inter-pole feature is an important one since it makes possible the handling of heavy fluctuations in current without sparking at the brush, or with sparking reduced to a minimum. It acts as an aid to commutation, and at the same time produces a constant current characteristic which is most desirable for projection work.

In order to reduce vibration and noise the vertical type of construction is used. The ball bearings greatly reduce the friction load, which partly accounts for the high efficiency. In order to secure a perfect armature balance the manufacturers test each machine in a dynamic balance at a speed of seven thousand revolutions a minute, which is approximately four times full load speed. The forced ventilation produced by the fan between the motor and the armature keeps the machine cool.

One of the important features of the equipment is the ability to dissolve from one lamp to the other without a perceptible decrease in the light. The

machine is so arranged that the operator can change from one lamp to the other before it is possible to heat up the carbons of one lamp with say, fifteen amperes, while operating the other lamp at fifty amperes. While the machine is only rated for constant duty as a fifty ampere equipment, yet it is designed to stand eighty amperes during the change, providing that change does not occupy more than five minutes.

The construction of the upper bearing is shown in the accompanying illustration, in which 4 and 5 form the inner and outer shell of the ball-race carrying-balls 6. The inner race 5 is locked to armature shaft 9 by nut 2 and revolves therewith. The outer race 4 sets in a recess in the main frame casting and is stationary. Ten is an oil-well, and 7 is an oil-thrower, which is locked to the shoulder of shaft 9 under inner ball race 5 by nut 2, and revolves at armature speed. The action is that the oil is, by centrifugal force, thrown up through passage 3, whence it descends through and around balls 6 by gravity, thus flooding the entire bearing with a constant stream of oil. Thirteen is the plug which closes the upper end of passage 11 through which oil-well 10 is filled. Twelve is a plug through which oil-well 10 may be drained and washed out with kerosene.

**Adjusting Handles**

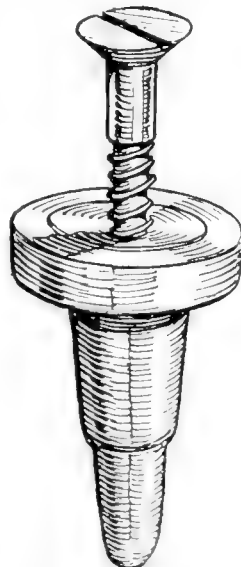

From ink-bottle top to insulator

**T**HE composition tops of drawing-ink bottles may be conveniently used for insulated handles for many instruments by drilling a hole in the center and inserting a brass screw. These look like hard rubber and are very serviceable. Under constant use they will wear as well as most insulators now in use and when broken can be thrown away as useless.



### Making an Electric Fire Alarm

A SYSTEM of fire warning illustrated herewith may be installed at little expense. The installation makes use of mercury, and it can be quickly adjusted and requires no resetting. The detecting mechanism is clearly shown in Fig. 1. It consists first of a glass tube *A* about 2 ins. long and having a bore of 1/8 in. or a trifle more. A short piece of brass rod that just fits the tube has a piece of copper wire soldered to it 4 ins. long. The rod is fitted into the tube as shown at *B* and the end of the tube is filled with sealing wax *C*. The rod should not fit too tight or its expansion will break the tube.

A small rubber cork that fits the tube tightly has a needle run through it. A short length of wire should be soldered to this needle as shown in the drawing. The tube is fastened to a base measuring 1 1/2 ins. by 3 ins. by means of a brass strip *F* and two small screws. Binding posts are mounted on the base and the wires connected to same.

A few drops of mercury are put in the tube and the rubber cork and needle inserted as shown at *D* and *E*. By regulating the distance between the needle and the surface of the mercury the temperature at which the alarm is given can be regulated.

A good method of adjusting this apparatus is to connect a bell and battery to the terminals. Place the instrument and a thermometer in an oven or sand bath and adjust the needle so the bell just rings when the thermometer registers 110 degrees F.

In Fig. 2 is given three wiring diagrams that may be used with this apparatus.

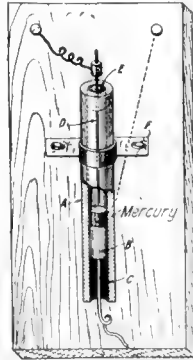

Fig. 1. The fire detecting mechanism complete

At *A* is shown the fire detectors connected in with the regular burglar alarm system which is the easiest way of installing the apparatus. At *B* a third wire is run and two bells are used so that the householder can determine whether it is a fire or burglar alarm. The bells should give a different note and this can be done by placing a wad of paper under one or by sawing a slot. The third diagram *C* shows the instruments connected for fire alarm only.

An added feature refinement would be an indicator to show at a glance where the alarm is coming from. Note particularly the three-point switch in diagram *C* which enables the owner to test the bell and batteries by placing it on point 1. Placing it on point 2 puts the system into service and point 3 can be used as a ground test for the wiring.

### A New Detector Material

SINCE the mineral type of detector was first discovered, attempts have been made to use artificial substances in place of the natural minerals, but as a rule these preparations are much less sensitive. A European inventor claims to have found a mixture that produces a very good substitute for mineral, and which is quite as sensitive. Besides, the effect is claimed to be uniform all over the surface. To make this, mix two parts of pulverized galena with one part of natural mineral silver in the shape of filings, then add stibine and sulphide of silver. When an intimate mixture has been obtained, put into a test tube and heat to white heat. Temper while hot in ammonia water and remove the compact mass, which may then be mounted for the detector in the same way as a piece of mineral.

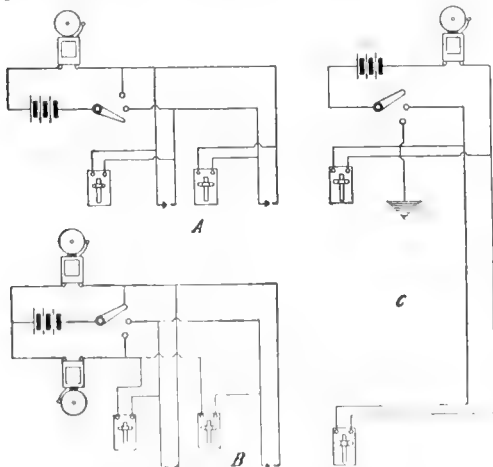
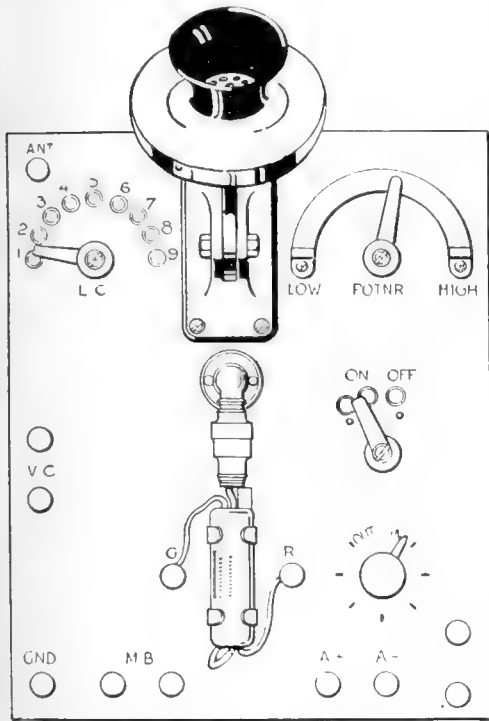

Fig. 2. Three methods of wiring which can be used with this apparatus

Modified Audion is New Telephone

THE newest oscillation generator to be used in radio telephony is a modification of the Audion detector, which Dr. Lee de Forest, its inventor, calls the Oscillon. As applied to a low-powered transmitting instrument, this device consists of a tubular bulb con-



A modification of the audion detector used for wireless telephone transmission

taining a straight filament surrounded by a helical grid and cylindrical plate.

The illustration shows a small panel Oscillon Telephone. The front dimensions are only about 8½ by 11 ins., yet the assembly includes the Oscillon bulb itself, a telephone transmitter, a potentiometer for adjusting the high potential applied to the plate circuit, a switch for starting and stopping the oscillations, a rheostat for the filament current, a switch (at the upper left-hand corner) controlling the radiated wavelength by cutting in more or less of the variable loading coil mounted back of the panel, and binding posts for connection with the antenna and ground.

Reducing Arcing at Key Contacts

USING a sending key on the 110-volt circuit gave much trouble because of arcing at the contacts. This difficulty was remedied by placing two horseshoe magnets on opposite sides of the contacts. It was found that the magnets should be close to the contacts but should not touch them. The magnets were fastened on blocks of wood, with brass strips, as shown in the cut below. By their use, the arcing was decreased considerably. Stronger magnets or powerful electromagnets would be still better.—B. SCHUMM.

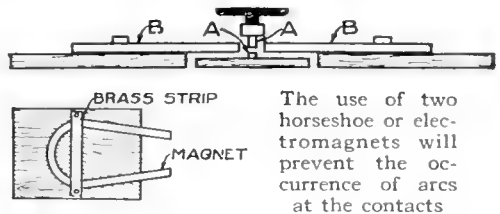

The use of two horseshoe or electromagnets will prevent the occurrence of arcs at the contacts

A Good Loose-Coupler Switch

THE diagram shows a loose-coupler switch which will positively stay tight. In the illustration, A 1 and A 6 are nuts of which A 1 may be used to elevate the knob. Note that A 4 holds A 3 in check. The nut A 5 may be omitted. The knob B is an ordinary wooden disk used in the game of checkers. The bolt C is of brass or nickel, and D 1 and D 2 are copper or brass washers. The washers are stationary but the nuts move with the knob. The strip of thin copper or brass E has its edges beveled at the contact buttons. The contact bolt is marked F and the contact wires X 1 and X 2. This arrangement is not only cheap but easily constructed. When the various parts of this switch are connected it will remain tight under all working conditions, necessitating no additional care.—F. C. HAMILTON.

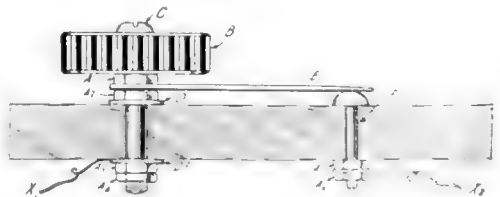

A tight loose-coupler switch

**A Quenched Gap with Metal Spacers**

**I**N designing quenched spark-gaps a number of inventors have attempted to produce dischargers in which the spacing of plates, or length of gap, would not be determined by the pressure applied to the gaskets separating the elements of the gap. When thin press-board or rubber composition gaskets are used under heavy pressure, the gaps sometimes become too short. This is especially likely to happen when the apparatus grows hot after long use. A method of construction patented by R. Pfund in late 1915, and shown in specification 1,161,520, from which Fig. 1 is reproduced, avoids some of these troubles by using metallic spacing-washers. The gap elements are made up, as shown in this drawing, from base plates 4 which have attached to them the raised sparking-surfaces 18. Insulating-rings 5 support metal rings 6, and, after the half unit consisting of 4, 18, 5 and 6 is assembled the active gap surface 18 is turned off so as to be exactly in the

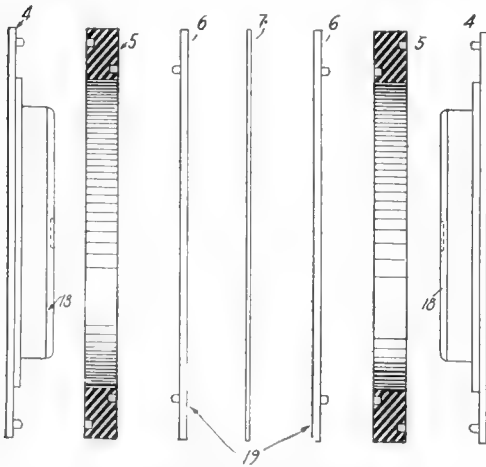

Fig. 1. Metallic spacing washers used in the new quenched spark-gap

plane of the ring 6. Thus, when the metal spacing-washer 7 is inserted, the two sparking surfaces are held apart by it at exactly the right distance. Heat will not affect the washer 7 to any great degree, and its thickness can be made more nearly uniform than when thin insulating material is used. Of course, the true spacing will be held only so long as the insulating-rings 5 hold their

shape; these, however, are far more rugged than the usual gaskets.

The complete assembly of the gap is shown in Fig. 2. Units built up as in Fig. 1 are supported upon the two lower rods 10, and between them are inserted

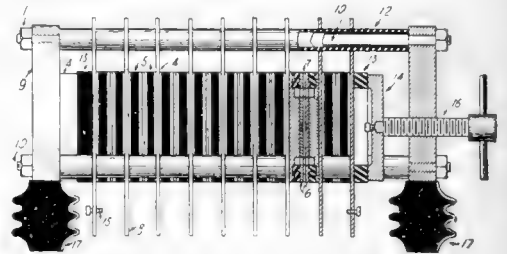
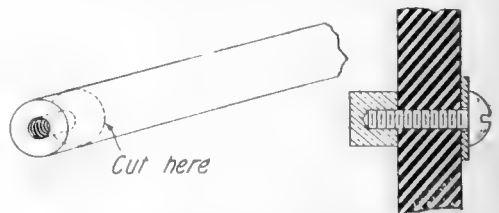

Fig. 2. The single units are built up in this form to complete the gap

larger cooling plates 8. The compression screw 16 serves to make the gaps practically air-tight, in the usual way. This construction makes demounting easy, since, immediately upon loosening 16, any of the elements may be removed for inspection or cleaning, without disturbing the cooling plates or the other gaps. If, when rubbing down the surfaces, the entire assembly 4, 18, 5 and 6 is slid over a flat polishing cloth, the active plane is maintained accurately in line with the surface of disk 6. The constant and accurate spacing maintains adjustments which give a clear spark tone.

**Switch Points for Radio Instruments**

**V**ERY neat and serviceable switch points may be made of round brass rod of the diameter to suit one's requirements. All that need be done is to drill and tap the end of the rod and then cut off the length giving the desired height of switch points. A machine-screw is to be used for fastening it to the instrument panel.—LOUIS LIND.



Make your switch points from pieces of brass rod by tapping the end and cutting it off at the proper length

# What Radio Readers Want to Know

## Receiving Condensers; Loading Coils; Transformers

E. C. M., Philadelphia, Pa., inquires:

Q. 1. Why are variable condensers of the rotary type used in preference to the sliding plate variable?

A. 1. Because they are usually better mechanically.

Q. 2. Please give a formula for finding the capacity of a variable condenser and a condenser of fixed value.

A. 2. You are referred to any of the standard textbooks. It is not possible to compute this capacity with absolute accuracy, in most cases, and the best plan is to have your condenser measured and calibrated at a radio laboratory.

$$C = \frac{K}{900000} \frac{u^2}{4s} + \frac{u}{4H} \log \frac{16 \Pi u (s+w)}{s^2}$$

$$- 1 + \frac{w}{s} \log \frac{s+w}{w}$$

Where:

u = radius in centimeters

s = separation of plates in centimeters

w = thickness of plates in centimeters

K = dielectric constant of the separating medium

C = capacity in microfarads

For the capacity of a number of semicircular plates we calculate as above and then use the following equation:

$$C = \frac{y - 1}{2} x \text{ the capacity of two similar circular plates as above}$$

Q. 3. What is meant by a loading inductance as used in wireless telegraphy?

A. 3. It is simply a coil of wire, usually made with a variable tap-off connection and used for increasing the time period of vibration of an oscillatory system. Connected in series with the antenna it has the effect of increasing the tuned wave length of that circuit. The loading inductance is usually mounted separately from the primary winding, and at a distance from its magnetic field. And additional coil of wire is sometimes connected in series with the secondary winding of a receiving tuner and it is then known as the "secondary loading coil."

Q. 4. How may the wave length of an aerial be obtained?

A. 4. By means of a wavemeter or roughly, by calculation from the dimensions of the aerial.

A complicated formula for the latter method was given by Dr. L. Cohen in the "London Electrician" for February 1913, and another by Prof. Howe in the "Wireless World" December 1914 and January 1915. Simpler rules, though perhaps more approximate, were given in the article by John Vincent in the March issue of this magazine.

Q. 5. What is the wave length of a loose coupler 6 ins. in length with No. 28 wire on the primary and secondary. Which is preferable, No. 28 or No. 32 wire for the secondary?

A. 5. We cannot calculate the wave length of the tuner without more complete dimensions, and a description of the antenna used. For commercial apparatus No. 32 wire is preferred on the secondary.

## Damping in Radio Circuits

H. L. G., Omaha, Neb., asks:

Q. 1. In regard to article on "Damping in Radio Circuits" by John Vincent in your May 1916 issue, I would like to ask whether the effect would be the same when using a heavier bob or weight to increase the period, instead of lengthening the rod or string.

A. 1. It appears that there exists some confusion as to the effect of changing the weight of the pendulum bob. In the ordinary simple pendulum only two things affect the time of swing, and these are the length of the string and the "acceleration of gravity" at the place the pendulum is set up. This latter item is constant for any one place on the earth's surface, and therefore the only way to change the time-period of a simple pendulum is to change the length of its string or rod—unless it is moved to a different locality, which has a different "acceleration of gravity." Adding to or subtracting to the amount of material in the pendulum bob does not change the time of swing, so long as most of the mass is concentrated near the lower end of the system. Your correspondent can prove this very easily, to his own satisfaction, by timing a pendulum consisting of a bucket swung from the ceiling by light, strong cord. The time for a complete period will remain the same when the bucket is filled with water as when it is empty.

If a spring pendulum is used instead of the simple gravitational pendulum consisting of a weight and cord swinging from side to side, the size of the weight will influence the period of vibration. When a weight is hung on a spiral or helical spring, and allowed to vibrate up and down, the vibration will be quicker the lighter the weight and the stiffer the spring.

It will appear from the above that the simple

pendulum can be adjusted to swing with a definite period of one second, or of two seconds, by changing the length of the string or rod, and in that way only.

### Copper-Plating Leyden Jars

D. A. S., Midland Beach, Staten Island, N. Y., writes:

Q. 1. Can you inform me how I may prepare glass in order that the surface may be copper-plated? How can I prevent blistering? I hear much these days of the copper-plated Leyden jar.

A. 1. The process is rather expensive. One manufacturer coats the bare glass with a cold silver solution such as is applied to the rear of mirrors. The jar is then placed in a furnace and heated near to the melting point whereupon the silver is thoroughly burned into the glass. The jar is then allowed to cool slowly and afterward placed in an ordinary electroplating vat and given a heavy coating of copper.

Another manufacturer applies a cold silver solution to the inside of the glass and a coating of graphite held in place by shellac to the outside of the glass. The jar is placed in the electroplating bath without burning.

### Dimensions for Transmitting Transformer

A. W., Fayette, Ala., writes:

Q. 1. Please give me the dimensions of the primary and secondary windings for an oscillation transformer for use with a 1 K.W. transmitting set. Please state the diameter of both windings.

A. 1. It is assumed that you desire an oscillation transformer of the pancake type, and if so, it should have the following dimensions: The primary winding has eight turns of flat copper ribbon placed on an insulating support edgewise, the copper being about  $\frac{1}{2}$  in. in width by  $\frac{1}{16}$  in. in thickness. The outside diameter of the winding is 10 ins. and the inside diameter about  $4\frac{3}{4}$  ins.; the turns are therefore placed about  $\frac{1}{4}$  in. apart. The secondary winding of the oscillation transformer may consist of about 18 turns of the same size ribbon, also spaced  $\frac{1}{4}$  in. apart. The outside diameter of this winding is 14 ins. and the inside diameter about  $4\frac{1}{2}$  ins.

Q. 2. Should the ribbon be wound in the same direction in both windings?

A. 2. It makes no difference which way they are wound.

Q. 3. In the construction of a condenser for a 1 K.W. transformer, should the tinfoil be placed on both sides of the glass plates and the plates then stacked together so that the tinfoil of one plate touches the tinfoil of the other, and should the copper ribbon for making contact with the tinfoil be brought out between the plates, and should the odd number of plates be

connected to the right condenser terminal and the even numbers to the left, or vice versa? Would it be satisfactory to place the tinfoil on a glass plate, then lay on top of it another glass plate, followed by a second sheet of tinfoil, and so on throughout the series until complete?

A. 3. It is preferable to coat both sides with tinfoil and the best method is to place the foil on the glass plates with a good grade of fish glue, after which the plate is shellacked to prevent the foil from blistering. Alternate plates are connected to one terminal, and the intervening plates to the inside terminal. The surfaces of the sheets of tinfoil from each plate should be pressed tight against the sheet next to it. The reason for this is that unless the tinfoil is firmly attached to the plates, a violent brush discharge takes place between the glass and the foil, causing blisters.

Q. 4. What should be the capacity in amperes for a transmitting key to break the primary circuit of a 1-K.W. 110-volt 60-cycle transformer?

A. 4. Owing to phase displacement in the primary circuits an ammeter will indicate from 14 to 16 amperes, but of course with no phase displacement the ammeter should read about  $9\frac{1}{2}$  amperes. The transmitting key should have a current-carrying capacity of 15 amperes.

### Radio Frequency Changers

W. H. H., Cold Spring, N. J., asks:

Q. 1. Will you kindly give me a more complete description of the transformer which doubles the frequency of the current imposed on the primary winding, which you mention in the article entitled "Long Distance Wireless Telegraphy" in the August 1915 issue of this publication.

A. 1. It would be far too long an article to give in this column, but you will find one of the most complete short descriptions of radio frequency changers in print in the March 1915, Volume 3, No. 1 issue of the Proceedings of The Institute of Radio Engineers. This is a 35-page article and it covers not only static but dynamic, electrostatic as well as electromagnetic, frequency changers. It is fully illustrated and contains many graphs showing the relations of the several currents during the frequency changers. If you are at all interested in the subject, we most certainly recommend that you read this article. If you cannot obtain a copy of this publication from a library or member of the Institute you can purchase a copy for \$1 direct from the Institute Secretary, 111 Broadway, New York.

Q. 2. To what degree is the core of the transformer saturated by the direct current?

A. 2. The core is saturated to the point known as the knee of the curve. It is the point where the saturation begins to increase very slowly with increase of magnetizing current.

# For Practical Workers

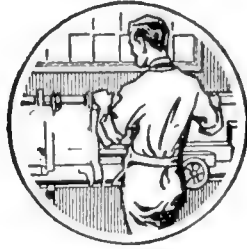

## An Opposed Cylinder Steam Engine

By Ray F. Kuns

**T**HE steam-engine shown in the drawings is one requiring no machine work and is so designed that any ambitious amateur may feel certain of success if he is at all careful in his work.

The base should be worked out to the size shown in Plate 2. If no iron base is at hand the hardwood base shown may be covered with either tin or sheet-brass. If this is done the bottom should be covered as well as the top, and edges and all joints soldered to exclude moisture. If not covered the base should be painted or enameled to prevent it from warping when the steam and hot water strike it.

The cylinder support is shown as C S in Plate 2 and in detail in Plate 3. Work this up out of wood. Next cut out of brass or tin two strips as shown on Plate 3. These are fastened to the wood support with screws. To make a neat job the ends and top of the support may be covered with brass or tin and all joints soldered.

The cylinders are made from 16-gage seamless-drawn brass tubing. This is  $1\frac{1}{2}$  ins. outside diameter and should be entirely smooth and free from blisters on the inside. A piece 6 ins. long will make both cylinders and the eccentric ring, allowing for squaring and cutting. If no tubing is available an old bicycle-pump or automobile-tire pump will furnish the material. After one end of the tubing is squared up the length of the cylinder  $2\frac{1}{2}$  ins. is measured off on it

and carefully marked, after which it is cut at that point with the hack-saw. The end is again squared up with the file and another cylinder marked and cut off, after which the two uneven ends of

the cylinders are filed true and smooth. Two cylinder heads are required, one for each cylinder. These are shown at CH in Plate 2. Use 18-gage brass or heavy sheet-tin, cut  $1\frac{1}{2}$  ins. in diameter and carefully solder in place.

The steam-chest, SC in Plate 2, is a piece of 18-gage seamless-drawn brass

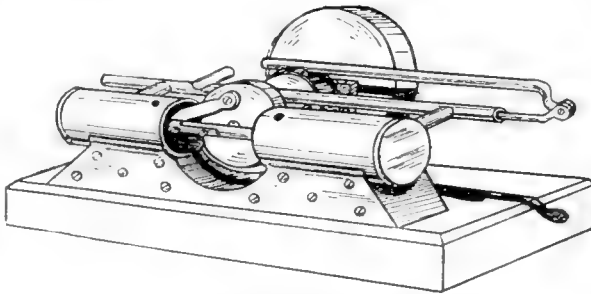

Plate 1. A steam engine having opposed cylinders, which can be constructed by an amateur

tubing  $\frac{1}{2}$  in. outside diameter. This piece will be long enough to give the ports and intake as well as the steam-chest. Cut a piece 8 ins. long for the steam-chest. Square up both ends with a file and remove all burrs from the inside end with the point of a knife-blade. Next measure in from each end of the pipe  $\frac{1}{2}$  in. and drill a  $\frac{1}{4}$ -in. hole at each of these points for the ports. Be sure to drill the holes on the same side of the pipe.

The ports *P* shown in Plate 2 are made from the piece of tubing left from the steam-chest by cutting two pieces each  $\frac{3}{4}$  in. long. File one end of each to fit the steam-chest tube and the other end to fit the cylinder tubing. Solder these pieces to the steam-chest over the holes drilled for the ports. A  $\frac{1}{4}$ -in. hole is next drilled  $\frac{1}{4}$  in. from the cylinder heads in each of the cylinders, after which they are temporarily fastened in position on the cylinder support with these holes on top. Next solder the other end of the port pipes to the cylinders. Remove all burrs from the inside of the steam-chest and cylinders with file, emery-paper or knife-blade.

The slide valve-rod is made from a piece of  $\frac{1}{4}$  in. brass rod 9 ins. long. It is first bent to the shape and flattened on the end as shown, SVR in Plate 2. Next file two notches around the rod. These are about  $\frac{1}{4}$  in. wide and not quite  $\frac{1}{16}$  in. deep. The center of the first one is located  $1\frac{1}{4}$  ins. from the center of the  $\frac{3}{16}$ -in. hole, which is drilled in the flattened end for the bolt. The center of the other one is made exactly 7 ins. from the first one. Be careful to get these properly located as it is the most important part of the engine.

The slide valves are cast on the slide valve-rod just described. Use babbitt

metal for this. A piece of the  $\frac{1}{2}$ -in. tubing  $\frac{3}{8}$  in. long is first worked out and all burrs removed from the inside. A  $\frac{1}{2}$ -in. hole is bored in a board  $\frac{3}{8}$  inch. deep. In the center of this hole the  $\frac{1}{4}$ -in. bit is placed and the hole bored on through the board. Now place the small piece of pipe in the  $\frac{1}{2}$ -in. hole and slip the valve-rod into the  $\frac{1}{4}$ -in. hole, passing it down until the first notch is in the center of the pipe. The valve may be cast by running the pipe full of babbitt. Carefully remove from the mold and set it up for the other valve, using the same piece of pipe. When both valves are cast in place they are carefully fitted into position in the steam-chest. If they are found to fit too tight they may be scraped very lightly with a knife.

From the piece of  $1\frac{1}{2}$ -in. pipe left from the cylinders make the eccentric ring. This is made just  $\frac{1}{2}$  in. wide. After it has been carefully worked into form and the edges rounded a trifle on the inside as well as out it must be used to cast the eccentric and piston-heads.

The small piece of pipe is then fitted and soldered to it, as shown in Plate 3.

The purpose of the eccentric is to throw the valves first to one side of the ports and then to the other. The eccentric mold shown in Plate 3 is used to produce the casting for the eccentric. In making the mold the expansive bit is used to bore a hole  $\frac{1}{2}$  in. deep in a block of wood. This hole should permit the eccentric ring to come into it evenly. After this hole has been smoothed the  $\frac{3}{8}$ -in. hole mentioned above is bored as well as

one on the other side of the center for pouring the metal.

Prepare the mold for pouring by installing the brass ring. After turning the open face of the mold down on a piece of paper laid on the bench and squaring up the piece of  $\frac{3}{8}$  in. steel, the mold may be poured.

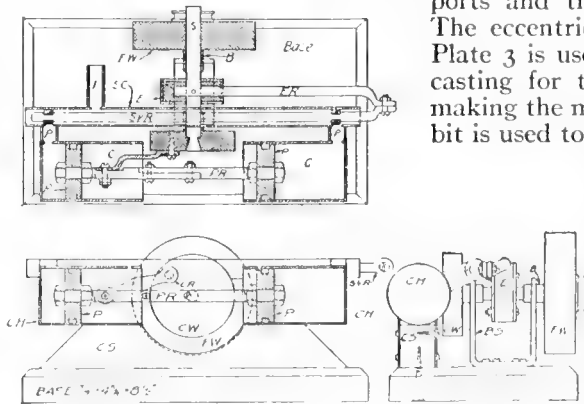

Plate 2. Construction details of the slide valves



The piston-heads may be cast in the eccentric ring. Simply lay the ring on a piece of paper on a flat surface and pour it full of babbitt. Two of these are required. After casting, the center is carefully

located with a pair of dividers, after which a  $\frac{5}{16}$ -in. hole is drilled through it. To cut the groove in the piston-heads the arrangement shown on this page is used. A block of wood has a  $\frac{5}{16}$ -in. hole bored through it. A piece of  $\frac{5}{16}$  in. iron is threaded on one end and a piston held in place on it by means of locked nuts. The other end of the iron is run through the block and bent into the form of a crank.

Drive a nail into the block for the  $\frac{1}{4}$ -in. chisel and the groove is cut by turning the piston and holding the chisel against it. The grooves are cut  $\frac{1}{4}$  in. deep.

The piston-rods are worked out from cold rolled steel or brass. Only the one needs the  $\frac{5}{8}$ -in. notch cut into it as that is for the connecting rod to fit into. The two inner ends of the piston-rods are lapped together and bolted with two  $\frac{1}{8}$  in. by  $\frac{1}{2}$  in. stove bolts. A  $\frac{1}{8}$ -in. hole must also be drilled in the center of the space allowed for fastening the connecting rod. The pistons are held on the ends of the connecting rods by means of locked nuts. Note Plate 2.

The connecting rod is shown in Plates 2 and 3. Use  $\frac{1}{8}$  in. by  $\frac{1}{2}$  in. material, either brass or iron. The curves may be worked out with a file.

The crank wheel is  $\frac{1}{2}$  in. thick by 2 ins. in diameter. The mold is made as

was the eccentric mold, except that no ring is used and the hole for the shaft is in the center. A hole must be provided for pouring. When pouring, be certain to have the shaft set square with the mold. Square up by the method suggested in the drawing.

The fly-wheel is made of lead or babbitt. In this case the mold is about  $3\frac{1}{4}$  in. deep and 3 ins. in diameter. The shaft should be in the mold when the casting is made.

The bearing support is easily made of either iron or brass. Bend to shape first and then lay off and drill the holes for the bearings. These are short pieces of pipe used for the steam-

chest, ports, etc. Place the shaft through the bearings, and place the bearings in place in the support, when they may be soldered in position.

The shaft is shown in Plate 3. It is best made from cold rolled steel although brass will do.

Having brought all of the details to this point the most interesting part is now to be done.

In assembling, fasten the connecting rod in position on the piston-rod. Use a  $\frac{1}{8}$ -in. rivet for this, but do not make it too tight. Pack the pistons with cotton waste, asbestos packing or soft yarn. Assemble them in position in the cylinders, bolt them together and see that they work smoothly. Next place the shaft in position in the bearings with the eccentric and eccentric ring in place. Fasten the eccentric to the shaft by drilling a small hole down through both

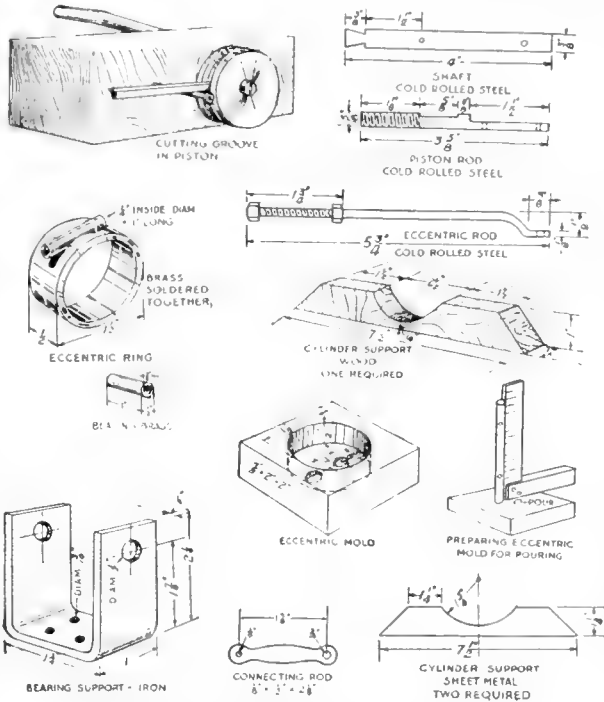

Plate 3. Diagrams showing dimensions of the various parts of the opposed cylinder steam engine

of them and inserting a wire pin. The eccentric is placed midway between the bearings. The ring is slipped on the eccentric and the guide plates bolted fast. The fly-wheel is assembled on the outside of the bearing and pinned on the same way.

Place the bearing support with its assembled parts in position on the base. Try the connecting rod to be certain it will connect properly, and mark the points for drilling holes in the base. These want to go all the way through. Battery or stove bolts are inserted from the bottom and the support is bolted down.

Since the connecting rod will have to lead the eccentric by a quarter turn the heavy side of the eccentric will need to be turned until it is on the back of the engine, or on the side with the inlet, when the position of the connecting rod end may be marked on the fly-wheel. This will be  $\frac{3}{4}$  in. directly above the center of the shaft. A  $\frac{3}{8}$ -in. hole is drilled at that point and a head screw  $1\frac{1}{4}$  in. fastens the connecting rod in position.

Next assemble the slide valve in position as well as the eccentric rod. These are bolted together on the outer end. Adjust the eccentric rod until the valves just cover the ports. When this is done lock it in place by means of the adjusting nuts. When all parts appear in their proper positions the cylinder may be permanently fastened in position by soldering them to the sheet-metal supports. Power for the engine may be secured from a boiler or radiator.

### A Pulley Made from Wax and Wire

**A** PULLEY for a small motor or other piece of apparatus can be very easily made by drilling a small hole through the shaft where the pulley is to be located. A wire is put through

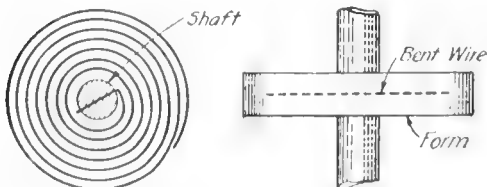

Sealing wax and wire can be made into a light pulley for a small motor

the hole, held tightly, and bent as shown in the cut, making the outer curve a little less than the diameter the finished pulley is to have. The shaft that is to take the pulley is then held vertically, and a form the size of the pulley desired is placed around the coiled wire.

Sealing wax is then poured in and allowed to harden for an hour or two. The coiled wire will hold the sealing wax together, and will be found to be strong enough for light work.

### Making a Space with a Chain Line

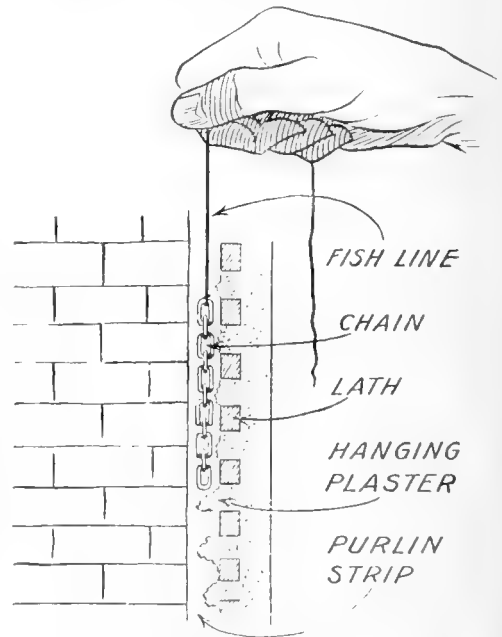

Making an opening for electrical wiring

**A**N electrician was called to do some wiring in a brick house where the plaster was put on lath nailed to a vertical strip fastened to the bricks. In applying the plaster numerous hangers or hooks back of the lath were in the way of the conduit. It was an easy matter to insert the fish wire but how to make a sufficient opening for the conduit puzzled the electrician until a chain was seen in the tool-box.

This was tied to the end of the fish line and worked back and forth by joggling it up and down against the plaster until a large enough opening was produced to let in the conduit without any obstruction.—CHARLES F. SMISOR.

**Straightening Warped Boards**

**W**ARPED boards may be straightened by the following method and they will stay straight. Resaw the board into strips, about 3 ins. wide. Joint all edges and glue the pieces together, being careful to reverse every other piece sidewise. Then plane the surface carefully and the board will not warp again.—L. G. ABELE.

**Sloping a Drawing-Board**

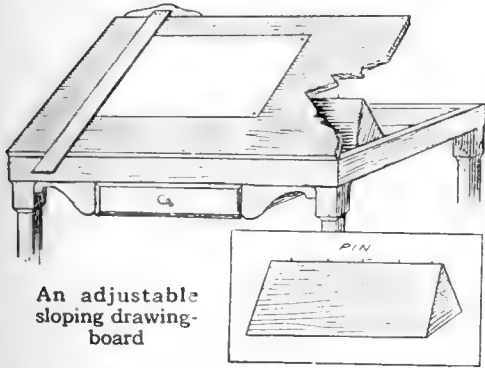

An adjustable sloping drawing-board

**T**HERE is many a mechanic who finds that if his drawing-board were only sloped he could work much better.

The accompanying drawing will explain itself. A block of wood having three or four headless pins driven in the edge will hold the drawing board, the slope being regulated by the position of the block.—ALFRED R. WAGSTAFF.

**Keeping Food Without Ice**

**F**OR the temporary preservation of such food products as rapidly spoil by heat, a modification of the Mexican "Olla" is used with success. The "Olla" is a water jar of porous, unglazed native biscuit work, which has the property of keeping the contained water cool, even in the severe temperatures of the southwestern deserts, when filled and hung in a current of air. Hanging in the sun keeps it cooler. The principle involved is the reduction of temperature due to rapid evaporation, the water which penetrates the clay being rapidly evaporated from the surface of the jar, lowering the temperature of its contents.

This principle is applied by dwellers far from an ice supply, as follows:

A frame of required size is made from a wood with no decided taste or odor. The "cucumber" wood, from which the old-fashioned pump-logs were fashioned, is probably the best. Bass or linden is also used. This frame is covered with copper wire screen cloth, using turned copper tacks for fastenings. This again is covered with two or three thicknesses of cheese-cloth, stretched and tacked. A tin gutter is so made that a properly designed slot in the bottom may be filled with cotton lamp-wicking, which projects in such manner as to touch the cheese-cloth enclosure, to which it is stitched at intervals to insure positive contact. The floor of this arrangement is elevated in such a way as to permit any excess of moisture reaching the cheese-cloth to drip off and run away to waste. By means of a regulating valve the water supply admitted to the upper gutter is just sufficient to keep the cheese-cloth constantly damp. The entire apparatus should be located in a cool passage or a shady porch. In either case a free circulation of air is essential. The evaporation reduces the temperature inside the device to a noticeable degree.

If a pressure source of water supply is available, it may be used. If not, a bucket can be provided with a proper faucet, and furnish the water supply. A collapsible modification of the "Olla" carried by a picnic party will replace the thermos bottle as a means of keeping the liquid refreshments cool.

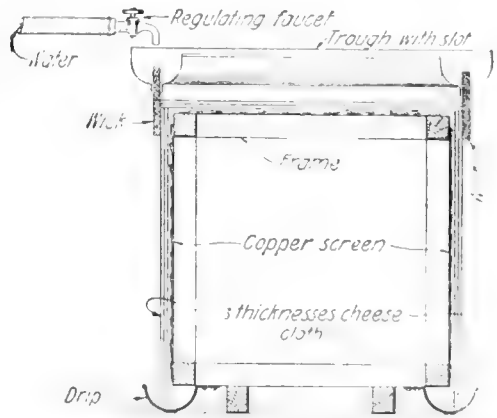

Constant evaporation of water from a strip of cheese-cloth keeps the interior of the box cool in the hottest weather

Jig for Drilling Holes in Peripheries

THE jig shown in the drawing was designed for drilling holes in the periphery of the blanks shown in Fig. 1. The piece *A* is made in the milling machine, the divisions being obtained by means of the dividing head. The blanks are held on the spindle *B* by means of the nut. The plunger holds it in position while the hole is being drilled. The spring prevents vibration from loosening the plunger. The piece *A* can be made with the holes spaced equally or not.—C. ANDERSON.

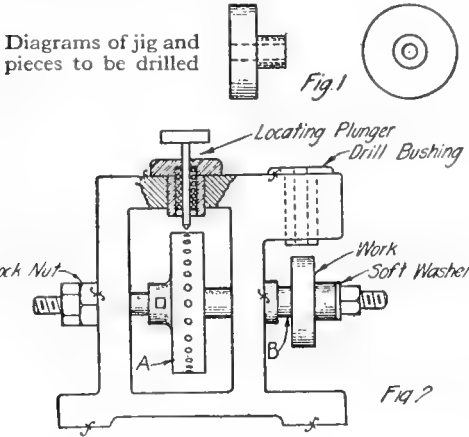

mild steel milled so as to enter the tool-post, which is drilled and tapped on one end to receive the stud with the body turned to fit the hole in the cutters, and milled square or hexagonal on the head for the monkey-wrench.

This holder is cheap to construct and the saving in speed-formed lathe tools by this method amounts to many times its cost.—GEO. P. BREITSCHMID.

A Painless Way of Killing Chickens

CHICKENS may be killed quickly and painlessly in the following manner. Procure a piece of stout cord or rope about five feet long and make a slip noose at one end. Fasten the other end on a pole or the side of a wall so that the noose hangs about three feet from the ground. Put the chicken's legs in the noose and draw it tight. Grasp the chicken's head near the mouth with the left hand (the chicken will open its mouth voluntarily) and with a small sharp-pointed knife, reach into the chicken's mouth over the tongue, to where the head joins on to the neck. By giving a quick jerk with the knife, the jugular vein will be severed. This is a quick and painless way of killing chickens.—JOHN D. MACKNIGHT.

Convex Milling Cutters

AN adaptation of convex milling cutters opens a wide range of either convex or concave cutters for formed work in the lathe.

All that is necessary is a piece of

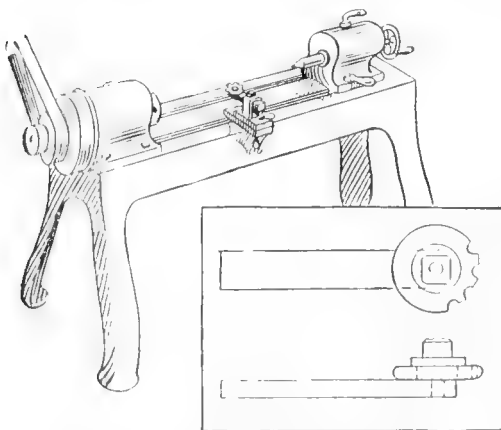

A holder of milled steel for the cutter is a saving in convex milling

Measuring Bucket for Flowing Water

A BUCKET which measures exact quantities of water from a flowing stream is shown in the illustration. The amount measured depends on the size and location of the shaft. A counter is attached to the shaft to register the amount of discharge from the bucket as it tips to turn out the water. The overflow occurs when the water reaches a level that throws the weight off balance so far that it turns the bucket on its bearings and spills the contents, after which it rights itself for another charge.

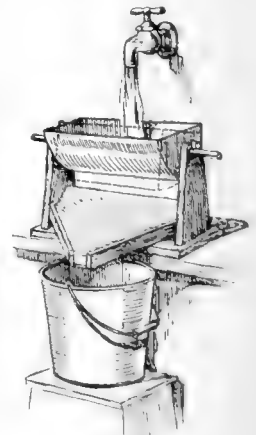

Ingenious device for measuring flowing water

# Making a Bomb Thrower for Sham Battles.

By J. S. Zerbe

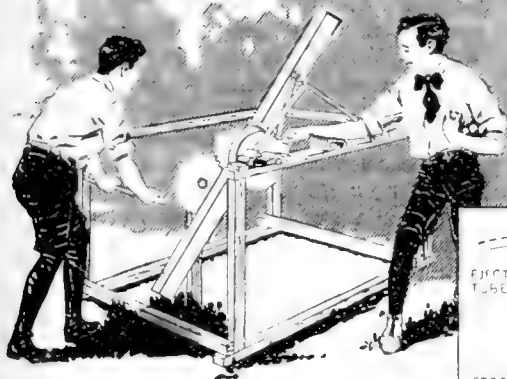

**M**ODERN methods of warfare have developed, among other things, the throwing of hand grenades, or bombs,—projectiles which are used at close quarters against an enemy's trench and also for the purpose of resisting a rush. The use of this weapon does not depend so much on the amount of actual damage which it accomplishes as it does upon the disorganizing results in the ranks of the enemy following the explosion. Many grenades are now provided with chemicals which produce irritating or stupefying gases designed to halt a charge or to silence the activity of a trench about to be stormed.

The disadvantages are the inability of the throwers to propel bombs a sufficient distance to do the most effective work and the inaccuracy of delivering the shots. In action during battle it is difficult to follow up a correctly-put shot with another which will be sure to reach the same spot.

The grenade is a device which can be made for throwing small projectiles, and in such cases the gear-wheel described need not be used, since speed is not so essential. Its use, moreover, will teach important lessons in the trajectory of projectiles.

The device utilizes centrifugal motion

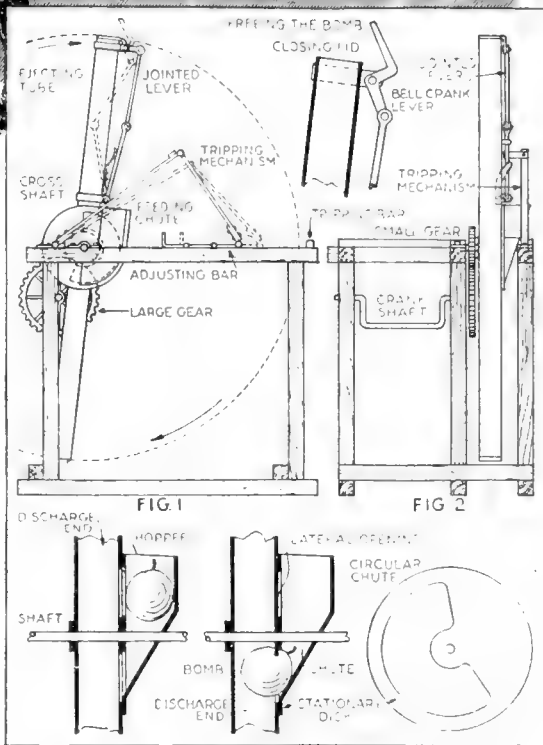

By means of centrifugal force the apparatus shown above throws bombs a surprisingly long distance. With two such machines, boys can wage battle as long as their ammunition holds out

and in this respect resembles the action of the arm in throwing an object. Its use in warfare will effect a wonderful change in the handling of this class of projectiles. The drawings above show a side view, Fig. 1, and a front view, Fig. 2.

A wooden or metallic frame is provided which comprises six posts, a base upon which they are mounted, and three top stringers. Two of these stringers are

mounted close together to receive a cross-shaft which carries a tubular body four inches or more in diameter. This tube is preferably square in cross-section, and the shaft passes through it midway between its ends.

At one side of the tube is a small gear-wheel which meshes with a gear twice the diameter. The latter gear is mounted on the end of a shaft thirty inches long, which has a journal-bearing near the large gear; its other end is journaled to the side of a post. Between the two bearings the shaft is bent to provide a crank so that two men can operate it.

The important features are to load the thrower and release the missiles, both of which functions are provided for by simple mechanical expedients. The loader comprises a lateral opening in the side of the tube, and covering this opening is a stationary disk which has a concentric opening therein which extends half way round. A chute covers this opening, the lower end of the chute being gradually drawn in to the tube, so that when a hand grenade is dropped into the mouth of the chute and the opening reaches the upper end of the concentric opening, the inclined side of the chute will cause the grenade to move toward the throat of the tube and finally drop to the discharge end.

This motion of the grenade takes place while the discharge end of the tube is moving downwardly, and as the tube is in constant motion on its axis the missile swings around one-half of the arc formed by the end of the tube, a distance of nine feet before it reaches the ejecting point.

The ejecting end of the tube has a lid hinged at its side, and a bell-crank lever arm projects out at one side. This arm is connected by means of toggle-jointed levers, one of these being hinged to the tube near its axis. The two levers are connected together by means of a rule-joint hinge, and are of such length that when the lid is closed they are out of line with each other, and thus automatically prevent the lid from opening and discharging the missile in the tube. When the tube reaches a predetermined point the toggle-jointed levers strike a spring finger which causes them to swing back and instantly open the lid,

drawing down the bell-crank lever arm. The result is that the grenade is free to shoot out.

Immediately thereafter the projecting lid reaches a cross-bar on the frame, which swings it back to a closed position, ready for the next missile. To provide a means for regulating the point of discharge the frame is provided with a pair of bars hinged together so as to assume an A-shaped form, the lower end of one bar being hinged to the top stringer, while the lower end of the other bar is hinged to a horizontal arm which rests on the stringer. This bar is provided with a pin so that by moving it back and forth the upper jointed ends of the two bars, where the spring finger is located, will determine the tripping point for releasing the missile.

Two men can easily swing the tube at the rate of ninety revolutions a minute, and assuming that the bomb weighs eight pounds, the unit of force transferred to the grenade is 230, compared with 45, the maximum available when throwing by hand. The advantage of the device is the great accuracy with which the bomb can be thrown. When the speed of the swinging tube is the same the bombs will reach the same area unfaillingly. From fifty to a hundred missiles can be thrown a minute.

### To Compress a Coil-Spring

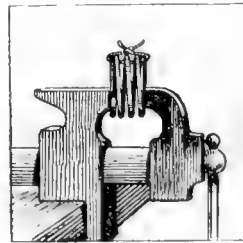

A good way to compress a recalcitrant coil-spring

**S**OMETIMES it is difficult to compress a coil-spring. The spring always seems to fly off at the wrong time. To eliminate this, place the spring in a vise and compress it as far as it will go. Then run a piece of

strong twine through the inside and tie it. The spring is held in a clamp, or if not too strong is held in the fingers, and the part that was tied is placed in the vise and another piece of string tied through the coil. This gives two strong holdings and the spring is then slipped over the shaft.—NORMAN S. McEWEN.

The Whistling Bicycle Wheel

A MOST interesting toy to teach young people the value of harmonic sounds is a device which any boy can make. Fig. 1 of the illustration shows a side view and Fig. 2 is a top or plan view. Small rubber-tired wheels 10 ins.

speed up the wheel so that it rotates rapidly. The harmonic devices are simply tin tubes, each  $\frac{3}{4}$  of an in. in diameter, and 4 ins. long. By means of a file a cross-cut is made so that the opening is  $\frac{1}{2}$  in. across. This cut should be  $\frac{3}{4}$  in. from the closed end.

A tightly-fitting cork  $\frac{1}{4}$  in. long is placed in the end of the tube, and the other end of the tube is provided with a cork designed to move in and out, but tight enough to prevent leakage of air. To this cork a wire loop is attached so that the cork may be drawn out at will and adjusted at the proper place.

The pitch of each whistle thus made depends on the location of the cork within the tube; the nearer it is to the opening the higher will be the pitch. The smaller the tube the more piercing will be the note, so that any number of these whistles may be attached to the rim, some small and others large, thus giving shrill or somber sounds. Instead of tin, papier-maché, brass, or copper tubes may be used. The different materials give what is called the timber tone-color, or quality to the sounds.

These whistles may be tied to the rim of the wheel at various angles with reference to the rim. This will have the effect of imparting peculiar effects to the tones.—J. S. ZERBE.

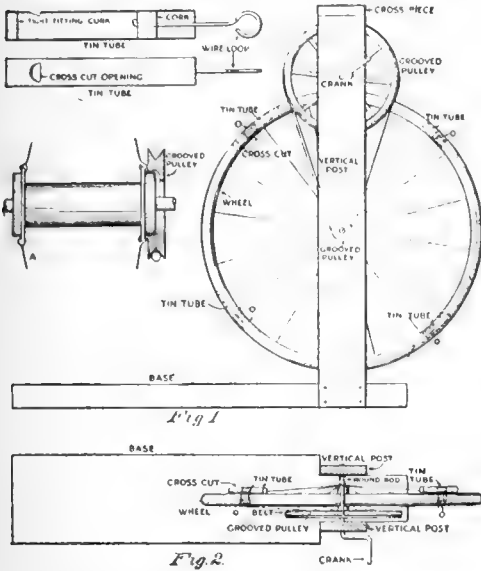

The various parts employed in the construction of the musical wheel are here shown in side and plan views

or more in diameter are purchased at any supply house, and are mounted on ball-bearing spindles ready to be attached to a frame. In this description a wheel 12 ins. in diameter is used.

The frame comprises a base preferably 2 ins. thick, 5 ins. wide, and 33 ins. long. Near one end is a pair of vertical posts secured at their lower ends to this base, and they extend upwardly 33 ins., each being made of  $\frac{1}{4}$  in. material. The upper ends are held in alinement by a cross-piece. A grooved pulley, about 2 ins. in diameter, is fastened to the hub of the wheel at one end, which can be done easily by a pair of bolts. The other grooved pulley, 8 or 10 ins. in diameter (such as is used on sewing-machines) is mounted directly above the small pulley on a round rod, one end of this rod being bent to form a crank. A common sewing-machine belt is placed on these two pulleys.

This arrangement enables the user to

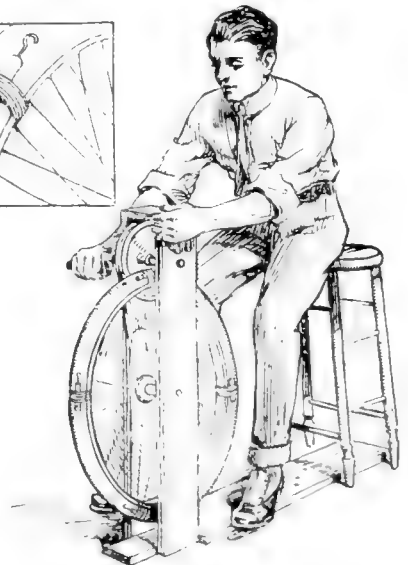
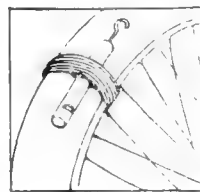

A wide range of musical tones can be produced with this home-made outfit



Hoisting Timbers Rapidly

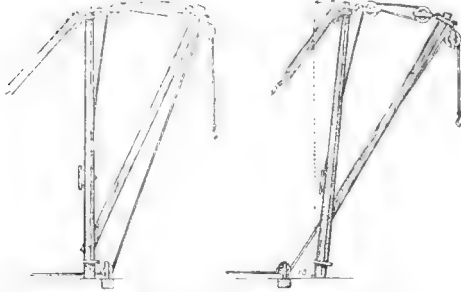

At the left is shown the usual way of hoisting logs. At the right may be seen a new arrangement which saves power

SEVERAL thousand cedar poles can be removed from a river and deposited on flat cars alongside by means of an ordinary "stiff-leg" derrick with a hinged boom. Instead of setting the mast vertical, the top should be inclined about 18 ins. toward the river, its height being about 50 ft.

Instead of attaching the snatch-block for the hoisting cable to the foot of the mast, anchor it about 18 ins. from the foot of the mast, on the land side. In this way the boom is swung around by the cable when the load is lifted, and when the load is dropped the leaning mast causes the empty boom to return over the water, thus making it automatic each way through 180 degrees. By the observance of such a simple expedient as tilting the mast, a great deal of labor is saved.—J. L. BAYLEY.

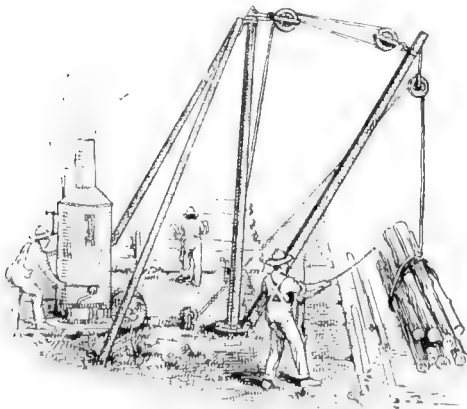

With this newly arranged derrick large quantities of logs can be raised from a river and deposited on flat cars in a short time

An Adjustable Tap Wrench



A serviceable wrench

ONE of the best tap wrenches to be had can be made in a few minutes by anyone following these directions:

Cut a piece of  $\frac{3}{8}$ -inch sq. tool steel 10 ins. long, exactly in the middle, leaving two 5-inch pieces. Lay these pieces over each other a distance of  $1\frac{1}{2}$  ins.; clamp the lapped ends in a vise and  $\frac{3}{8}$  in. from each end of the lap, drill a No. 8 hole through the lap. In one piece tap the holes with a 14-24 tap, and re-drill the holes in the other piece with a  $\frac{1}{4}$ -inch drill. Use two 14-24 cap screws 1 in. long, and file the threads off a distance of  $\frac{3}{8}$  in. from the head. Put your two pieces together and mark off the exact center of the lap, then file a V-shaped slot 3-32 in. deep in each piece, to hold the tap.

Round off the handles with a file and emery cloth and, if desired, the wrench may be hardened to a blue steel finish. This wrench will take anything up to a  $\frac{1}{2}$ -inch tap. For a larger and stronger wrench, use heavier stock and longer handles.—L. E. FETTER.

Three Oil-Proof Lutes

ONE of the best known oil-proof lutes contains the following ingredients: Good glue . . . . . 2 parts by weight Glycerine . . . . . 1 part by weight Water . . . . . 7 parts by weight First soften the glue with the water; then melt and add the glycerine. This is a good lute for rendering corks vacuum-tight, and for stopping small leaks of almost anything except water and steam.

A lute suitable for use in laboratories and plants handling oil vapors is a putty made of molasses and flour.

Another useful and very satisfactory oil-proof lute contains the following substances:

- Glycerine . . . . . 90 parts by volume
  - Water . . . . . 10 parts by volume
- These ingredients are to be made into a stiff putty with the following:
- Litharge . . . . . 90 parts by weight
  - Red lead . . . . . 10 parts by weight

This mixture takes several hours to stiffen and about a day to set.

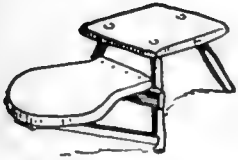

A stool with a board to hold the milk-pail

**A Simple Home-Made Milking-Stool**

THE illustration shows a very easily-made milking-stool, which requires merely a few boards and some sticks. The sticks are used for the legs. Half way from the seat of the stool to the floor, a board is nailed, running parallel to the floor. This supports the board which holds the milk-pail. The pail board is held in place by two braces on the bottom of the legs. A board is then needed under the legs for holding the bottom of the braces. This is a satisfactory and practical article for the farm boy to make.

**Make Your Own Lazy-Betty**

A LAZY-BETTY is a revolving affair placed in the center of the dining table to facilitate service when no maid is employed. The ones which are purchased are usually circular. Here is how one was made:

The top was an octagon 20 ins. across the diagonal. One of the unused extra leaves of the dining table furnished the material. The table was 54 ins. in diameter, and the extra leaf was thus 12 ins. wide by 54 ins. long, furnishing ample material. The base was a similar octagon, 10 ins. on the diagonal. A simple cast brass socket with steel stud furnished the connecting link.

The octagon is a figure of eight equal sides. By laying out a circle 20 ins. in diameter, drawing two diameters at right angles, and bisecting these angles again, the points are found. A similar procedure with a 10-in. circle lays out the base. The edges were carefully jointed with a fine-set plane. Then saw cuts were made as follows: 1-2-3-4-5, to produce the two pieces for the top. The cuts for the base are obvious. The top was fitted, and when contact was secured, it was glued and clamped.

Two stout cleats were nailed on an old table top about 24 ins. apart. Two sets of wedges were made, the matched joint was coated with glue, a piece of paper was laid on the table so the glue

would not stick, and the top was wedged up, as shown. A heavy weight was placed on it to prevent buckling and the job was set aside for 48 hours.

In the meantime the base was cut out and furnished, a small hole, 1/16 in., drilled on its center, and the castings for the turntable were taken in hand.

The steel pin fitting the tapers was turned true and fitted to the upper casting and pinned. The lower casting

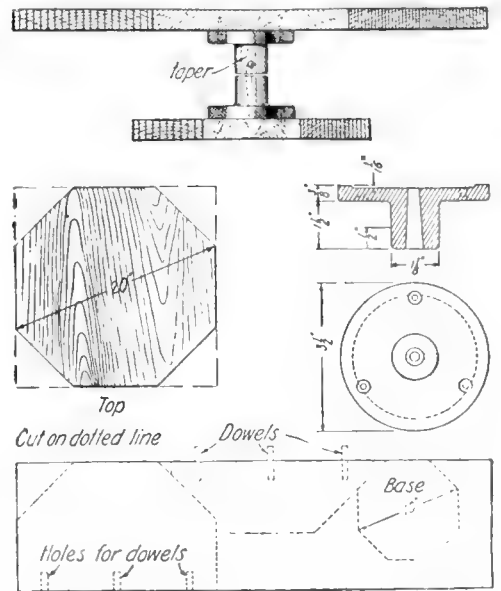

Constructional details of the self-server. The board holding the dishes is mounted on a revolving pin in the center of the table

was ground with powdered emery on to the steel pin until it turned as smooth as glass, and the two castings almost touched. Three holes for flat head brass screws were drilled in each casting and countersunk. A manila paper washer dipped in oil and coated with a graphitic compound was placed to prevent the taper pin from seizing in the lower bearing, and the castings were screwed to the top and bottom octagons, carefully centered. This was accomplished by means of the small hole previously drilled in the center of both top and bottom, the screw holes being laid out exactly with dividers both on the wood and the castings. The newly-cut edges were then dyed and waxed to agree with the finish of the table and the job was complete.

## Replacing Pistons By Simple Means

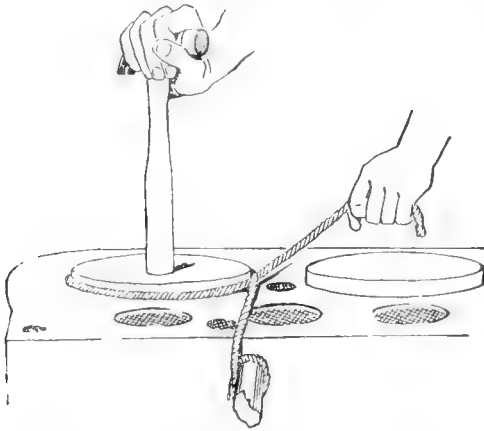

The task of inserting an automobile piston in its cylinder is quickly accomplished with a rope and a hammer

**A**UTOMOBILISTS who have had difficulty in getting their pistons back into the cylinders can accomplish the task with ease with a piece of twine and a hammer-handle. The piston-rings being assembled on the piston with the break in the rings spaced equally around the piston, the piston is slipped into the cylinder and pressed inwardly until the first ring engages with the end of the cylinder, checking its further progress.

A piece of twine is then tied to some convenient projection so that it may be drawn close across the end of the cylinder, and it is then wrapped around the piston-ring one turn, and the loose end drawn taut until the ring is compressed to the desired degree. The piston is then struck with the butt end of a hammer-handle, causing it to slip inward, carrying the compression ring into the cylinder, where it will be held. The operation is then repeated with the other rings.

## Universal Bench-Stop

**A** BENCH-STOP that will hold anything and everything a stop could ever be used for; that will hold work from three-eighths of an inch square up to heavy slabs of wood up to twelve inches wide and three and four or more inches thick, edgewise or laid flat; and that will hold any and all of this work

perfectly square and without injuring edges and corners and yet hold it in a vise-grip, can be made in less than an hour from a few scraps of inch-board, as follows:

Take two pieces of inch-board  $2\frac{1}{2}$  inches wide and 12 inches long and nail them perfectly parallel, planed edges facing each other, to the head of the workbench. Keep them eight, ten, twelve, or more inches away from the edge of the bench, according to the extreme width of the work you plan to use the stop for. Then make another piece of the same thickness, but 18 inches long, and fit it so it will slide snugly between the two pieces. In the center of this piece bore a number of  $\frac{1}{4}$ -inch holes,  $\frac{1}{2}$  inch apart and  $\frac{1}{2}$  inch from the edge, and bore a couple of corresponding holes through the top of the bench, so that a large spike can be inserted and hold the piece in place. Nail a couple of strips crossways on to the two stationary pieces so this sliding piece cannot jump out.

Anywhere from six to twelve inches away from and opposite, and at right angles to it, nail one-half of a wedge made of tongue-and-groove inch-board, groove in, and let it engage with another wedge having a tongue.

A moderate pressure with the thumb against the movable wedge will hold the work in a bull-dog grip and without

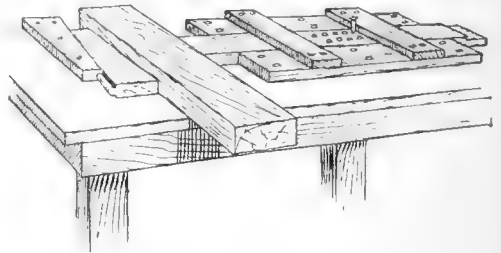

A bench-stop that can be quickly adapted to every kind of work

injury, provided sufficient care has been taken to make the edge of the wedge and the end of the slide perfectly square.

By cutting down one end of the slide to a thickness of  $\frac{3}{8}$  inch and inserting a piece of  $\frac{3}{8}$ -inch board between the wedge and the work, thin boards and strips down to that thickness can be held and planed.

**Chick Mash Box**

A SHOE, candy, or any cardboard box is all one needs to make a chick mash box that is handy and sanitary, and when dirty can easily be replaced. Cut U-shaped openings in the sides and ends of the box, fill with dry mash and replace the cover. The chicks get at the mash through openings, but cannot get into it. A more durable box can be made of wood—L. E. FETTER.

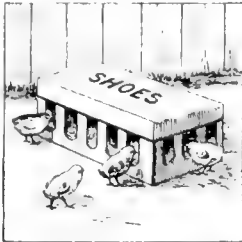

The simplest kind of cafeteria

**Tightening Wire on Knobs**

WHEN using split knobs on open wiring it is sometimes quite difficult to get the wires taut so as to have a presentable appearance.

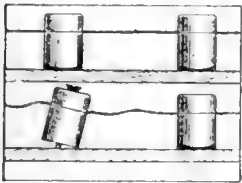

A new way to tighten wires

One method of overcoming this is to start the screw with the knob on a slight angle so that when the screw is tightened up it tends to grip

the wire and pulls it tight—LOUIS LIND.

**Improving a Towel-Roller**

AN ordinary towel-roller has no rim or flange to keep the towel from getting caught between the rod and the end-supports. Cut two semi-circular pieces of cardboard, as shown in the illustration. Cut a hole in each at the proper point to bring the straight edge of the cardboard tight against the back of the roller. Fit the pieces of cardboard on the ends of the roller. The towel will not catch in the ends

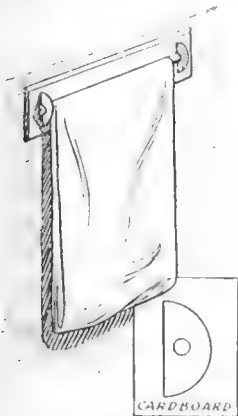

The towel will not catch in the ends

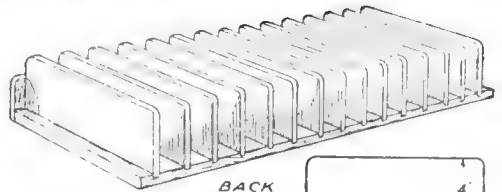

PARTITION

BACK BOARD

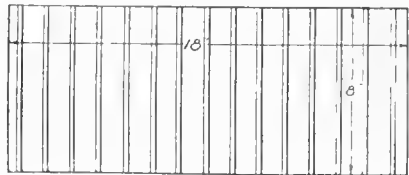
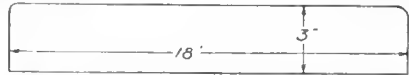
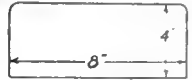

BASE

The numerous slots can be used for salesman's data, each man having a division

**A Manager's Desk File**

A DESK file for managers, which obviates the unnecessary handling of salesman's data, is shown in the sketch. It consists of a board for a base into which a number of slots are cut to receive division boards in an upright position. The base in this instance is 18 ins. long, 8 ins. wide and  $\frac{1}{8}$  in. thick, cut and finished from a piece of quarter-sawed oak to match the flat-top desk on which it is placed. The surface of the board is laid off in divisions of 1 in., allowing  $\frac{1}{4}$  in. for the grooves.

The  $\frac{1}{4}$ -in. boards forming the division partitions are rounded on both upper corners, and they are cut as long as the base is wide. A back board, cut as long as the base, is fastened to its rear edge to prevent papers from being pushed entirely through the file.

The division boards are cut to fit the grooves snugly, so that one may be removed, if desired, to make a wide space for any special purpose. Of course these can be glued in solidly. Domes are driven into the under side to prevent scratching the surface of the desk.

On the front edge of the baseboard are placed the names of the salesmen, and any matter requiring their attention is slipped into the proper place. This handy little device serves its purpose well in this instance.

**Drilling Square Holes**

THE drawings relate to work that is drilled in the lathe. The same piece is shown in Figs. 1, 2 and 3, Figs. 1 and 2 showing round and square holes. They are the formers and are used for drilling square holes in round stock, such as would be used for socket-wrenches, etc. Let us say we need an inch-square hole. The stock is put in the lathe chuck and drilled with a one-inch round drill. Then the former (Figs. 1, 2, 3) is slipped over the stock and fastened with the set screw, *C*. This brings the one-inch square, *B*, against the one-inch round drilled hole. The tool, Fig. 5, is then inserted in the back-center of the lathe and fed to the round hole, the three-sided drill, *D*, cutting the hole one inch square.

This is caused by the square in the former going around the drill, and the drill having a play in all directions.

The play of the drill is provided for by the simple means of something like a modified universal joint, *E* and *F*, Figs. 4 and 5, the pin *E* fitting loosely in part *F*. Being rounded, the part *F* has a movement that works two ways and the pin *E* makes the other two movements. Hence we see that this provides for a limited circular movement.

If the work (flat stock or otherwise) is

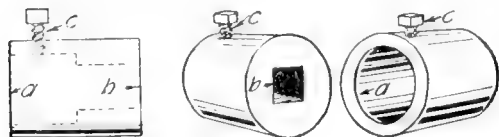

Fig. 1 Fig. 2 Fig. 3  
Formers for round stock that is held in lathe chuck

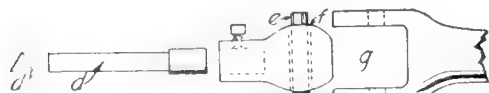

Fig. 4. Drill holder and three-sided drill held in back center

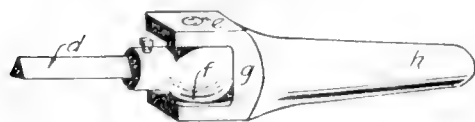

Fig. 5. Same as Fig. 4, but assembled

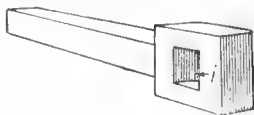

Fig. 6. Former, to be held in tool post of lathe when drill is running and work is on back center

needed to be drilled, the tool (Fig. 4) is inserted in the lathe head, and the tool (Fig. 5) is used in the tool post, the former part *I* being brought up to the work, which is secured by any ordinary means to the back-center. The position of the drill in cutting square hole is shown in Figs. 7 and 8. It must be understood that the former must be as close to the work as possible. The former

should be hardened and the drill edges slightly rounded.

The cutting end of the drill should be slightly rounded, similar to a reamer

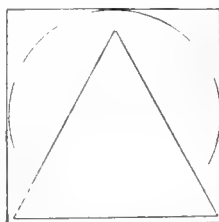

Fig. 7

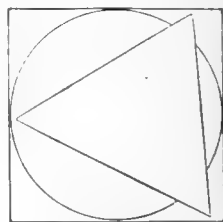

Fig. 8

Showing two positions of three-sided drill about to cut the round hole square

edge. Of course the drill has not much work to do—simply taking out the round corners. It can be used in the drill press, the work and former being strapped to the table.—EDGAR HOLDCROFT.

**A Remedy for Jarring Bottles**

IN order to keep bottles from jarring off a lathe or shelf on the lathe or from being knocked off a shelf which may be remote from the lathe, a tin can is nailed down to the shelf and about 1½ ins. of shavings and sawdust placed in it to keep the bottle from being broken when dropped into it.

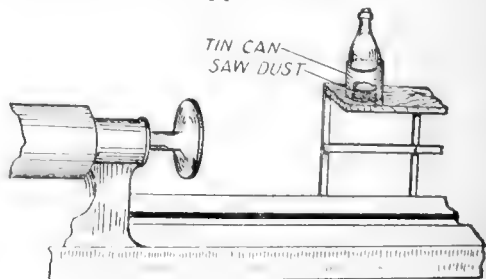

The bottle can not slide or jar off

# How to make a • SLEEPING HAMMOCK

By H. S. Tallman

THE ordinary hammock is no good to sleep in. A special fitting called a spreader improves it, but not enough for real rest. To sleep in absolute comfort, the hammock must support the sleeper without sag. The hammock described does this.

Make a frame of  $\frac{7}{8}$  in. by  $2\frac{1}{2}$  ins. hardwood bars. It should be at least 5 ft. 6 ins. long and 2 ft. 6 ins. wide over the side bars. The end bars are placed on top of the side bars, all of them being laid flat. Bore each junction for a  $\frac{3}{8}$ -in. carriage bolt, and make a fit, but don't put together yet. Cut two braces as shown in cross-section and fit these with  $\frac{3}{8}$  in. carriage bolts. Bore  $\frac{1}{2}$  in. holes as shown in the side bars, and chamfer both sides of the holes, otherwise they might cut the lashings. These holes should be 1 in. from the outer edge of the side bars.

Cut two hanger strips of awning duck, 30 ins. wide and 3 ft. long. Sew these at one end so as to form a pocket into which a  $2\frac{1}{2}$ -in. by  $\frac{7}{8}$  in. spreader bar, 30 ins. long can be slipped. See Fig. 3. Hem the vertical edges if necessary. It is preferable to have no hems on these edges. Tack the other end to the end bar as shown in detail, Fig. 3, and take a full wrap so that the strained portion of the hanger covers the tacks. Nick the duck at the bolt holes with a pocket-knife, put in place on the side bars, and bolt together securely.

Four  $\frac{1}{2}$  in. holes are bored in the spreader bar as shown in Fig. 3. The canvas or duck must be cut out opposite these holes, and buttonhole stitched, to permit threading the  $\frac{5}{16}$ -in. hanger cord. Make a strong knot on one end of the cord, and thread it through the

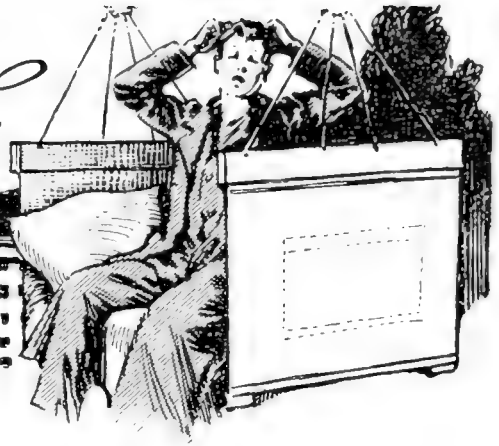

end hole, then through the ring, then the next hole, etc., finishing up with another knot at the last hole. Work the cords and ring until the cords are strained evenly, and lash them firmly together just under the ring.

Pockets of the duck can be sewed to the hanger at one end, for handkerchief, fan, flashlight, etc., if desired. The back curtain is 5 ft. 6 ins. long, and has a heading to pass over a 2-in. by  $\frac{5}{8}$  in. strip which supports it. Holes in the end of this strip permit tying it to eyelets in the back edge of the hanger. The curtain itself is tied with tape to the hangers and side bar as shown in Fig. 3. This prevents to a great measure, direct draft across the sleeper.

The hammock frame can now be hung by stout ropes or chains from screw-eyes properly placed in the framing of the porch ceiling. They must be so placed that the end hangers are vertical or nearly so.

The stretcher is made of heavy canvas. For a person of average weight, the awning duck might be made to serve, but a heavier grade is preferable. It should be 30 ins. wide, and have a 2-in. hem stitched down with at least two rows of stitching, all the way around. In this doubled material the eyes for lashing are cut and buttonholed with strong cotton twine. They should be located as shown in Fig. 1.

A lashing is then taken with the  $\frac{5}{16}$ -in. cotton cord at each hole in the side bar, five in each bar, and pulled tight, tying the knot so as to be underneath the side bar. The end lashings

are served continuously, reefing round and round the end bar, and tucking the final end under the last loop as shown. This permits of tightening the end tension when necessary. The canvas stretcher must be stout enough to stand

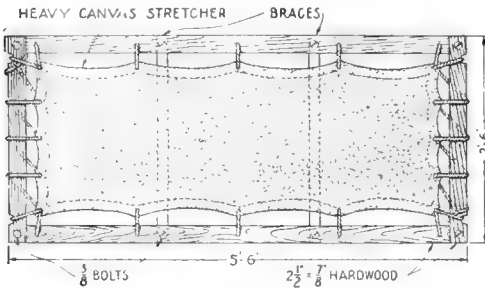

Fig. 1. Diagram showing how the heavy canvas seat is constructed

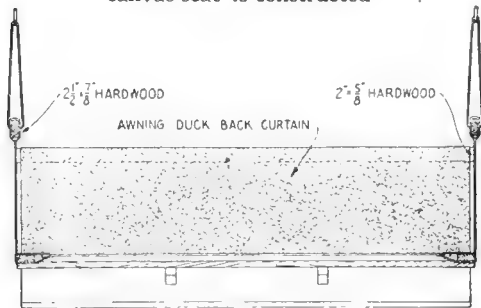

Fig. 2. View of the back, showing the manner of attaching the curtain

for all the purchase a strong man can put on these end lashings. This stretcher takes the place of the ordinary bed spring used indoors.

A mattress about 3 ins. thick is used on this hammock. It can be purchased to fit, or can be made from such materials as common packing excelsior with about 1 in. thickness of common cotton bats on top. It should be well filled and tufted by sewing through and through with heavy twine and an upholsterer's needle, about 8 ins. apart, 3 ins. from the edges, and 8 ins. apart both ways at other points until fully secured. Spanish moss, curled hair or cotton felt can be used if desired. The mattress should be full 30 ins. wide and 5 ft. 6 ins. long.

In hanging this hammock on an open porch, the back curtain should be hung outward to prevent accidental inspection of the sleeper from the open. If used

on an enclosed porch, like that described in the June issue, it is delightful at night, and forms a splendid lounging place during the daylight hours. With properly placed porch awnings, which can be lowered into position, sleeping on the porch, even on a rainy night, is quite possible and entirely comfortable.

Hammocks similar to this in many respects, provided with steel springs and mattress, can be purchased in the market. They are rather expensive, due to their liability to deteriorate from exposure in a damp atmosphere. In an emergency, or a very severe storm, it is only necessary to carry the mattress of this hammock to a sheltered place. The rest of the outfit will not suffer from a drenching, and will dry out quickly as soon as the weather clears. Having once tasted the delight of open air sleep, it will be a matter of regret when the advent of winter compels a change to indoors.

The entire hammock equipment can be taken apart and carried by campers. Its weight is not prohibitive providing the campers have a wagon. In a country where trails take the place of roads and packing horses the place of wagons the hammock could not be utilized. Under such conditions it would indeed be a luxury.

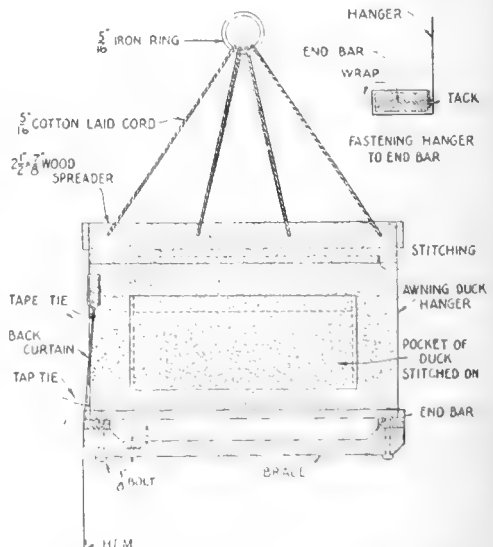

Fig. 3. One end of the swing. Note the strong under-brace and end bar



Determining Brake Horsepower

**T**HE brake horsepower of an engine or motor is often determined by means of a friction or proney brake. Make two wooden blocks *A* and *B* to fit the face of the pulley on the machine to be tested. The pieces *C* and *D* are fastened to the two blocks and the whole clamped together by means of the two bolts *E* and *F* with the nuts *G* and *H* to tighten or loosen the whole. The end of the arm *D* has an iron eye in it to hook to the spring balance *J* which is hung from some suitable support. When the pulley is revolving in the direction indicated at its best speed the nuts *G* and *H* are gradually tightened until the friction is increased on the pulley and the arm pulls downward with considerable force. This tendency to turn will be indicated upon the spring balance.

The net pull at the balance is obtained by subtracting the net stationary weight of the arm from the indicated weight at the balance when the test is made. This distance is represented as *N*. The correct speed of the pulley or revolutions per minute must also be known. After all this data has been obtained the brake horsepower of the machine can be calculated by the following formula:

$$\text{Brake Horsepower: } \frac{2 - N W \text{ RPM}}{33,000}$$

— . 3.1416

*N*. Length of arm in feet.

*W*. Net pull, in pounds, at the spring balance.

RPM. Pulley speed.

This method, simple as it is, will be found of great service in determining, accurately, the brake horsepower of a motor or engine.—B. F. DASHIELL.

The brake horsepower of a motor can be accurately measured by means of a simple apparatus such as the one here shown

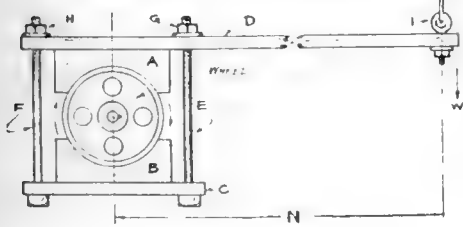

Preventing Carriage Bolts from Turning

**C**ARRIAGE bolts are generally used in fastening sheet-metal parts such as dust-aprons, mud-guards, etc., to automobile running-boards. While these

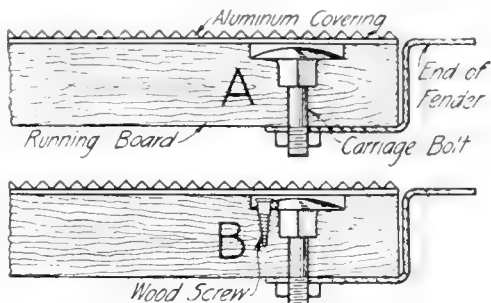

An ordinary wood-screw will prevent bolts from loosening and turning

have a square shank to prevent them from turning in the wood, if the running-board is of soft material the bolts are liable to cut away the wood surrounding the square shank and make it difficult to either remove or apply the nut. This is not a serious matter if the bolt head is exposed so it can be held by wedging, or if it has been provided with a screw-driver slot before assembling. When the running-board is covered with linoleum, which is nearly always shellacked in place, or aluminum matting, which is held by small screws and binding-strips, it is difficult to get at the bolt head. The usual installation, shown at *A*, can be improved materially by following the scheme shown at *B*. This can also be used if the bolt has been installed and the square shank has turned. A 1/8-in. or 5/32-in. drill hole is made in the bolt head and a suitable wood-screw inserted and firmly set into the wood, as at *B*. This is insurance against the head turning and prevents an upward movement of the bolt when an attempt is made to screw on the nut.—VICTOR W. PAGÉ.

A Celluloid Flashlight

**W**HEN a ruby light is not available for developing photographic prints an ordinary flashlight will serve the purpose. Remove the lens and fit a disk of red celluloid in its place. Turn on the light and the celluloid will redden it, protecting the negatives from direct light.—C. H. MILLER.

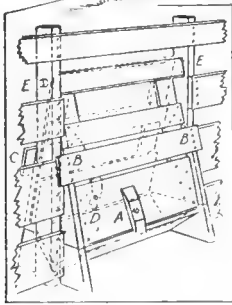

The food can be placed in the trough without the annoying interference of impatient hogs

### Improving the Hog's Table Manners

**M**ORE attention is given to the care and feeding of hogs than ever before, but while the composition of the rations has been improved, there has been no breed of hogs developed even among the aristocratic prize winners, whose table manners are essentially different from those of the plebeian.

If the hogs could not reach the trough until the food had been poured into it and evenly distributed, the feeding process would be simplified. This may be accomplished by applying the method suggested by the accompanying illustration, in which it will be seen that a section of the fence is cut out to receive the trough and gate. The latter, swinging from the top at *E*, is held at the inside edge of the trough by the button *D*, as indicated by the dotted lines, which permits the feed to be poured into it.

The bottom of the gate may then be swung outward and held in place at the outer edge of the trough by the button at *A*, as shown by the full lines, which will allow the hogs to reach their feed.

The stops *B*, *B*, upon the outside of the fence, and *C*, upon the inside, prevent the gate from being opened.

### How to Make an Oil-Filter

**A** SIMPLE oil-reclaiming outfit may be made from a whole barrel and a half barrel. A funnel, terminating in a perforated pipe, is attached to the rim of the whole barrel as shown in this illustration. Water is placed in the upper compartment. If the filter is used where a stream of hot water or steam can be utilized, it will improve the action of the filter. In that case, place a loop of the pipe in the side of the barrel and keep the temperature of the water near the boiling point.

When the oil rises to the top of the barrel it overflows through the pipe at the left into the part below, where it passes through a strainer made of two thicknesses of cheesecloth. The complete outfit can be enclosed neatly and compactly in an outer covering of boards to represent a cupboard.

The oil reclaimed by this filter is good enough for all ordinary speed shafts or bearings. Accessories, such as a water overflow and draw-off valve, etc., for the top barrel, will suggest themselves to anyone sufficiently interested to construct a filter.—JAMES E. NOBLE.

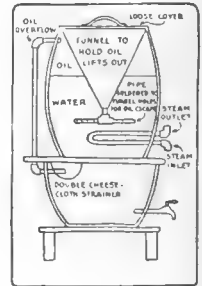

### String Holder and Cutter

**A** NOVEL device in the shape of a convenient holder and cutter for a ball of cord is here illustrated. The cutter is made in the shape of a sheet-metal collar with partly overlapping ends, these being sharpened so as to cut the cord. The cord is brought through a pair of holes in the cutter so that after the cord is cut the loose end

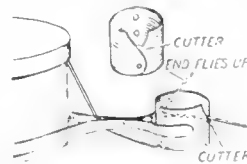

For holding and cutting twine

tends to fly up, owing to the elasticity of the string. The end then lies above the cutter where it can be easily grasped. The cutter piece is attached to the string box by a pair of sheet-metal arms.

Convenient Check Protector

**T**HIS device is valuable to persons who are required to write checks where a check-writing or protecting machine is out of the question. The principal advantage of this device is its compactness, inasmuch as it can take the place of the ordinary pen clip, thereby serving two purposes and always being at hand when required.

It consists of a piece of spring sheet-brass,  $\frac{3}{8}$  in. wide and 4 ins. long, bent to the shape of a long U (as shown in the illustration). A set of teeth (made out of brass or steel) is soldered on to the ends of the U-shaped spring (as shown in Fig. II), but the greatest care must be taken to insure the perfect meshing of

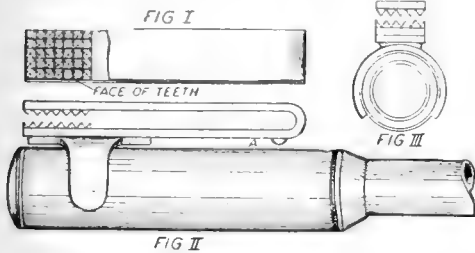

A check protector, a pen for writing the check, and a clip for holding the pen, all combined in one instrument

one set with the other; else the device will not work efficiently. The teeth should crimp and slightly perforate the paper. A drop of solder placed on the free end of the spring (as shown at A in Fig. II) enables one to slip it over the edge of the pocket and prevents the pen from falling out.

After filling out the check, place it between the jaws of the protector, with a portion of the lettering to be protected between the teeth. Exert a slight pressure with the thumb and then allow the spring to open. Slide the device along to another portion and keep repeating this operation until the whole amount to be protected is covered, thus making it impossible for anyone to tamper with the check without being detected.

Attachment for Oxy-Acetylene Torch

**T**HIS attachment is for a welder in filling low spots and holes in cylinders where it is impossible to get in with

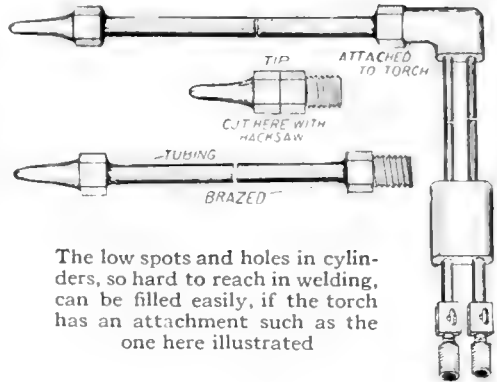

The low spots and holes in cylinders, so hard to reach in welding, can be filled easily, if the torch has an attachment such as the one here illustrated

the torch. It is made of  $\frac{1}{4}$ -in. heavy copper tubing. Obtain a tip of the size desired for the job and cut in half at the hexagon part. Then braze the tubing to the bushing part of the tip. Also braze the other end of the tubing to the other part of the tip. Anneal the tubing so that it will bend to suit the particular task in hand. This will work on all sizes of tips.—H. P. ALLMARAS.

Turning on Lathe with Calipers

**T**O use calipers when turning small or medium-sized work set them at the size of the piece to be turned down, and then after going over it roughly take a small, flat chisel in one hand. Hold the chisel over the rest against the wood and the calipers in the other hand over the revolving wood so as to size it by holding one side of the calipers against the chisel, sliding it back and forth on the chisel to allow the shavings to work off.

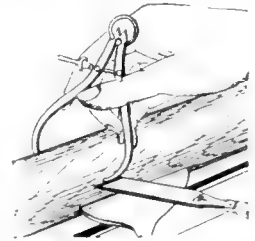

Calipers give accuracy in turning small pieces

This is a slow way, but a safe and sure one for accurate work.—W. F. GOOT.

Starting Your Automobile with Ether

**T**O start an obstinate automobile engine, purchase some ether in a paint store and prime your engine with it. Turn the engine over once or twice with the spark-switch off and then throw on your spark. With a half turn of the crank the motor will start.

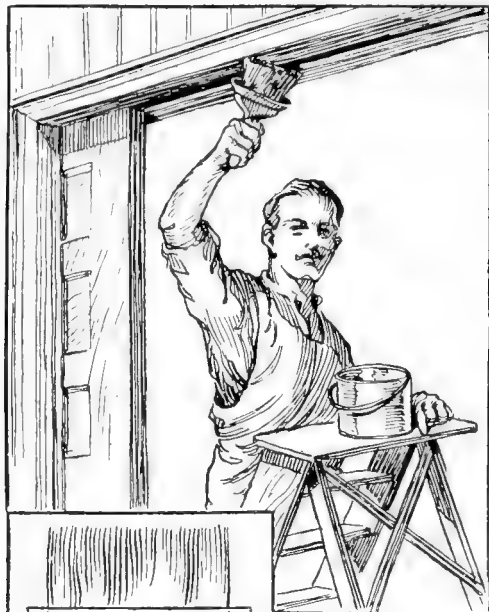

The inconvenience of painting overhead is obviated by using a shield brush which prevents the paint from dripping and splashing on the painter

### Protecting the Painter from Paint

WHEN it is necessary to paint a window or any object overhead the paint or liquid usually runs off the handle of the brush and then over the worker's hands. If you will take two pieces of tin soldered at the ends, and tack them on either side of the brush below the bristles, you will have a little cup which catches this overflow paint. Each time the brush is dipped into the paint-can the shield is automatically emptied.—C. H. THOMAS.

### Uses for Wire-Glass on the Farm

THERE are many places in and about the farm buildings where a stout, tough glass can be used to advantage. Wire-glass answers the purpose.

It is exceedingly strong, resists high winds, hail storms, and is an acknowledged protection against fire. Imbedded within the body of the glass is a meshed

wire made of iron which has a higher fusing point than glass. When glass is exposed to fire it becomes more or less plastic. Ordinary glass will crack, bend or shatter. With wire-glass the mesh which acts as a skeleton holds it in place. Even if the glass cracks, the pieces are prevented from falling, and sparks will not find an entrance.

When made wire-glass is poured over a red-hot iron table to the desired thickness. Red-hot woven wire-netting is then fed out from a machine, rolled, and pressed into this glass surface. The surface is smoothed or corrugated, according to the finish desired. It is then annealed to give it high resisting qualities. Wire-glass has the further advantage of not being readily affected by vibrations, and its great strength enables it to hold up unusual weights of snow and ice.

Many buildings on the farm would be improved by more light, but an ordinary pane of glass would not be strong enough. Here wire-glass can be used to advantage, giving more light from the roof or sides of the chicken-house, stable, or barn.

The farmhouse attic is often a dark, inaccessible place, which, if properly lighted, would serve as a valuable store-room or a delightful playhouse for the children in stormy weather. Here wire-glass can be used for skylights or partitions.—E. G. WALLACE.

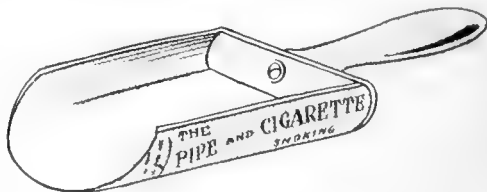

A tobacco or coffee can when cut and bent into the proper shape, makes a useful scoop with an old paint-brush handle

### A Home-Made Scoop

A HANDY little scoop may be made by trimming an empty tobacco or vegetable can to the shape in the drawing. To make the handle, take an old paint-brush, cut its handle off, and screw it to the bottom of the can with a round-headed screw and nut.

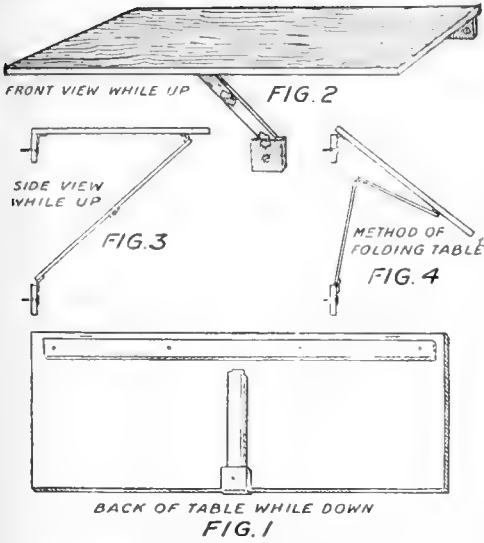

In a small kitchen, a folding table is the best for varied uses

Handy Folding Kitchen Tables

A FOLDING table which is firm and stationary when in use and which takes up no space in the room when not in use can be constructed by any one with available lumber and accessories. The table folds against the wall when not in use, and for this reason it is a great help in small bedrooms, where there is need for a table to hold instruments and medicines. It can be used as a writing desk or a dining table. Its chief value lies in the fact that it folds against the wall and thus takes up a minimum of space.

To Repeat Drawings

IT often happens that an artist has a design to repeat several times. Here's a quick way. Take a sheet of thin transparent celluloid and sandpaper one side to a ground glass-like surface. Place this over the design and trace the design with lead pencil on this roughened surface. Now turn this tracing down and rub the smooth side of the celluloid with the bowl of a spoon or similar smooth object. Several impressions may be made. With a little practice six impressions are easy to make. Use celluloid such as is in windows of auto-tops. It is very cheap, and the thinner the better.—ROBT. C. KNOX.

Fiber Disk Cutter

SECURE two pieces of 1/4-in. iron pipe 8 ins. long. In both ends of one of these pieces tap out 1/8 in. iron thread. In one end screw a short 1/8-in. iron nipple. This is for brace or lathe chuck. In the other end screw in a pointed plug of steel. Split the other 8-in. piece with a hacksaw (one end only), for about 1 1/2 ins. Open this up large enough to slip over 1/4 in. pipe. Drill the split end for fair-sized rivet or bolt 1/2 in. back from end. Drill the other 8-in. piece for this same rivet about 1 1/2 ins. from pointed end. Two ins. up from this point drill two smaller rivet holes as shown in the drawing. These are for a 6-in. piece of 1/4-in. pipe to be slotted as you have done with one of the 8-in. pieces. Rivet this securely. Near the end of this 6-in. piece cut an opening to receive a short piece of No. 4 wire. This is the spring guide shown in the sketch. L is a slip collar. M is a cutting point held in place by N, a set screw. K is a set screw for holding collar to shaft. J shows the method of fastening the 8-in. piece to main shaft A. Q shows the slot for I or spring guide. P and O shows the fastening for I to C.

This hinged joint at E and A, and spring H overcomes the difficulty when cutting with brace.

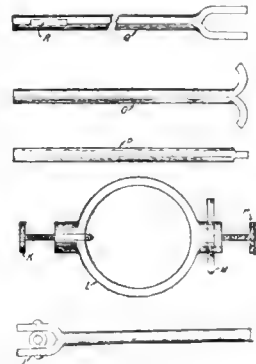

Various parts shown above are used in the fiber disk cutter

The parts are assembled by means of small rivets

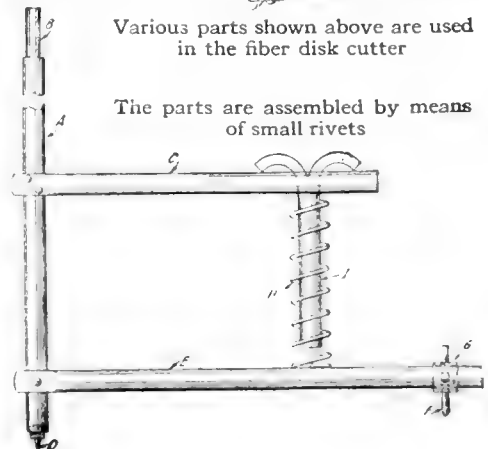

## A Cheap Surveying Instrument

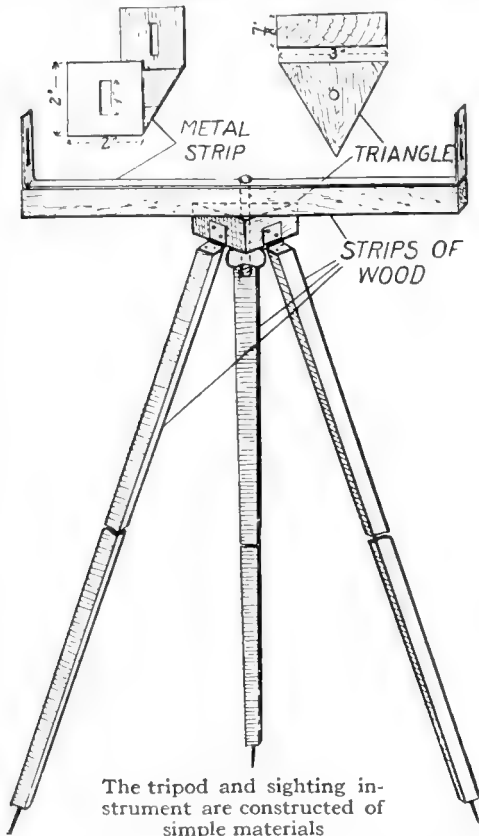

**T**O make a practical surveying instrument, take a piece of tin or sheet-iron two ins. wide and sixteen ins. long; a piece of 7-8 in. wood shaped like a triangle, three ins. on a side; three strips of wood as long as the distance from the ground to a little above your eyes when you are standing erect; one lath one foot long; and a wing-bolt.

Bend up the strip of metal two ins. from each end so as to form right angles. Beginning  $\frac{1}{2}$  in. from the top of the bent portions and extending to  $\frac{1}{2}$  in. of the bottom, cut a slit  $\frac{1}{4}$  in. wide to sight through. Screw or nail the metal strip to the short lath. Drill a hole in the middle of this apparatus to correspond with the size of the wing-bolt, and one in the center of the triangle.

Now make a tripod by hinging one of the three long strips to each side of the triangle. Put a nail, with the head filed off, in the bottom of each leg to form three anchoring points.

## To Re-Silver Old Mirrors

**F**IRST take off all the old silver by the use of nitric acid. Rinse with clear water and wipe off edges with a cloth. Polish the surface of the side of the glass to be silvered with rouge, so as to remove grease and any foreign matter. Then clean the rouged surface off with a brush and a solution of chloride of tin and water.

After cleaning thoroughly rinse with clear water and lay glass on a flat table that is level, being careful not to touch the surface.

Next make a solution of  $\frac{1}{2}$  oz. silver nitrate precipitate in ammonia with 8 ozs. of distilled water. Dilute  $\frac{1}{2}$  oz. of Rochelle salts in 8 ozs. of distilled water.

After these solutions are made and the glass cleaned and ready for the silver, take about 8 drahms of silver solution and 6 drahms of salts, mix, and pour same on glass with enough distilled water to flood the glass. Within three hours the glass will be resilvered.

## Temporary Pole-Steps of Spikes

**T**HE wireless amateur interested in outside aerials for his wireless equipment will soon find a demand for safe and substantial pole-steps on which he can climb Nature's antenna poles—the trees. Usually he drives in a nail at some close angle. But this is very unsafe, as he may lose his footing when he least expects it. In the method illustrated two 5-in. spikes are used in

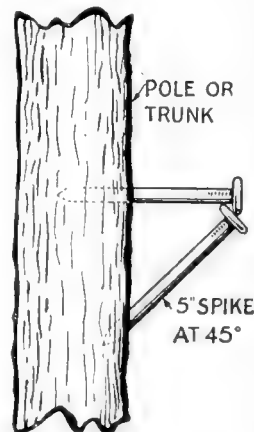

Heavy spikes make serviceable steps

making each pole-step, one spike being driven at a horizontal line, and the other directly beneath it at an angle of 45 degrees. The one at 45 degrees is driven in first, and then the straight one. The horizontal step has a tendency to depress the one on which it rests, and results in the former being driven deeper into the pole or tree trunk.

How to Keep Rope from Raveling

TAKE a piece of gas pipe about 1 in. long and just large enough to slip over the end of the rope and pull the rope through the length of the pipe. This is to get a firm end in the pipe. Cut off the surplus and then screw a stout screw hook into the center of the rope inside the pipe. This will expand the rope so that it is impossible to pull it out. By substituting a common 1-in. screw for the screw hook a rope end can be kept from raveling.

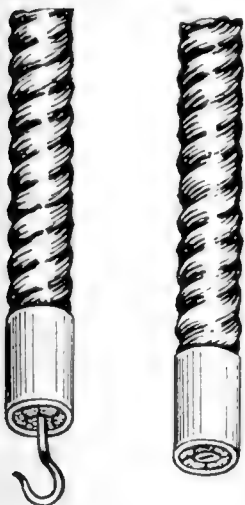

A short length of pipe and a screw prevent rope raveling

—JACK MILLER.

Smoothing Cross-Grained Wood

REMOVE the cap (curling iron) from a smoothing-plane. File the edge off squarely until it is 1/32 in. thick, instead of being sharp, as originally made. Replace the cap and set it very close to the cutting edge of the bit. This simple expedient will enable you to smooth any cross-grained wood or any wood against the grain, provided it is dry.—WM. C. TURTLE.

Regulating Shower-Bath Water

THE use of a water-mixer will prevent the annoying spurts of hot or cold water which often occur in shower-baths. Its cost should not exceed seventy-five cents or one dollar.

*D* is a cross 3/4 in. by 3/4 in. by 1/2 in. by 1/2 in. Hot and cold water enter at *A* and *B*. *E* and *F* are 2-in. by 3/4-in. couplings. *K* is a 2-in. iron pipe.

*I* is a piece of 3/4 in. iron pipe, cut on a slant, as at *M*. It is screwed through the coupling *E* and into the cross end. *II* is a 1 1/4-in. iron pipe, one end capped at *G*, the other end cut on a slant at *L*. It is simply placed over pipe *I*. The outlet of the mixed water is at *N*. If it is desired to use steam and cold water the hot water inlet is plugged, the plug *C* removed, and the steam pipe connected there. The mixer is made throughout with ordinary iron pipe and threaded fittings. In actual use it is impossible for the water to be either too hot or too cold if the mixer is regulated as it should be. To insure efficient service the mixer should be cleaned occasionally, preferably once in three months. This can be easily done by taking the apparatus apart.—JAMES E. NOBLE.

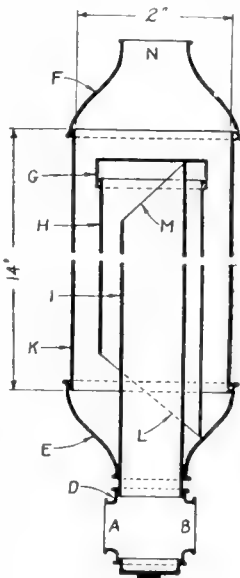

For regulating a shower-bath

Cutting Glass-Tubing by Electricity

TO cut glass-tubing of large diameter without breaking it, the following simple method is used. With a three-cornered file, make a deep scratch completely around the tube. To have the two ends of the scratch meet and to have a square end after cutting, wrap a narrow strip of paper with parallel sides around the tube and then draw file along the edge of the paper. Take a short piece of iron wire about No. 14 or smaller, and wind it once about the tube, so that it falls within the groove.

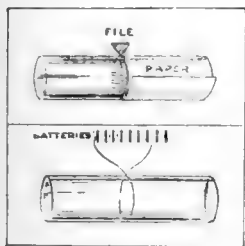

Making a neat cut

Fasten one end of the wire to the terminal of a storage battery and with the other end connect in series just enough cells to furnish current to heat the wire to redness. The sudden heating of the wire coming in contact with the cool surface breaks the glass along the scratch and with a little care even an inexperienced person may do efficient work.—W. A. SHEWHART.





# How to Make a Toy Zeppelin

By J. S. Zerbe

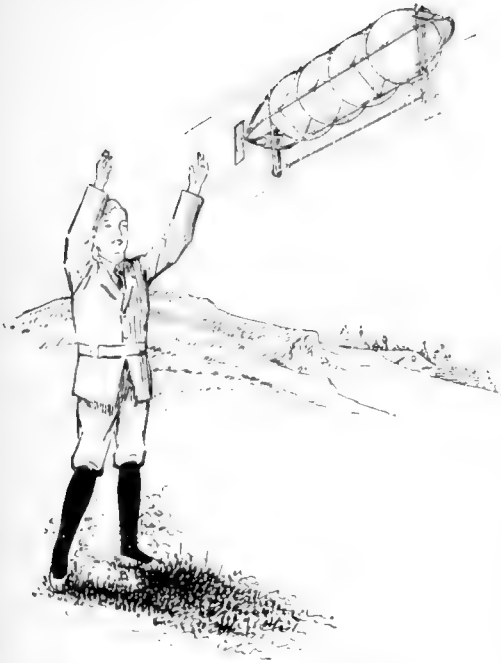

Four rubber balloons in a rattan frame, make a Zeppelin which will actually fly

A TOY Zeppelin is not a difficult or expensive thing to make in the home workshop. All that one needs at the outset is three or four toy balloons and some rattan strips. The first operation is to cut two conical pieces  $A A^1$  out of cork. These are  $\frac{3}{4}$  in. in diameter at the base, and  $\frac{3}{8}$  in. at the apex, the body being  $\frac{3}{4}$  in. long. This has four deep longitudinal grooves 1, and a shallow circumferential groove 2, midway between its ends.

Four lengths of round rattan, 3, 4, 5, 6, are then provided, each being  $\frac{3}{16}$  in. in diameter. This can be obtained anywhere, and is the lightest material for the purpose. The ends of these four pieces are attached to one of the conically-formed corks, as shown, after they are dipped in glue, and a string 7 used to hold them in place within the groove 2. The ribs thus secured together are ready to receive the balloonettes 8. The rattan ribs are brought toward each other, and the first balloonette placed in. A fine cotton thread 9 is then tied to

one of the rattan ribs, and carried down to the next rib and thus secured to the four ribs in such a manner that the ribs are parallel with each other. The three other balloonettes are then placed between the ribs and threads 9 used between the adjacent balloonettes to hold the ribs in alinement. The ends of the rattan ribs are then brought together and secured to a cork  $A^1$ , similar to cork  $A$ .

The cork and rattan frame are so light that the balloonettes readily lift the structure. For that purpose two bent pieces of rattan 10, 10<sup>1</sup> are used, placing one at each end of the frame, so that they embrace the upper and lower ribs 4, 6, to which they are firmly attached by threads. The lower or looped ends are some distance below the frame. The propeller is attached to the forward loop 10. It is made of firm cardboard, first steamed, after which the tips are twisted, and after being dried are fixed to the small end of a shoe eye 12. This serves as a

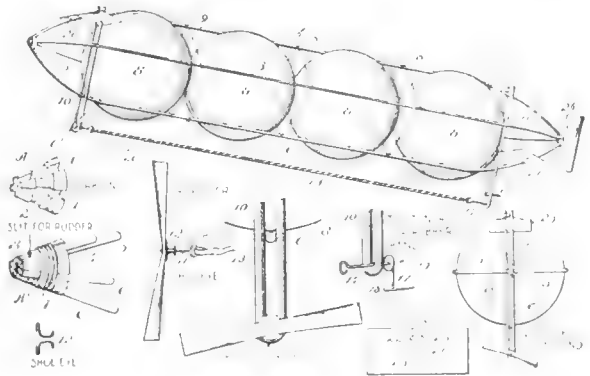

Details of the toy Zeppelin

bearing for the propeller. A wire 11, passing through the eye has a hook at its rear end, to which a rubber band 13 can be attached.

The other end of the rubber band is attached to a hook on the end of a wire

14, the body of which rests in the loop 10<sup>1</sup>. The rear end of the wire is bent at right angles, as at 17, and has a double bend as at 18, to furnish a crank, and also provide a means to lock the crank after winding up the rubber.

The next operation is to provide a pair of elevating planes and a rudder. The fore and aft planes are similarly constructed, the forward one 20, being attached to the upper rib 4, and the aft plane to the lower rib 6. Each plane is 2 by 4 ins. and at one margin is a pair of slits 22, 22, running into holes which are made to correspond with the vertical loops 10, 10<sup>1</sup>, to which they are attached. The other margin has a single slit 23, with a terminal hole, which is attached to the rib of the frame. These two planes are set at the same angle.

The cork at the rear end of the frame has a vertical slit 24, set at an angle, and in this a cardboard rudder 25 is placed. The only thing now necessary is to attach a cord 26 to the lower rib behind the first balloonette, and wind up the rubber band so as to twist it tightly. The moment the dirigible is free it rises, and moves forwardly, the two fore and aft planes keeping it on an even keel, and the rudder at the rear having been set to turn it, the machine flies in a circle, being prevented by the cord 26 from flying too high or far away.

#### Cover Lift for Cafeteria Platters

TO keep the food hot for "help yourself" cafeterias where large and heavy covers are used to protect the platters containing food, a chef has devised a means whereby the covers can be lifted to any position and remain in that position indefinitely. His device consists of two standards and a crossbar, made of pipe and fittings. The standards are about three feet long and the crossbar is long enough to pass over the platters.

Within the crosspipe are located small pulleys and holes made for the chain that suspends the cover. The chain runs over the small pulleys directly above the cover and then over another pulley fastened in the elbow of the pipe, and from there down the pipe below the counter where it is fastened to a weight.

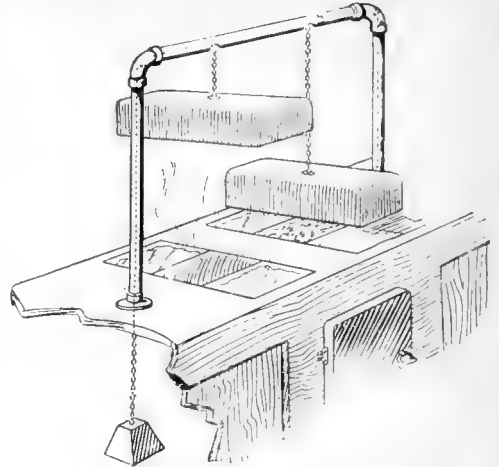

The pulley, chain and weight device lifts the covers out of the way

The lifting weight is sufficient to counter-balance the weight of the cover, so that the latter will remain in any position it is placed. When a customer arrives it is only necessary to give the cover a lift to present the steaming hot food in the platter.

The same cover lifts may be used for cold dishes or, in fact, for any dishes that are exposed to dust. The weight for lifting the cover is increased or decreased according to the size of the cover, and oiled joints insure easy motion at all times.—CHARLES F. SMISOR.

#### Putting New Life in Chisel Handles

CARPENTERS and mechanics know how soon the butt end of a chisel handle splits when daily exposed to the incessant blows of a mallet or hammer. To overcome this flatten the top of the chisel and attach, with a few small tacks, two disks of leather about  $\frac{1}{4}$  in. thickness to the flattened top. The leather disks should be the same size as the top of the chisel. If the disks overlap and expand they can be easily trimmed to conform to the handle top.—

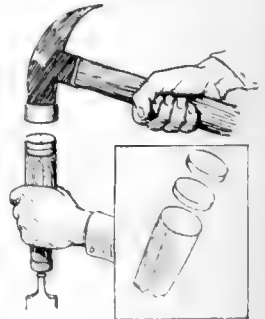

Two pieces of leather lengthen the life of the handle

HARRY A. SINGER.

**How to Make a Clevis Lock**

A CLEVIS lock will be found very useful. The size used to lock a boat can be made of five-eighths round iron, made in the form of a U.

The eyes must be at least one inch across and drilled to receive a half-inch bolt. The top eye should be counter-sunk or swaged at least five-eighths inch and very nearly through the eye.

The bolt has a thread on one end to fit the lower eye and the other end has a head which can be square, three-cornered, octagonal, or any shape desired. Immediately below this is a collar to keep the bolt from turning in too far.

A piece of gaspipe cut to the required

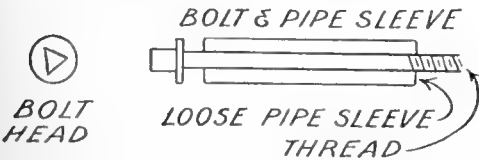
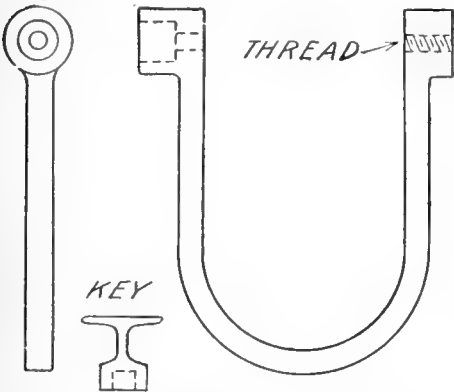

A clevis lock of simple construction

length protects the bolt from being turned in or out.

A small key should be made to fit the head of the bolt, which must be turned in at least one-half inch below the top.

This lock is secure. There is no danger of any one's unlocking it without the key made for it.—EARL B. SANDERS.

**A Handy Bunsen Burner**

THE need of a portable Bunsen burner is often felt by one working in the laboratory. The diagram shows how a very handy and useful device can be made.

The fitting from an incandescent gas



A handy portable gas-burner

light may be used for the mixer. This is to be extended to a length of 5 ins. by fitting a short piece of brass tubing. A 1-in. piece of brass tubing should be screwed to the other side of the fitting. An ordinary tool handle is drilled to accommodate this tube and it is shoved tightly in place, as shown. This tube affords an attachment for the gas hose.

The uses of such a device are countless. It is handier than a gasoline torch for soldering. It may be used for tempering and hardening. Clamped in a retort stand it is of use for many purposes where the ordinary Bunsen burner could not be used.—ROBERT KENNEDY.

**A Simple Overflow Alarm**

A NOVEL device which tells when the pan underneath an ice-box is about to overflow is easily constructed. On the bottom side or wall of an ice-box arrange a battery *A* and bell *B*. Leave the two ends of wire *CC*, which is an incomplete circuit, hanging down into the drip-pan into which water drips from the outlet *D*, above. A wooden float is placed in the pan and on it is attached a copper plate *F*. When the float rises the plate is brought into contact with the two ends of wire, completing the circuit and setting off the alarm.—M. J. SILVERSTEIN.



Under side of refrigerator, showing construction of warning device

## An Alarm Bell for Chemists

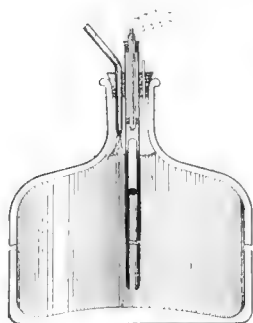

IN chemical laboratories, where various liquids are treated by slow processes, the receiving bottles often overflow, thereby wasting material and incurring a risk of damage, if the liquid is of a destructive nature. An attachment for bottles that will cause an alarm bell to ring can be installed cheaply.

The device consists of an electric contact made to close by the pressure of a float which rises in a tube as the level of the liquid nears the top of the bottle. A long tube, thrust through a rubber cork into the solution, contains a drawn-glass tip, from the ends of which platinum wires protude. At the upper ends they are connected to batteries and a bell. At the lower end they are bent into any desired shape, so that the circuit is closed when the float rises.

The float consists of a sealed-off glass tube containing a drop of mercury to prevent it from being too buoyant. The float can be tipped with metal, so that an electrical connection is formed between the wires when the tip touches them; or it may consist merely of the sealed-off tube, which, in rising, presses the wires together. The lower end of the tube containing the float is curved inwards, so that the float will not drop out when the device is removed.

## Getting Iron Scraps Out of Deep Holes

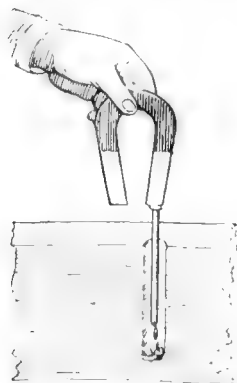

A PIECE of iron or steel can be removed from a small, narrow hole with the use of a horseshoe magnet and a nail. The nail is magnetized its full length and thus attracts the piece of iron or steel which can then be very easily removed.

## Rope and a Lever as a Pipe Wrench

SOMETIMES in tightening or loosening pipes and pipe fittings, a suitable wrench may not be at hand. This difficulty is easily overcome by using a piece of rope and a lever which may be a bar of iron, or a piece of pipe or wood.

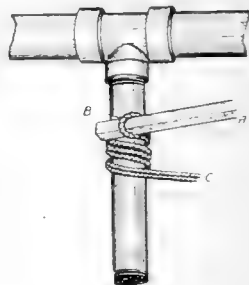

The method of using this device is shown in the accompanying illustration. The rope is doubled and given a few turns about the pipe (enough to insure a grip), the lever *A* is then inserted in the loop of the rope at *B*, and a strain is put on the end *C* to prevent the rope's slipping. The more turns of rope about the pipe, the less strain is required at *C*. The pipe is turned by the lever *A* the same as by any pipe-wrench used by steam-fitters.—WILLIAM PHILIP.

## A Safety-Holder for Hatpins

THE loss of an expensive hatpin may be prevented in the following manner. Cut 4 ins. from the point of an old hatpin; and bend it into a ring, allowing the point to overlap the blunt end about  $\frac{1}{2}$  in. Bend the point slightly to one side so it can catch on to the hat.

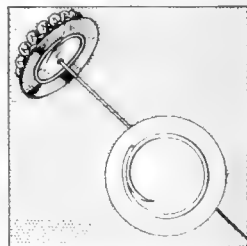

Solder the ring on to the back of the head of the hatpin. When the pin is inserted in the hat, it is slightly turned to enable the curved point to grip the material of the hat, thus preventing its being lost.—THOMAS SHEEHAN.

## Taking the Yellow out of Rubber

OFTEN experimenters find that hard rubber is affected by the sun, which gives it a yellowish color. A good remedy is to rub the rubber with dry pumice until the powder turns yellow and then to polish with carbon disulphide which can be bought at any drugstore. This gives it a beautiful black finish.

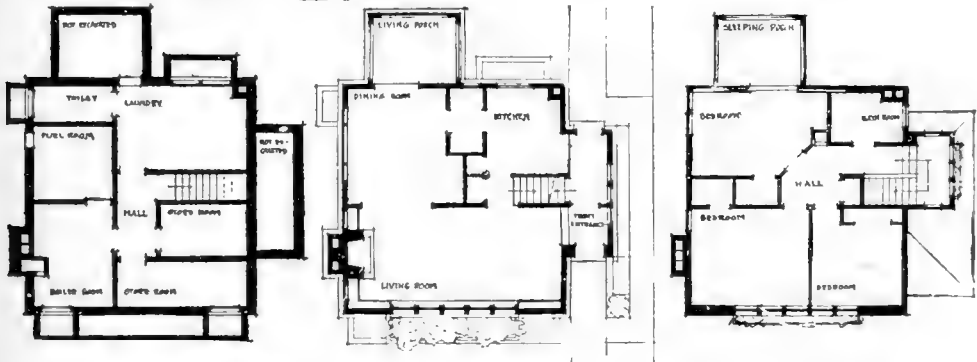
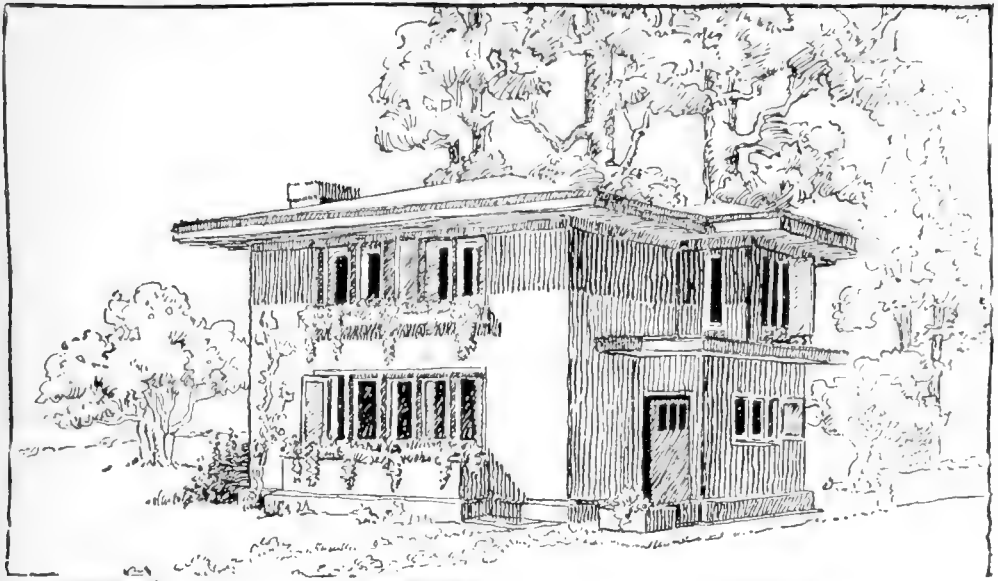

This house can be built for \$3500. It was designed by the Minnesota Art Commission

# What Home Builders Really Want

## Taking the Advice of Plain People

By Maurice Irwin Flagg

IT is hard to imagine art as a business builder for the farmer of Minnesota, or in fact of any other state. Most art programs shoot into space. They over-reach the mark, with the result that art, instead of becoming a common possession of the common people, is a pastime or pleasure and the plaything of the wealthy.

The Minnesota State Art Commission is a department of the state government. It was created by an act of the legisla-

ture some fourteen years ago. It has been slowly but productively tilling a virgin field which is now bearing crops far beyond the hopeful anticipations of those who were responsible for the commission's inception. The farmers in Minnesota are walking arm in arm with the art commission. The people of the small cities and villages consult the commission upon all sorts of questions. If the chimney smokes or the plumbing balks or the furnace fumes, the people



Model village house plans, some of wood and others of stucco, designed by the best architects in Minnesota, have been placed at the disposal of the small house builder. A photograph of this \$3500 house appears on page 320

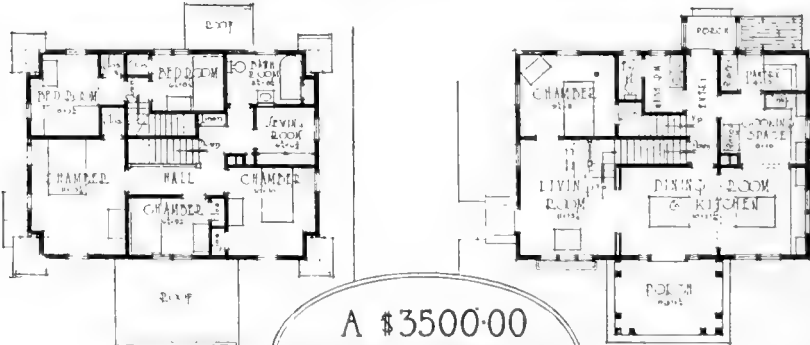

A \$3500-00  
MINNESOTA FARM HOUSE

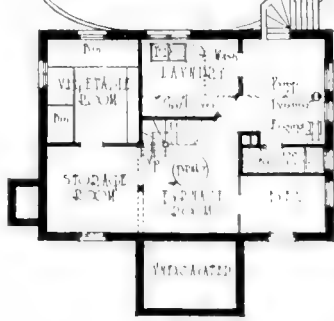

of Minnesota write to the art commission and get help.

During the last two years the Minnesota State Art Commission has distributed free over a million plans in booklet form for model farm and village houses. It helps people with their furnishings and labor-saving devices. It tells them about honest building materials, the right kind of paint, plumbing, heating, shingles, and

a thousand other things that contribute directly to the efficiency and beauty of home life. It supplies farmers with designs for the planting of farm yards. The commission has taken a new point of view and, assuming that art can be made to meet the needs of all the people, it has set about to find out what those needs are and then to supply them in a practical and businesslike way.



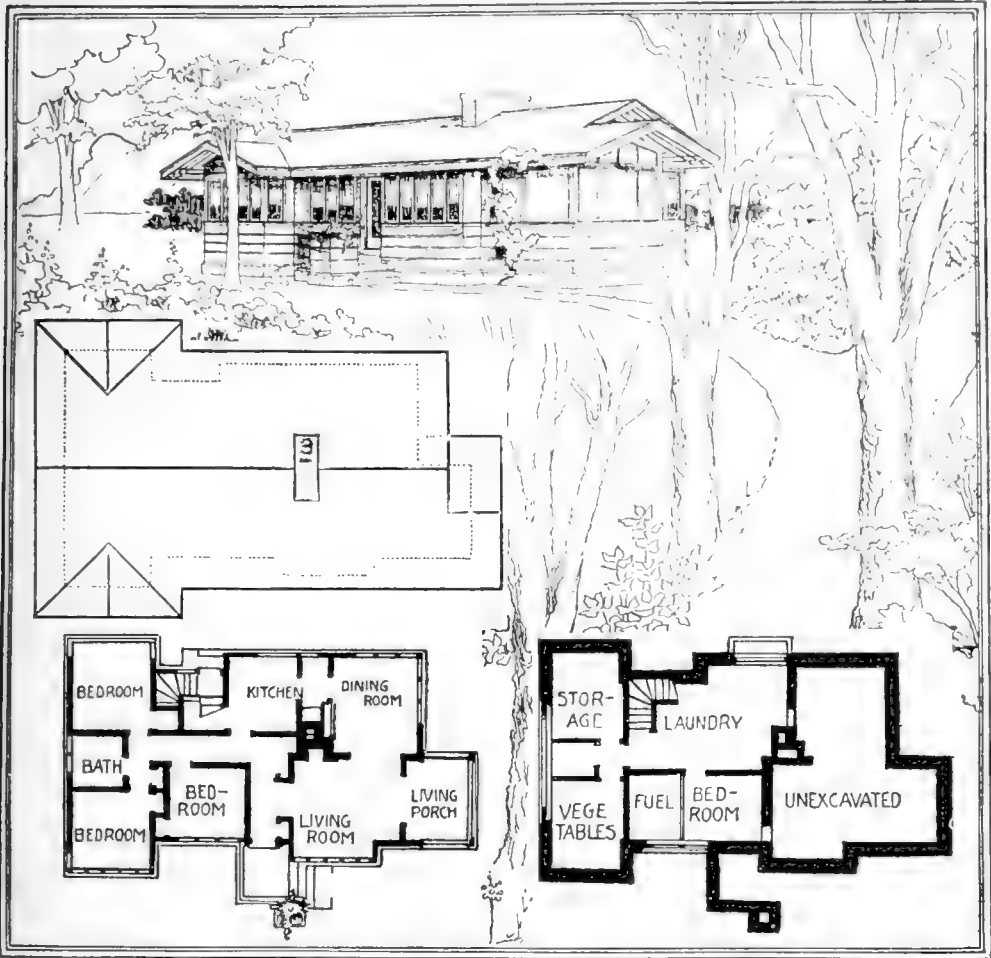

The artistic and the practical are being successfully combined in inexpensive western homes

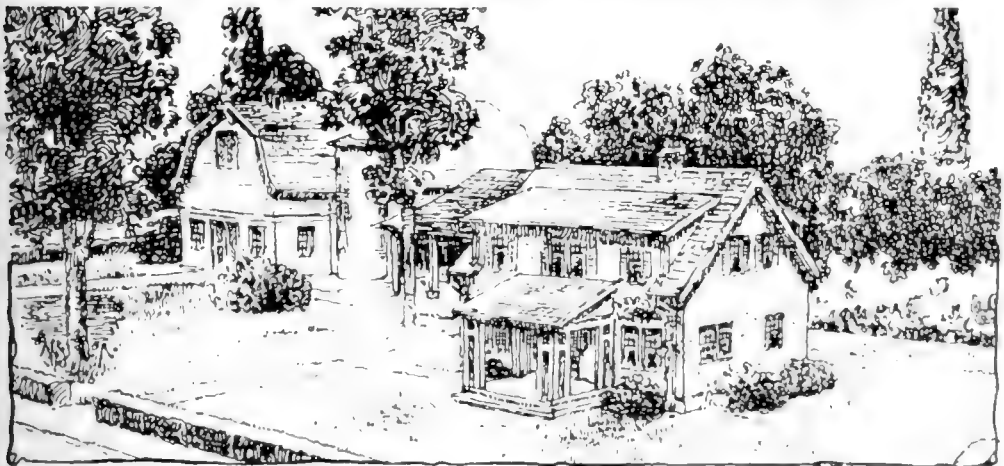

One western city is using twelve hundred of the model plans every month. They are placed in the public school to be studied

A meeting was called of practical farmers, art commissioners, architects and agricultural experts. The farmers said, "We want a farmhouse service if you can supply it. We don't want any city-made plan. We want a house with modern conveniences in farmer's style." "All right," replied the art commissioners, "Tell us what you want and we will give it to you." The farmers answered, "Ten rooms with a bath and separate quarters for the help. We want set tubs and running water, and labor saving devices because the farmer's wife is an asset that demands conservation. We want all this for not more than \$3,500." The art commission consulted the Minnesota Chapter of the

American Institute of Architects who agreed to endorse and support a model farmhouse competition. The commission raised a substantial amount of money for prizes, and the farmers dictated the terms of the competition. The farmers were asked to serve as a jury, along with the architects and agricultural experts.

The competition was open to anyone living in Minnesota. It brought together thirty splendid model farmhouses which were considered worthy to be judged in the final awards. But what was in a measure more hopeful than even the accepted drawings, were the hundreds of ideas submitted by farmers and farmers' wives from all sections of the state. Some of the plans were submitted on wrapping paper, others on birch-bark and still more on shoe-box covers, showing all the elevations, even the water running in the kitchen sink.

In two years' time, over a million plans have been sent from the offices of the State Art Commission and these in booklet form, free. If a farmer wants full size working-drawings and specifica-

tions, he can have them for just the cost of making the blueprints. Working drawings are sold by the commission for \$3.50 to anyone living in Minnesota and \$5.00 to anyone living outside the state.

The commission set about to build a model farmhouse for demonstration and through the co-operation of the building material interests it built upon the State Fair grounds a complete first prize design. This house is properly landscaped and furnished from attic to cellar. Every labor-saving device and every modern convenience shows the farmer and his wife what can be done for a certain amount of money.



Model Minnesota farmhouse erected on the State Fair Grounds. The plans are given on page 318

A new kind of farmhouse is being built in Minnesota. The plans have been sent to

the far corners of the United States and other countries. The plans and even a small-sized model have circulated through Minnesota to farmers' institutes and short courses. The farmer and the Art Commission in Minnesota are on speaking terms now. The commission is able to assist in the selection of the wall paper. And this helps some in advancing the cause of pictures and "old masters."

This farmhouse campaign was only a beginning. People living in the small towns and villages said, "Why not do something for the small home builder who cannot afford to employ an architect? You have helped the farmer, now do something for us." A second competition for a model village house was held. This house was to cost \$3,000 complete. The architects enthusiastically endorsed and supported this competition and from it came some fifty of the most attractive and "architecturally fit" houses that have ever been accumulated. The immediate result was a great state-wide interest in better farm-homes and a quickening of home interests.

# The October Issue of The Popular Science Monthly

## What the War Has Done For the Aeroplane

The battlefield is to the aeronautic engineer a huge laboratory for the testing of aeroplanes. More progress has been made in designing flying machines since the war began than most of us imagine. Wouldn't you like to know just what the war has done to bring us measurably nearer the day when we will trundle out a flying machine as easily as if it were an automobile and whirr away from our country homes to our offices? The October issue will tell you.

## Handling New York City's Traffic in a New Way

New York, the greatest city of the Western Hemisphere, is a little, long island, packed with people, trolley cars, wagons, dwellings and office buildings. It has the most difficult traffic problem in the world. To handle the millions and millions of tons of freight brought in by steamships and railways, a crude and antiquated system is still in vogue. In the next issue of the POPULAR SCIENCE MONTHLY we will tell how great engineers propose to solve this traffic problem scientifically.

## Harnessing the Sun in Egypt

The sun is hot. Every boy knows that who has ever used a burning glass. Isn't there some way of heating water with the sun and driving a steam engine—some way of putting the sun to work? The POPULAR SCIENCE MONTHLY for October will tell all about the wonderful plan of a Philadelphia inventor to harness the sun.

## Motoring on Roller-Skates From Home to Office

It sounds fantastic, but inventors have been so successful in motorizing the roller-skate that before long it will be possible to skate your way to work each morning. Read about it in the October issue.

In the same issue and regularly thereafter you are to be informed of the latest happenings in the great field of astronomy.

These are only a few of the articles which are to appear. Remember that each month there are three hundred articles and as many pictures—all intensely interesting, all dealing with new things in science and invention which you ought to know to keep abreast of these stirring times.

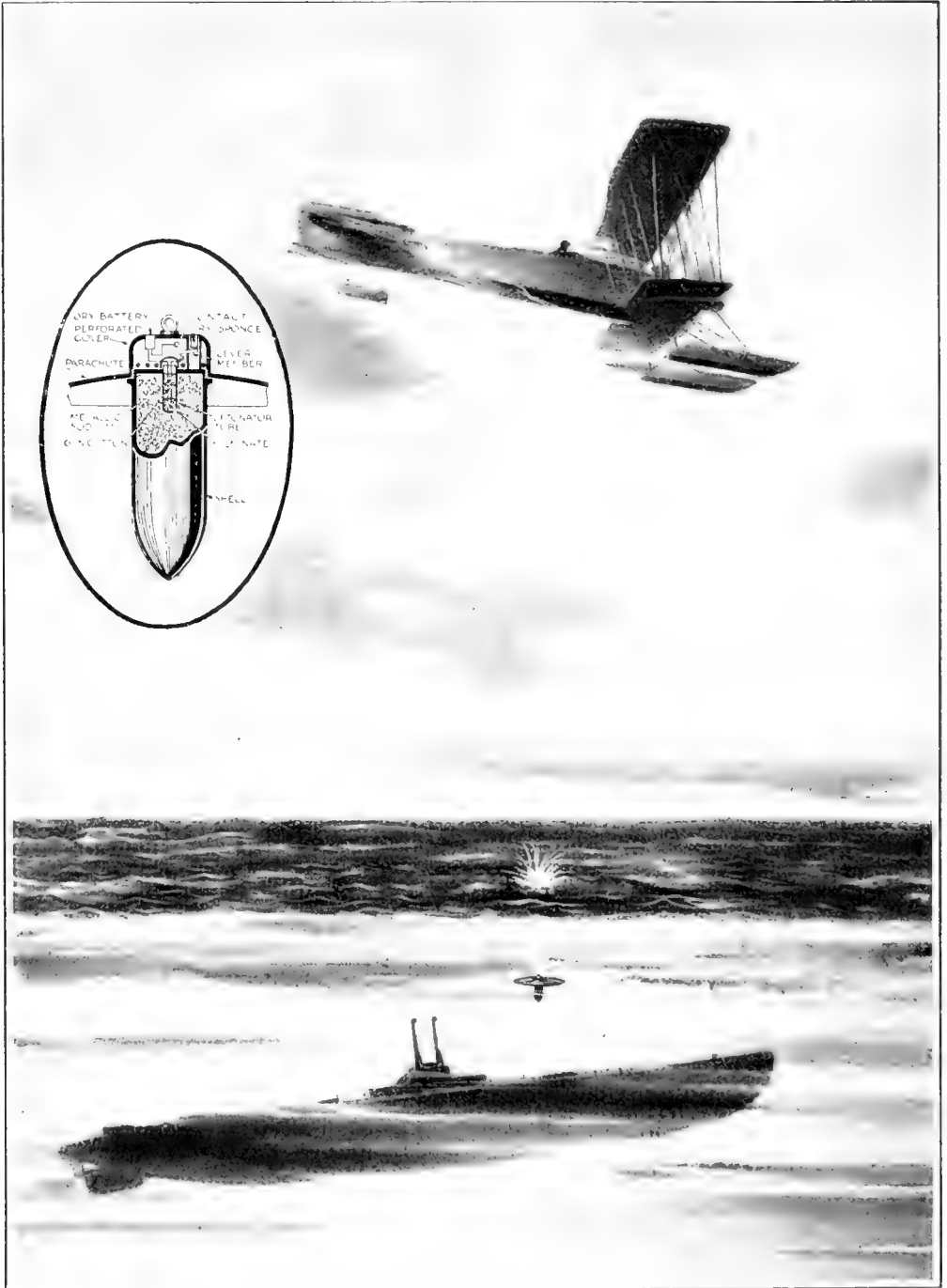

The airman is monarch of all he surveys including the enemy submarine submerged thirty to forty feet under the water which is perfectly visible to him. He releases a bomb which is guided in its descent to the water and its speed under the water by the parachute, which is a dished circular plate. Two means are used to explode the bomb. Water flowing in through perforations either fires a quantity of sodium which in turn discharges the fulminate, or it completes the circuit of an electrical igniting apparatus setting off the bomb

# Popular Science Monthly

239 Fourth Ave., New York

Vol. 89  
No. 3

September, 1916

\$1.50  
Annually

---

---

## Torpedoing a Submarine from an Aeroplane

**B**ECAUSE an airman flying above the water can sight an underwater craft and detect its approximate depth with the naked eye, inventors have devised a number of bomb-dropping contrivances in an endeavor to make the most of this strategic advantage and place the submarine at the mercy of the aeroplane. One of the most recent of these devices is an aerial torpedo or bomb containing high explosive which when dropped from the aeroplane makes a rapid and straight descent beneath the water and explodes at the proper depth and proximity to wreck a submarine.

The bomb consists of a shell filled with high explosive and into its closed end is fixed a detonator which consists of a tube containing a layer of metallic sodium, a layer of gun cotton and a layer of ordinary fulminate. Attached to the shell is a parachute, which is nothing but a dished circular plate. This acts as a guide in the descent of the bomb from the aeroplane to the water and also regulates the speed of the bomb once it is under water, allowing it to sink slowly.

The cover of the bomb as well as the cap of the detonator-tube are perforated. When the bomb has sunk to a certain distance, water flowing in through these perforations ignites the sodium (a property of sodium), which fires the gun cotton, which discharges the fulminate, which sets off the bomb. These different stages leading up to the actual explosion occur nearly simultaneously, but should they fail—that is, should the unforeseen happen and the sodium not ignite, an electrical igniting mechanism is provided which will discharge the fulminate.

Within the shell there is a dry battery connected to a contact point and to one end of a platinum glow wire embedded in the fulminate. The other end of the glow wire is connected to an insulating lever carrying a contact point. This lever member is a closed hollow tube containing a little mercury, which, flowing to the lower end, tends to keep the lever down. A tube in the perforated cover contains a bucket filled with a dry sponge.

When once the bomb has struck the water and the sponge has sufficiently absorbed it, its weight bearing on the end of the lever member raises this lever into contact with the terminal, thus completing the circuit and discharging the fulminate.

There are several very obvious objections to a bomb of the type described. It is very difficult to hit an object on the ground when the aeroplane is very high. Indeed, no satisfactory instrument has thus far been invented to drop bombs from great heights with anything like the precision that marks the firing of projectiles from great guns. If the aeroplane is to destroy a submarine in the manner proposed, the bomb-dropper must be very near its target—so near that it would itself be in danger from gun fire.

Some of the difficulties of dropping bombs accurately spring from the fact that an aeroplane moves through the air at a rate of at least forty-five miles an hour. Allowance must be made not only for that forward movement, but also for the movement of the submarine as well as for the wind. A hit would therefore be almost a matter of luck.

### Ferretting Out the Secrets of the Golf Ball

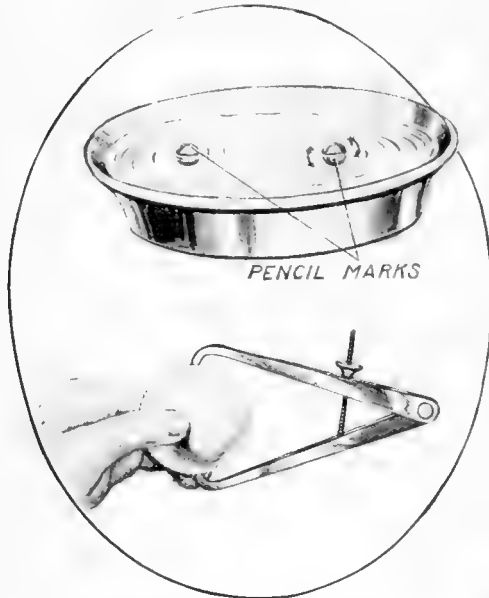

Two Tests to Determine Whether or Not a Golf Ball is "Lop-Sided"

**W**HAT is the most efficient type of golf ball? A well-known British scientist and golf enthusiast has made some exhaustive tests with golf balls of various sorts under various conditions. He finds that the average golf ball is altogether too rough and that the center of gravity is often misplaced. Accordingly, he experimented and the following rules are the result:

1. Float the ball in water until it becomes stationary. Mark it with a pencil and roll it slowly. If the mark comes up slowly the center of gravity is fairly accurate. If it comes up swiftly, the ball is "lop-sided."

2. Measure the ball at various points with calipers, to determine whether or not it is absolutely spherical.

3. Test one ball against another, for elasticity, by bouncing.

4. Throw the ball under examination straight up in the air in a heavy breeze. If bad, it will swerve.
5. Choose the smoothest ball.

### A Metal Disk Supplants the Golfer's Tee

**P**RACTISING golf on the lawn at home is not as full of pleasure as it sounds, unless one cares to import enough sand or dirt to build the necessary tees. But where a metal disk is provided—a disk which takes the place of the accustomed tee and performs its duty with every degree of thoroughness, it is possible for the golfer to continue his practice without inconvenience.

The disk illustrated is very light. At the same time it is serviceable. The player can utilize it in two ways. He can substitute it for a dirt or sand tee, or consider it a hole and improve his putting thereby. With the disk it is not necessary for the golfer to confine his practice to the lawn.

If the weather is inclement the disk will serve its purpose inside the home.



A Feather-Weight Disk Which Takes the Place of the Accustomed Tee

Maybe you have special needs. Write to the editor about anything within the scope of the magazine. He will be glad to help you.

Golfing by the Clock—A New Idea  
for Golf Courses



The Clock on Its Pedestal Is Located Where It Can Be Easily Seen from Club House and Course

A NOVELTY in the way of a holder for the golf course clock has made its appearance on the grounds of the Annondale Golf Club in Los Angeles, California.

This is a conspicuous all-concrete structure, standing about eight feet in height. The case containing the clock is two feet wide, two feet in height and a foot and a half in depth. Its walls are about three inches in thickness. A removable piece of plate glass occupies the front side of this case, while in the rear there is a small door through which the clock may be regulated. The standard is solid and is about a foot in thickness at the base and eight inches in diameter at the point where it meets the bottom of the case.

This clock and its holder are located beside Tee No. 1 of the course. It can be easily seen by those who are about to start upon a round of the course, as well as from all parts of the club house, from which it is a few yards distant.

What Golfing Sometimes Does  
to the Feet

A SPECIAL "jinx" of the old golfer has been classified as "golfer's foot." It is a condition due to broken or fallen arches. When playing golf the anterior portion of the foot, in right-handed players, and vice versa in left-handed players, is brought into unusual service. As the drive is made the weight of the body is brought back with great force upon the foot that has been elevated in the up-swing. The greater part of the force is caught by the outer portion of the foot and inevitably the strain will be felt, especially if care is not taken at the beginning of the season to keep the feet in good condition.

Making Your Head Behave  
While You Hit the Ball

A DEVICE to make the golfer keep his head still while making a shot has been invented by Arthur E. Peck, of Minnesota. It consists of a sight that is suspended by a rod fastened to the front of the player's cap.



The Sight Makes the Player Keep His Head Still When He Swings to Hit the Golf Ball



The Paddleless Canoe in Action. The Operator Propels Himself Leisurably Along with the Aid of Either His Hands or His Feet, or Both Combined When Making Speed

Below, the Neat and Compact Propelling Device Which Weighs About Forty Pounds. The Upright Lever Operates the Rudder. The Principle Is That of a Velocipede

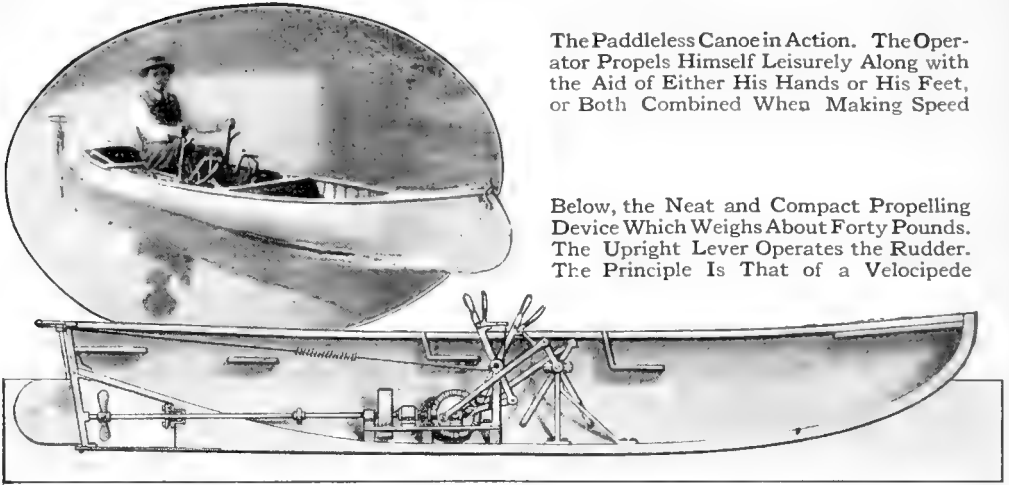

#### A Paddleless Canoe Propelled by Feet and Hands

WHEN George D. Sicksteel, of Oregon, goes for a sail with his little canoe he forgets all about the rising cost of gasoline and engine trouble and propels himself up and down stream with a hand and foot-operated boat of his own construction.

The hand levers are connected with a crank which carries a gear, and this meshes with another gear which drives the propeller shaft.

Pedal cranks are connected with the same crank which is operated by hand levers, so that the boat can be driven by foot as well as by hand-power. In this way the operator can use either one hand or two hands, or both feet alone, or both hands and feet together. The apparatus weighs about forty pounds.

#### A Machine That Cracks Oil-Bearing Nuts Without Crushing Them

THE bursting and cracking of cocoanuts, cohune nuts and nuts of similar nature to enable the oil-bearing kernels to be extracted with the least possible waste has long been a tedious hand process. A machine has been invented by an English firm, which is said to crack the nuts more quickly and with less waste than any apparatus heretofore devised. The pressure is applied to the nuts lengthwise, and each nut is

placed in a position between the bursting jaws, hollowed out so as to safely hold the "nose" or rounded part, and is there cracked. As fast as one is cracked another is lifted in position, so that the operation is continuous. The operator simply turns the crank, and the nuts are cracked as fast as they are fed to the bursting jaws.

Below the machine is a hopper containing the supply of nuts. A belt carrying lifting forks enters this hopper and lifts the nuts one by one to the bursting jaws. One revolution of the driving shaft, operated by the crank, crushes a nut, which falls in a receptacle. At the same time another nut is brought in position, is cracked, and falls in the same receptacle. The machine does not injure the kernels or waste the oil.

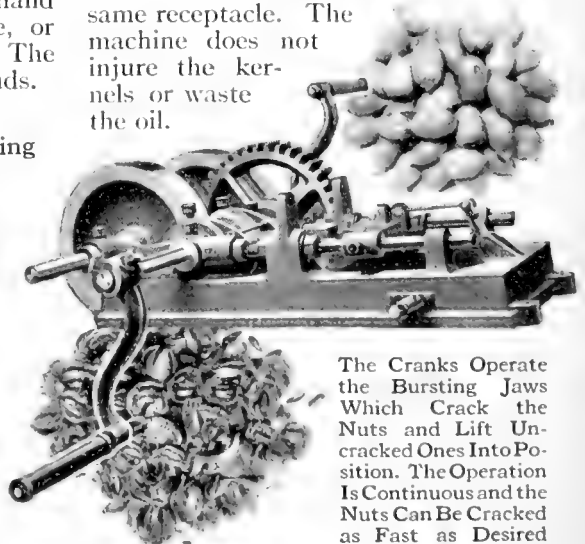

The Cranks Operate the Bursting Jaws Which Crack the Nuts and Lift Un-cracked Ones Into Position. The Operation Is Continuous and the Nuts Can Be Cracked as Fast as Desired



How the Stone and Old Concrete Were Removed from the Basin by the Improved Cableway

### A Substantial Cableway Built from Scrap Material

**I**N removing a quantity of stone and old concrete from the interior of a fifteen-million-gallon reservoir under construction in Omaha, Nebraska, the cableway illustrated was built from scrap material in a short time by the blacksmith on the job.

The "A" frame was built with an old 10-in. sheave at the top, over which passed the carrying cable. This was a piece of ordinary galvanized strand such as is used for guy wire, and the hoisting line was  $\frac{3}{4}$ -in. manilla rope. The carrier was built of  $\frac{3}{8}$ -in. by 1  $\frac{1}{2}$ -in. flat iron, using sheaves from old pulley blocks for the running and hoisting sheaves. The movable block, to which was attached the hook for suspending the load, was an 8-in. block with a long pin through the sheave to engage the stop on the carrier when the tackle was at "two-block." The wheel-barrows were attached by a three-chain grab.

With the cableway in operation, the wheel-barrows were loaded inside the basin, wheeled under the lower stop of the cableway and the grab chain attached. The load was raised by a hoisting line to the "two-block" posi-

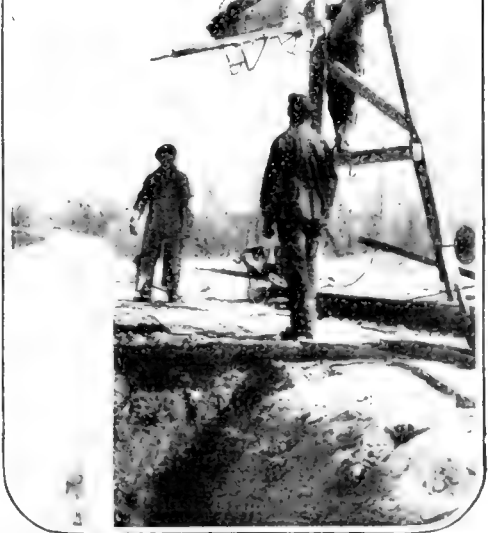

Releasing the Hoisting Line at the "Two-Block" Position Lowered the Wheel-Barrow

tion, and then hauled up on the carrier line. Upon reaching the head frame the long hook was dropped to engage a pin in the top member of the carrier. When the hoisting line was released the wheelbarrow was lowered to the ground. The grab chains were released and the load wheeled to the dump. An empty wheelbarrow was then attached, hoisted to the carrier, the hook released and the load sent to the floor of the basin. On this work a small hoisting engine was used.

# The Senators' Subway

By L. W. Lamm

With the Completion of the Senate Office Building in 1906 the Necessity of a Subway from the Building to the Capitol Became Apparent. The One Here Shown Has Just Been Completed

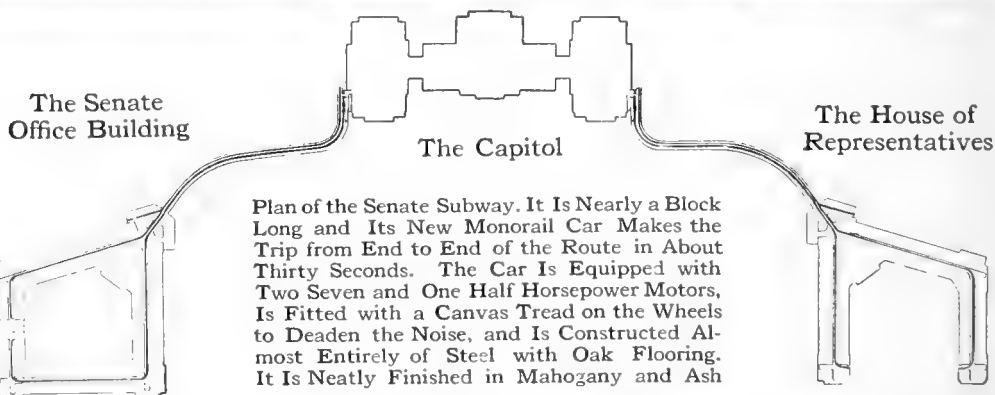

**A** NEW monorail car has been put into operation in the subway between the Capitol building and the Senate Office Building, at Washington, D. C. A car of similar construction has been in service up to now, but the old car was slow and seated only twelve persons. This new car, which was designed and built under the direction of the office of the Superintendent of the Capitol, Elliott Woods, has a seating capacity of eighteen, makes faster time and is less noisy.

Built for the most part in the machine shops of the Washington Navy Yard, the new car makes about one hundred and twenty-five round trips a day in the tunnel, on what is perhaps the shortest railway in the country, seven hundred and fifty feet long. The car

weighs two thousand five hundred pounds, is eighteen and a half feet overall and forty-six inches wide.

One of the features of the new car is the seat for the "motorman." He sits in the center, and without getting out of his place, makes the car go either way. This, in itself, is a time saver. It is estimated that the car can make twenty-five miles an hour. It takes just thirty seconds to go from one end of the subway to the other.

The car is equipped with two seven and one half horsepower motors, is fitted with a canvas tread on the wheels to deaden the noise, and is constructed almost entirely of steel with oak floors. It is finished in mahogany and ash.

In 1906 when the Senate Office Building

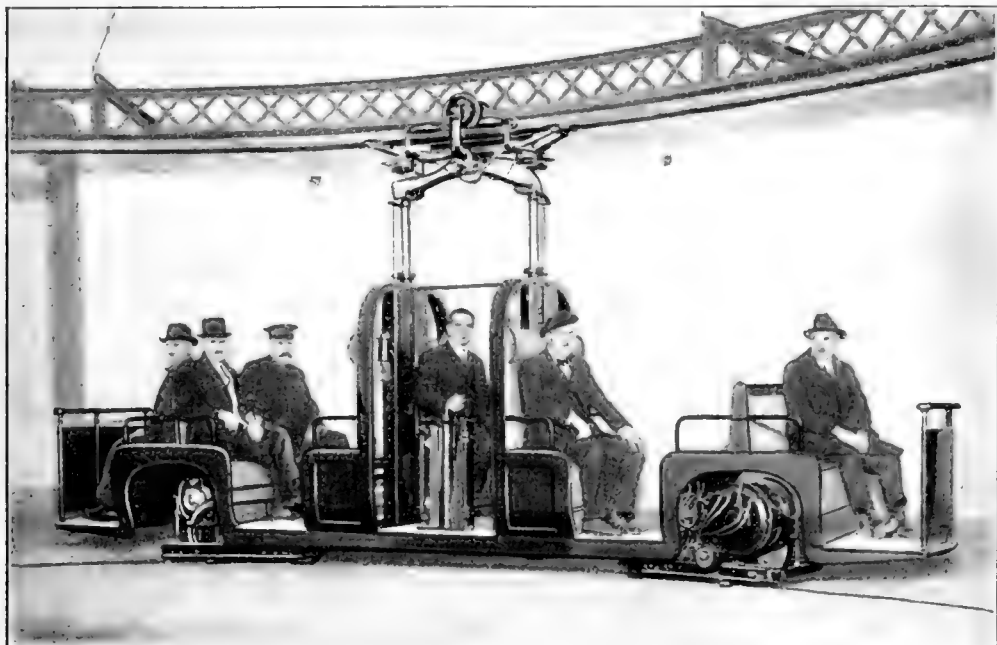

The New Car Has Seating Capacity for Eighteen Men. The Motorman Sits in the Center and Does Not Have to Change His Position to Reverse the Car

was just about completed it was decided that a "subway" under the parking between the Capitol and the building was a thing to be desired. Behold, it was done. It is nearly a block long. At first the Senators were satisfied to walk. That was too slow, especially when they were hurrying to the Senate chamber from their offices to vote. An electric automobile, with a capacity of about twelve persons was then installed. This was well enough for a while, but even this was slow. The monorail car was then put into operation, which has been fast enough up to now, but even that was slow and so the latest product has just been installed.

#### And It Looks So Small On the Map!

**E**VERY four years New York city takes unto itself a city the size of Boston or St. Louis.

New York is the largest Jewish city in the world. It is the largest Irish city, there being 674,721 of Irish blood here. There are 723,333 Germans, 306,422 Austrians and 735,477 Russians.

There are 3,087 miles of water pipes

under the city; the capacity of the reservoir is 170,000,000,000 gallons, and the conclusion of the Schoharie project will add 80,000,000,000 to this.

Every day 290,000 persons arrive or depart from the city through the railroad stations.

The railroad systems terminating in New York have a mileage of 45,323 miles, or 18 per cent of the total mileage of the country.

Every thirty minutes a new business corporation is formed in New York and every forty-five minutes one is dissolved.

Every four minutes a new being is born, to have the proud distinction of being a native New Yorker. Babies to the number of 150,000 were born there last year.

New York has 38,000 factories. They employ capital amounting to \$1,800,000,000 and turn out \$2,000,000,000 worth of goods a year.

Every day the traction facilities carry 4,067,680 persons.

The city has 198 parks, with an acreage of 8,615. It has 1,500 hotels. More than 500 conventions are held there a year. There are thirty-one post offices.

### Making the Scallops on Plate Glass



The Tool Grasps the Edge of the Glass Plate and Bites It Off With a Tooth or Point

**WILLIAM SPANGLER**, a resident of Illinois, has invented an improved glass-chipping tool which has for its purpose the ornamentation of plate glass by scalloping. The ordinary glass-chipping tool can be used on glass of one thickness only, and when a plate of another thickness is to be chipped another tool must be employed. The tool grasps the edge of the plate between a bearing point and a bit and bites it off with a tooth, or point, provided for the purpose. In order that the same tool may operate successfully with varying thicknesses of glass it is necessary that the space between the bearing point and the bit be adjustable—in two directions—transversely of the edge of the glass and longitudinally of the handle of the tool, so that the bearing point shall impinge the glass at varying distances from the edge.

The invention referred to provides for this double adjustment of the jaws.

### How Heat Is Measured with the Eye

**N**OW that man has succeeded in obtaining artificial heats that almost rival the intensity of the sun, the accomplishment has made the demand upon him that, in harnessing this terrific heat for industrial purposes, he shall devise some means of measuring it. For many years after electric heat was known and used industrially the exact temperatures which existed were only guessed at. Recently, an instrument known as the thermo-electric pyrometer has come into use, but this ingenious type of thermometer has the serious limitation that it will melt when the temperature has passed a certain point. The latest development in heat-measuring devices is an optical instrument, which, while it is placed in operation many feet from the heat source, will measure the temperature with a fine degree of accuracy.

The "sight pyrometer," as it might be called, really takes up the measurement of temperatures where the ordinary pyrometer leaves off. It can safely and accurately measure heat at temperatures as high as 7200 degrees Fahrenheit. The

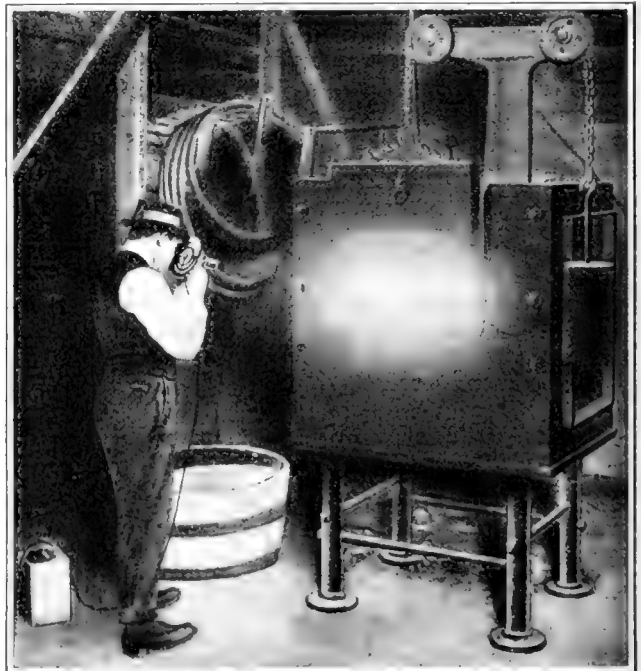

Measuring Heat-Treating Temperatures With the "Sight Pyrometer" Many Feet from the Heat Source

minimum temperature it will record is 1200 degrees.

The principle upon which the operation of the sight pyrometer is based is the simple physical law that the intensity of light emitted by a heated body is directly proportional to its temperature.

In looking through the pyrometer, two adjacent semicircular fields of vision are observed, one being illuminated by the small standardized electric lamp in the pyrometer and the other by the object whose temperature is to be measured. The red ray of the spectrum is used and very slight differences in the intensity of the heat in the object under investigation produce quite perceptible differences in the shade.

In taking readings, the intensity of the field illuminated by the lamp is adjusted by turning the eye-piece until the line separating the two fields is eliminated, and the corresponding temperature is read directly from the dial. The matter of bringing both fields of vision to correspond is not a personal

one of matching colors. There is always a line between the two fields when they do not correspond; therefore, it is simply a matter of eliminating this line, and any defects of vision are equalized.

The handling of the pyrometer requires no special knowledge, and readings within ten degrees of each other can be made by any workman of average intelligence. In making observations the temperature of the object itself is measured. It is this temperature and not the heat of the furnace that

determines whether the object is being treated at the proper temperature to produce the effect desired. For metallurgical operations the ideal pyrometer never comes in contact with the heated object—in fact, no heating of the instrument is required, and the readings are taken almost instantaneously. It can also measure heated moving bodies.



Measuring the White Heat of Molten Minerals. The Shield Protects the Hands of the Operator. The Instrument Also Measures the Heat of Moving Bodies

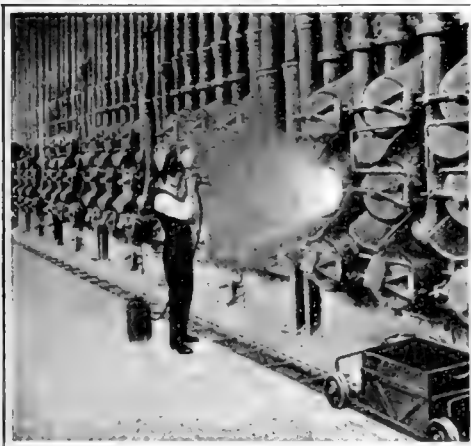

The Intensity of Light Emitted by a Heated Body, Regardless of Size, Is Directly Proportional to Its Temperature

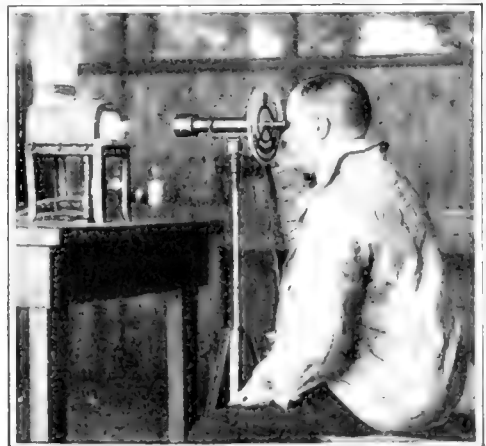

In Looking Through the Pyrometer Two Adjacent Semicircular Fields of Vision Are Observed with the Operator's Eye

### This Automobile Seat Serves as a Waiting Room

A REAL estate man of Los Angeles, California, has found a new use for the rear seat of a worn-out automobile. He came into the possession of an automobile which was ready for the junk pile.

Realizing his immediate need of a resting place for the patrons who visited his little office he saw that some other place must be provided if his customers were to be well taken care of. He thought of the old automobile war horse that stood in his back yard. After some consideration he decided that the rear seat of that "tub" was just what he wanted. So, he took it down and planted it in the parkway directly in front of his office. And there it is now in royal dignity.

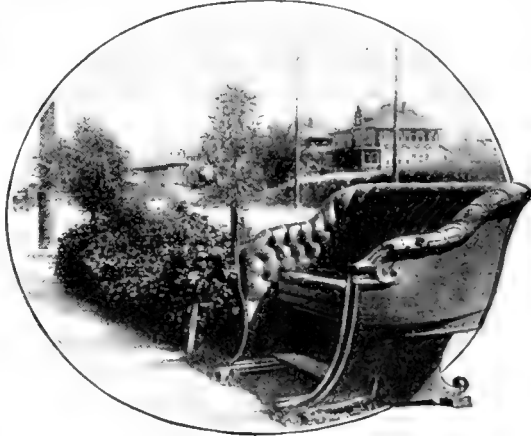

A Comfortable Resting Place for Customers Waiting Outside This Dealer's Office for a Car

square or circle of water, which can be confined exactly to a given area, large or small. The device is so small that it can be carried in the pocket, but it covers eight hundred square feet of lawn surface, if the water pressure is good enough.

One kind is required for a square lawn, however, another kind for a round lawn and still another when the shape is oblong. A special sprinkler is also made for sloping ground. The sprinkler is placed at one side of the lawn when in use and can be moved about without wetting the one who is handling it. The peculiar effects of this sprinkler are obtained by means

of several chambers one above the other. While the pressure in the first chamber is sufficient to carry the water to the farthest side of the lawn, in the last chamber it is only sufficient to throw the streams of water a few inches.

### New Kind of Lawn Sprinkler

A NEW kind of lawn sprinkler which has won favor in California is now being introduced in the eastern states. This sprinkler will apply water to every square inch of any round, square or oblong lawn without being moved and the edges of the stream will be so straight-cut and even that scarcely a drop will reach the sidewalk. In other words, this sprinkler will throw a solid

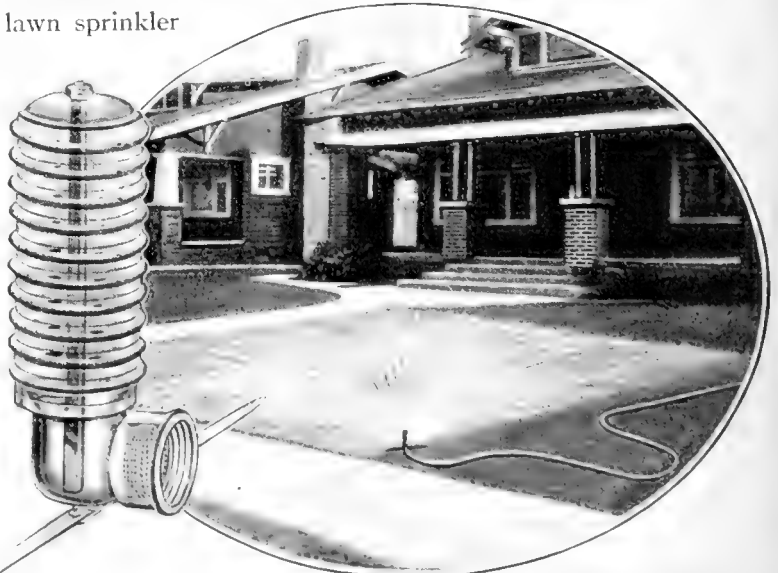

The Water Issues from Perforations in Graduated Chambers of the Sprinkler Which Confine the Area of the Spray



# Loading Guns by Pneumatic Tube

FROM the days of the Spanish Armada down to the present time guns, big and little, on board men-of-war have been loaded by hand. Ammunition hoists have supplanted the tedious lifting processes of the past, but modern engineering progress seems to have left in the lurch any instrument which would automatically load the gun and thus do away with the human factor. However, a Massachusetts man has taken out patents on a pneumatic ammunition elevating and loading device which may solve the problem.

His device is particularly adapted for use on shipboard, and the object is to provide means under the control of the operator in the turret for elevating a charge from the magazine to the turret and to direct and drive the charge into the breech of the gun for firing, after the breech has been closed. The mechanism as installed would extend from a point adjacent to the magazine below the deck to a device located above the gun deck.

The complete elevating and loading system consists primarily of a transmission tube adjacent to the magazine which leads directly to the breech of the gun. The tube's lower section or despatching inlet is so adapted that two holders comprising the inlet may be brought into alinement with the tube by moving a lever fixed to the inlet. The air is supplied through a pipe which connects at one end with a reservoir where the supply of air is stored, and

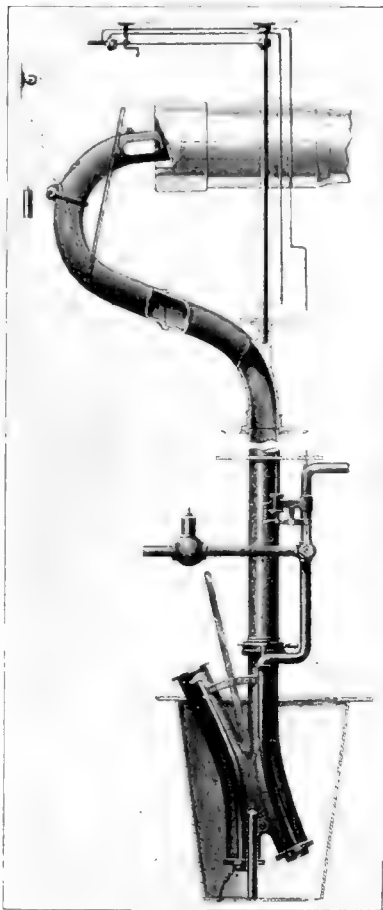

The Bend of the Tube Is Important as a Retarding Device to Deliver the Ammunition Gently and Without Shock into the Breech

which will always be at constant pressure prior to sending a charge. As each holder is swung into position, or alinement with the transmission tube, an airtight joint is made. When one holder is connected with the transmission tube and the charge is ready to be elevated to the gun, the other holder is in a position to receive a fresh supply of ammunition.

Above the gun deck the main or transmission tube is pivoted at its lower end so that it may be swung to connect with either of the guns near it. The tube is curved to form a bend by which the ammunition is carried round to the breech of the gun and delivered horizontally into the gun.

When the tube is in position to deliver into the gun it is held firmly in position by means of a lever. A counterbalance connected with the tube sections facilitates their movement and holds them in any desired position. Within easy reach of the gunner is a valve which is operated to allow the charge of ammunition to be driven into the gun, but an automatic device makes this impossible unless the transmission tube is in alinement with the breech of the gun. A system of valve connections makes this possible.

By means of them the man in charge of the magazine will be unable to send any ammunition until the gunner is ready to receive it. When the gunner is ready he will turn the valve above his head which will allow the man in the magazine to send up the ammunition.



### Bagging Rivet Heads with a Butterfly Net

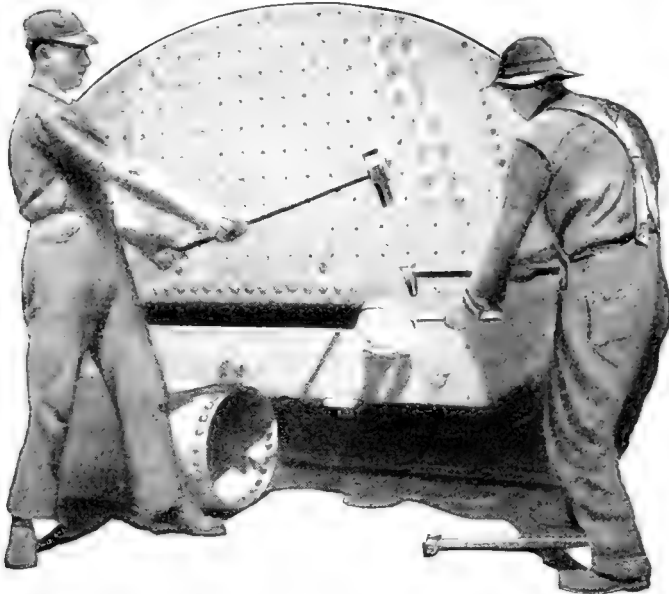

The Metal Chips and Heads of Rivets When Cut Off Are Caught in Wire Baskets with Wooden Handles

**C**UTTING off rivet heads is a strenuous occupation. Bits of metal are likely to fly in unlooked-for directions, sometimes injuring bystanders very severely.

Safety engineers on the Southern Pacific Railroad figure that loose rivet heads flying around with the speed of bullets are not conducive to the general good health and well-being of employees or of the public.

Hence they have equipped all their rivet-cutting gangs with wire baskets mounted on long wooden handles. When using one of these devices, a rivet-cutter angles for the head when it comes off in much the same way as entomologists and youngsters seek to capture moths with butterfly nets—in fact, the rivet baskets and a professor's butterfly net look a good deal alike.

At any rate, the baskets have proved themselves to be a sure preventative of flying rivets; for they catch their prey before it has flown six inches—thus effectually stopping them in their dangerous flight.

### Hungarian Nectar Still in Which Rhubarb Brandy is Made

**I**N the Pittsburgh office of the Federal Revenue Department there is an apparatus which might be called a home-made moonshine whiskey outfit if it had not been designed to distil drop by drop the Hungarian nectar known as "rhubarb brandy." The Hungarians drink rhubarb brandy with as much pride and genuine enjoyment as the Italians display when wrestling with spaghetti.

As the rhubarb brandy is supposed to be possessed of medicinal and health-building qualities, being laxative in its action rather than abnormally stimulating in its effects, those who hold it in high regard may object to its being classified with whiskies in general.

However, it is made in much the same way.

The still by means of which the brandy is made is a copper kettle sealed at the top with the customary "goose neck," and it was confiscated as illicit.

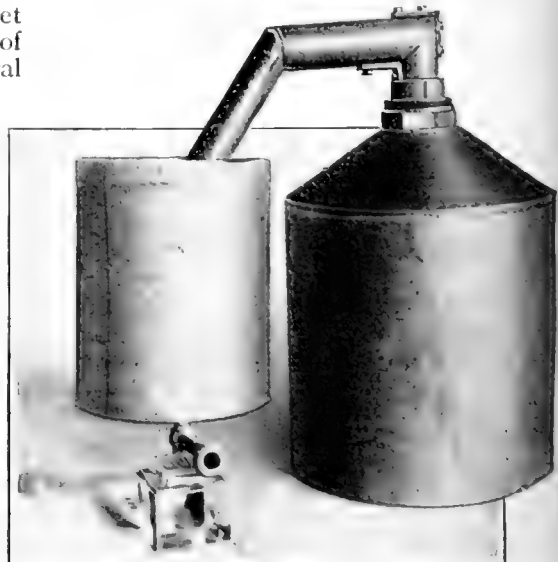

The Copper Kettle Outfit Which Distills the Rhubarb Brandy Drop by Drop

# A One-Eyed Machine Stenographer

**I**N the July number of the POPULAR SCIENCE MONTHLY we described a typewriter operated by the human voice. Mr. John B. Flowers, of Brooklyn, N. Y., the inventor, has devised another machine, which is nothing more or less than an "eye-operated typewriter."

On top of this new machine is a huge round ball. That ball is a mechanical eye—equipped with a lens and a retina just like the human eye. Hold a typewritten sheet of paper up in front of that eye, and it "sees" it, even as all of us would.

Unfortunately, perhaps, that eye can not turn in a socket like ours, so it rides to and fro on the typewriter carriage instead, the lateral motion of the carriage causing the eye to progress from one word to the next of the line of print which it is mechanically copying.

When the end of the line is reached and the eye can not see anything but blank paper ahead, like a sensible being it sends

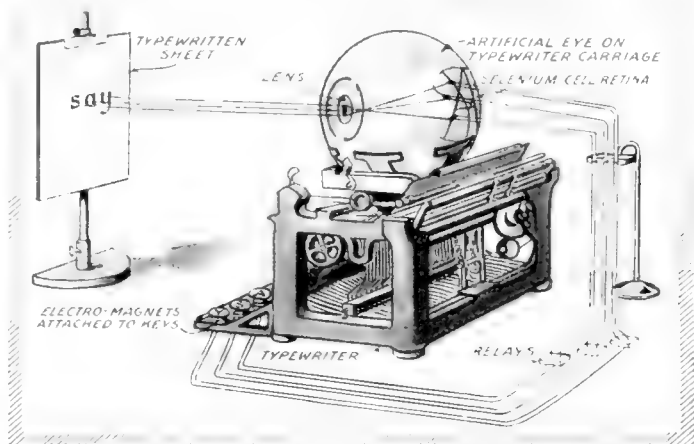

The Typewriter Operated by the Mechanical Eye. The Huge Round Ball on Top Is the Eye. It Happens at the Moment To Be "Looking" At the Word "say" on the Sheet of Paper at the Left. As the Eye Rides Along on the Typewriter Carriage the Separate Letters of "say" Fall on the Eye's Retina in Succession. Selenium Cells Are So Mounted in This Retina that the "S," "A" and "Y" Each Has a Cell of Its Own, So Placed That the Image from No Other Letter Than the Right One Can Affect It. In This Way the Word "say" Is Copied

an impulse down into the inner workings of the machine to shift the paper ahead one line, and to move the carriage back to the other end of its track to start anew—which both paper and carriage promptly and obediently proceed to do.

The eye depends for its properties upon a number of selenium cells. These are so arranged that each one can be affected only by one letter out of the alphabet. The inventor of this remarkable contrivance has already succeeded in getting it to work satisfactorily on simpler letters. The ordinary business man has probably never thought that the time would come when he would have a one-eyed stenographer in his office, and a mechanical one at that, but apparently that time is not far off, if the invention works out as well as it promises.

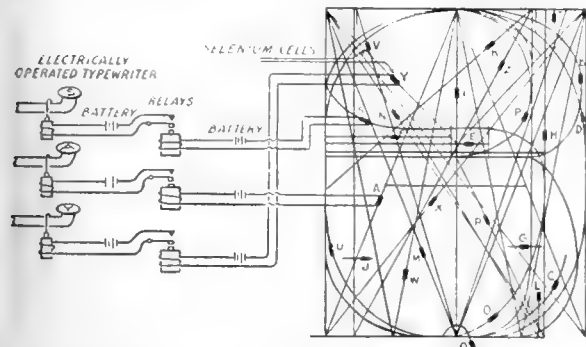

Diagrammatic Representation of the Mechanical Eye-Operated Typewriter. The Complicated Figure at the Right Represents All the Letters of the Alphabet Placed One on Top of the Other. Trace It Through Carefully and Each Separate Letter May Be Picked Out. The Small Black Rectangles Placed One on Each Letter Represent Selenium Cells. This Whole Arrangement Is Placed in the Back of the Mechanical Eye and Is Connected with the Keys

# Making Artificial Eyes for Blinded Soldiers



The Artificial Eye Maker First Takes a Tube of Glass, Heats It and Blows It Until a Bubble of Glass Is Formed at the End. The End of the Bubble Is Then Perforated With a Conical Point As Here Shown. Thus the White of the Artificial Eye Is Formed. The Iris, Appropriately Striated, Is Then Fused to This Bubble



Blowing a Bubble of Glass. After the Iris Is Made It Is Soldered to the End of the Sclerotic, or the Imitation White of the Eye Which Encloses the Eye Ball. The Whole Is Then Tinted in Exact Similitude to the Natural Eye

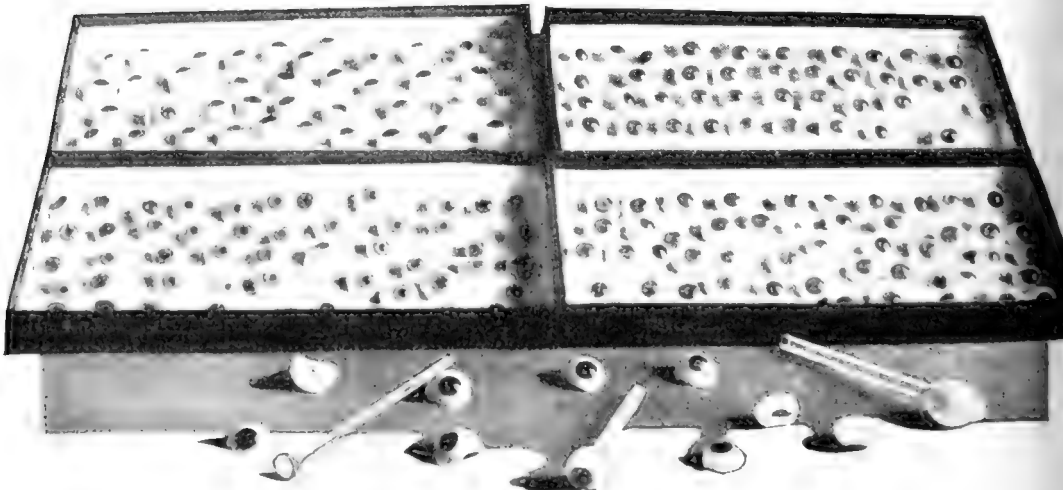
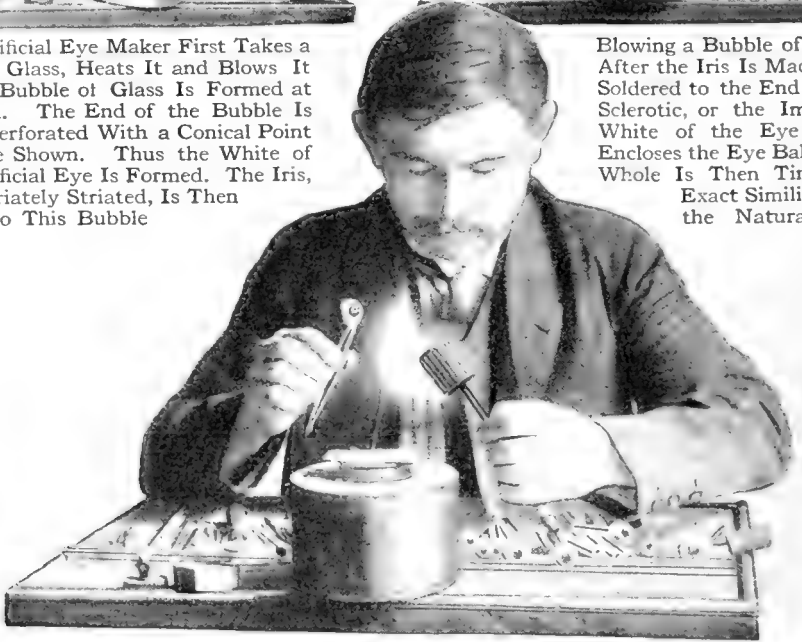

## A Twelve-Inch Gun of French Make

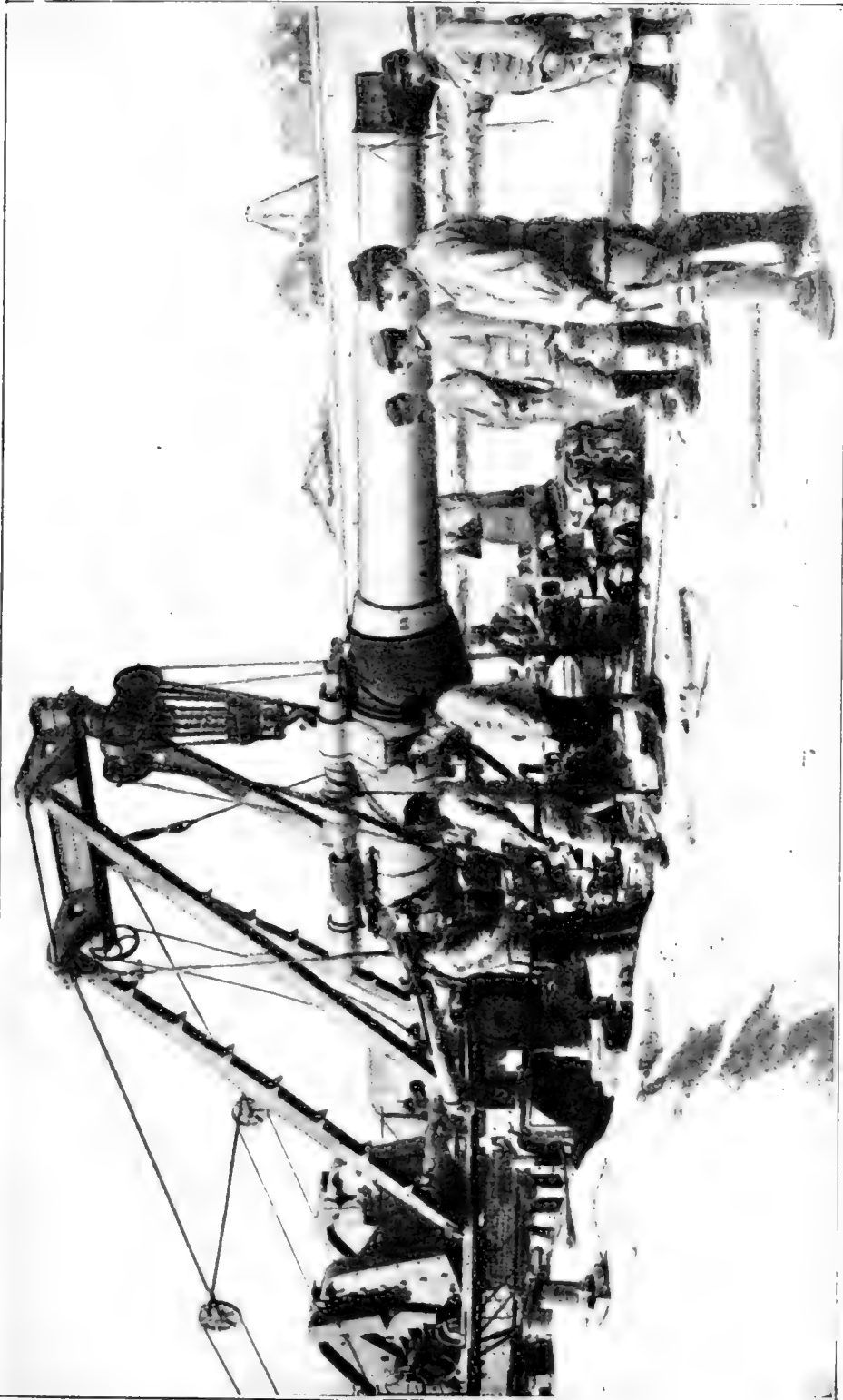

When Big Guns Are Mentioned One Immediately Thinks of Germany and the Havoc Wrought by Her "Big Berthas" and Her 4.2 Centimeter Howitzers. France, However, Has Come to the Forefront with Big Guns of Her Own Which Have Played an Important Part in Her Defensive Warfare. The Illustration Shows a 12-Inch French Gun Being Hoisted Into Position for Dealing Destruction in the Great War Game

## Britain's New Idea in Dirigibles

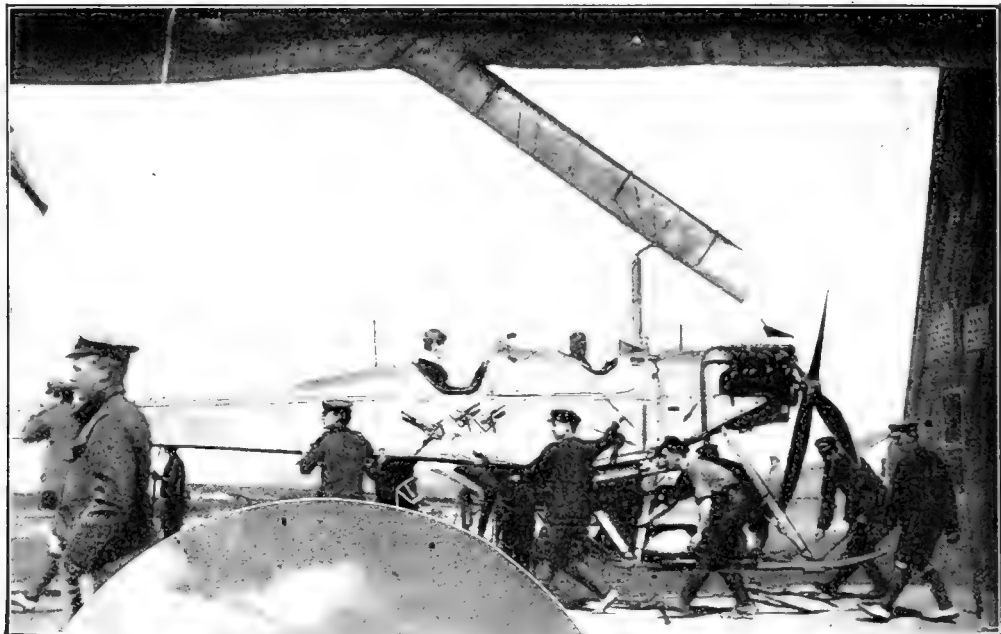

The New British Dirigible. Note the Stiffened Hose, Up Which Air Is Forced by the Tractor Screw, Distending the Gasbag and Keeping It Inflated in a Cigar Shape

At Left, the Same Dirigible Silhouetted Against the Sky

Below, Suspended Under the Well-Shaped Gasbag with Stabilizing Fins and Rudders Is an Aeroplane Fuselage

Photos © Underwood and Underwood, N. Y.



# Big Guns and the Havoc They Wreak



© Int. Film Serv.

A Heavy Howitzer Being Fired in France. These Men Are Firing at an Enemy They Never Have Opportunity to See. They Are Merely Automotons in the Game of War

At Right: Fort Vaux Under Actual Bombardment. Shells Are Exploding in Front of the Soldiers in the Picture. All Retreat Was Cut Off and These Men Later Surrendered



© Modern Photo Serv.

Below: Big Artillery Pieces Being Hauled to the Verdun Front by Tractors. The Heaviest Artillery Fire of This and Any Other War Has Taken Place at Verdun

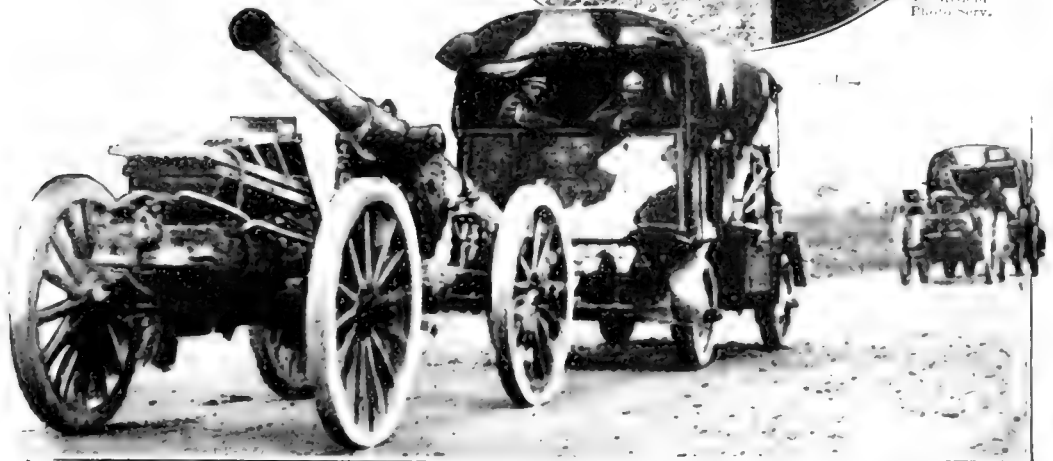

© Underwood and Underwood, N. Y.

## Interesting Snap-Shots from Verdun



© Int. Film Serv.

A Storing Place for War Material Behind the French Front. As This Material is Needed by the Men in the Trenches It is Forwarded to Them by a Light Railway



C. Press  
Illus. Co.

At Left, German Soldiers Measuring the Distance or Obtaining the Range Before Firing Upon Hostile Aircraft. In Such an Apparatus the Aeroplane and Dirigible Find Their Most Dangerous Enemy

Below, a Temporary Shelter on Wheels Constructed by the German Troops for the Convenience of Their Officers. Needless to Say the Officers Have Had Enough Engagements at the Trenches to Keep Them Occupied and Are Entitled to Their Rest





# Along the Line of March of the Various Armies



Sengalese Troops Distributing Rifles to the Recently Arrived Russian Troops at Marseilles. Russia Has Now Added Many Seasoned Thousands to the French and English Forces Entrenched Along the Western Front. The Scarcity of Ammunition Is No Longer a Drawback

© Int. Film Serv.



A Giant Buoy Which Ran Ashore on the Belgian Coast. It Was Used to Support Part of the Wire Netting Barrier Strung Across the English Channel to Entangle Submarines



## Sending Ammunition to the Mountain Tops



© N.Y. Photo Service

Carrying Ammunition to the Top of the Vosges Mountains by a Cableway Especially Constructed for the Purpose. At This Point the Mountain Is Roadless and the Cable Was an Absolute Necessity. Such Cableways Have Long Been Used by Mining Engineers

# Nursing the Wounded Chargers

A British Veterinary Traveling Hospital in France Which, Though Small, Is Fully Equipped. There Is a Special Staff Whose Sole Duty Is to Attend to the Ills of the Animals

Photos © Int. Film Serv.

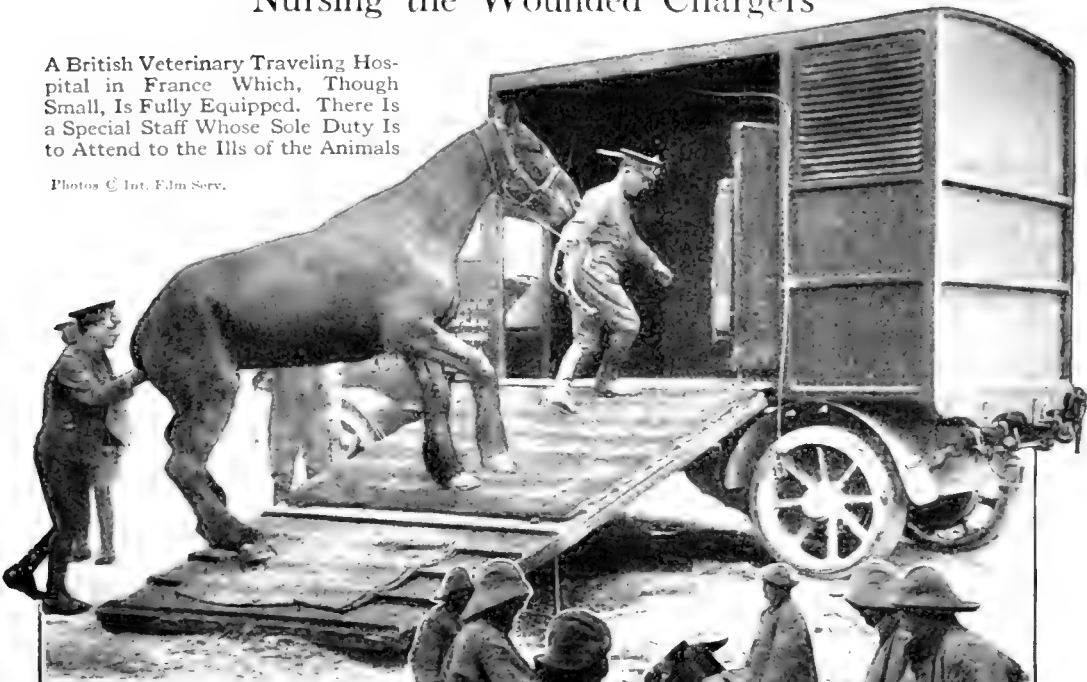

The Horse at the Right Has Contracted a Skin Disease. It Has Just Emerged from a Warm Disinfecting Bath and Is Being Diligently Scrubbed with Long-Handled Brushes



Below: the Veterinary Hospital Staff Performing an Operation on a Patient Under Chloroform. In This Picture the Operating Table Is Mother Earth and the Operating Room All Outdoors



## Shells and Guns for Verdun



A French Ammunition Depot. Thousands of Cases, Each Containing Fifteen Shells, are Held in Readiness to Be Rushed to the Battle Front



Photos © Underwood and Underwood, N. Y.

Working to Save Verdun. French Soldiers Hitched to a Three-Inch Trench Gun Take up Their Positions in the First Line of Trenches. The Love of Frenchmen for France Has Been Well Demonstrated in the Defense of This City

## Even War Has Its Sports



A Game of Nine-Fins Behind the Fighting Lines. Empty Shells Take the Place of Wooden Pins but the Photographer Does Not Say Whether the Ball Is a Cannon Shot or Not

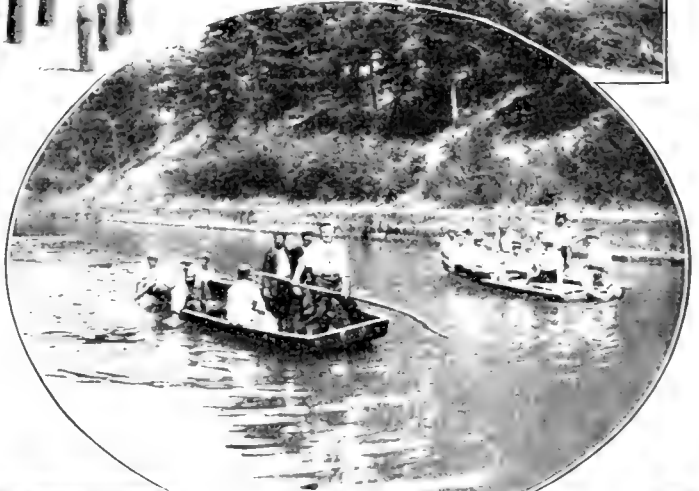

At Right: A Sail Down a River That the Censor Does Not Care to Mention. The Boats Are Improvised Rafts and Where the Usual Paddles Are Not Provided Human Hands Take Their Place



Ferrying Across a Flood Stream with What Was Once a Good Washing Tub



A Few Hours Peaceful Angling for Fish Beyond the Smell of Exploding Powder

# Introducing Law and Order Into Mexico

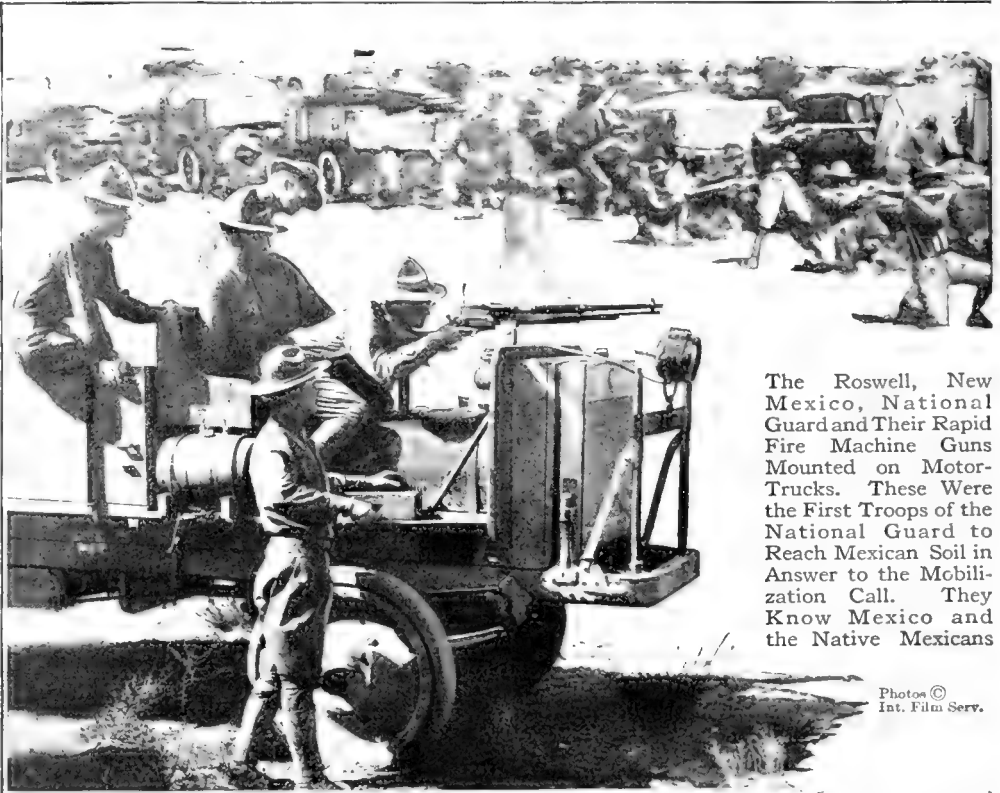

The Roswell, New Mexico, National Guard and Their Rapid Fire Machine Guns Mounted on Motor-Trucks. These Were the First Troops of the National Guard to Reach Mexican Soil in Answer to the Mobilization Call. They Know Mexico and the Native Mexicans

Photos ©  
Int. Film Serv.



A Detachment of Our Troops Entering the Wastes of Mexico, the Country That God Made Last, as One Trooper, Who Was Probably Homesick, Described It in a Letter Home

## With Motor-Trucks and Ammunition

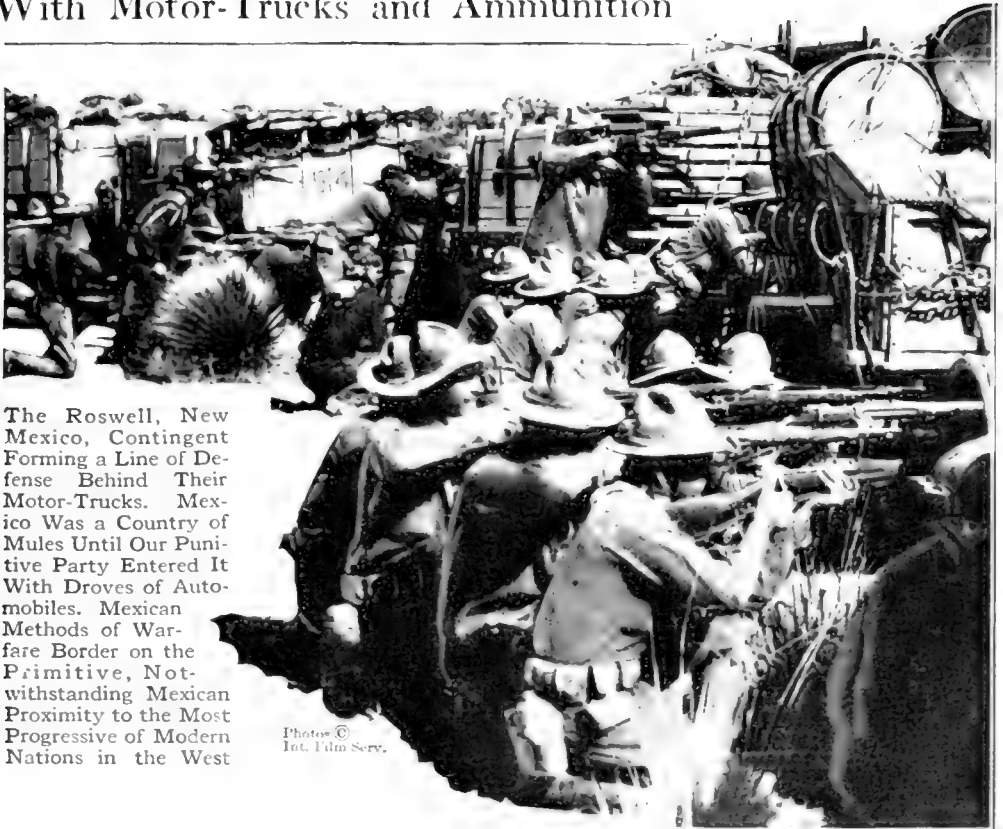

The Roswell, New Mexico, Contingent Forming a Line of Defense Behind Their Motor-Trucks. Mexico Was a Country of Mules Until Our Punitive Party Entered It With Drove of Automobiles. Mexican Methods of Warfare Border on the Primitive, Notwithstanding Mexican Proximity to the Most Progressive of Modern Nations in the West

Photos ©  
Int. Film Serv.



Great Stretches of Barren Land with Sage Brush and Sand, a Merciless Sun and a Thirst That Is Never Satiated—That Is What Our Troopers Will Remember About Mexico



# Our Standing Army's Enforced



Photos © Int.  
Film Serv.

A Temporary Camp Made on Villa's Trail, Long Since Grown Cold. Note the Hardly Discernible Long Line of Automobiles Bringing Up the Rear of an Advancing Column. The Horses Require Frequent Rests in the Desert

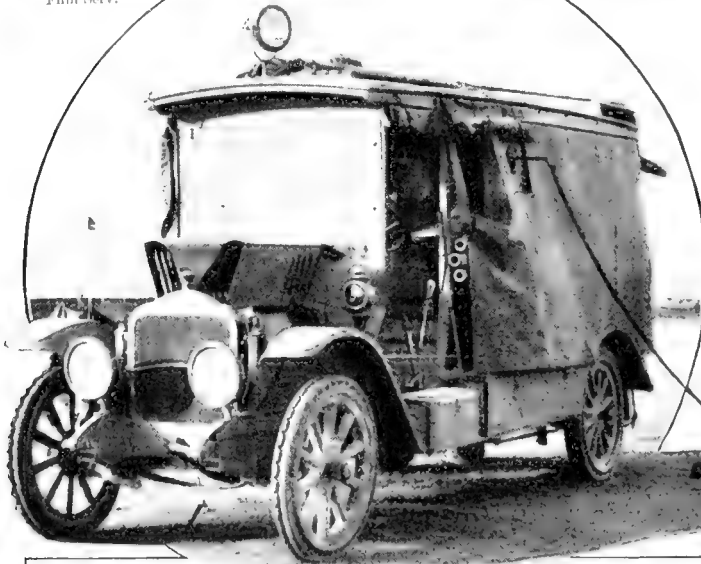

At left, A Modern Wireless Station on Wheels Is Stationed at Namiquipa. From This Station Has Come Most of the News Concerning the Advance of Our Men Who Are Now Several Hundred Miles in the Interior



Enjoying the Most Valuable Thing in All Mexico—a Bath. Such a Luxury Is About as Rare as Lobster Salad with Tomatoes and Lettuce as a Side-dish in the Army Rations



## Two-Months' Vacation In Mexico



This Camp Formation Was Used by the Indians and Our Earliest Settlers. First Come the Wagons as a Barricading Wall, Then the Horses, and on the Interior the Men and Ammunition Stores. Fighting Is Done from Behind the Wagons as Fortifications

At Right: The Captured American Troops Returning to Native Soil After the Fight at Carrizal, Which Nearly Brought on Another Mexican War. It Was the First Real Opposition to Our Troops Offered by the Carranzistas



Photos © Int. Film Serv.



A Detachment of Our Coast Artillery Using Bales of Hay as Breastworks. The Real Fighting So Far Has Been Done in the Open Without Protection of Any Kind

# Bringing Dye Stuffs to America from Germany

The Deutschland Is Not a New Type of Submarine. She Is Simply an Enlargement of the Standard German Submersible Torpedo Boat. The United States Has Decided That She Is a Merchantman and That She Could Not Be Converted Into a Warship Without Extensive Structural Alterations

The Deutschland Brought Over a Cargo of Dyes Said to Be Worth Nearly a Million Dollars and Insured for a Sum Which Would Be Considered a Comfortable Little Fortune for the Average European. Her Maiden Voyage Paid for Her Construction and Left a Handsome Profit Besides for Her Owners. She Is the First of a Cargo-Carrying Fleet



To the Left, Captain Koenig Who Goes Down in History as the Commander of the First Cargo-Carrying Submarine to Make the Trip Across the Ocean

Below, the "Bridge" and Conning Tower of the Deutschland. The Construction Is Entirely of Steel, Not One Inch Being Conceded to Decoration

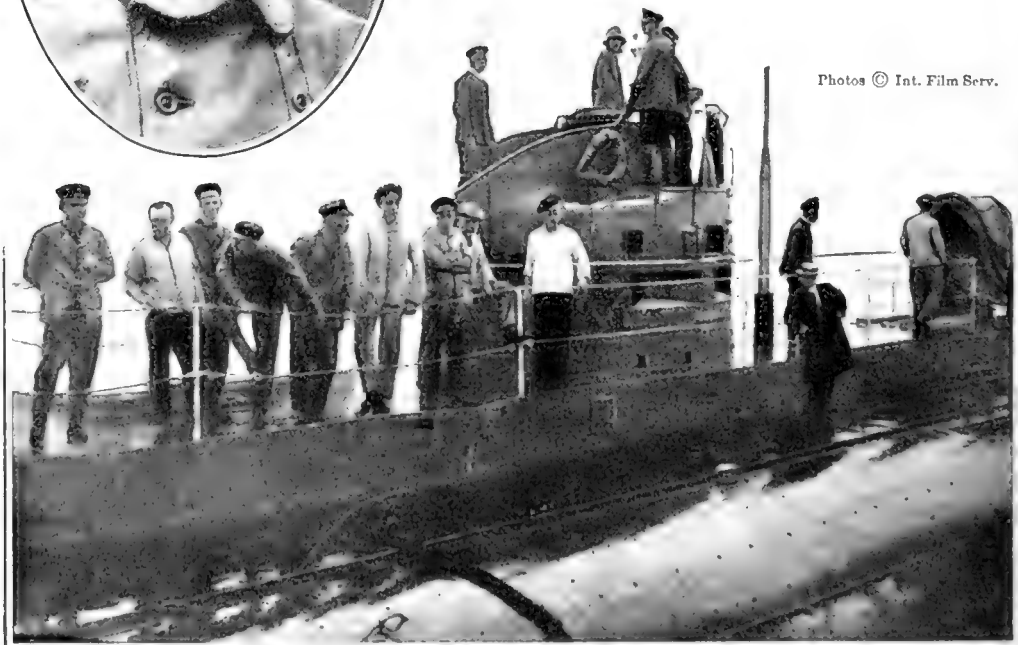

Photos © Int. Film Serv.

Part of the Crew. They Do Not Look as Though Their Recent Achievement Counts for Much in Their Estimation Since It Carried Them Out of the Excitement of the War Zone

## Via the Famous Submarine "Deutschland"

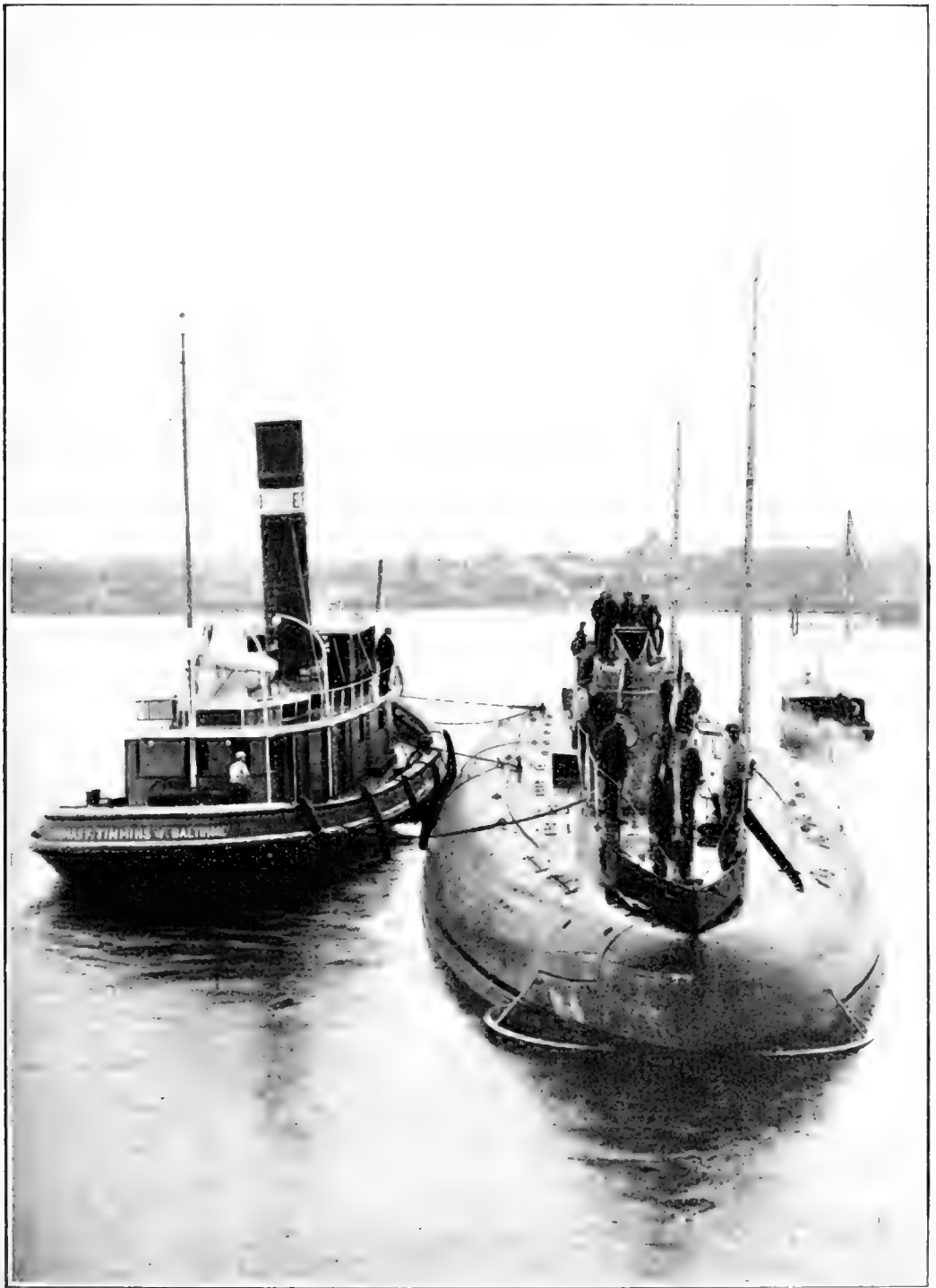

© Int. Film Serv.  
Looking More Like the Familiar Whale-Back Than Anything Else, the "Deutschland" Made Her Way into Baltimore to the Astonishment of the Entire World. She Is Three Hundred Feet Long and Therefore Smaller Than the Enormous Craft Which Rumor Had Taught Us To Expect

# The Paving Blocks of Paris

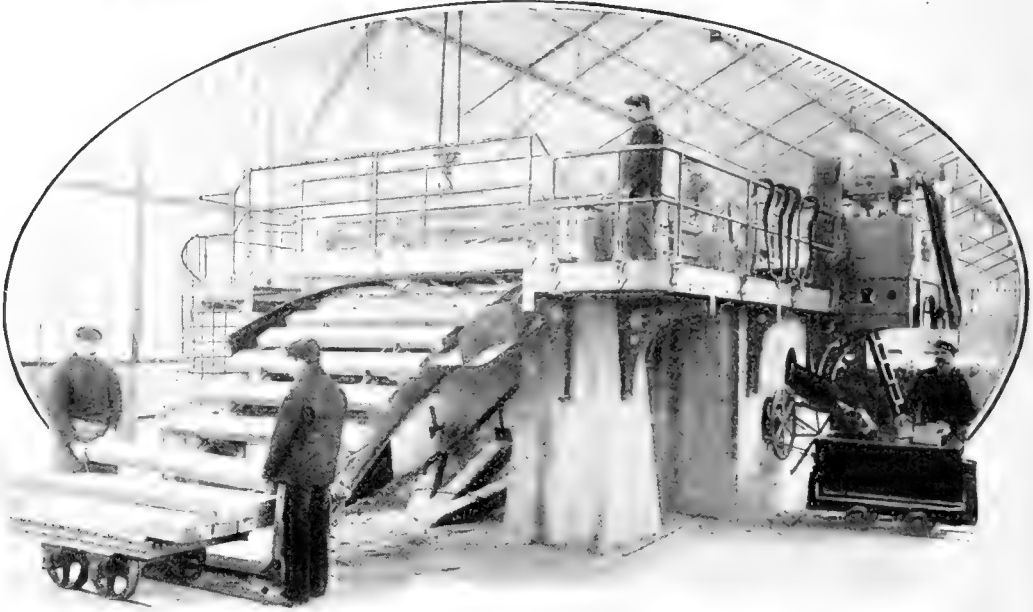

An Important Part of the Machine Is a Conveyor Which Supplies the Timbers

**L**IKE many another modern city Paris is paved in part with wooden blocks. The municipal workshop has to supply twenty-five million blocks a year. A large amount of blocks must be kept in stock because the supply of wood is not constant.

It was consequently necessary to construct a machine that could turn out the desired amount of paving a year while subject to these interruptions of supply. This was done by a M. Josse who produced a wood cross-cutting machine with seventeen circular blades that can make two hundred and forty thousand wooden paving-blocks in a day of ten hours. It economizes both wood and labor. Twenty workmen can run it.

The important part of the machine is a conveyor which is held in a frame which can be swung up or down. Two endless belts carry a series of fingers. These are mounted on bars which run from belt to belt, and there are sixteen fingers to each cross-bar. The fingers catch each beam as it comes up to the table and feed it to the saws. The saws are not arranged in just a

single row, but in several rows. One row cuts the center of the beam only; the other rows, the sides. The wood is brought by trucks to the foot of the machine where two workmen place the beams on the chain of the conveyor.

The cross-bars carrying the fingers are provided each with two little brooms to sweep off the chips and sawdust.

The saws, seventeen in number, are circular blades twenty-six inches in diameter. They are divided into three groups so as to avoid the vibrations which would result from using only one shaft of a diameter in proportion to that of the blades running at the high speed of two thousand revolutions a minute.

The first two sets of saws trim off the exterior edge of the wood and cut four blocks each; then the following set of seven saws cuts the central section of the beam into blocks. After this the blocks, drawn along continually by the fingers, pass under rollers, eventually to be pushed out by the following series of blocks. The blocks slide down a chute upon tables from which workmen take them and throw them onto small cars.

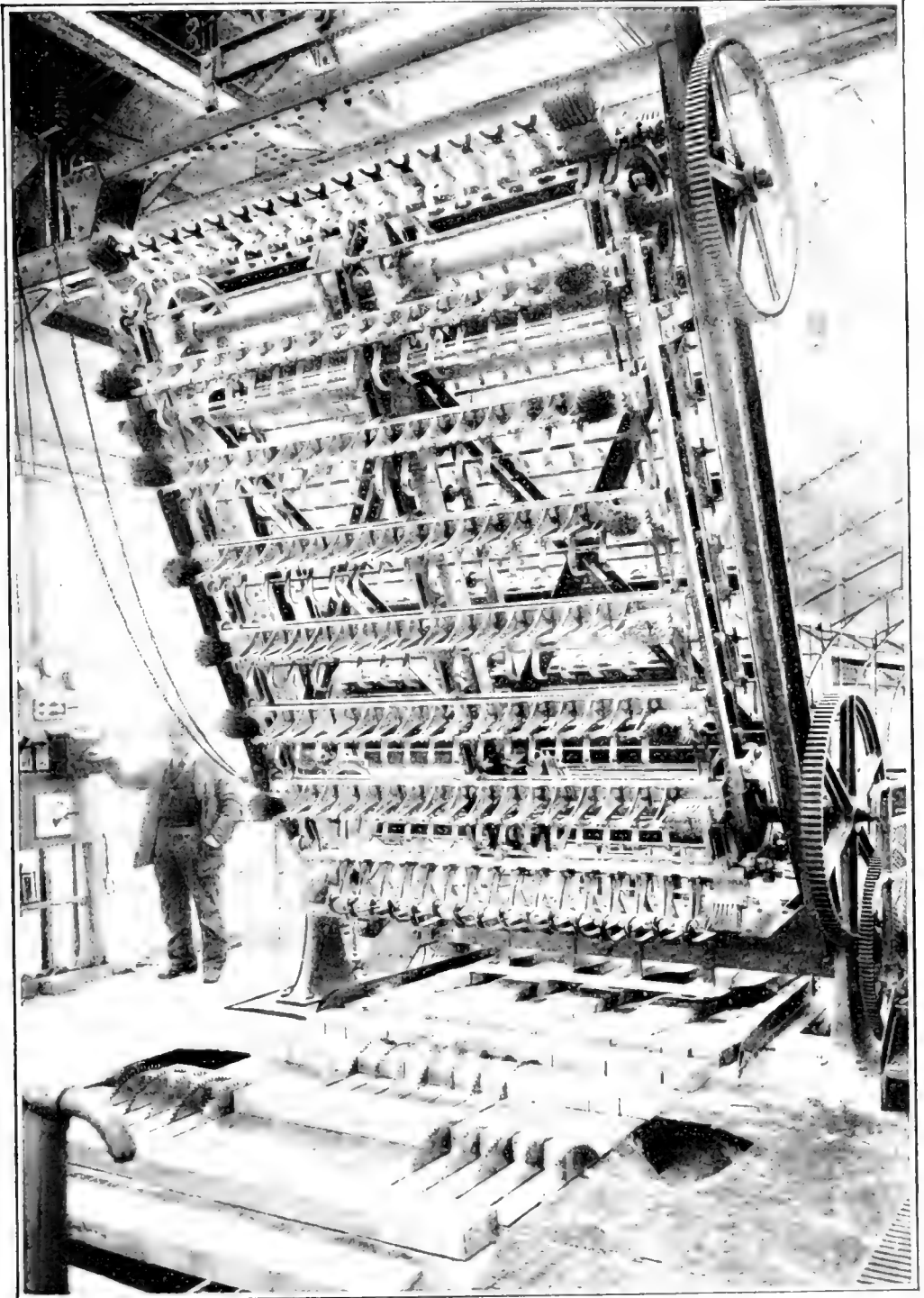

The Conveyor Raised from the Sawing Table. Two Endless Belts Carry a Series of Fingers Mounted on Bars Running from Belt to Belt. These Grasp and Propel the Blocks

### Washington Monument as a Motion-Picture Screen

**W**HAT is probably the largest motion-picture screen in captivity is claimed by the city of Washington, D. C. It is nothing more or less than the Washington monument and it has been pressed into service by the resourceful Bureau of Commercial Economics, which has decided that as long as the out-of-door public must have its cinema entertainment, it can get along without Mary Pickford and Charles Chaplin for the time being and subject itself to an educational and uplift movement.

It is the avowed purpose of the Bureau of Commercial Economics every once in a while to conduct motion-picture shows which are to

be strictly educational, and the pictures will be projected on the fair white sides of the Washington monument in the Capitol city.

The Bureau inaugurated its season by a special "invitation performance" on the evening of Decoration Day, when scenes from the Grand Canyon, the Yellowstone, the Yosemite, Crater Lake, Mount Rainier, Sequoia, and other nationally famous places were flashed against the towering shaft. A cold, wet night kept a great many away, so that comparatively few saw the monument's debut as a motion-picture screen.

On account of the monument's rough surface it was found necessary to project the pictures on a special silken screen, which a local florist provided, together with a gigantic wreath having a diameter of thirty-six feet.

The projecting apparatus was contained in a specially-designed motor-truck fitted with removable sides. An electric generating equipment for the projection arc lamp is also carried. The motor-truck was built to run from city to city throughout the east and give free demonstrations wherever possible.

The United States government loaned the films, which were made in various departments. They include, aside from scenic pictures, films showing the various activities of the government, the growth of plants from seed to blossom and seed again, the work of the forest service, and pictures of military training.



The Washington Monument as a Motion-Picture Screen. The Projecting Apparatus Is Contained in a Specially-Designed Motor-Truck Which Is to Run from City to City

**Economizing Gasoline  
for Automobiles**

**A** DEVICE called a compensating vapor plug has been designed for use on automobiles to economize gasoline. The two cone-shaped halves of the plug are divided by means of a leather washer around its circumference. At its center this washer carries a small hollow piston, the upper of which extends through the washer. A small pipe-nipple, screwed into the interior of the piston, extends down to the bottom

of the plug portion of the device which is in turn screwed into the intake-manifold. This pipe forms a clear passage between the manifold and the half of the device above the air-tight washer. The small piston is provided on opposite sides with two slots opposite similar slots in the sides of the cylinder formed by the screwing-in plug.

The lower half of the device is provided with a circular hole at one side to admit air from the outside.

The suction in the manifold draws the air out of the upper half of the device above the air-tight washer through the hollow pipe in the small piston. This forms a vacuum above the washer, making the latter assume the position shown by the dotted lines

in the cross-sectional view. As the engine speeds up, requiring a leaner mixture, the vacuum above the washer increases, causing the latter to move up still farther until the slots in the piston and the cylinder partly or entirely coincide thus allowing

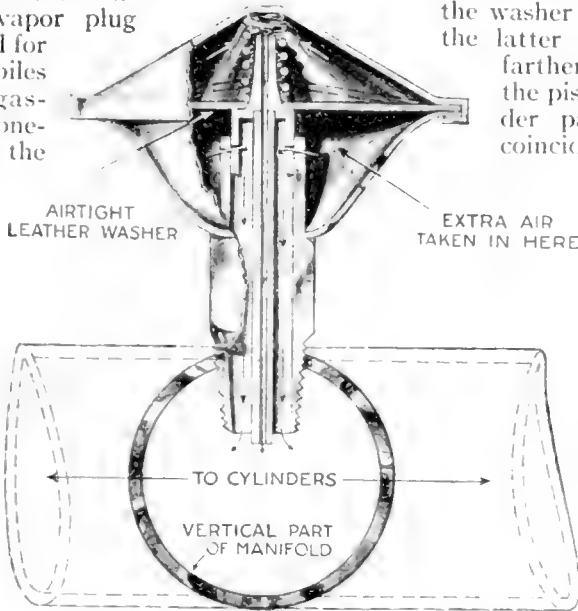

**A Compensating Vapor Plug Which Automatically Admits Additional Air to the Cylinder-Manifold**

the air in the lower half to pass down into the manifold and mix with the vaporized fuel from the carbureter on its way to the cylinders. As the suction of the engine varies according to the running conditions, the movement of the piston up and down is

such as automatically to regulate the amount of air passing through the slots according to the running conditions.

**A Shim for Adjusting Plain Bearings in Automobiles**

**F**OR use in adjusting plain bearings in any kind of machinery, the new type of shim shown in the illustration is a time and trouble-saver in that it can be peeled off to fit in a few seconds.

This is made possible by the fact that the shim is composed of laminations from 2/1000 to 3/1000-in. thick. These are forced together under great pressure and act as a solid shim, even when several layers have been removed with your thumb-nail.



**The Layers Can Be Peeled Off as Needed, the Pack Being Still Used as a Strong Solid Shim**



# Automobile Frills Which Are Making

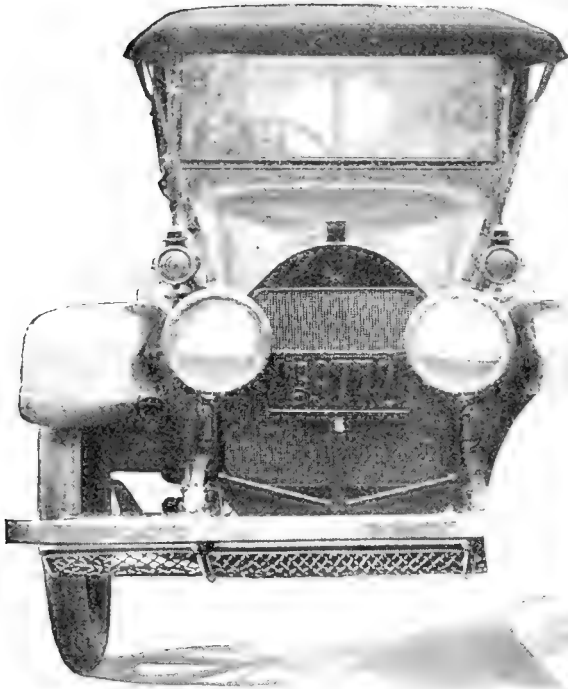

At Right: An Ingenious Headlight Dimming Apparatus Consisting of a Shutter Similar to the Camera Shutter. At Left: An Automobile Bumper Bar and Safety Fender. The Collapsible Network Sections Fold Up Like the Leaves of a Book

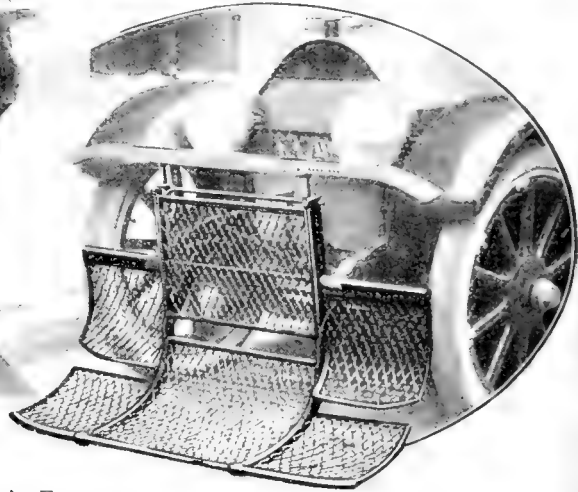
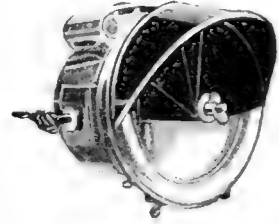

Above: When the Bumper Hits a Person the Network Drops Down Automatically and Picks Him Up and Does Not Roll or Toss Him

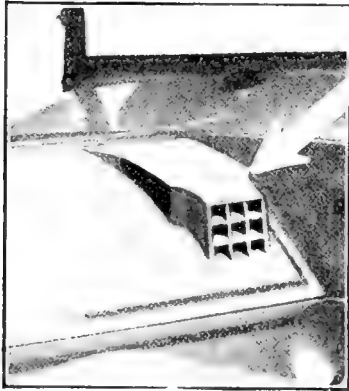

At Left: An Exhaust Ventilator to Prevent the Automobile Engine from Becoming Excessively Hot. Four Fluted Vents Are Provided. At Right: When the Automobile Is Traveling the Tubes Draw Out Air at the Rate of Twenty-Five Thousand Cubic Feet an Hour



Below: Seven Head of Cattle Were Transported Sixteen Miles Overland to a Country Fair with This Automobile Truck



# The Pleasure Car and Truck More Efficient

In Oval Below, the Top in Position. It Is Self-Supporting, Depending on the Windshield Only for a Place to Fasten in the Front to Steady It



An Auto Top That Can Be Folded Up in Thirty Seconds. It Weighs Just Exactly Twenty-Four Pounds

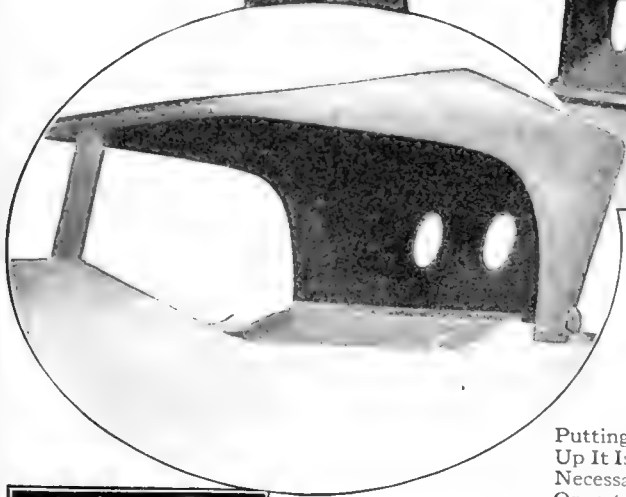

At Right Above: The Top Folded Is Carried as Hand Luggage. While

Putting the Top Up It Is Not Even Necessary for the Operator to Get Out of the Car

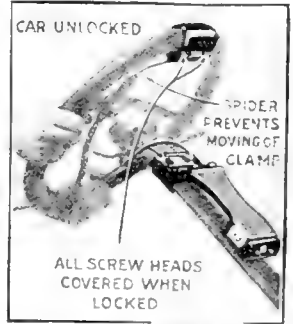

At Left, a Roll of Towel Paper Which Is Small and Handy Enough to Accompany the Automobile Man on His Trip Carrying with It a Promise of Clean Hands



At Right, a Lock That Controls Both the Spark and Throttle Levers on Ford Cars, Hooking Over One Lever and Being Securely Held to the Other by Means of a Padlock

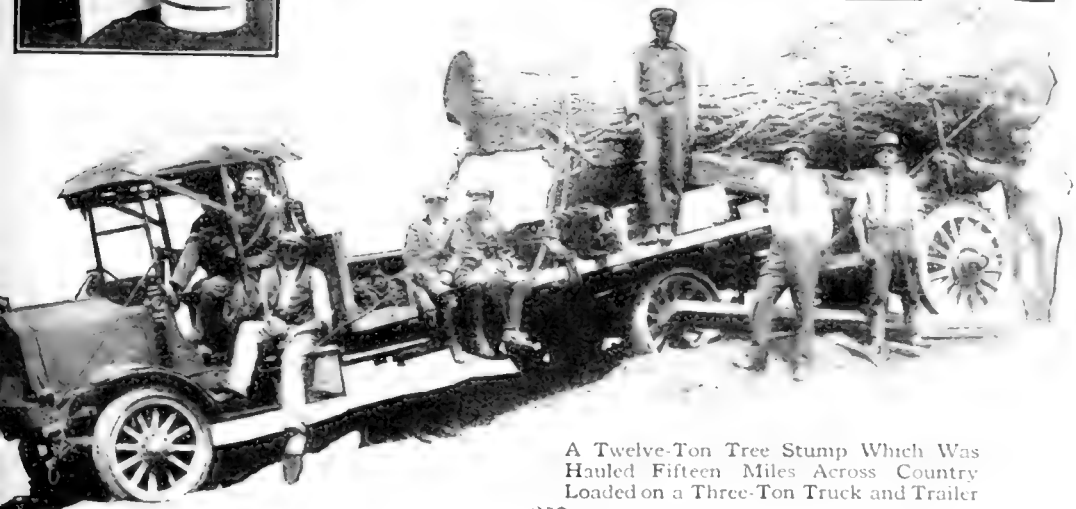

A Twelve-Ton Tree Stump Which Was Hauled Fifteen Miles Across Country Loaded on a Three-Ton Truck and Trailer

# Fifteen Motor-Trucks in One

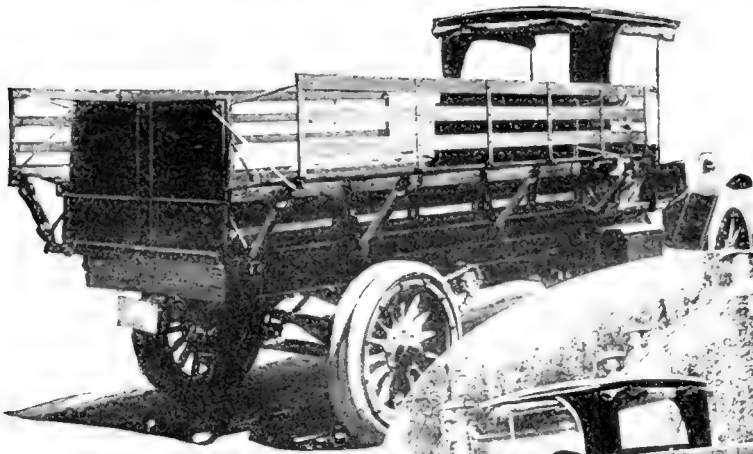
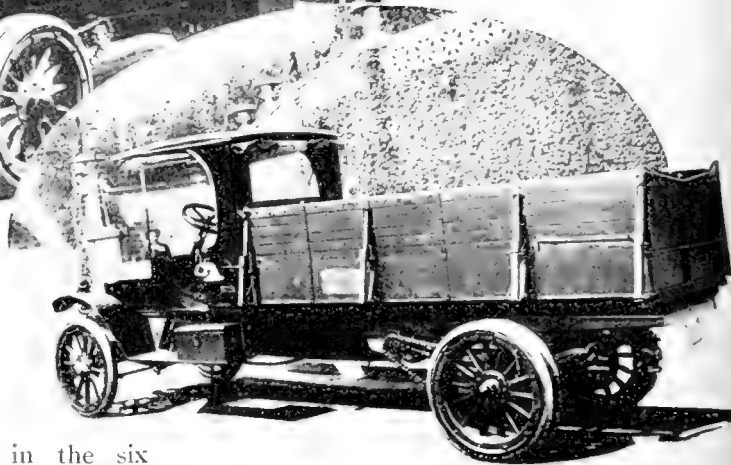

Fig. 1. The Truck in Its Normal Position, Showing in One View a Carry-All with Seating Capacity for About Twelve People. Below, the Slats Are Shown Folded Together for Carrying Grain



**T**HE FARMER may not be the only commercial man who will appreciate this manifold type of motor-truck, since the uses to which it may be put are almost limitless; but the special variations shown in the six accompanying illustrations are particularly adapted to farming.

The specially constructed body, shown mounted on a two-ton truck, is characterized by its folding sides. These are made of slats joined in much the same manner as the folding metal guards between the vestibules of railroad coaches.

The sides may be extended vertically, inclined at an angle to the bottom or laid out flat on each side to form bodies of sufficient size for carrying various kinds of farm produce. The unit is shown in

its normal position in Fig. 1, with the sides folded together to form a grain-tight body for oats, corn, bran, etc.

The sides may be extended vertically as in Fig. 2 for carrying live stock like horses or cows and hauling them quicker than they could travel themselves. Fig. 3 shows the unit with flareboard sides for carrying cob corn, potatoes or the like. Rectangular flareboards of the shelf type for holding boxes or barrels of fruits or crates of any description are still another variation of this most versatile vehicle.

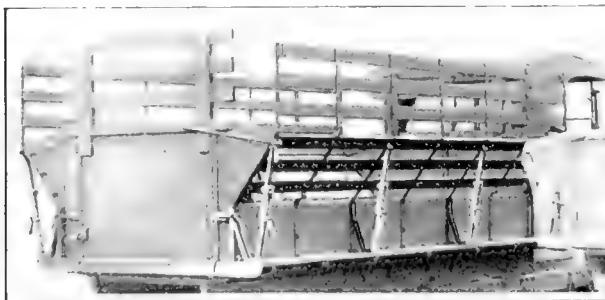

Fig. 2. The Sides of the Truck May Also Be Extended Vertically for Carrying Live Stock of Large Size, Such as Horses, Cows and Hogs

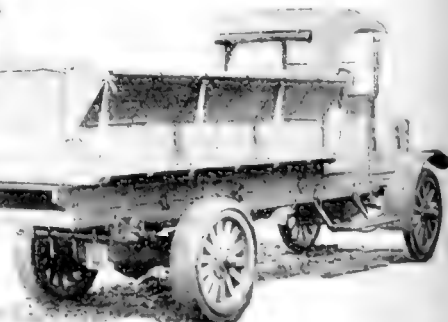

Fig. 3. The Sides of the Truck Extended to Full Height and Inclined at an Angle for Convenience in Carrying Various Kinds of Farm Products. They Will Lend Themselves to Form Almost Any Kind of Angle

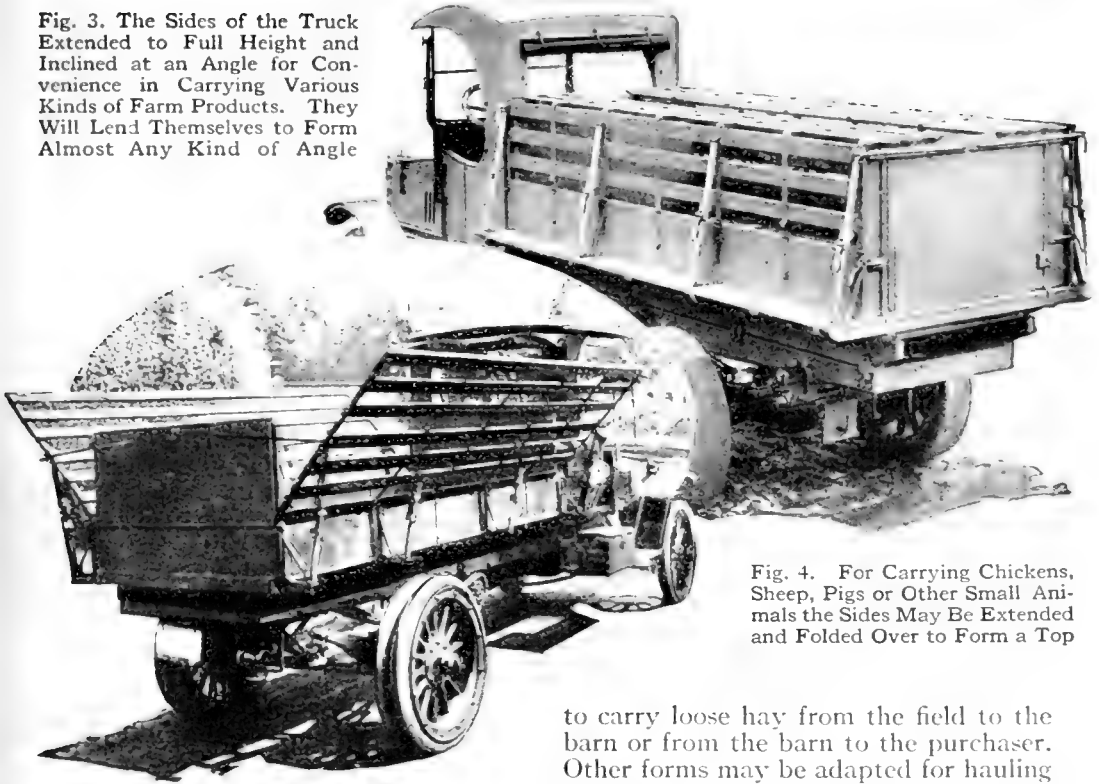

Fig. 4. For Carrying Chickens, Sheep, Pigs or Other Small Animals the Sides May Be Extended and Folded Over to Form a Top

The type for empty crates, straw and light products is shown in Fig. 5. For carrying chickens, sheep or pigs, the sides may be extended vertically for a short height and then folded over to form a top, as shown in Fig. 4, preventing the animals from getting out while being transported from place to place.

Besides the shapes pictured, the sides may be extended and folded down flat

to carry loose hay from the field to the barn or from the barn to the purchaser. Other forms may be adapted for hauling wood, cotton, and merchandise of similar character.

Another advantage of this type of body is that either one or both sides may be folded down for easy loading and unloading or for selling produce from the vehicle at the market. There are fifteen possible arrangements of the sides and ends which will suggest themselves as the occasions arise. It would require too much space to show them all.

Fig. 5. Extended Flareboard Sides for Carrying Empty Crates, Straw and Other Light Products

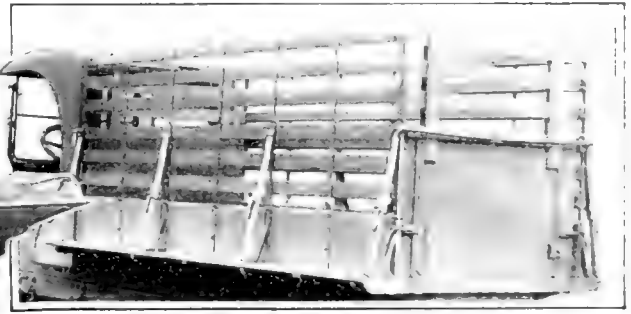
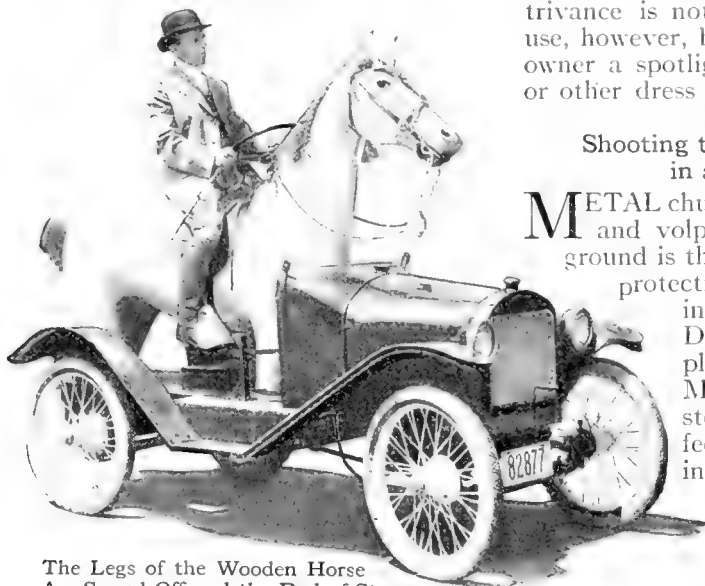

Fig. 6. Sectional Rectangular Flareboards of the Shelf Type for Boxes or Barrels of Fruits

### When the Horse Tops It Over the Automobile



The Legs of the Wooden Horse  
Are Sawed Off and the Rod of Steering  
Wheel Run up Through Its Chest

LIVES there a man with soul so dead who never to himself hath said, "What a hero I look on horseback?" Yet the automobile has its fascinations as well as its uses, and in the matter of speed and endurance it passed the horse at the first flag post. A Boston man, however, has evolved an idea for mounting a wooden horse on an automobile and getting the picturesque effect and the little tickling of his vanity without sacrificing the speed of his getting about.

The horse is a discarded harness model which was purchased for the purpose. The legs were sawed off, and the body of the horse was fastened securely to the body of the automobile. The rod of the steering-wheel was run up through the chest of the horse, and arrangement was

made for the control of the brakes and speeds in the stirrups. The novel contrivance is not intended for every-day use, however, but merely to make of its owner a spotlight favorite in a parade or other dress feature.

### Shooting the Chutes to Safety in an Explosion

METAL chutes to catch the workmen and volplane them gently to the ground is the latest device for giving protection or facilitating escape in case of explosion. At the Du Pont Powder Company's plant at Carney's Point, Maryland, there is a one-story building two hundred feet long that is constructed in sections, each being separated from those on either side by thick brick dividing walls. Should the powder "blow" in one of the sections the workmen in that particular section beat a hasty retreat to a near-by steel fence, behind which they wait.

The fire escapes are nothing more than metal chutes. If something goes wrong on the second floor and it is necessary for the workmen to get out of the building with all swiftness, they simply run for the windows, leap into the chutes, and are shot to the ground with such rapidity that others can fall in line directly behind them and never hit them.

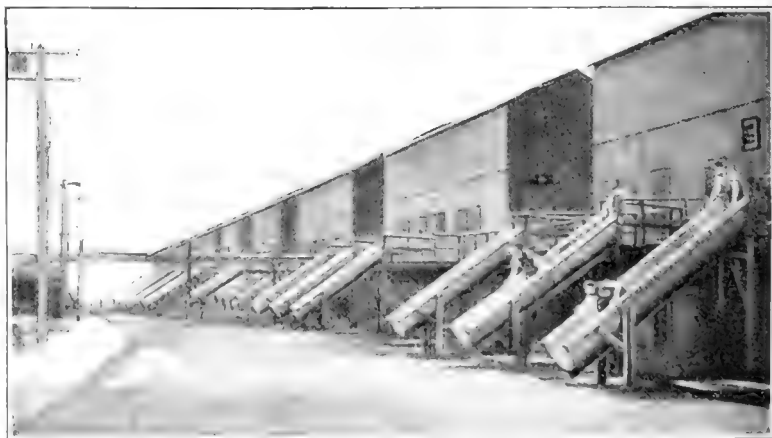

The Workmen Run for the Windows, Leap Into the Chutes  
and Slide Gently to the Ground in the Fraction of a Minute

If Your Hand Is Too Small —  
Stretch It

A NEW instrument has been invented for musicians. It is intended to be used by pianists and violinists in particular, to exercise their hands and to enlarge them. Physicians, too, will find the invention useful as a massaging device.

The instrument is fitted with grooves for finger holds which move across the board by means of elastics. Pegs set apart for the finger holds, give excellent practice for stretching the muscles of the hands, particularly those between the fingers. After a short "warming up" on this board, the musician is ready for real business.

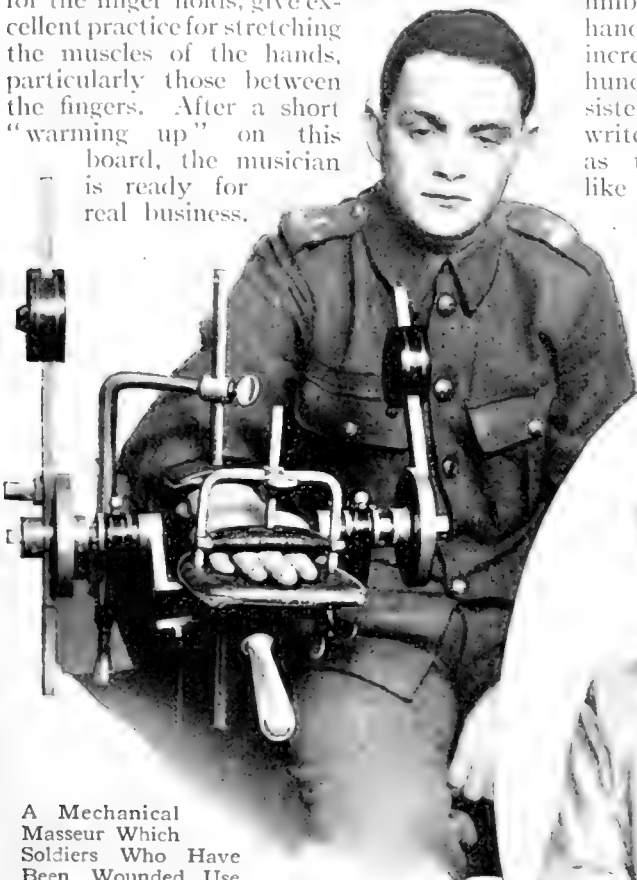

A Mechanical Masseur Which Soldiers Who Have Been Wounded Use

with a mechanical device and injured himself to such an extent that he could never play the piano so well again.

Various devices are now in general use to exercise the crippled fingers of wounded soldiers. They perform the work of *masseurs* with tireless patience and with an effectiveness that is truly astonishing. One of them is shown in the illustration on the left.

Expert typewriters and telegraphers are also adopting mechanical means for limbering up the muscles of the hands. It is said that a typist can increase her speed to nearly two hundred words a minute by persistent exercise—not on her typewriter, but with some such device as those illustrated. However, like all gymnastics, mechanical massage must be indulged in very judiciously, preferably under the direction of a professional instructor, so as to avoid all danger.



Her Fingers Were So Short She Could Not Stretch an Octave on the Piano Formerly

The instrument was also invented for the purpose of improving the structure of the hands and it is being used in the accompanying picture on the right for that purpose.

Musicians do not view these devices with unqualified approval. Unless judiciously used they may even do harm. The famous composer Robert Schumann tried to improve his hand



### A Castle Built of Coal to Advertise the Resources of Tennessee

KNOXVILLE, Tennessee, has a very practical and effective way of advertising the great natural resources of that section of the state. In Chilhowee Park, the principal recreative center of Knoxville is a veritable coal castle.

The building is constructed entirely of coal, more than a hundred tons of the mineral having been employed for the purpose, although it is only one story high with a one-room interior. The usual belief that coal is not impervious to the inroads of the elements has been very effectually disproven, because the building erected several years ago is showing no serious sign of falling into disrepair.

In addition to advertising the fact that Knoxville is in the center of a great coal producing section, the coal castle also affords the advantages of a rest room in the park. The appearance of the structure is decidedly picturesque in its glistening, weather-polished black. The building is an added attraction to the fine park.

### Cutting the Cost of Illuminants by Wall Treatment

THE illumination of factories, railroad terminals and department stores has been given great consideration of recent years; increased output, improved workmanship and a minimum of accidents having resulted in nearly every instance where better lighting systems have been installed. In such places, wall treatment as a means for conserving the illumination afforded by modern illuminants has generally been adopted. These advances have come as a result of practical observations, which show that the rays from powerful lights, falling upon dark brick or stone walls, give less light to a room than the rays from less powerful lights falling upon similar walls that have been painted in light colors with dust-resisting, washable paints. From the standpoint of economy it is of interest to record the fact that the monthly cost of illuminants for lighting dark-walled factories may be enormously reduced by the occasional application of such paints and the workers will appreciate it also.

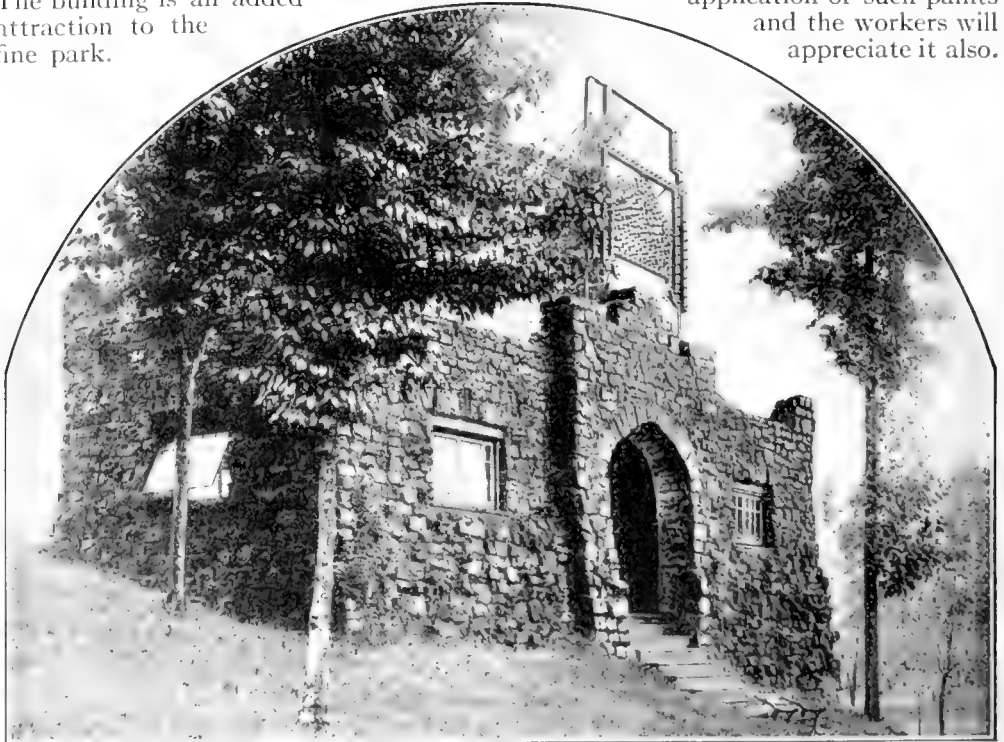

It Took a Hundred Tons of Coal to Construct This Building and Advertise the Fact That Knoxville, Tennessee, Considers Coal to be One of Her Greatest Natural Resources



Sorting and Packing Apples  
by Machinery

AN apparatus has recently been perfected which does away with the unreliable process of sorting apples by hand. Moreover, it gives the farmer an excellent opportunity to be honest, for instead of putting large apples on the top and small apples in the rest of the barrel, he can sort them according to an honest standard, and eventually get better prices, for people will learn that his large apples are large all the way down, and that his small apples don't get any smaller as the bottom of the barrel is reached.

The machine which accomplishes so accurately and simply this task of sizing involves the use of two queer looking belts which are divided up into many small segments, the segments each having a wide mouth in their center. As the belts move from one end of a flat table to the other the mouths open wider and wider, and the apples which have dropped upon the

segments, finally fall through the widening mouths. They fall at different places according to their different sizes.

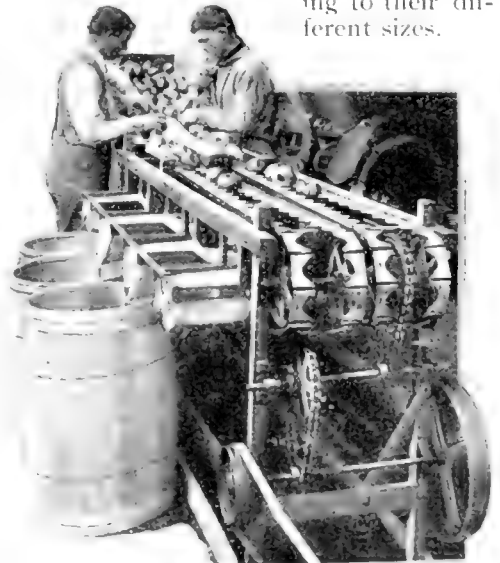

The Two Belts Are Divided into Many Small Segments Each with a Wide Mouth

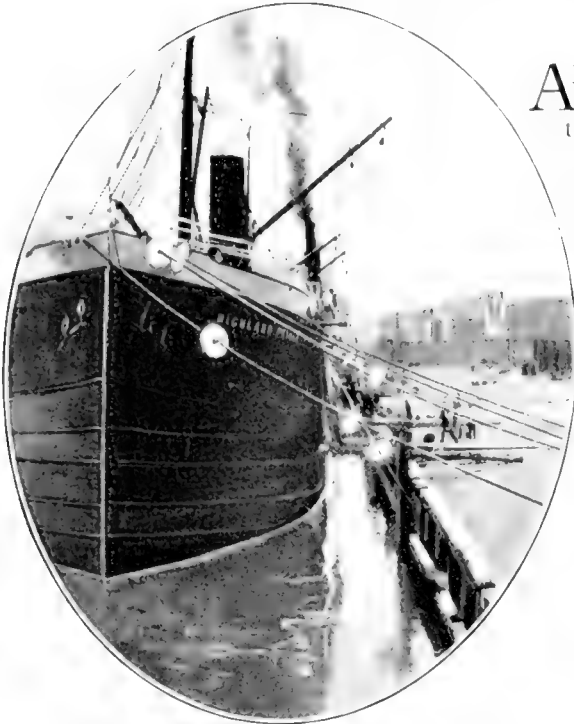

The Rat-Guard Is a Circular Disk of Galvanized Iron About Eighteen Inches in Diameter

A Guard for Mooring Ropes to Prevent  
Rats from Landing

TO prevent rats from bringing the bubonic plague into New Orleans a city ordinance requires all boats from tropical zones to "fend off" about twenty feet from the wharf and to put a rat-guard on each mooring rope. The rat-guard is a circular disk of galvanized iron about eighteen inches in diameter which keeps the rat from using the rope as a bridge and making a landing on the wharf.

In the accompanying photograph one rat-guard appears as a white circular spot near the bow of the boat. Others may be seen attached to nearby ropes. The boat at dock is the *Highland Prince* with a cargo of coffee from Brazil.

Formerly these incoming ships brought as great a cargo of rats as they carried of grain, figuratively speaking, which proved to be a nuisance as well as a grave menace to the health of the port and of the surrounding country.

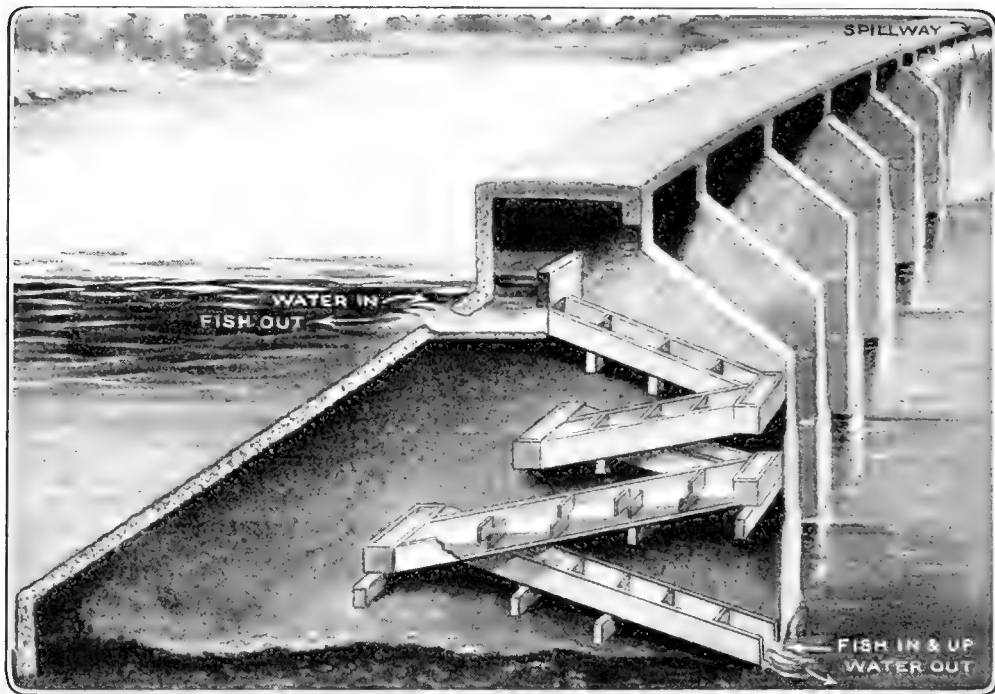

The Water in the Ladder is Continually Flowing Down and Out, Forming a Running Stream up Which the Fish May Swim, Jumping from One Pool to the Next Higher One

## How Fish Jump 100-Foot Dams

**D**O you know that fish actually jump one hundred-foot dams in their migrations each spring to the headwaters of the rivers in which they spawn? Of course, this one hundred-foot jump is not made all in one leap, but in a number of short leaps of eight inches each. This feat is made possible by what is called a fish ladder.

This ladder must be placed in all river dams in which fish such as salmon swim up to the river heads to spawn. Fish will not spawn anywhere except in the still headwaters, and it is necessary that they arrive there with the least exertion. The government makes it obligatory that at least one fish ladder be built into every dam across such rivers.

Fish ladders, while they may be built of wood, stone or concrete, according to the material of which the dam is constructed, are all alike in principle and consist of a trough which begins at water level on the low side of the dam and

then extends upward in several zig-zag steps to a point below the water level on the up-side of the stream. Water enters at the top end and flows down and out at the bottom. Its flow, however, is not free like that in a sluice, but is retarded by means of cross-pieces at regular intervals in the trough.

The accompanying illustrations show a reinforced concrete fish ladder built in the most modern type of dam of concrete construction. The cross-pieces are also made of concrete and form small pools of water between consecutive pieces. Each cross-piece is set at a slight angle to the sides of the trough, alternate ones being slanted in opposite directions. Each piece has a rectangular notch cut in the top and another in the bottom on the opposite side.

Alternate pieces have the two notches placed on opposite sides, respectively, as shown in the detailed perspective drawing. The trough being inclined, the

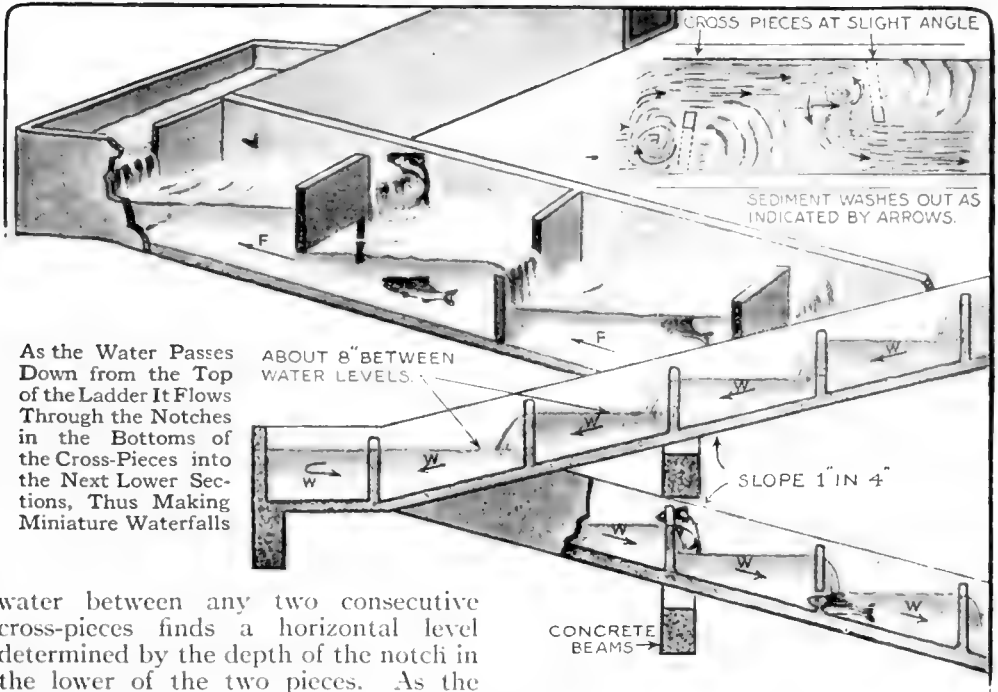

As the Water Passes Down from the Top of the Ladder It Flows Through the Notches in the Bottoms of the Cross-Pieces into the Next Lower Sections, Thus Making Miniature Waterfalls

water between any two consecutive cross-pieces finds a horizontal level determined by the depth of the notch in the lower of the two pieces. As the water passes down from the top of the ladder it flows through the notches in the bottoms of the cross-pieces and also drops over the top notches in the cross-pieces into the next lower sections like small waterfalls.

The water in the ladder is continually flowing down and out at the bottom, forming a running stream up which the fish may swim with a choice of passing from the first pool to the next and so on up by swimming through the bottom notches or jumping through the top notches from one pool to the next higher one. The jump in the latter case is not more than eight inches and can be done easily by almost any kind of fish.

It is noted in the plan view of the ladder shown in the accompanying drawings that the notches in the bottom of the cross partitions are placed at the lower end of the partitions to permit any sediment to be washed out by the flow of water. In the large drawing it is also to be noted that the ladder is not placed in close proximity to the spillway. The reason for this is that fish in trying to ascend a dam seek to pass up the largest stream of running water. Due to the fact that the volume of running water issuing from the ladder is usually less than that

dropping over the spillway, the fish would not find the ladder readily if it were close to the spillway but would try to swim up the spillway and would probably dash themselves to death against the concrete buttresses.

### Borrowing the Night Lamps of the Fireflies

Just what the secret of the firefly's light is the scientists have not as yet discovered. Three necessary factors have been found—water, oxygen and a photogenic or light-producing substance; but a fourth is probably involved which has thus far defied all research. The children say it is the fairy lamplighter whose wand lights the little lamps that add so much to the beauty of a summer's night. However, a method has been evolved of extracting and drying the light-producing organs of the firefly without impairing the power of the substance to phosphoresce.

The dried material may be extracted with water-free solvents. It is ground up into a powder, and water containing oxygen is added; which gives the golden glow without the assistance of either the firefly's will or the fairy's wand.

# Defying the Action of Fire



The Inventors Claim That All Building and Household Materials and Even Ordinary Paper Can Be Made Non-Inflammable

burned to ashes in exactly nine minutes. The flame of a Bunsen burner gives a much greater heat than an ordinary fire—from 700 to 1,000 degrees Fahrenheit. The board was slightly charred over the area struck by the flame and a hole about five-sixteenths of an inch in diameter was made, but at no time did a blaze appear. Ordinary paper, gun cotton, and other highly combustible stuffs, when similarly treated, failed to burn.

Rainfall, running water, climatic conditions and all sorts of weathering agents do not appear to affect the residue of the solution in the slightest degree. The pine board, which resisted the Bunsen burner for an hour, was placed under a heavy running stream of water for twenty-four hours after the solution had dried on it. Strips of ordinary toweling were treated with the liquid and then placed in windows and exposed to rain and dew, but this did not affect their resistance to fire. This is an improvement on fire-proofing materials now on the market, which are soluble and only serve to retard the destruction of fire.

**A** LIQUID that resists the action of fire and water and renders all inflammable materials absolutely fire-proof has been perfected in the pharmaceutical laboratories of the University of Iowa. When wood, cloth, or paper are saturated with it and then dried, an insoluble mineral material is left in the cells of the fiber which makes combustion impossible. The drying may be spontaneous, or, in the case of wood, may be done in a kiln.

As a test, a block of wood which had been soaked in the new preparation and afterward dried resisted the flame of a Bunsen burner for one hour, whereas a similar block of untreated wood was

# Exterminating Mosquitoes

**N**EXT to draining, the best way to abolish mosquito breeding places is to treat the water so as to kill the mosquito larvae and while many substances have been tried for this purpose, nothing has given such good results as petroleum, according to experts of the United States Department of Agriculture. Common kerosene of low grade is most satisfactory as regards efficiency and price.

It has been found that spraying with a portable pump is the best way to use the oil. Small ponds, however, can be sprinkled out of an ordinary watering-pot with a rose nozzle, or for that matter pouring it out of a dipper or cup will be satisfactory. In larger ponds pumps with a straight nozzle may be used. A straight stream will sink and then rise and the oil will spread until the whole surface of the water can be covered without waste.

In choosing the grade of oil to be used two factors must be considered; it should spread rapidly and should not evaporate too quickly. Heavier grades of oil will be apt to gather in

spots and the coating will be necessarily thick. It has been found that one ounce of kerosene is sufficient to cover fifteen square feet of surface, and in the absence of wind, such a film will remain persistent for ten days. Even after the iridescent scum apparently disappears there is still an odor of kerosene about the water. A mixture of crude oil and kerosene has been found to be effective in killing mosquito larvae. It has one very decided advantage over pure kerosene which is that it does not evaporate so quickly.

Special attention should be paid to little pockets of water that form around the edges of ponds, for it is in such places where the water is not disturbed by wind or otherwise that the larvae breed in greatest numbers. Larvae do not breed in open stretches of water where the surface is rippled by the wind.

In the fight against the mosquito in Panama, the government experts found that a larvicide composed of carbolic acid, rosin and caustic soda was very effective and thousands of gallons of it were used. Crude oil was employed in streams having a fair velocity.



Covering the Surfaces of Ponds and Other Breeding Places with Petroleum, According to Experts of the Department of Agriculture, Is the Best Move Against Mosquito Larvae. The Illustration Shows a Pond Being Sprinkled with Petroleum from a Portable Pump

# Raising Parasites to Fight Pests

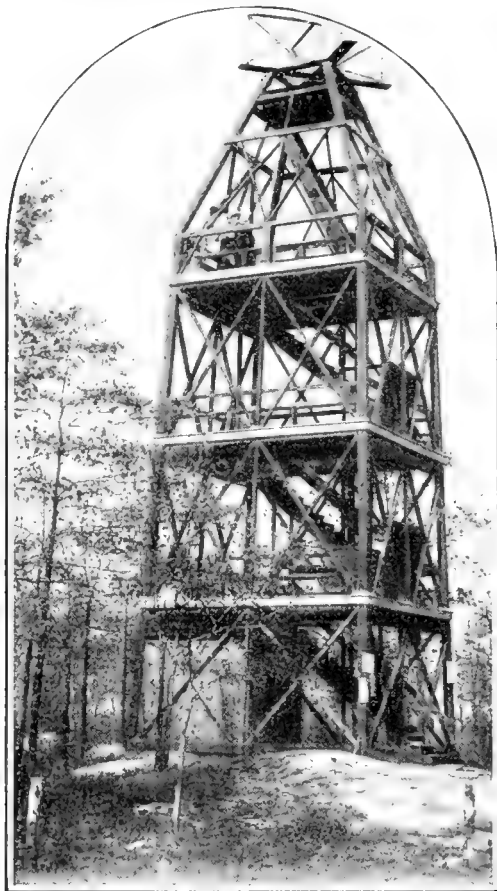

Structure Erected in Connection with the Parasite Laboratory Where the Gypsy Moth and Other Pests Are Trapped and Studied

**M**ANY methods of exterminating injurious insects have been tried, some proving useless and others, while effective, being only temporarily so. Perhaps the most scientific work yet attempted is the cultivation of natural enemies, which in time would annihilate the insects upon which they live. The gipsy moth and brown-tail moth are particularly injurious. Both are natives of Europe and were early introduced into Massachusetts, where they have committed yearly ravages on fruit and shade trees. Can no enemy which will devour them be found?

In 1905, work was begun under Federal supervision to answer that question. Dr. L. O. Howard, chief of the Bureau of Entomology, and Dr. W. F. Fiske, in charge of the Gipsy Moth Parasite Laboratory, Melrose Highlands, Mass., have expended time and energy in their unceasing efforts to rid the country of these harmful insects.

While at least a dozen parasites have been reared from the gipsy moth, and although a variety of American parasites are natural enemies, the aggregate effectiveness of all the species together is wholly insignificant. It is possible, however, that the caterpillars may be attacked by parasites, the larvae of which may be rendered unable to complete their transformations under the conditions in which they find themselves.

Since insects like the gipsy moth and the brown-tail moth are subjected to the

An Apparatus Similar to an Ordinary Show-Case, the Glass Sides Being Supplanted by Cloth in Which Sleeves Are Set Through Which the Nests May Be Handled Without Any Danger

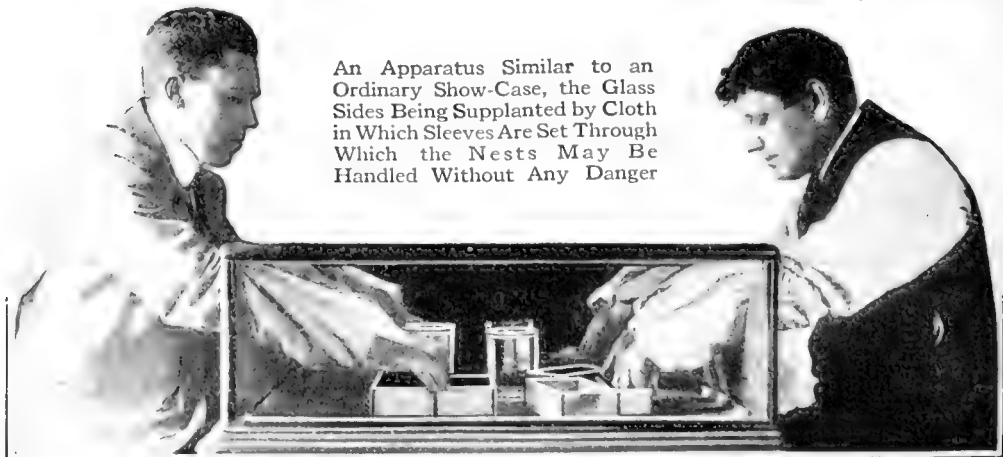

attack of different species of parasites at different stages in their development, it has been necessary, in order to secure all of these, to import the host insects in as many different stages as possible and practicable. Importations of large caterpillars, ready or nearly ready to pupate (go into a sleeping state) were first made in 1905. It was demonstrated during that year that they could be brought to America with a fair degree of success and that at least a proportion of the parasites with which they were infested could be reared.

One of the greatest difficulties, experienced from the outset, has been the acclimatization of the parasites. The ones thus far cultivated

have a tendency toward rapid dispersion over a wide area, thus hindering colonization. Even though a large number of individuals are released, their spread is so rapid that the possibility of meeting and mating is soon lost.

Perhaps the most serious handicap to the progress of the work is the preservation of the health of the assistants in the laboratory. The irritating and poisonous hairs of the brown-tail larvae, of which the nests are full, penetrate the skin of the assistants, entering their eyes and throats and almost filling the atmosphere of the laboratory. It was soon found necessary to keep the rooms thoroughly closed. Double windows were used, and the doors, too, were doubled, in order that a possible secondary parasite, if accidentally liberated, should have no chance of escape. This made the rooms very warm and increased the irritating effect of the larval hairs. Spectacles, gloves, masks, and even headpieces were invented, but they only increased the heat and were not entirely effective in keeping out the troublesome hairs.

Dr. Fiske finally devised an apparatus similar to an ordinary show case, the glass in one side being replaced by cloth with armholes, through which the gloved hands of the worker could be thrust and the brown-tail nests handled in full sight through the top glass. Much of the rearing of brown-tail larvae must be carried on under conditions in which such cases cannot be used, and so the old difficulty still exists.

It is hoped that the parasites already introduced will in time prove sufficient for the purpose intended. Only events themselves can be depended upon to answer this question. Unfortunately the moths continue to disperse and multiply in the meantime.



Spectacles, Gloves and Masks Are Worn by the Laboratory Workers as a Safeguard Against the Irritating Effect of the Gypsy Moth's Hairs

#### Why Whiskers Continue to Be in Style for Cats

**A**LTHOUGH hirsute adornments of all kinds, whiskers included, were once the real and indispensable thing, modern sanitary practice has made such inroads on unharvested beards and long hair that only a few scattered humans such as musicians and soap-box orators still retain their hairy luxuriance. Notwithstanding this, however, the house cat has grown and nurtured its crop of whiskers or feelers for the last million years or so without bothering about hygiene.

The fact is that the cat's whiskers are absolutely necessary to it. The whiskers are as long as the cat's head is wide, and the head is as wide as the body, so wherever the whiskers go there may the cat go also.

The tiny, delicate hairs grow from a gland and are nerved to the utmost sensibility. No matter how light the touch of the hair against an obstacle it is instantly felt by the cat.



### A Low Water Alarm for Boilers, Which Has No Stuffing Boxes

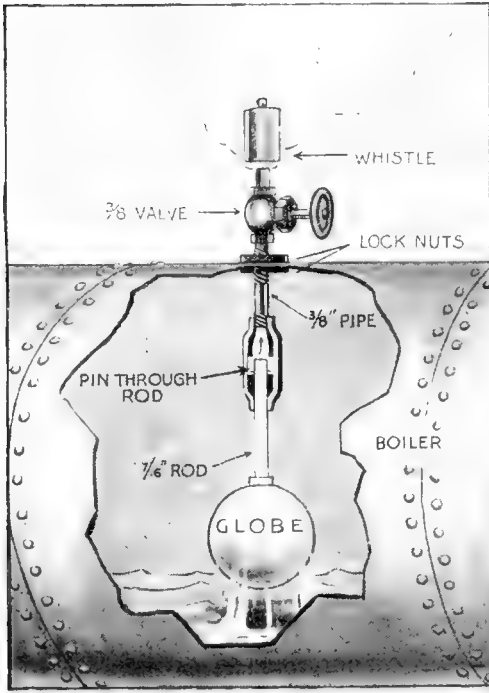

When the Water in the Boiler Falls Below a Safe Level the Whistle Will Blow

**T**HE low water alarm for steam boilers shown in the illustration has no packing boxes, the principal objection to home-made alarms.

A whistle is connected with a  $\frac{3}{8}$ -in. globe valve. From the valve a piece of  $\frac{3}{8}$ -in. iron pipe leads down. Locknuts hold the iron pipe and the boiler shell together at the top of the boiler.

To one end of a piece of rod  $\frac{7}{16}$ -in. in diameter and 4 ins. long, a washer is attached and to the other end a ball (globe) float. The  $\frac{3}{8}$ -in. pipe and the  $\frac{7}{16}$ -in. rod are held together by a  $\frac{3}{8}$ -in. check valve, which is turned upside down and the movable interior disk is then removed. A pin is passed through the rod within the valve. This pin can be easily

placed, as all upright checks unscrew to permit access to the inside.

Perhaps it would be a safer plan to omit attaching the globe valve as it might be closed accidentally or deliberately, by a careless attendant. When the water falls below a safe level the whistle will blow.—JAMES E. NOBLE.

### Locomotive Runs Three Hours on Charge from Boiler Plant

**A** FIRELESS steam locomotive is used for switching cars and tie trams at an Ohio manufacturing plant. The locomotive is of a type which was developed in Europe some years ago and is used around distillation plants, where cinders and live ashes would constitute a fire danger. It is operated by steam, the boiler being charged about seven times every twenty-four hours at the main boiler, at one hundred and fifty pounds pressure. The maintenance cost is very low. The tractive power is fully equal to that of the usual type, and although it weighs only twenty-two tons it has pulled as many as twelve loaded gondola cars at a time.

### A "Soap" Which Is Not Used for Cleansing

**F**ORTY miles removed from the familiar grease product marketed as different varieties of soap is the "grease-ball" shown in the accompanying illustration. It was formed in a boiler as a deposit resulting from the precipitation of the carbonates of lime and magnesia in the feed water.

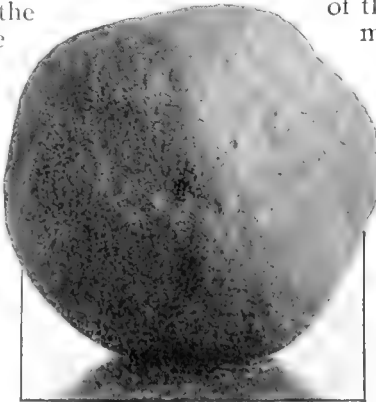

This "Grease Ball" Was a Sticky, Insoluble Feed Water Deposit Formed in a Boiler

When feed water enters a hot boiler the carbonates of lime and magnesia that the feed contains are precipitated from solution and if the circulation in the boiler is not too active the precipitated matter often floats on or near the surface for a time in light particles. When the floating carbonates unite with the organic parts of any oil that may be in the boiler the soap is formed.

Why You Could Not Get Your Man on the Wire



The Books in the Illustration Are Holding the Receiver Off the Hook, Indicating to "Central" That the Line Is Still Busy

IT is a generally conceded fact that the telephone operator at "Central" is a very necessary evil designed to teach us patience; but a study of the accompanying illustration from a photograph by Val. B. Mintun, of Kansas City, Mo., may avert a few anathemas from her unsuspecting head. The picture tells its own story most effectively. It may not be invariably the reason why you cannot get in touch with the party you desire to reach by telephone, but it very often happens that carelessness in hanging up the receiver leaves the circuit still closed, as it is when the telephone is in use, indicating to Central that the line is busy. The receiver must suspend its full weight from the hook in order to leave the line open.

A Typewriter Made Especially for the One-Armed

IN all of the belligerent countries the effort is being made to find ways and devise means by which the war-cripples may be able to support themselves when once more well. A German has invented a typewriter that can be worked with one hand and one foot. Nor is a perfect hand required, for the writing is done by moving a lever to left and right and the only other hand-movement demanded is the grasping of the paper for insertion. The typewriter has no keyboard and the characters are

on a type-cylinder. A number of the ordinary movements of a typewriter are produced by pedals worked by the foot. Thus the paper is introduced by means of the hand and foot, and the spacing of the words is controlled by the foot, the moving upwards of the paper after a line is written is caused by the foot, and the shifting of the type-cylinder for capitals, small letters, or figures is also done by foot.

Catering to the Feminine Patrons of the Bootblack

AN adjustable wooden apron or tray hinged to the seat of a shoe-shining chair is a new idea which will appeal to the feminine patrons of the bootblack. It may be swung from a depending position to a raised position in which it supports the skirts of the woman who is having her shoes shined and serves as a rest for the limbs as well. It also prevents the skirt from being soiled while the polishing is in progress.



The Wooden Tray Is Adjusted by a Slight Movement and Serves as a Rest for the Legs and a Protection to the Skirts

# Housekeeping Made Easy



This Obliging Little Dachshund Holds on His Back an Iron Scraper for Removing Mud and Dirt from Shoes. He Lifts His Task from the Menial to the Decorative



Abundant Heated Air Well Distributed Is Obtained from This Portable Air Blower Which will be Found a Great Convenience in the Home for Between-Season's Weather, and Also in Cleaning and Dyeing Establishments, Tonsorial Parlors, etc. Three Temperatures Are Assured



The Latest Convenience for the Busy Man's Telephone. It Is a Coil of Heavy Insulated Metal as a Rest for the Hand Holding the Receiver



This Useful Household Tool May Be Used as a Hammer, a Hatchet, Wire Cutter, Tack Puller, Screw-Driver, or Pipe Wrench. The Tool Is 6 1/2 Inches Long, and Not Heavy

On the Right Is Shown Two Pieces of Sponge Attached to Folding Frames with Small Pieces of Soap in the Center, Which Is the Most Recent Departure from the Soap-Box Being Also Used as a Sponge

A Pan Greaser That Consists of Lamp Wicking Fastened into a Nicked Handle Is a Sanitary Device for Greasing and Oiling Pans, as the Hands Do Not Touch the Pan At All. The Wicking May Be Washed and Renewed Whenever Desired



# Housekeeping Made Easy



The Illustration Shows an Adjustable Foot-Brace. It Consists of Two Planes, One of Which Is Braced Against the Foot of the Bed While the Other Supports the Feet

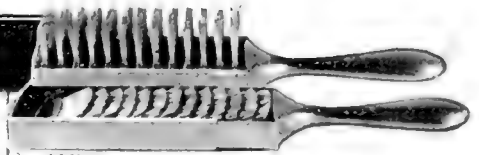

A Collapsible Hair Brush Will Be Appreciated by the Traveler. The Bristles Are Set in Metal Strips Which May Be Made to Lie Flat or Stand Upright as Required



A New Idea in Sanitary Paper Drinking Cups Provides a Straw as an Added Convenience. Each Cup Is Wrapped in a Separate Case



A Telephone Index Which Works on the Principle of a Roller Shade Has Been Put on the Market by a Boston Manufacturer. It Consists of a Coiled Spring in a Tubular Metal Case, Which is Clamped to the Pedestal of a Desk Telephone, and a Roll of Paper Ruled Off Most Conveniently



A Chicago Firm Is Placing on the Market Articles Coated with a Phosphorescent Substance. Match-Boxes, Key-Holes, Clock Faces and Electric Switches Are Treated. If Submitted to Light During the Day They Will Shine All Night

The Ice Pick Illustrated Below Is Made of Separable Parts. The Handle Is Provided with Jaws Which Clamp Tightly or Release the Three Removable Picks



## Increasing the Decorative Value of Portieres

The Latest Answer to  
"What Is a Cold?"

**A**LTHOUGH you have been told that "colds" are caught from others by the transfer of bacilli of several different varieties from one person's nose, eyes and throat to another's, a startling and revolutionary discovery just made by a U. S. Army Officer,

Dr. George B. Foster, Captain in the Medical Corps, shows that this medical teaching is almost certainly wrong.

From his elaborate experiments and unexpected results, it appears that common colds are caused by a virus, present

in the tears and nasal fluids of those affected, so small that the most powerful ultra-microscope fails to bring them to view. They will easily pass through porcelain filters, which successfully hold back the bacteria of all known infectious diseases, except such as hydrophobia, measles, foot and mouth disease, infantile paralysis, and yellow fever. These, too, are ultra-microscopic.

While the precise type of ultra-microbe present in the virus of running noses, sneezes, and tears has not yet been identified, experiments thus far prove that the porcelain-filtered product will produce colds in healthy people, and that the mucus taken from the nose of those who suffer with colds, and weakened with water 90,000 times, still retains this living virus.

Tests of this fluid were made on eleven physically sound soldiers and five drops of it were squeezed into each nostril of each of the men.

The discovery followed that colds could develop from eight hours to two days after exposure to the infection. All of the men "caught cold" within this period, though some threw off the effects of the cold virus within a few hours.



Wooden Balls Attached to Metal Hooks Which Receive the Curtain Rings Slide in a Hidden Groove with the Movement of the Curtain

**P**ROPERTY owners have learned from experience that the putting up and taking down of portiere poles is likely to result in more or less damaged woodwork.

They will be interested, therefore, in a new device which does away with these poles entirely, but without dispensing with portieres or curtains. In fact, the design increases the decorative value of the portieres.

This device looks like a moulding, but there is a large opening through the center and a slit in the bottom. Wooden balls slide back and forth inside the moulding, and metal rings attached to them extend through the slit to receive the hooks fastened to the curtains. The moulding is put up and made a permanent part of the standing finish, being painted or stained in any color or finish desired. Once in place, any set of curtains may be attached and removed at will and in a moment of time without injuring the woodwork.

The moulding is fastened to the top of the door opening, of course, and if the curtains or portieres are pinned high enough, there will be practically no space for drafts to enter.

### Shoes of Esparto Straw Which Outwear Leather

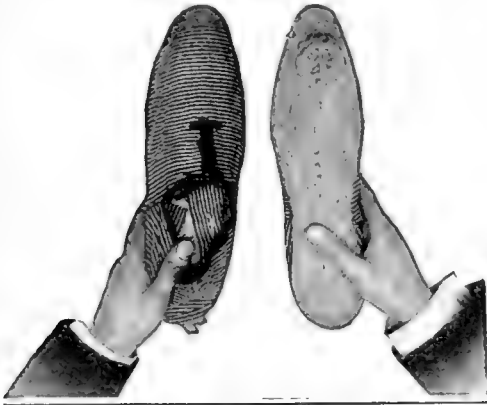

A Pair of These Esparto Fiber Shoes Have Been Known to Outwear a Dozen Pairs of the Ordinary Tanned-Hide Soles

**E**SPARTO shoes, or shoes made of the toughest and strongest of the coarse fibers, are still worn in Iberia and in some parts of Spain and Portugal. There is no shoe made which will outlast them, not excepting leather-shoes. One pair of Esparto shoes has been known to outwear about a dozen tanned hide soles. This is due to their faculty of picking up and retaining in their interstices stony or gritty particles which wear like nails.

As the shoes are worn they constantly pick up and retain these foreign particles, and as fast as these are worn out they are replaced automatically by others, providing the wearer of the shoes continues his walking. Thus a self-soling process is constantly going on.

It is not uncommon in some parts of Spain or Portugal to hear the natives boast of wearing a pair of Esparto shoes for twenty-five years or more. The soles will survive an aggregate exceeding six thousand miles of walking without wearing away appreciably.

Several years ago an attempt was made by a concern in this country to manufacture the shoes in quantities large enough to supply the demand from abroad. A plant was built, people were engaged, contracts for the delivery of the fiber were closed and the manufacturing was begun. This did not continue for long, however, for it developed that the company was obtaining an inferior grade of coarse fiber with the result that their shoes were not wearing well. Accordingly the company went into bankruptcy, with a net loss, it is said, running well into five hundred thousand dollars. At the present time genuine Esparto shoes are to be obtained only in the foreign sections of some of our large cities.

The Esparto fiber is also largely used in the European paper industry under the name of Esparto grass. It makes a paper of excellent durability, but American paper makers have not used it. It requires expert knowledge in its treatment. Esparto shoes are largely made and worn in the rural districts of France.

For a comfortable shoe for all-round wear the Esparto shoe has no peer. Those who have worn them never put them aside for leather shoes. At first the shoes are very soft, simulating velvet, but after they have been worn for a short time they become as solid and hard as leather.



### Using the Waste Heat of a Kerosene Lamp

**T**HIS illustration shows how the waste heat from an oil lamp is utilized every night to heat a kettle of water in an English engine-room.

The photograph was taken in the engine-room attached to Platte Fougère lighthouse, Guernsey, England.

The Engineer Who Utilized the Heat from the Oil Lamp Is No More Resourceful Than the Engineer Who Heats His Coffee on the Radiator

# A Locomotive That Burns Pulverized Coal

OUR modern locomotives are voracious creatures. To fire one of them—the Twentieth Century Limited, for instance—is a task gradually approaching the superhuman. The

lignite and peat, are as productive of economic results as the larger and better grades of coal. Some of the products mentioned are unsalable and have been thrown away as waste, so the great

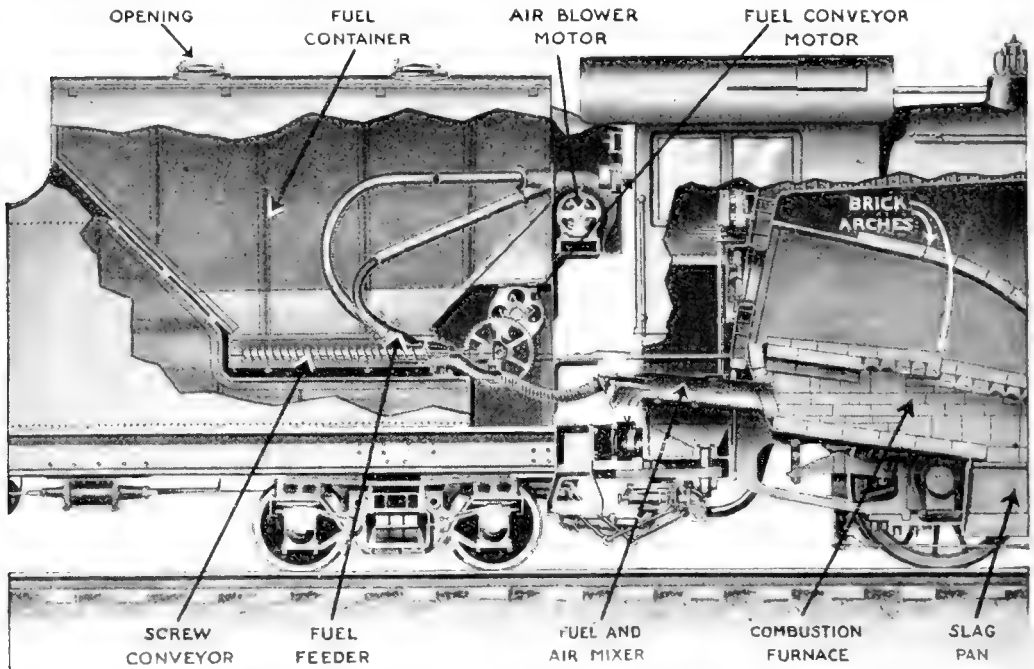

The Fuel Container, Which Is a Part of the Ordinary Locomotive Tender, Receives the Coal Dust or Pulverized Coal Through Two Openings in the Top. The Fire-Box Is Provided with Brick Arches and Air Inlets. A Slag Pan Is Used Instead of the Usual Ash Pan

only remedy, according to railroad men themselves, lies in the utilization of pulverized coal. Of only comparatively recent date, however, have appliances for burning powdered fuel or coal-dust in locomotive fire-boxes been effectively developed. The results have been entirely satisfactory, effecting a saving of from fifteen to twenty-five per cent of fuel and untold labor.

This economy is possible because any solid fuel which in a dry, pulverized state has two thirds of its content combustible will be suitable for steam-generating purposes. This means that such ordinary coal products as dust, sweepings, culm, screenings and slack, and even

saving effected is apparent. The total cost to prepare pulverized coal is something less than twenty-five cents a ton, and the preparation is not at all complicated. The coal must be dry and ground to a fineness so that it will pass through a one-hundred or two-hundred mesh screen. This is all the preparation necessary.

There are three railroad lines which have locomotives fitted with a successful apparatus to burn coal-dust. These are the New York Central, the Chicago and Northwestern and the Delaware and Hudson. The last-named system has probably the largest pulverized fuel-burning locomotive. Its tractive effort is about sixty-three thousand pounds.



In the accompanying illustration is shown the pulverized fuel-burning equipment as applied to a locomotive. The fuel container, which is a part of the ordinary locomotive tender, receives the coal-dust or pulverized coal through two openings in the top. As dryness of the fuel is a prime requisite these openings are kept tightly closed. In starting the fire the fireman turns on the steam-blower in the smoke-box, after which he

his place in the cab near the engineer.

When the powdered coal and air are mixed in the right proportions, the mixture bursts into a clear, intense flame in the fire-box, with no visible smoke at the stack. It takes less than an hour to get up two hundred pounds of steam, and when the engine is standing the fire may be put out entirely and then reignited within an hour from the heat of the brick arches in the fire-box.

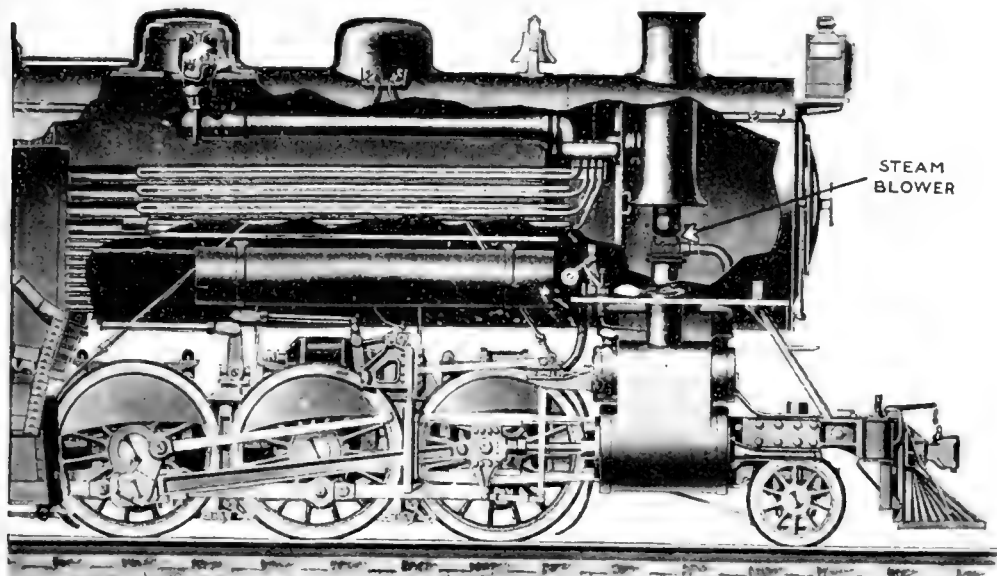

In Starting the Fire the Fireman Turns on the Steam-Blower in the Smoke-Box. The Air-Blower Motor and the Fuel-Conveyor Motor Are Then Started and Fuel and Air Enter the Combustion Furnace Which Is an Ordinary Locomotive Fire-Box with a Fire-Brick Floor

places a piece of lighted oil-waste in the furnace. Immediately following this he starts the air-blower motor and the fuel-conveyor motor. The screw-conveyor forces the fuel into the fuel feeder, where it meets the air driven by the blower. The fuel and air are then driven through a commingler, and this mixture then enters the combustion furnace, which is the ordinary locomotive fire-box fitted with a fire-brick floor in place of grate bars, where the lighted oil-waste ignites it. The fire-box is provided with brick arches and air inlets. There is a slag pan instead of the usual ash pan.

The regulating mechanism controlling air and fuel is within reach of the fireman, so he need never have occasion to leave

### The Wastage of Flying Machines In the Great War

THE English aeronautic periodicals publish fairly complete lists of casualties sustained by the flying squadrons of the Allies as well as by those of the Germans. In a single month on the western front, the British brought down sixteen German aeroplanes, the French thirty. The British losses, on the other hand, were ten, and the French twenty-eight. If machines are shot down with such ease on both sides, the wastage of aeroplanes in this war must be enormous. No wonder that thousands of men are employed in the aeroplane factories of all the warring countries to make up the losses.

# Keeping Watch on the Chimney

**T**O-DAY power-plant owners in Cincinnati are as proud of the clean condition of their stacks as they are of their clean engine and boiler-rooms and general interiors.

The city of Cincinnati has been waging a relentless warfare against the factory smoke nuisance. As the result of a campaign of education the engineer and the fireman and the boss in his swivel chair are all working together making a superb effort to reduce waste by smoke to a minimum.

The manager of one factory was so anxious to co-operate with the smoke inspection department that he installed in his office mirrors which enable him to see at any time of the day the volume and density of smoke emitting from his stack. He adjusted two mirrors in such a position that they reflect the top of the smoke stack so that they are easily seen from his desk, several feet from the window. When the mirrors divulge a smoking stack he compares the smoke density with a smoke chart tacked to the window frame beside the upper mirror. When the smoke is equal to or greater in density than "Number 3" on the chart he presses a button on

his desk which "blows" an automobile horn which is located in the engine room.

This serves to "wake up" the fireman, who immediately proceeds to give the furnace more air, and turns on steam-air jets which stop the smoke almost instantly, by burning the rich gases from the fuel bed which would otherwise go to waste. The manager continues to operate the button on his desk until the faithful mirrors report that the smoke is reduced to below the objectionable density.

The firemen in this plant are supplied with an opening in the roof of the boiler-room to enable them to see the top of the stack, and if they get careless and fail to keep the smoke within law regulations, the manager proceeds to regulate things himself by pressing the button, after determining just how much regulating is necessary by looking in his mirrors.

The plan has proved entirely feasible and the factory no doubt has an enviable reputation in Cincinnati, not only for the civic pride of the owners but also for the general efficiency of the works, as indicated by the alertness and comprehensive oversight of its manager.



Mirrors Installed in the Manager's Office Are So Adjusted as to Enable Him to See the Smoke Stacks and Gage the Density of the Smoke from a Chart Hung Nearby

# Feeling the Way

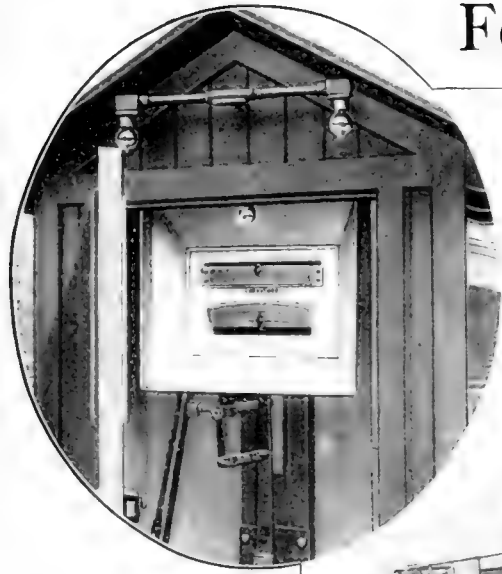

An Attachment on the Rear Truck Indicates on a Scale Inside a Cabinet in the Car the Degree of Curvature and the Elevation of One Rail Over the Other



With All Attachments Working Automatically It Is Possible to Take Clearance Measurements While the Car Is Running

**A** NEW clearance car has just been placed in service on the Pennsylvania Railroad lines east of Pittsburgh and Erie. It is being run over every division as rapidly as possible in order to secure correct measurements of the distances from the track to projecting portions of station buildings, tunnels, bridges and other objects. It is also designed to indicate automatically while moving on curves the elevation of the rails and the degree of curvature.

The car is built entirely of steel, and is equipped with air-brakes, steam fittings and electric lights. There are two floors, or elevations, both of them used for taking measurements from the templets. Clearances are computed from the center of the wheel truck, over which the main templet is erected. From an elevation of twelve feet above the top of the rails the templet tapers up toward the middle of the car at an angle of forty-five degrees.

Immediately in front of the templet is

an auxiliary templet designed to measure overhead bridges, tunnels and other objects between elevations seventeen and twenty feet above the top of the rails. This templet is capable of being raised to a height of eighteen feet by a crank and a ratchet arrangement on the floor of the car. Enclosed in steel cylindrical boxes with translucent glass fronts facing the templets is a series of electric lights which extend from the floor of the car on each side to a height of fifteen feet. Light from these makes it possible to take measurements both day and night.

Attached to the feelers and the side of the templet are graduated scales which indicate automatically the distance from the rim of the templet to a side or overhead object. In addition, a small board equipped with a set of feelers spaced one inch apart has been provided to measure cornices of roofs, of shelter sheds, or other irregular objects.

# The Sensitive Brazil Nut

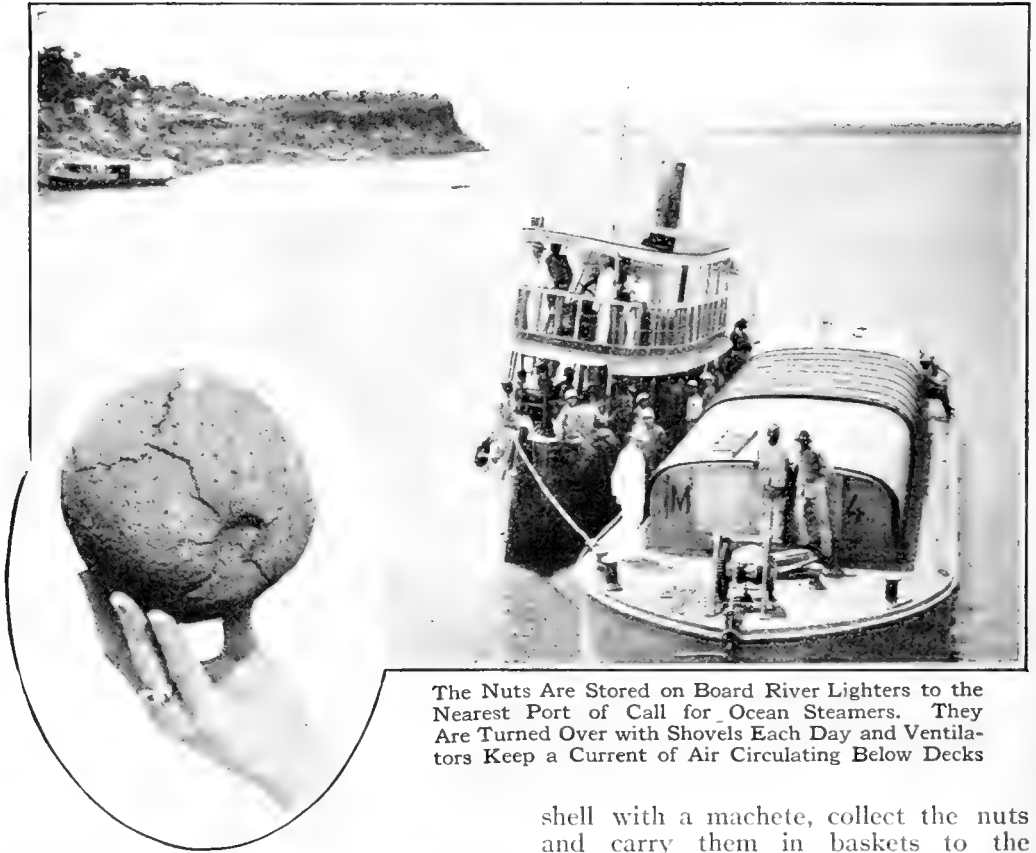

The Nuts Are Stored on Board River Lighters to the Nearest Port of Call for Ocean Steamers. They Are Turned Over with Shovels Each Day and Ventilators Keep a Current of Air Circulating Below Decks

**A** POD with a diameter of from five to six inches, in a thick, hard woody outer covering, contains the so-called Brazil nut of commerce, from twenty to twenty-four of these seeds being closely packed in one shell. On board the vessels the greatest care is taken of the nuts. They are turned over daily and kept supplied with a constant current of fresh air. Twenty-four hours of stormy weather in which the ventilators have to be closed is sufficient to ruin an entire cargo. Every precaution is taken to keep the atmosphere "comfortable," for the sensitive nut feels the slightest change of temperature.

As they begin to ripen the pods fall and are gathered by the natives, who, cutting the outer

shell with a machete, collect the nuts and carry them in baskets to the rivers on which they are transported by canoe, launch, or river steamers, to the nearest port of call for ocean steamers on the Amazon River.

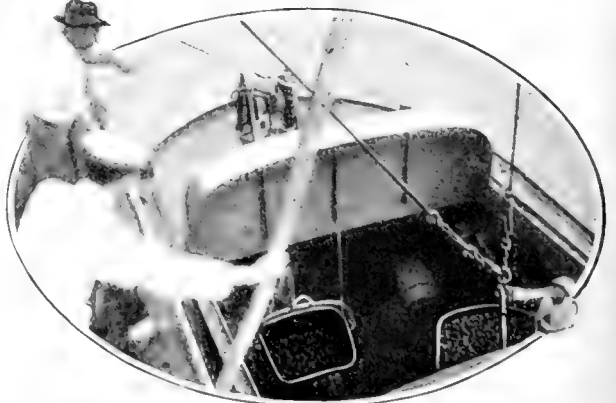

Steel Tubs Are Used in Transferring the Nuts to the Ocean-Going Steamers from the Lighters as an Extra Precaution Against Dampness

**Tethering the Largest of the Super-Dreadnoughts**

**T**HE illustration represents the largest anchor ever made. It weighs twenty thousand pounds.

It is made of cast steel; that is, a liquid steel poured in a mold of sand, made from a pattern of wood similar in shape to the anchor itself. The anchor which had the distinction of being the largest in the world previous to the manufacture of the one illustrated here, was one weighing eighteen thousand five hundred pounds.

The principal use to which this size anchor is put is for anchoring the largest super-dreadnoughts which the United States Navy is now building. The great battleship or super-dreadnought "Pennsylvania," recently put into commission, is equipped with such anchors. Smaller anchors of the same type are used widely on both Government, foreign and merchant vessels, the smallest weighing two hundred pounds. The smallest battleships and cruisers have anchors weighing usually from eight thousand five hundred pounds to sixteen thousand five hundred pounds each.

The design of the anchor is simple. It is constructed on the ball and socket principle with no pins to break or bend or drop out.

The fluke, or main portion, is in one solid piece and the shank has an end like a ball working in a socket.

Many anchors are hinged on a pin which rusts out and fails to hold.

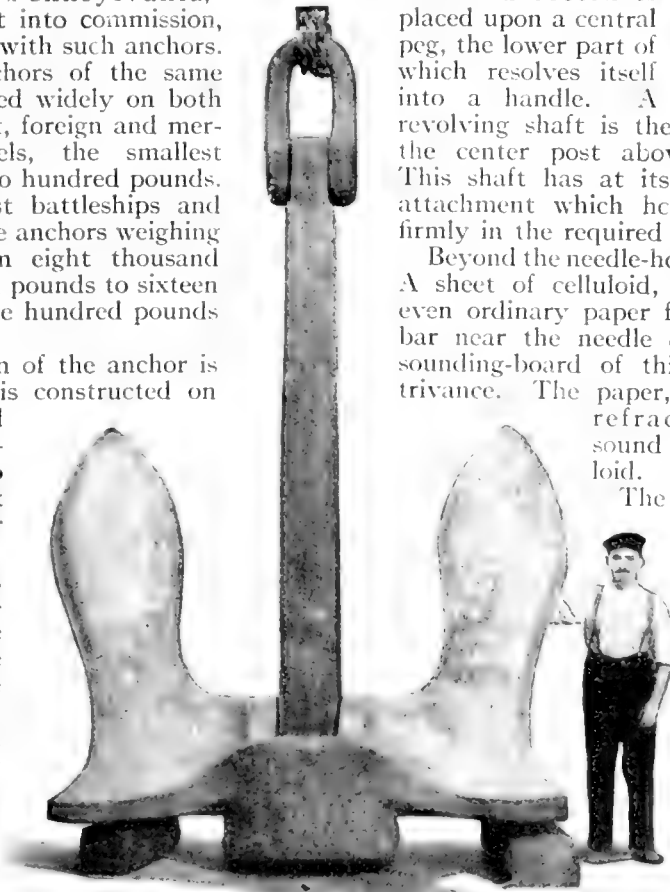

The Anchor Is Constructed on the Principle of a Ball and Socket, with the Fluke or Main Portion in One Piece

**A Hand-Made Hand-Played Phonograph**

**A** KANSAS CITY man has invented a "phonograph" which is operated by hand and which may be built at a



A Phonograph Which Requires No Expensive Cabinet. It Will Play Any of the Standard Records

cost of ten or fifteen cents. On this odd instrument, any

standard record is placed upon a central peg, the lower part of which resolves itself into a handle. A

revolving shaft is then placed upon the center post above the record. This shaft has at its outer end an attachment which holds the needle firmly in the required position.

Beyond the needle-holder is a weight. A sheet of celluloid, parchment, or even ordinary paper fastened to the bar near the needle constitutes the sounding-board of this unique contrivance. The paper, however, will refract a thinner sound than will celluloid.

The "phonograph" is operated by a twist of the wrist. The weight at the outer end of the revolving shaft insures its circular motion and the needle, following the grooves in the record, spirals its way toward the center of the record.

# Your Meerschaum Pipe



By Felix J. Koch

Pipes in Various Stages of Construction. Cutting the Meerschaum Is the First Step. Then a Hole Is Drilled in the Embryo Pipe-Head Into Which the Future Bowl of the Pipe—a Plug Worked Up on a Nearby Lathe—Must Fit. When the Pipe Is Mounted On This Part the Shaping Process Is Commenced

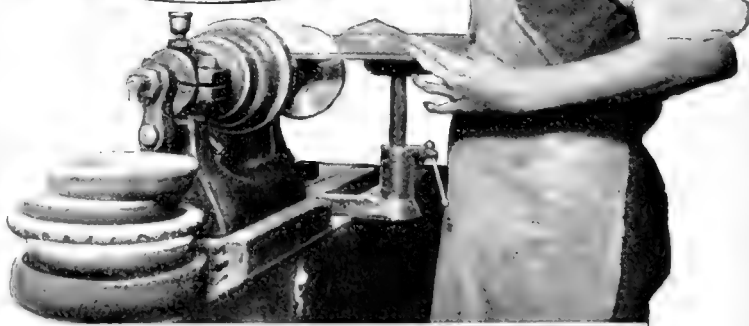

**M**EERSCHAUM pipe-making is one of the most interesting processes of the American mid-west. In normal times, the meerschaum comes from abroad. Just now, that export has stopped, and the pipe-makers of Cincinnati get it from others at home—wherever it may be bought. It is shipped in white blocks, resembling ivory. But the substance is considerably whiter than the usual elephant-tusk and is very much lighter. In fact, the lightness of

a given block of meerschaum is astonishing. Handled for American manufacturers largely through New York commission houses, most of the best meerschaum is brought from Turkey in Europe. It arrives in little chests, or *kasten*, within which each separate piece of the substance is found securely wrapped in cotton. Such meerschaum is paid for by the number of pieces. Curiously enough, the dealers prefer small pieces to large, since it takes an

expert cutter to know how to cut such with minimum amount of waste. Skilled meerschaum-cutters out of a job are not easy to find.

Cutting the meerschaum—the first step in pipe manufacture—is done with an ordinary saw. A good workman can cut the forms for perhaps two dozen pipes from the raw material in a single working-day. As cut, these rough forms are thrown into cold water to soak. In the water they are left until the supply desired is cut up and the man ready to go on with the pipes.

Rudely resembling the ultimate pipe, each form is taken in hand and a hole drilled into the pipe-head. Into this hole—the future “bowl” of the pipe—a plug, on a nearby lathe, must fit. With the embryo pipe mounted on this, “shaping” is begun.

Meerschaum pipes are shaped from the stem end on. Different men require varied types or forms of pipes; though the so-called “Bull Dog” shape and the blunter “Hungarian” pipe, and again, the egg-shaped bowl predominate. The

base of the pipe is cut off by hand because it does not fit to the lathe.

That we of to-day should still find use for the rush of the wayside-brook is indeed interesting. For the next step in the process old-fashioned rushes are used—cut into slits and employed for polishing the pipes. Usually the rushes are moistened for such use. They impart a polish which, it appears, cannot be otherwise obtained.

Neatly shaped and polished, your meerschaum pipe must be subjected to still another process. The pipe is boiled in common bee's wax, because no piece of meerschaum in the raw state will “color” as smokers require.

After this boiling the pipes are permitted to cool. Then they are given another polishing—this time with cotton flannel sheets and prepared chalk. Even that does not suffice. There must still go to that pipe a final hand-polishing, done with alcohol.

From the time of starting a pipe until its completion, a half-day's steady labor of the most skilful workmen is required.



A Good Workman Can Cut the Forms of Perhaps Two Dozen Pipes from the Raw Material in a Single Working Day. These Forms Only Rudely Resemble the Ultimate Pipe shape



Pipes when finished are classed, according to the meerschaum of which they are made, into first and second grades. And prices for the simple pipe will run from \$3.50 to \$10, or even \$15 at the factory.

Carved pipes, of course, will range to almost any price; twenty-five dollars is perhaps the least for which one can hope to get a fine pipe. Naturally, the price of the meerschaum has much to do with this.

Meerschaum is not, as so many suppose, a spoil of the sea; but is quarried or dug in Anatolia. The fair grades of the stone are found one hundred feet below ground. The deeper you dig the better is the product. The splendidly carved pipes, of which every pipe lover will have one or two, are almost always a deep mine product.

Good meerschaumpipes, if of the softer stone, should color in a year. Others may take two or three years. There is no better taste

with the "colored" pipe; though enthusiastic smokers often delude themselves with the belief that there is.

### The Floating Vegetable Gardens of Mexico

THE Lake of Xochimilco, near the city of Mexico, is nearly covered with floating gardens called chinampas, on which are cultivated vegetables and flowers for the city markets. They are formed of floating masses of water plants covered with soil and secured by poplar stakes. The latter take root and surround the islands with living hedges, which are useful as well as ornamental.

### Fishing in Guiana with the Bow and Arrow

INSTEAD of using nets or the conventional hook and line, the natives of Guiana shoot the fish with bow and arrows. The arrow used is designed especially for this purpose and is about five feet in length, with no feathers. The head, which is barbed, is made from sheet iron and is provided with a socket which is slipped over the end of the shaft by a light, strong line about ten feet long.

When the fish is struck and the barbed point is buried in its flesh the cane shaft

floats free and resting upon the surface of the water serves as a buoy to mark the catch, which is hauled in by means of the line attached to the head.

Fish weighing from ten to one hundred pounds are caught in this manner. When there are no fish visible or when they are too far beneath the surface to shoot with certainty the natives resort

to "calling" the fish. This is accomplished by uttering a low whistling sound and waving the finger tips in a peculiar manner. Surprising as it may seem, the fish often approach the hunter within bow shot when thus called.

But one does not need to go to far-away Guiana to see fish killed by the bow and arrow. Our own Native American Indians are past masters of the trick, and a sojourn with them in one of the western reservations will convince the visitor that shooting fish is one of the Indian's favorite pastimes. An arrow much shorter than that used by the natives of Guiana is used, and no line is attached to the head of the arrow.



With His Bow and Five-Foot Arrows the Guiana Native Can Shoot and Kill Fish Weighing from Ten to One Hundred Pounds After "Calling" Them Up

# The Story of Petroleum

By C. W. Stratford

The author is an engineer connected with a great oil-refining company. His article, while it describes the general principles of oil-refining, is intended to explain how lubricating-oil in particular is obtained.—EDITOR.

**T**HERE is a vast difference between petroleum as it flows from the earth and its derivatives. An oil refinery is a region of giant stills, filters, storage tanks, steam and power plants, coal bunkers and laboratories. Its working population is equal to that of many

towns. Immense workshops are required to manufacture the hundreds of thousands of barrels, boxes and tins in which its many products are shipped.

Crude oils are not simple chemical compounds but consist of a physical mixture of different compounds of the element carbon and element hydrogen.

Other elements such as sulphur, oxygen, nitrogen and metallic salts, etc., are present as impurities. Each one of these many compounds has its own definite physical properties, such as fixed boiling point, gravity

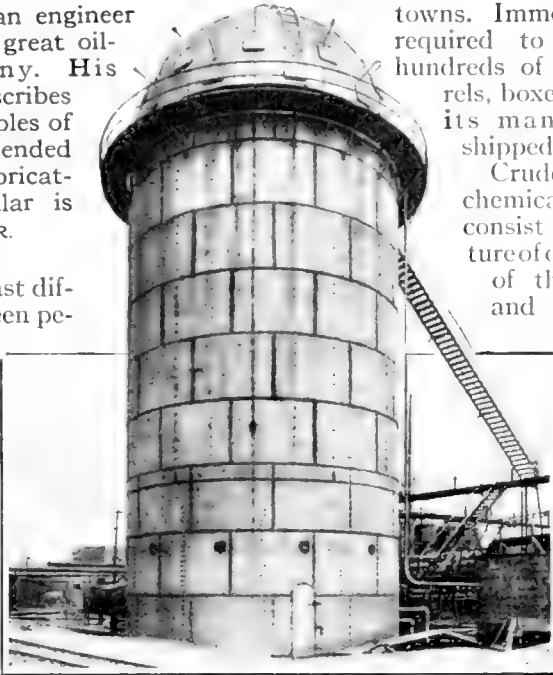

The Agitator Is a Lead-Lined Steel Tower for Bleaching Oil and for Removing Impurities

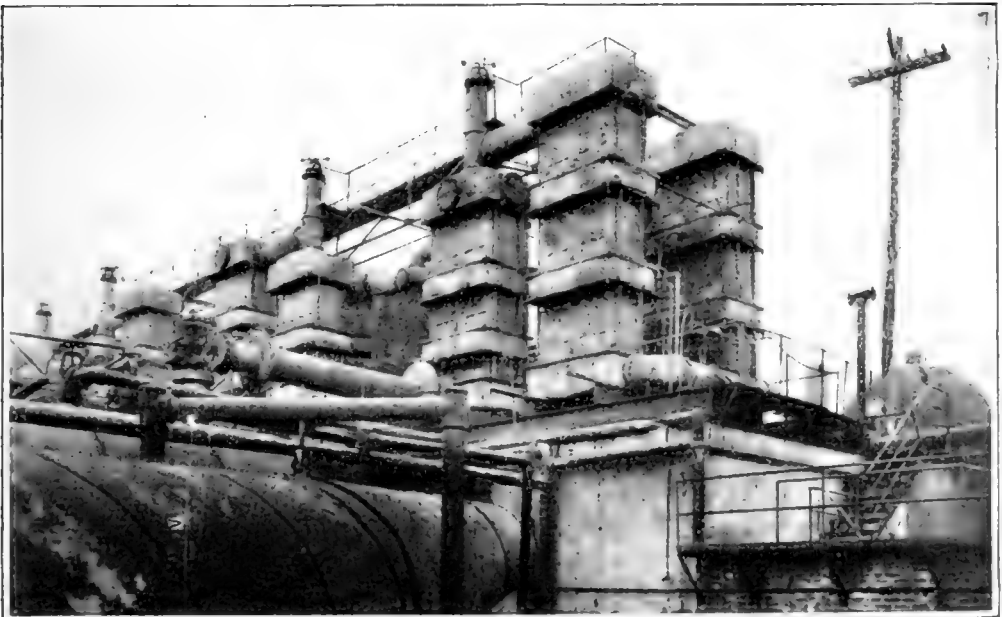

Battery of Aerial Condenser for Automatically Condensing Different Distillates, Which Are Then Conducted Through the Water-Cooled Pipes to Their Respective "Running" Tanks

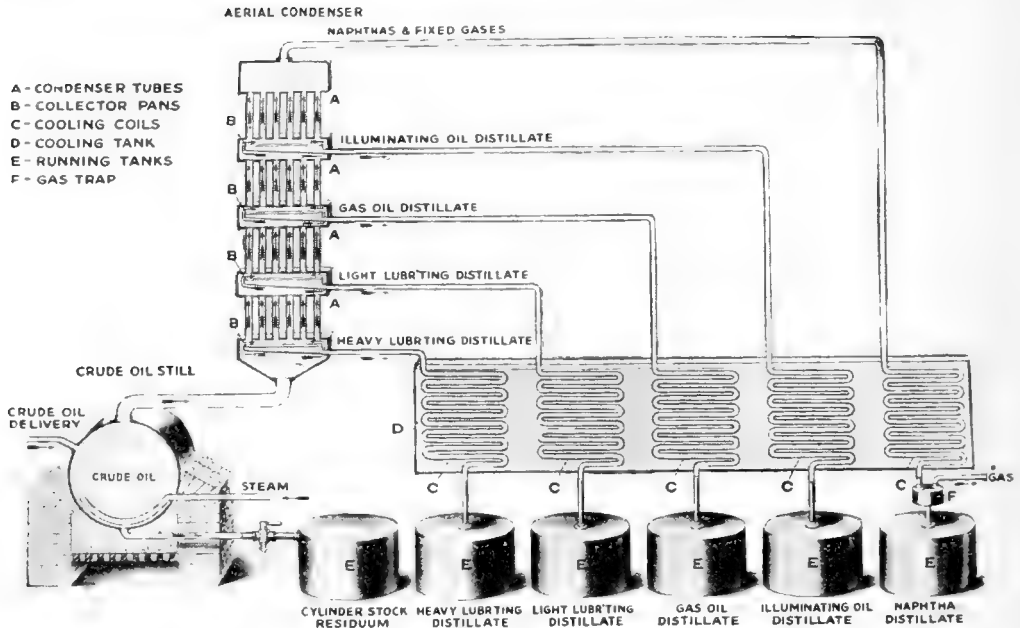

Fig. 1. First Separation of Crude Petroleum Into Groups by Distillation

and other specially distinguishing characteristics.

As cream, butter, cheese, casein, and other products are derived from milk, so are hundreds of different hydro-carbon compounds lying between the extreme limits of gasoline and cylinder stocks or coke, separated from crude oil by fractional distillation. These products are divided into many different grades, according to their physical and chemical characteristics, and to the purpose for which they are used and shipped to all parts of the world, wherever an internal combustion engine is run, a lamp burned, or a wheel turned.

Crude oils may be divided into three main families: those of paraffin, asphaltic and cyclo-naphthene base. There is no sharp line of separation between these groups, since most crude oils found in all fields may contain mixtures in variable percentages of hydro-carbons, belonging to two or more families.

When the crude petroleum arrives through the pipe line and is deposited into storage tanks of large capacity, a certain settling takes place. The semi-solids which settle out consist of amorphous paraffin wax, mud or other earthy foreign matter and impurities.

#### *First Stage—Separation into Groups by Distillation*

From the storage tanks the crude oil is pumped into a large cylindrical boiler, called a "crude still."

Distillation as applied to hydro-carbon oil, is the separation of the more volatile portions from the less volatile portions by vaporization, and later condensing them by passing the hot vapors through a cooled tube. Light hydro-carbons like gasoline, vaporize very readily, whereas heavy oils form practically no vapors at atmospheric pressure and temperature; therefore, it is necessary to heat and boil crude petroleum in a closed vessel, in order to accomplish complete vaporization and separation of the different hydro-carbons. Since crude oil is a complex mixture of hydro-carbons, each of which has a different boiling point, a different temperature is required for the vaporization of each compound. Dissolved gas and the lightest hydro-carbons pass over first, and as the temperature is increased, heavier and heavier hydro-carbons are vaporized.

Reverting to Figure 1: The vapors formed are led through a pipe from the still and discharged into the base of an aerial tower condenser. From there they

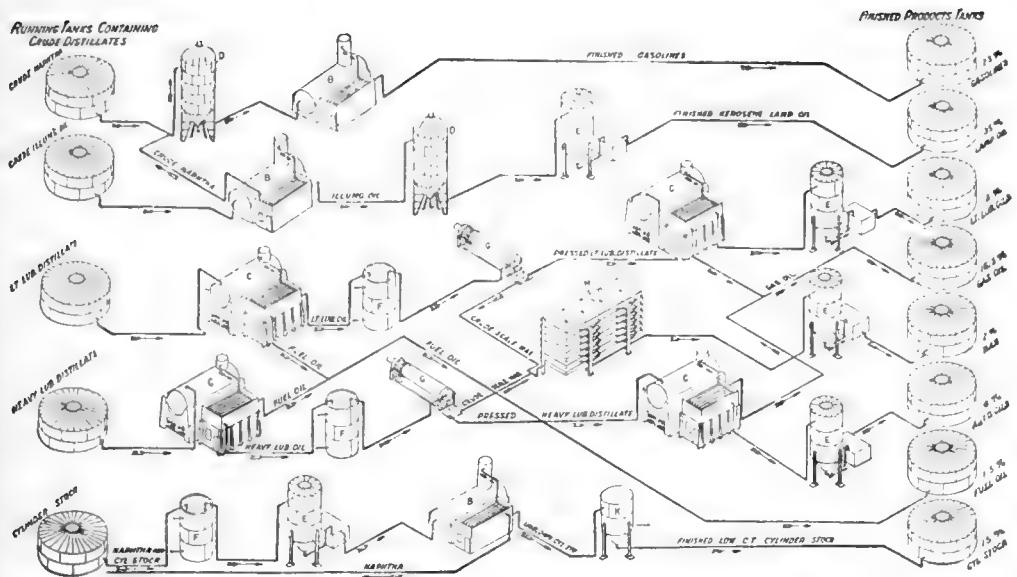

Fig. 2. How Pennsylvania Crude Oil Is Refined

- B—Steam Still                    D—Agitator                    F—Chilling Tank                    H—Wax Sweater  
 C—Steam and Fire Still        E—Fuller's Earth Filter        G—Wax Filter Press                K—Air Drying Tank

pass up through alternate boxes and air-cooled tubes, where products of different boiling points are simultaneously condensed and thus automatically separated into groups. The lightest products pass completely through the tower and flow in vapor form to a water cooled condensing coil, where all light hydro-carbons condensable without the application of pressure, are liquefied and separated from the remaining vapors, which are further treated at a compressor plant, for the separation of very light hydro-carbons from the "fixed" gases. Of the remaining vapors, the heaviest condense upon striking the first air-cooled tubes, and the lightest upon striking the last tubes. Intermediate products, lying between the light and heavy ends, condense in the intermediate tubes, depending upon their respective boiling point. The vapors liquefying in different sections of the aerial condenser fall back into corresponding collector pans, whence each is led by way of a separate water-cooled coil to the storage tanks, called "running tanks." The liquids recovered in the collector pans are still at a temperature above their fire points, and it is necessary to cool them down to prevent spontaneous ignition,

when they come into contact with air in the running tanks.

Distillation continues until a residue (crude cylinder stock), of about 15 per cent. remains, when the fires are drawn and the remaining oil is pumped from the still through a cooler into a running tank.

The quantity and quality of products obtained from this first separation depend upon the method of distillation employed and from the base or "family" to which the crude petroleum belongs. This description, however, only concerns Pennsylvania crude oil of paraffin base. High quality oils are obtained when the separation is made by distilling under vacuum or by the use of fire in combination with steam injection. Due to the mixture of oil and water vapors in fire and steam distillation, oil vapors pass over at lower temperatures than were fire used alone. This prevents the occurrence of any serious "cracking" of the heavier products.

*Second Stage—Separation and Finishing of First Groups*

The prime object of subjecting the group-distillates from the running tanks to different processes is to further

separate each group into the final market form of the many products contained.

The secondary purpose of refining is to remove the impurities, color-bearing, and unstable or unsaturated compounds and free carbon. It may be well to point out at this time that in the first group distillation there is no sharp line of demarcation between gasoline and illuminating oil or between any other similar fractions. Heavy constituents are mechanically carried over with the light portions and more volatile products are mixed with the heavy parts. In order to completely separate these, further distillation is necessary.

The crude naphtha distillate is pumped from the running tank to an agitator where it is treated with sulphuric acid, washed with water to remove the free acid and neutralized with caustic soda, again washed and separated from the water. The treated naphtha is next sent to a steam still where it is divided by distillation into various market grades of gasoline and pumped from there to the finished naphtha storage tanks. (Fig. 2.)

The illuminating oil distillate is pumped to a steam still where the crude naphtha contained is separated by distillation and sent to the crude naphtha still. The illuminating oil remaining is sent to an agitator where it is acid treated, washed, neutralized, rewashed and filtered through Fuller's earth (Fig. 3) and pumped to the finished kerosene lamp oil storage tanks.

The crude light lubricating distillate passes from the running tank to a steam and fire still, for the purpose of changing (by heat) the character of the paraffin wax from the amorphous condition to wax that may be crystallized and for separating the fuel oil content. The lubricating distillate then goes to a chilling tank where its temperature is

lowered to such a degree as to cause crystallization of the wax. In this chilled condition it is then pumped to a wax filter press, under high pressure, where it is separated into crude scale wax and pressed lubricating distillate. The pressed distillate then goes to a steam and fire still, where the gas oil is separated from it. The remaining distillate is then divided into lubricating oils of different viscosity, varying from very light to medium light, by fractional distillation.

The oils of different viscosities resulting from this fractional distillation are next sent to a Fuller's earth filter for the removal of color-bearing compounds and free carbon. From the filter, these oils are pumped to the finished lubricating oil storage tanks.

The crude scale wax is sent from the wax filter press to a sweater, where it is separated into scale wax and oil. The scale wax then goes to a Fuller's earth filter, through which it passes to the finished paraffin wax tanks.

The crude heavy lubricating distillate follows the same course in processing as that indicated for the light distillate. Fuel oil and paraffin wax are separated in the same manner. The fractional distillation of the remain-

ing oil results in lubricating oils of heavier body than those recovered by the processing of the light lubricating distillate.

Crude cylinder stock is greatly thinned with naphtha, and then sent to a chilling tank where the paraffin wax, from which vaseline is made, settles out. The oil-naphtha portion is pumped to a Fuller's earth filter for the removal of color-bearing compounds and free carbon. From the filter it passes on to a steam still where it is separated into naphtha and low cold test cylinder stock. From the still the oil is sent to a tank where it is blown with air to remove traces of moisture and then to the finished storage tanks.

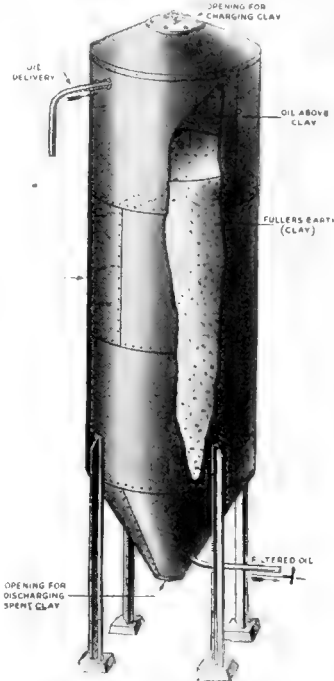
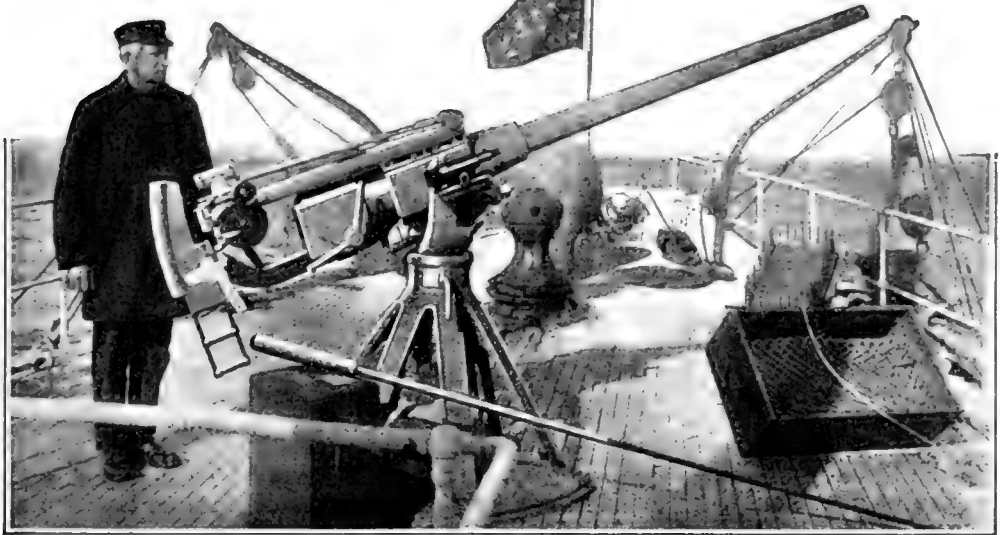

Fig. 3. Fuller's Earth Filter

# Rapid-Fire Guns Save Lives



In Line Shooting with the Rapid-Fire Guns a Projectile About Six Feet Long Is Used. The End Which Is Inserted in the Gun Is a Cylindrical Piece of Steel Slightly Smaller Than the Bore of the Gun. The Line Is a Hemp Rope About the Size of a Wash Line

**T**HE three and six-pounders with which all the sea-going cutters of the service are armed now are used to shoot lines to vessels in distress. For years they had served as nothing more than ornaments on the decks of the cutters; for it never was necessary to use them in the enforcement of customs and navigation laws. They were carried mainly for their moral effect.

These guns have been found far more effective in line shooting than the line guns formerly carried—small brass cannons of the type seen at life-saving stations along the coasts. Although the cannons were in use for many years, they were never entirely satisfactory. It was almost impossible to aim

them with any degree of accuracy, and accordingly line shooting with them was a "hit or miss" matter in the majority of cases.

In line shooting with the modern rapid-fire guns, a projectile about six feet in length is used. The end, which is inserted in the gun, is a cylindrical piece of soft steel slightly smaller than the bore of the gun and about a foot in length. It is tapered down to a rod

about a half inch in diameter and five feet or more in length. There is a forged eye at the end of the rod to which the end of the line is tied.

The line is a loosely-twisted hemp rope about the size of a wash line. About one thousand five hundred feet of



The Old 56-Caliber Sharpe's Carbine Is Also Used Now as a Line Shooter. A Blank Cartridge Is Used to Fire the Projectile to the Vessel in Distress

it is woven back and forth around wooden pins set in a receptacle the size of a trunk, known as a "faking box." After this operation the box is turned upside down and the frame work holding the pins is withdrawn, leaving the line ready to be "fed out," without becoming tangled. Prior to the insertion of the projectile in the gun, the first twenty or thirty feet of the line are dampened, so as to give it more elasticity and lessen the danger of its parting. A cartridge containing about ten ounces of black powder is inserted in the breech of the gun which is then aimed and fired.

After having traveled about two hundred feet from the gun, the heavier end of the projectile causes it to turn in mid-air and assume the position of a comet with a long tail streaming behind it. Successful shots have been made with the three and six-pounders up to a distance of one thousand two hundred feet, and it is believed by Coast Guard officers that further experiments with the guns will result in shots of two thousand feet and more.

The use of the rapid-fire guns for line shooting is something entirely new. For some time the Coast Guard has been utilizing shoulder guns for line shooting when a cutter can get to within 450 feet of a vessel in distress. The shoulder gun is another example of a gun designed to destroy but now used to save. The gun used for this purpose is the old 56-caliber Sharpe's carbine, the first breech-loading arm extensively used by military forces in this country. Although of obsolete type the weapon is well suited for line shooting and costs much less than any other type of gun that could be provided for the purpose. The barrel is cut down to about fifteen inches in length and the breech block is constructed so as to receive a center-fire cartridge.

The projectile, shaped like that fired in the big guns, is only about a foot long, and the largest

end is about a half inch in diameter. The line is also of a smaller size, and, instead of being held in a "faking box," is wound into a ball, which a sailor who stands beside the gunner holds in his hands. The line is wound in such a way as to allow it to "feed out" from the center of the ball. A regulation 56-caliber blank cartridge is used to fire the projectile.

#### Carpenter's Level, Compass, Grade-Finder and Periscope Combined

A LEVEL and grade finder has been placed on the market which will not only give the exact distance out of the true level but will enable the operator to ascertain at one glance the true slant on any line or grade, either in degrees, inches or percentages or all at the same time.

It can be mounted on a tripod and used in all forms of grading, laying out roads, landscape gardening, placing of pipes for drainage, ascertaining fall of water, grade of hills for automobilists, cutting of rafters and laying off and leveling buildings.

A spirit level glass placed in the middle of the instrument can be seen from all sides if it is placed at an elevation. By noticing the pointer on the dial it will give three guides for leveling. One of the most novel features of the instrument is an adaptation of the periscope principle in determining grades and their percentages.

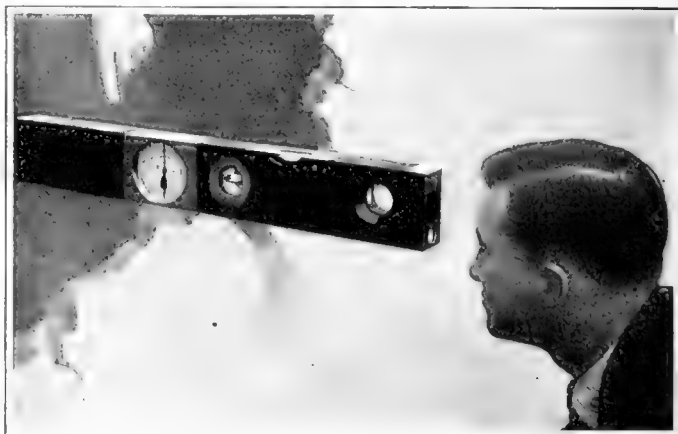

If Placed at Sufficient Elevation, a Spirit Level Glass in the Middle of the Instrument Can Be Seen from All Sides. The Pointing Hand Can Be Plainly Seen Through the Lens



# Railroading with Motor-Trucks

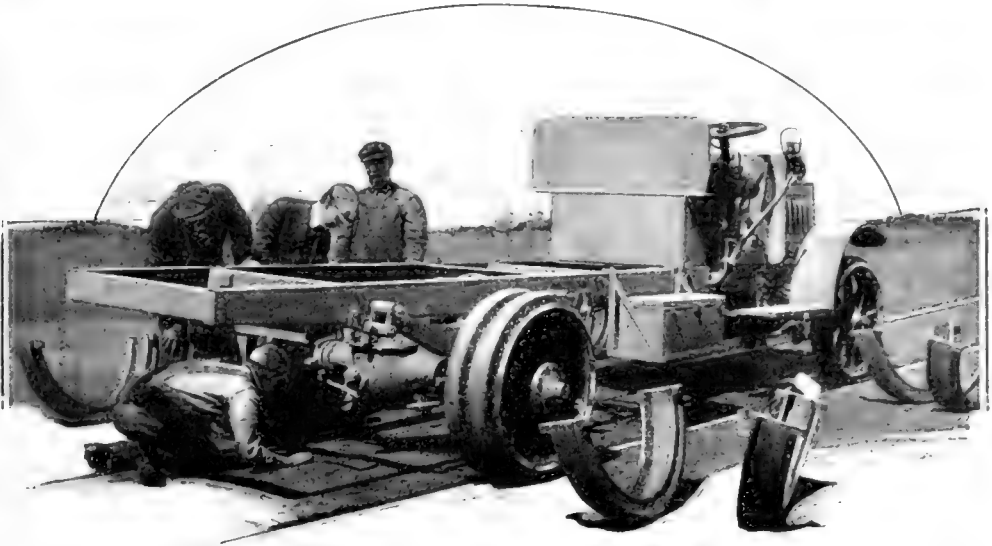

On the Three-Ton Trucks the Front and Rear Tires Track Exactly and Are the Same Size. The Steel Rings Grip the Rubber Tires with Great Force in a Tight Fit. It Requires Only About Fifteen Minutes Time for Two Men at a Wheel to Fit On or to Remove the Flanges

**T**HE very latest scheme which has been employed for bringing the automobile up to maximum efficiency and usefulness is, as so many other inventions and improvements have been, a result of war times. The Army wanted motor-trucks that could run on railroad tracks, making them of service over the route to Mexico, in places where the railroad tracks make otherwise impassable sandy stretches usable. So A. L. Riker, an engineer widely known as a designer and builder of automobiles and motor-trucks, devised and developed a scheme for using flanged wheels on three-ton trucks, permitting their use on rails of standard width.

The flanges are made of steel, which is cast in one piece and machined; after which it is sawed apart at the bolt-lugs. The inside is finished to the same contour as the rubber tire and is made to fit so tightly that it

grips the rubber tire with great force.

A set of the flanges can be put on in fifteen minutes, two men being employed on each wheel. The truck is jacked up and the flanges are pounded on with a maul. Then the bolts are pulled up very tight. Removing the flange requires no greater length of time, but in an emergency the trucks can be driven on the roads without removing the steel rings.

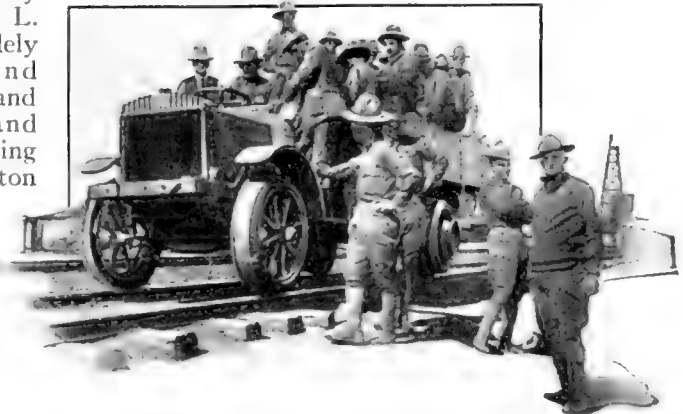

The Trucks Equipped with the Flanged Wheels Can Be Run Over the Ordinary Railroad Tracks of Standard Width. The One Above Was Loaded with Munitions and Carried Twenty Soldiers Ninety-Three Miles at Nineteen Miles an Hour

# The Biggest Coal Ship in the World

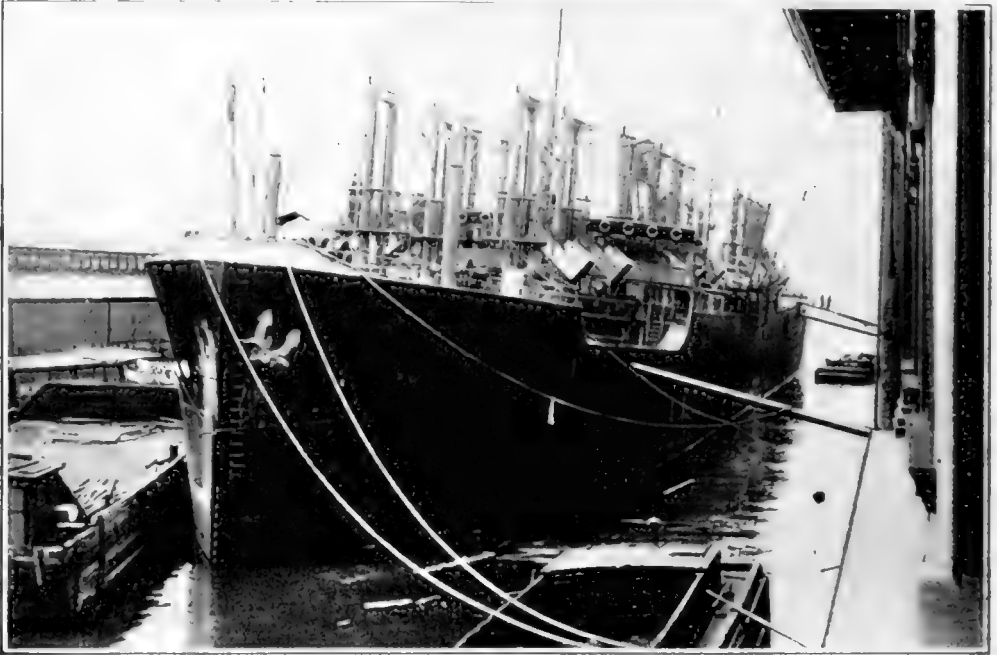

There Is Nothing Romantic About the "Milazzo." She Is Built for the Brutally Practical Purpose of Carrying Coal. By Means of Twenty Cranes on Her Decks 14,000 Tons of Coal Can Be Unloaded in Forty-eight Hours. Shovels Are Unnecessary on the "Milazzo"

**L**OOK at the "Milazzo" and watch her unload 14,000 long tons of coal and 4,500 tons of oil, and you say at once: "An American designed her—she is practical." In truth, there is nothing quite like her in the whole world, as ships go. On the other hand, she was designed not by an American, but by an Italian, Captain Emilio Menada, who has earned a reputation for himself as an inventor of transporting machinery.

The "Milazzo" was built to handle bulk cargoes, such as grain and coal built, moreover, to handle them with the least possible human effort. Accordingly, she is simply an engine-driven hull and a mass of elevators and chutes.

Eight water-tight bulkheads, extending to the main deck, divide the hull of the "Milazzo" into nine compartments. The central compartment contains the engines and boiler fuel. Salt water ballast is carried in the extreme forward and extreme after compartments. That

leaves six compartments for the coal.

If you will study the sectional view of the "Milazzo," which appears on the opposite page, you will see that the compartments are merely coal-pockets, similar to those built on wharves. Beneath the coal-pockets, little cars run on rails. When doors, cut in the slanting planes forming the bottoms of the coal pockets, are opened, the coal runs down into these cars by its own weight. When a car is full, it is lifted bodily through vertical elevating shafts up to the main deck to an unloading platform, adjustable in height. Then it is tilted, and the coal runs into chutes. Shovels and grab-buckets are unknown on the "Milazzo."

The 4,500 tons of oil are carried in side tanks forming a double bottom.

With her gross tonnage of 11,477, the "Milazzo" is the largest steamer thus far built for cargo carrying. She is four hundred and ninety-two feet long and draws twenty-six feet of water. Her displacement is 20,040 tons.

# A Vessel Built to Carry Coal

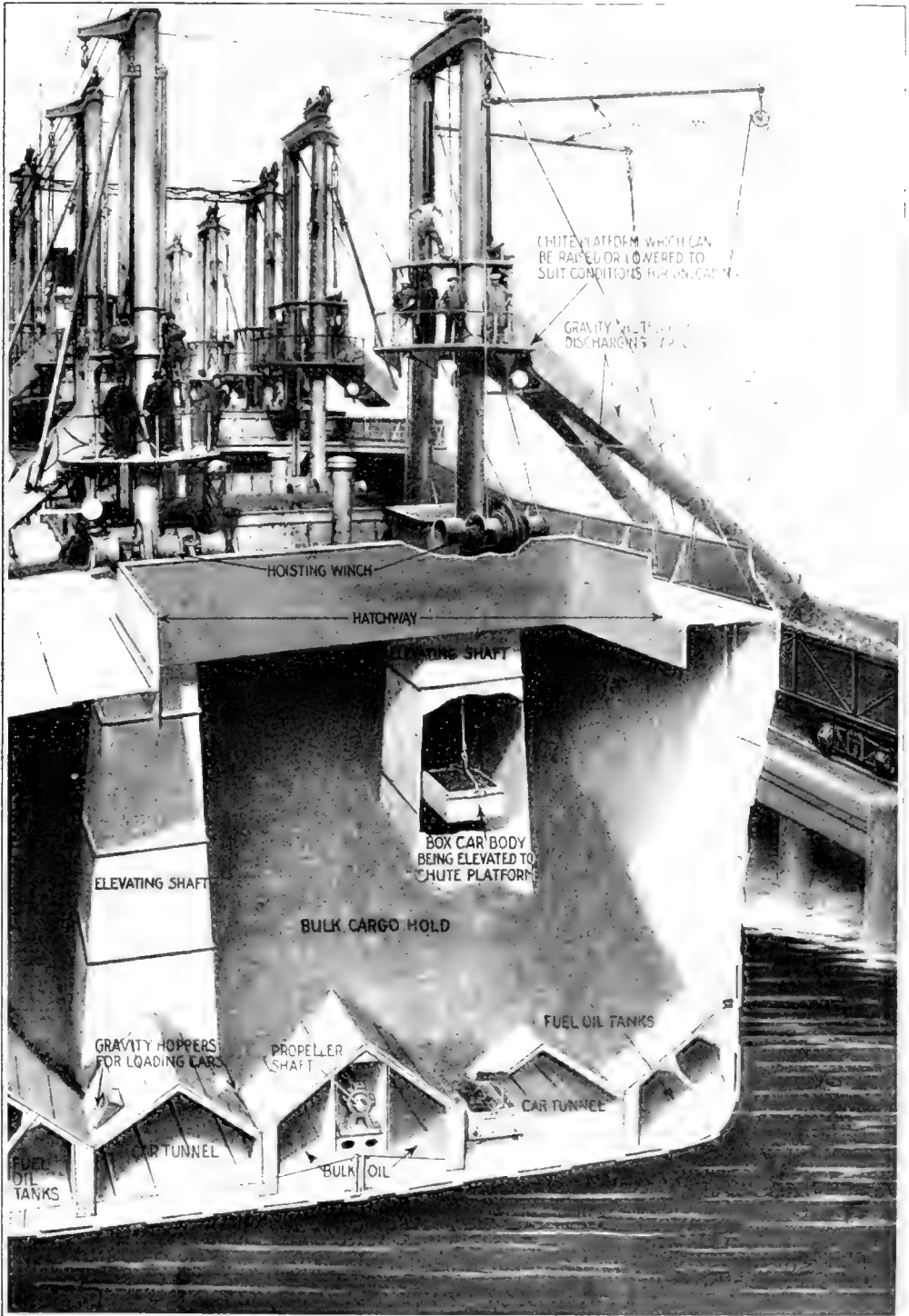

Far Down in the "Milazzo's" Hold Are Tracks for Cars. Above the Tracks Are Coal Pockets. Open the Doors in the Pockets and Coal Drops Into a Car. The Car Is Raised Bodily Through Shafts to a Loading Platform, and the Coal Shot Into Cars or Lighters

# Mechanical Joys of Coney Island

By Stephen W. Symons

**H**ALF the people who go to Coney Island and similar pleasure resorts, have but one aim in view—to get their fill of thrill. That being the case, an art which may be called “thrill engineering” has been developed. Strange as it may seem, thrills, to be of any commercial value, must not be really dangerous, but must have a goodly admixture of that popular element “Safety First.”

Anybody could design and operate, for a single performance, a real smash-up, but it takes a knowledge of engineering to produce a near smash-up that is as safe as a cruise in your arm-chair.

Three things are necessary to make a commercially successful “Thriller.” It should have a genuine thrill or some really interesting feature in it; it should be absolutely safe; and it should be

sufficiently economical in operation to make it possible to reduce the fee for admission to a figure well within the means of the average purse. Some of the most successful devices are based on the natural aptitude of many of our supposedly sophisticated city folk to look and act foolish. Others, designed generally for the younger folk, give a real physical thrill, a “shoot the chute” or near smash-up. Still others are designed to suit the more sober folk, and though thrilling enough for colder temperaments, do not contain that element of apparent danger so delightful to the younger generation.

A good example of this particular variety is pictured on the opposite page. The scene depicts a quiet little seaport in England. It is entitled “The Aerial Night Attack,” and represents most



At Coney Island a Zeppelin Raid Has Been Staged. General View of a Seaport Town in Which the News of an Approaching Zeppelin Has Been Received. Aircraft Are Dispatched to Meet the Invaders and They Mount in Great Spirals to the Sky

# Staging a Coney Island Zeppelin Raid

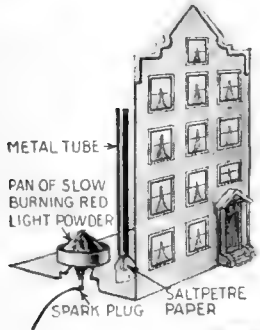
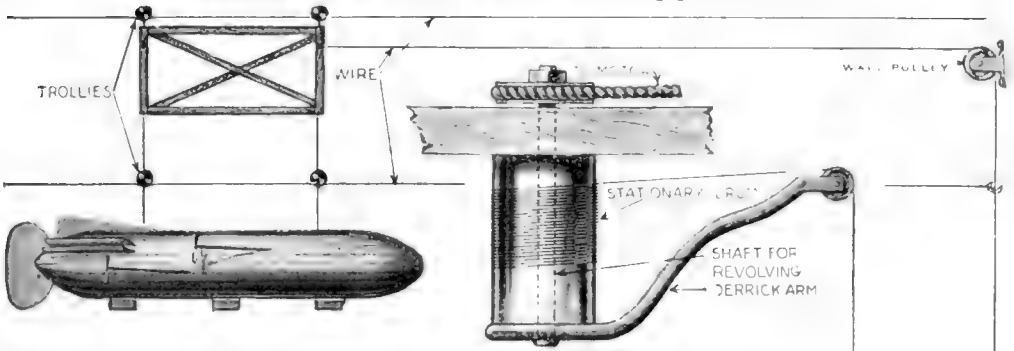

This Device for Hoisting the Aeroplanes and Revolving Them at the Same Time So as to Make Them Rise in a Realistic Spiral Consists of a Stationary Drum Attached to a Beam Set High Above the Stage and at the Bottom a Derrick Arm Which is Revolved by a Small Motor. The Saltpetre in the Metal Tube and the Red Light Powder Back of the House-Front are Ignited as the Bomb is Dropped and Give the Effect of an Explosion and Conflagration Inside of the Dwelling

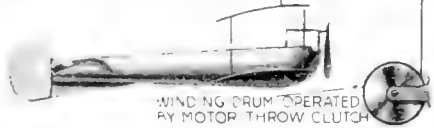

The Mechanism Which Gives the Impression of Distance. The Operator's Cage and Switchboard are Seen in the Upper Right-Hand part of the Illustration. The Placing of the Searchlights is Indicated at the Left of the Picture. In the Tank Which Represents a Harbor, a Small Steamer is Floating in the Wings Until the Proper Moment for it to Appear

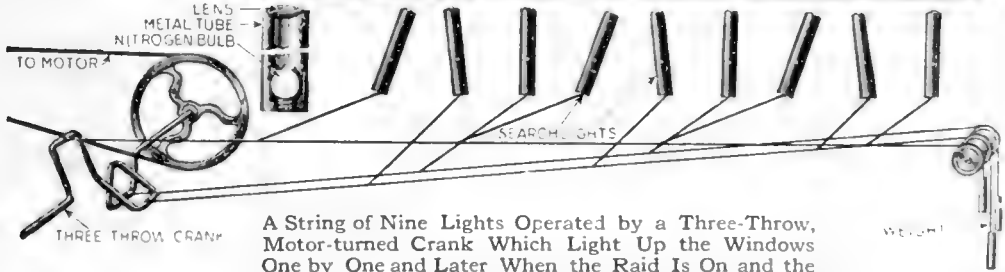
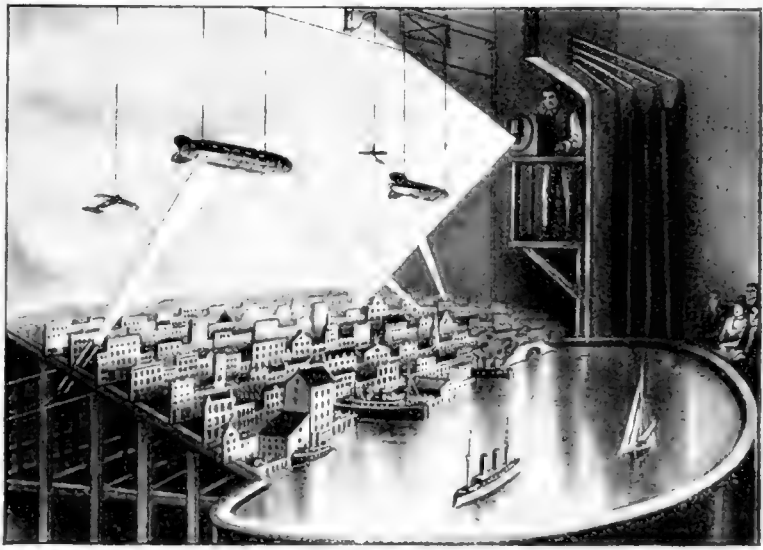

A String of Nine Lights Operated by a Three-Throw, Motor-turned Crank Which Light Up the Windows One by One and Later When the Raid is On and the City is in Darkness are Used as Revolving Searchlights

Below: Plan of Interdependent Sprockets and Chains. One Sprocket of Each Series Is Connected by a Shaft to the Corresponding Sprocket of the Other

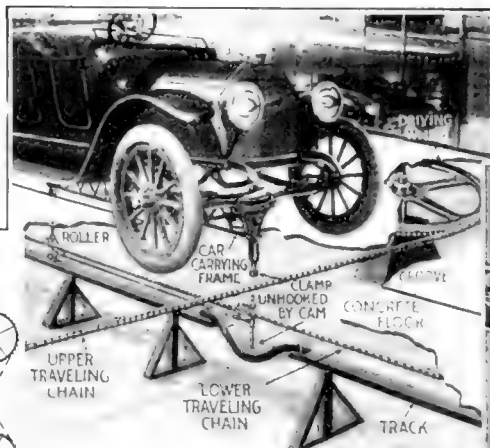
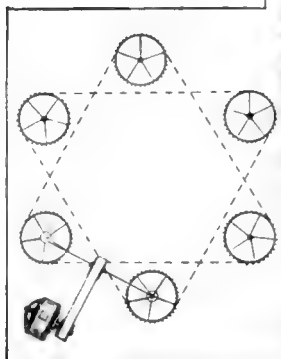

A Roller on Each Clamp Runs on a Track Placed Beneath the Chain and into a Cam Which Lowers It



The Automobiles Operated by the Lower Chain Are Attached to This Chain by Movable Clamps Which Permit the Chains to Pass One Above the Other Where the Tracks Cross

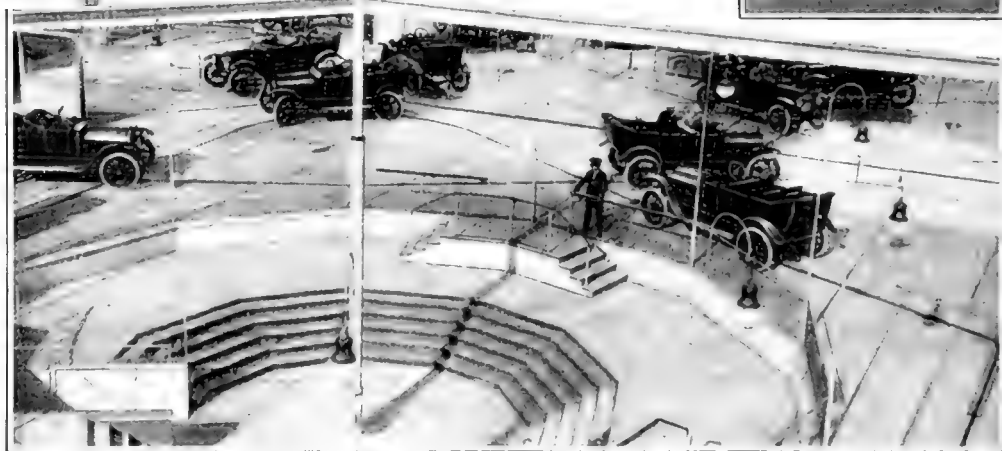

In "The Auto Maze" There Are Two Sets of Automobiles Speeding in Opposite Directions on Two Intersecting Triangular Courses. The Cars are Operated by Two Chains Under the Floor and Driven by Twenty-Foot Sprockets. A Collision Seems Almost Inevitable

faithfully a town which actually underwent several nocturnal raids. The representation is so good that many, familiar with the town, would immediately recognize it.

The advent of the airships, which drop murderous bombs on the inoffensive little town, makes the spectators feel that they are really present at the raid.

The other form of thriller, designed for purely physical thrills, is well represented by the next figures.

Have you ever been in an automobile smash-up? If you have, you know what

it feels like, but if not you can get all the excitement with none of the actual danger. In this latest "thriller" the impression given is that a serious smash-up is inevitable. The speeding cars approach each other at right angles, and, just as a collision is about to take place, the cars glide gently by with several inches to spare. The safety of the device is assured by the very complete yet simple mechanism pictured. Simplicity is really the keynote of a device of this nature; complication means unreliability and possible danger.

# The "Spinning-Wheel" Gun

THE "spinning-wheel" gun is the newspaper name which has been given an odd engine of destruction.

The gun consists of a wheel of aluminum and copper construction, mounted on ball-bearings supported by a suitable frame. Projectiles are placed in pockets in a groove in the rim of the wheel, which is rotated at a high rate of speed by an electric motor to which it is belted. The projectiles are automatically released by a mechanical device and hurled at the object at which they are sighted.

The new gun has many obvious faults, any one of which renders it worthless as a weapon of warfare. In the first place its operation necessitates the use of electric current which makes field service practically out of the question. Even with an ample electric current supply on hand the wheel could not be rotated with sufficient velocity to hurl the projectiles any appreciable distance. It has been figured out that a speed of at least eighteen thousand revolutions a minute would be needed to throw a projectile one thousand yards. It would be difficult to get a motor or bearings which would stand such terrific strain.

The "centrifugal gun" would necessitate the use of spherical projectiles, whereas the type which has been found most efficient is long and tapered and has a pointed end.

The gun is designed to supplant hand grenades.

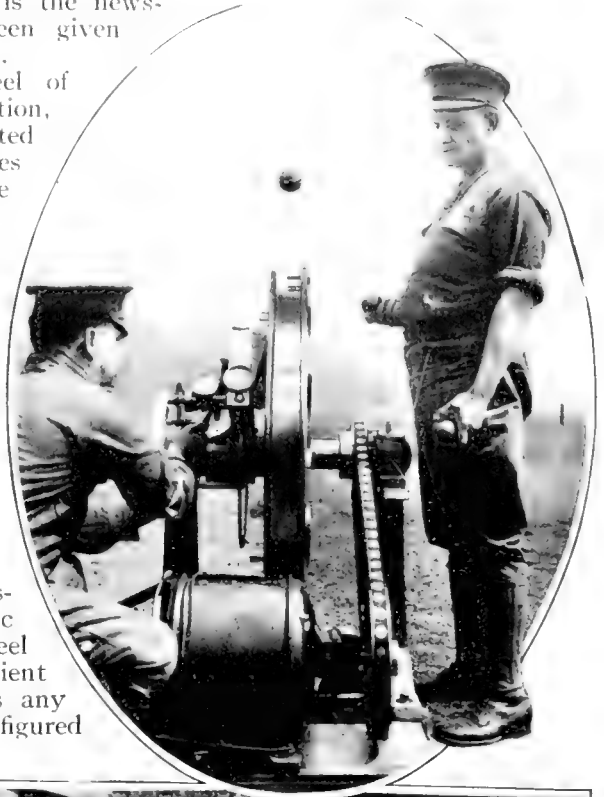

The Gun Consists of a Wheel Constructed of Aluminum and Copper Mounted on a Frame and Rotated at High Speed by a Motor



# Checkers as an Out-Door Sport



The Dark Squares Are Patches of Grass Showing Through Cut-Out Holes. The Checker Disks Are Shoved from One White Square to Another



Dr. A. George Goldstein Illustrating the Moves and the Ordinary Rules for Playing Out-door Checkers

A RECENTLY invented game called Lawn Checkers, which is sponsored by Christy Matthewson, is being popularized at the Prospect Park Tennis Courts, in Brooklyn, N. Y., and tournaments are being arranged by Dr. A. George Goldstein. The game is played on a 12-foot canvas "board" stretched out on the lawn. The squares are the size of an ordinary table napkin, and the alternate colors are green and white. The green squares are simply square holes cut out of the canvas at the proper intervals. The checkers are red and blue aluminum disks, one side of each being adorned with a star to represent the king or queen. The disks are shoved from one square to another by means of a long bamboo stick.

Teams of from two to twenty may play matches, each player being allowed thirty seconds to make a move. The ordinary rules of chess are followed and prompting is strictly forbidden.

# Fighting Infantile Paralysis

**N**EW YORK CITY has been fighting an epidemic of infantile paralysis. More than two thousand five hundred have contracted the disease and six hundred have died. Health authorities of nation, state and city assisted by eminent specialists in children's diseases, including Dr. Simon Flexner, head of the Rockefeller Institute, and Dr. Noguchi, the Japanese specialist, have joined forces in fighting the scourge, which, for the last twenty-five years, has baffled the medical profession.

The disease has been confined largely to the New York district, although a score of other states have reported child victims. The part played by the metropolis to keep down the death rate and to clean up every possible spot that might breed germs of infection has been instructive. Every department of the municipal government is co-operating with the Mayor, the Red Cross, the city's physicians, an army of nurses in addition, and federal authorities. Health Commissioner Emerson has called out New York's one thousand "home guards"—citizens trained under police direction for public duty in time of crisis—to join in the crusade.

The motion-picture theaters have been barred against children, as have the public playgrounds and recreation piers. One of the large film companies has issued fifty prints of a special release on the subject which will be exhibited in all the theaters and on motor-trucks equipped with translucent screens. A lecturer from the New York Board of Health accompanies each of the trucks and lectures to parents as the film pictures are projected on the screen. At first, when the plague was confined to New York City, the film company planned to give the illustrated lectures only in local



He Has Heard That His Safety Depends Upon Keeping His Surroundings Clean and He Looks as if He Means to Do It

districts but this plan has been altered and the prints are being sent all over, even to Melbourne, Australia, where the theaters have been closed because of the epidemic there too. As a precautionary measure the New York City Health Department has its nurses making house-to-house canvasses. Other acts of prevention are the nightly washing of streets in the infected districts, the exclusion of all household pets from sick rooms, careful screening from flies and insistence upon the utmost cleanliness.

It is the belief that the disease was introduced from Southern Italy by immigrants fleeing from the war zone. The first cases reported in New York City were in an Italian section near the Brooklyn waterfront, where the epidemic of 1907 first

appeared. Then the mortality was approximately five per cent; the present rate is about twenty per cent. In 1907 the victims numbered two thousand five hundred.

What makes the situation the more serious is the fact that medical science does not know how the disease is carried. In scarcely one case out of eight hundred has it been possible to trace the source of infection. A few years ago it was announced that the stable fly transmitted the malady. But in Buffalo, during an epidemic, this theory was disproved when districts thick with flies were comparatively free from the disease.

Formerly extreme dryness and heat were given as a cause. However, the Buffalo plague occurred during an unusually wet summer. In an epidemic on the Pacific Coast it was discovered that coincidentally there was an outbreak of lame colts. The two could not be connected, however. Deputy Surgeon W. C. Rucker of the United States



Keeping Clean Is Equivalent to Keeping Cool and the Street Gamins Thoroughly Approve of the Idea of Frequent Baths

Health Service, states that in Cincinnati he saw paralyzed chickens and ducks around homes in which were infantile paralysis cases, but again there was no way of connecting one type of victim with the other.

At present the tendency is to attribute the disease to dust germs. When infected with particles of dust found in the rooms of paralysis victims monkeys

Parks, Playgrounds and Recreation Piers Where Children Congregate Are Closed and Families of Children Are Segregated as Much as Possible in Their Own Districts

soon die. The Rockefeller Institute is now carrying on elaborate experiments along this line, and there is some hope that the mystery may yet be solved. Fifty thousand dollars in one cash prize awaits the man who solves it.

Dr. Flexner, who has succeeded in isolating the organism of infantile paralysis, says it is an infectious and communicable disease which is caused by the invasion of the central nervous organs—the spinal cord and brain—of a minute, filterable micro-organism which has now been secured in artificial culture and as such is distinctly visible under the higher powers of the microscope.

"The virus of infantile paralysis," says he, "exists constantly in the central nervous organs and upon the mucous membrane of the nose and throat and of the intestines in persons suffering from the disease; it occurs less frequently in the other internal organs, and it has not been detected in the general circulating blood of patients."

# Staging the Celluloid Thriller

By George F. Worts

GOING to the bottom of the sea for motion-pictures was accomplished for the first time about two years ago by George and Edwin Williamson, brothers who invented and perfected an undersea motion-picture apparatus. Their apparatus for making photographs under water was fully described in these pages at the time. But the results they obtained then cannot be compared with the results they have obtained in a photo play which has been in process of filming during the past year in the waters of the Caribbean near Nassau, Jamaica.

*Jules Verne and Daniel Defoe on the Screen*

They took a most difficult subject for their scenario. It was a composite story based on the most usable parts of Jules Verne's "Twenty Thousand Leagues Under the Sea" and Daniel Defoe's famous "Robinson Crusoe."

When the picture was first contemplated, Stuart Paton, the director, thought that he would borrow a submarine from the United States Navy for the parts of the story in which Jules Verne describes the submarine. The United States Navy was not especially enthusiastic about lending a submarine, and it was discovered that Jules Verne's submarine had very little in common with the submarine of to-day.

Accordingly a submarine was built especially for the picture. It took six months to build, and when it was finished it could dive, rise to the surface and shoot a regulation torpedo. The deck of this unusual craft had one hatch and

a very stunted conning tower. In shape only did it resemble the U-boat of to-day. It was engineless. It was submerged by means of inlet valves, and it came to the surface by forcing out the water with compressed air which was carried in tanks. Thirty men comprised the crew. In the bottom of the hull a hatchway (an air lock) was provided, so that the crew in their diving-suits could climb out upon the ocean bottom. The maximum diving depth was about forty feet.

The ocean and its inhabitants provided a great deal of excitement and danger. Most of the time the ocean was rough, too rough for taking pictures. Most of the dramatic action of the film took place on the ocean floor of the Caribbean at a depth of about thirty feet. The water near Nassau was found to be so clear that artificial

lighting was not necessary. In the older Williamson undersea picture artificial lights were frequently needed. Since then, however, the apparatus has been considerably improved, and faster camera lenses have also been found.

The Williamson apparatus, it will be recalled, consists of a large collapsible tube suspended from the bottom of a barge. At the bottom of the tube is a camera chamber provided with a window. The camera-man sits with his camera behind this window. In rough weather the barge would roll and the chamber and its occupant would swing back and forth. This motion of course prevented picture-taking. The tides furnished another serious handicap. On

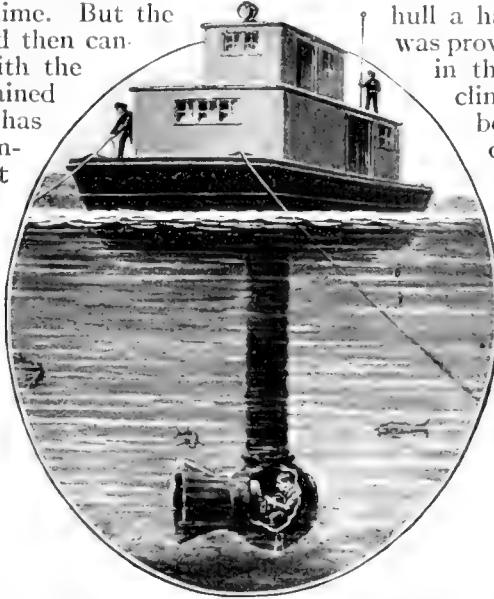

It Will Be Recalled That the Williamson Apparatus Consists of a Collapsible Tube Suspended from the Bottom of a Barge

## Twenty Thousand Leagues Under the Sea

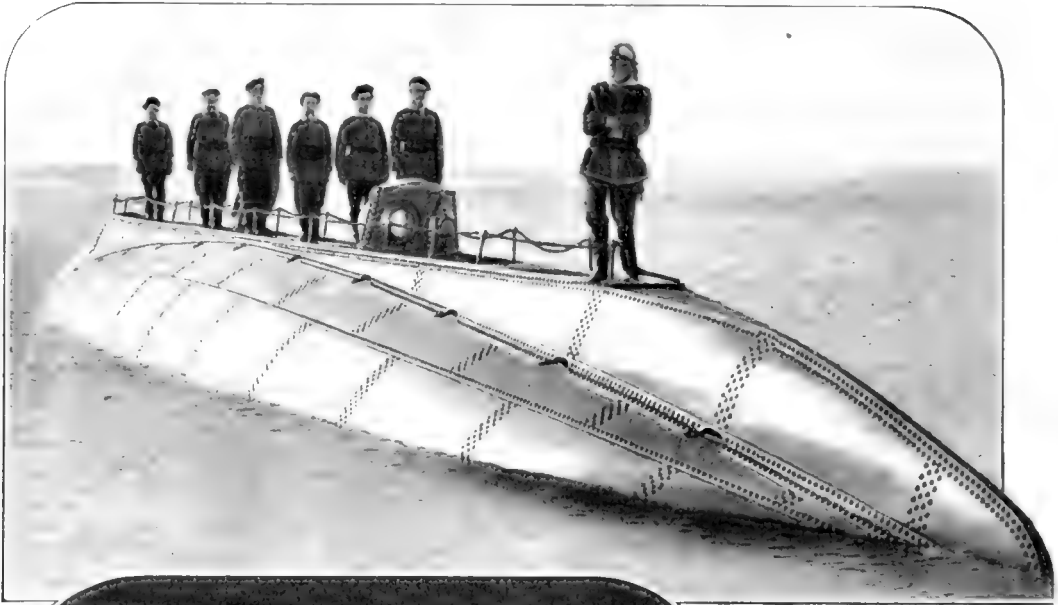

The Twentieth Century Submarine Has Little in Common with the One Jules Verne Imagined; So Six Months Were Devoted by the Wonderful Motion-Picture Magicians to Perfecting One (Illustrated Above) to Fit into the Scenes of the Story. When Finished It Could Dive, Rise to the Surface and Shoot a Regulation Torpedo. It Carries a Full Crew of Thirty Men

In the Bottom of the Hull of the Barge a Hatchway Is Provided, So That the Crew in Their Diving Suits May Lower Themselves to the Ocean Bed. In the Illustration a Diver Is Shown Returning to the Submarine by Way of the Hatchway. Note How Little His Self-Contained Diving Suit Impedes His Movements Owing to Its Very Light Weight

## Staged at the Bottom of the Ocean



Above, the Gruesome Spectacle of a Burial at the Bottom of the Sea. The Actors Were Provided with Tanks of Oxygen and Air Enough for Thirty Minutes

Below is Shown the Williamson Cinema Apparatus Which Has Been Greatly Improved Upon Recently by the Inventors to Present a New Photo Play

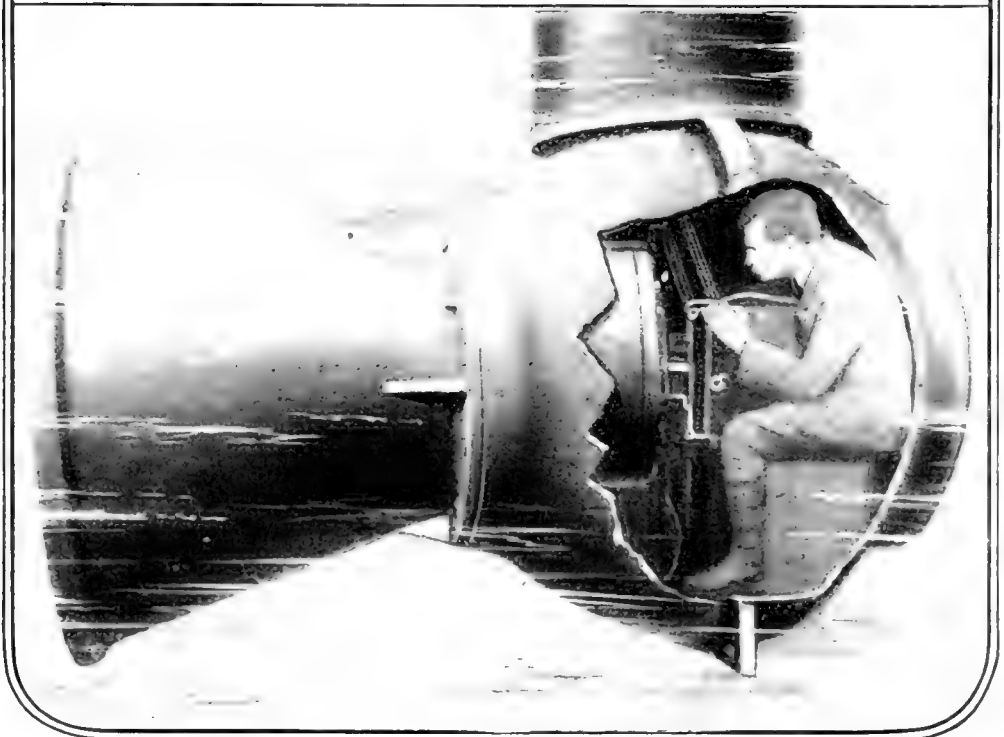



The Lower Plane Was, in Reality, Stationary, Being Suspended by Strong but Invisible Wires Between the Two Cliffs. The Upper Machine Swooped Down on the Lower One in Mid-Air, Dropped a Bomb Upon It and Destroyed It

vicious. Barracouta in swarms, or schools, would attack the men, and could be driven away only after a fierce battle.

#### *Love-Making at the Bottom of the Sea*

many occasions the actors in their heavy diving-suits were swept out of the camera's range. Other dangers not stipulated in the scenario were provided by curious and investigating giant fish. The divers succeeded in breaking one age-old tradition. They found that a shark could be frightened away very easily. Another fish, the barracouta, gave them more trouble. The barracouta is long, slim, swift and exceedingly

Not only were fights with barracouta and fights between men staged on the ocean floor, but many of the dramatic events of the story took place there. A rubber-clad hero wooed his rubber-clad heroine. A burial took place, and treasure was hunted and found. In fact, as many of the features of Verne's story as could be consistently were reproduced.

The actors were dressed for the underwater scenes in diving-suits, which were provided with tanks of oxygen and air





The Camera-Man Being Directly Under the Hurling Car, Caught It As It Flew Through the Air. It Came Near Crashing Down Upon Him and a Gathering of Curious Ones, But the Heroine Was Unhurt. Why? For the Good Reason That She Wasn't There

sufficient for thirty minutes' work.

Perhaps the most familiar thrill which finds its way through the flickering lens is the automobile smashup. One of the most thrilling feats in which automobiles have figured on the screen this year took place in California recently, when a motor-car in which the heroine was hastening to her hero, speeded over a

camera-man, being directly under the hurtling car, caught it as it flew, meteor-like, through the air. And it nearly crashed down upon him!

The car flew seventy-five feet. It just happened to alight right side up, so that the girl might just as well have stayed in. But that would have been contrary to the new code of thrills which

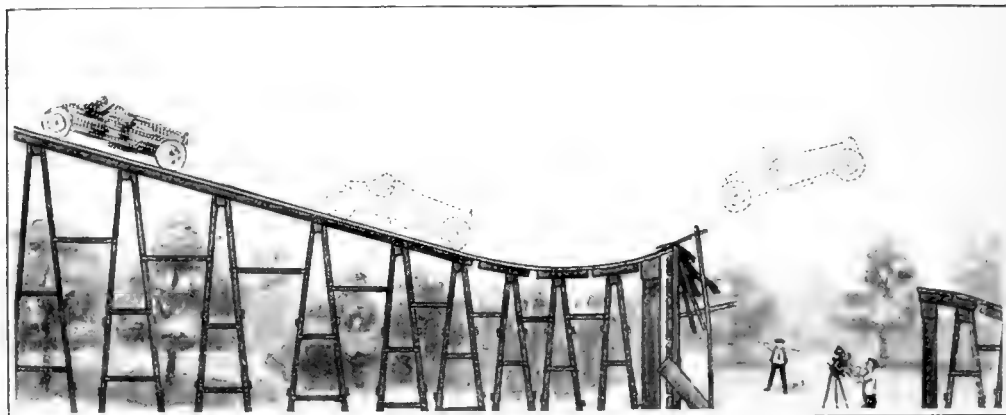

The Automobile Was Backed Up a Considerable Distance and Was Pointed Directly Toward the Gap, After Which the Steering Wheel Was Locked and They "Let Her Go!"

broken bridge and leaped through the air to the ground seventy-five feet away. There was really danger in this picture; danger, not for the heroine, but for the man who was turning the camera-crank. The bridge was carefully smashed up previously and the central part taken out. The approach was built up much after the fashion that ski runways are prepared in order that the skiers will fly into the air when they strike the runway.

In the picture as it appeared on the screen, the girl dashed down the roadway, unaware of the fact that the bridge was destroyed. Indeed, she drove the car at high speed almost to the approach. In the mind of the audience, that car kept on going, with the girl inside, and leaped the gap. In reality, she got out of the car when she had stopped it at the bridge approach. Then the car was backed up a considerable distance down the road, it was pointed, or aimed, directly at the bridge and the steering wheel locked so that the car would not swerve. It was started—gained speed, dashed out upon the bridge, hurtled over the gap and came crashing down to earth very much broken up. The

industry (shall we say "art?") has adopted—Let thrills be as they may—safety first.

#### *Sacrificed to Make a Motion-Picture Holiday*

A motion-picture company recently "staged" a costly picture in which one aeroplane swooped down upon another in mid-air, dropped a bomb and destroyed it. While the lower plane which was two hundred feet above the ground, seemed to be moving at a fairly high speed, in reality it was stationary, being suspended by strong but invisible wires between two cliffs. It seemed to move because the movie camera was mounted on an automobile which was moving rapidly below it. The narrow focus of the camera lens prevented either of the cliffs from being shown.

The feat is interesting also for a tragic reason. When the airman in the upper plane dropped the bomb, he was directly above the destroyed plane. The explosion forced an air wave upward which unbalanced the moving plane, it toppled over and the aeronaut was crushed to death in his fall.

# An X-Ray Tilting Table

After the Patient Is Once on the Table He Remains There Until a Complete Examination Has Been Made and Radiographs Taken

At the Rear of the Table There Is a Tube Carrier Which Moves Automatically with the Screen at Which the Physician Is Looking

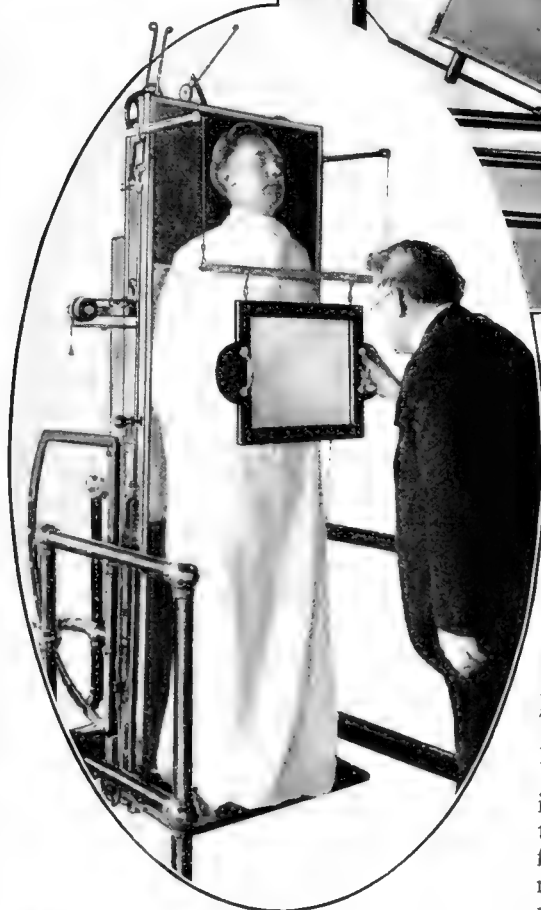
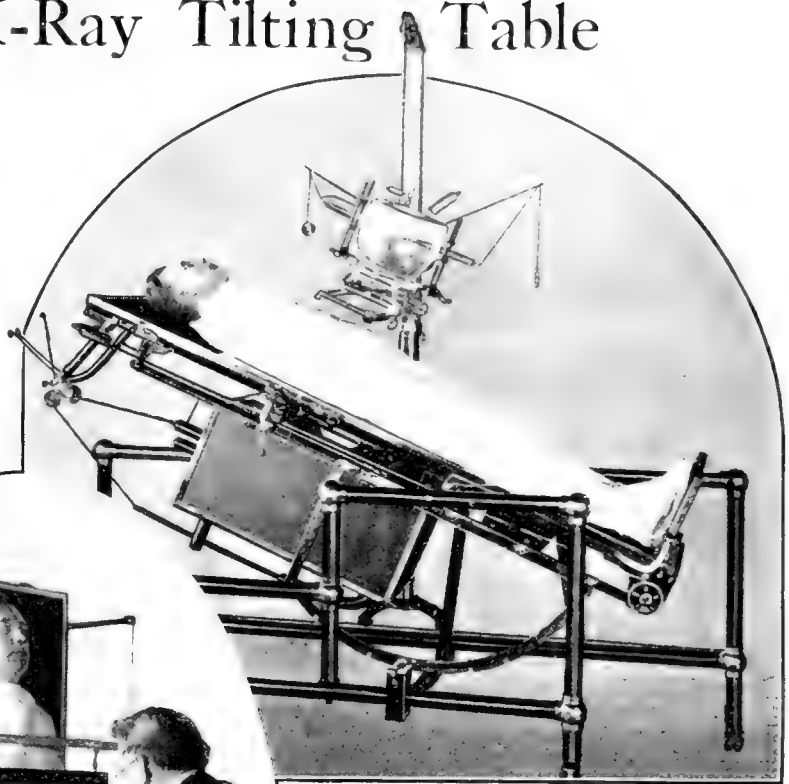

invented by Claude E. Campbell, of Lynn, Massachusetts. The device combines in one compact mechanism several pieces of apparatus.

One of the accompanying photographs shows the table as used for fluoroscopic examination of the patient, who is standing between the fluoroscopic screen and the table. At the rear of the table is a tube carrier which moves automatically with the screen at which the doctor is looking, making it possible to examine the patient's trunk without moving him. The patient and the operator are protected from the X-Ray.

In the other illustration, the patient is shown on a table tilted down for taking an X-Ray photograph. For the fluoroscopic examination, the screen—not shown in this picture—would be placed over the patient. For making a radiograph the plate would be placed under the patient and the current thrown in the tube holder above the patient.

The table can be tilted and locked at whatever angle may be most convenient.

**X**-RAY photographs of patients in all possible positions to suit the various conditions with which the physician or surgeon has to deal are made conveniently with a "tube tilt-table,"



The Photographer in His Aeroplane Can Point the Pistol-Camera with Great Accuracy at the Object To Be Photographed. The Two Focusing Frames Take the Place of Sights on a Revolver. The Trigger Operates the Shutter

#### “Shooting” a Photograph with a Pistol-Camera

OF the number of aerial cameras which have been designed to meet the requirements of modern reconnaissance work in the present war perhaps the most novel and interesting apparatus is a pistol-camera used by German airmen which is now in the possession of the French. Jean Navarre, a daring young French flier who brought down his fourteenth German aeroplane early in April, found the camera in an Aviatik which he forced to descend within the French lines in the Soissons neighborhood.

The camera was intact and in working order. In fact, there was reason to believe that it had been used the same day it fell into the hands of the French, although no plates were exposed. Several were in position, however, ready to be exposed. The pistol-camera has the shape of an enormous pistol, and looks unwieldy because of its large size and grotesque shape. It has a pistol grip and trigger similar to that on all makes of revolvers.

The shutter of the camera is operated by pulling the trigger. The photographer points the apparatus with dead accuracy at the object to be photographed and with a slight movement of his finger takes the picture. The two focusing frames, which are nothing more than common gun-sights in disguise, enable the photographer to level his camera with absolute certainty.

The length of the camera box is a little under two feet, and its weight about thirteen pounds. The French have tested the photographic capabilities of the apparatus by experimenting with it in their own aeroplanes. Excellent results were produced. In some cases clear and distinct photographs of military value were taken at altitudes of upwards of six thousand feet. This camera is the only one of its kind to fall in the hands of the French.

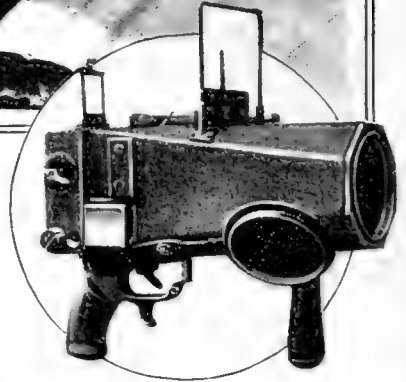

The End of the Cleaner Is Moistened by the Enclosed Benzine a Drop at a Time

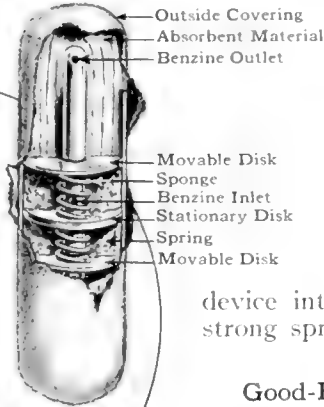
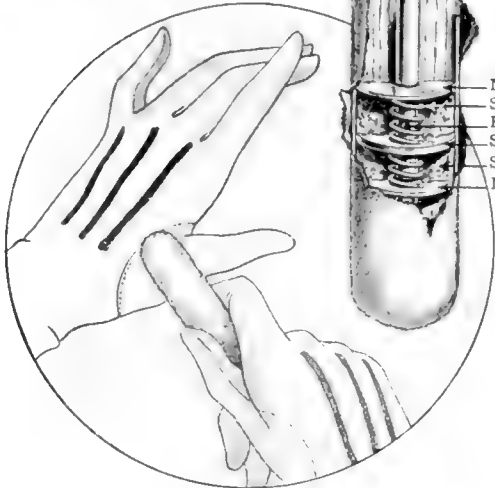

**Cleaning Gloves Economically with Benzine**

A GLOVE cleaner which contains its own benzine is illustrated. A metal tube holds a sponge in its upper part and felt or some other porous material in its lower part. The whole is surrounded by a covering of fabric.

The device is pressed down on the glove. This drives in the felt and pushes down the disk, compressing the sponge and causing liquid to pass through a small hole into the tube and out through a second hole. In the middle there is a fixed metal piece which separates the device into two similar halves. Two strong springs separate the parts.

**Good-By to the Pin-Boys in the Bowling-Alley**

A NEW kind of bowling-alley has been invented by Joseph M. West, Rockport, Missouri. The bowler throws a ball suspended from a trolley carriage which travels on an elevated guide-rail. It is merely necessary to pull a lever to cause a resetting ring to push the pins back into upright position. The ball is automatically returned to the bowler without the services of the pin-boys. A perfectly accurate floor, the expensive feature of an alley, is not essential.

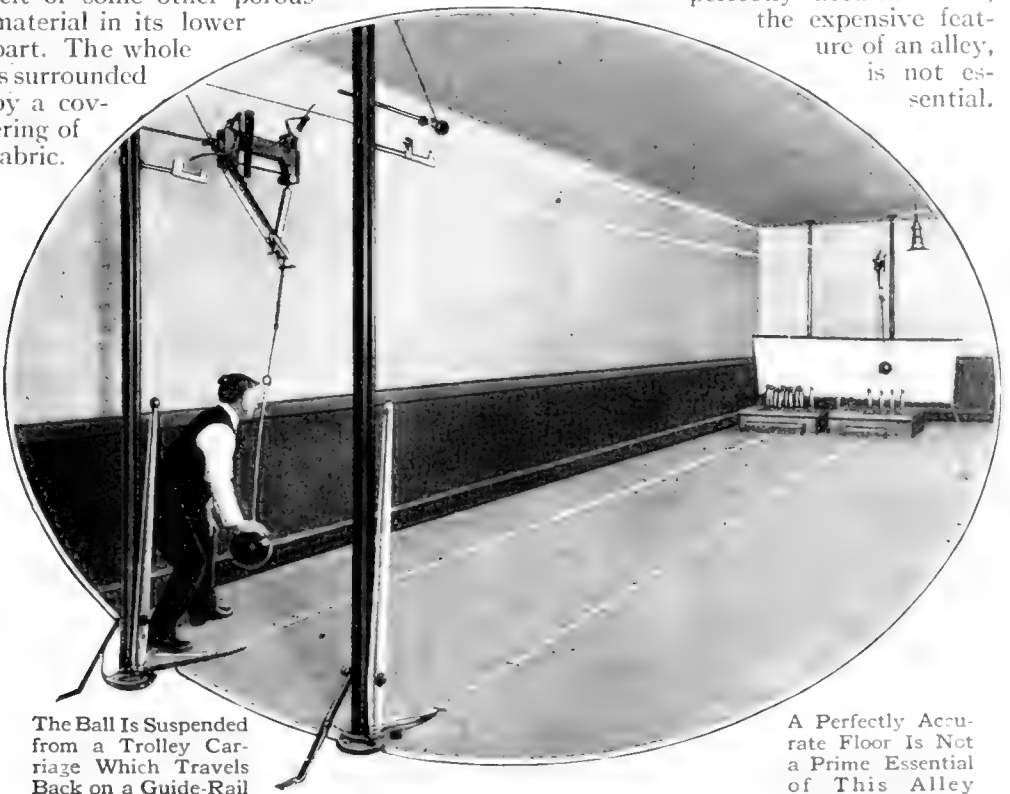

The Ball Is Suspended from a Trolley Carriage Which Travels Back on a Guide-Rail

A Perfectly Accurate Floor Is Not a Prime Essential of This Alley



Trilby, of Lincoln Park, Chicago, Gets Her Nails Trimmed Only Once in Six Months, But That Is Enough, According to Her Manicurist, and Too Often for Trilby

### When Manicuring Nails Is a Dangerous Job

**M**ANICURING a lion's toe-nails is a man's job, especially when the patron is a man-eating lioness with a recent killing to her discredit. The illustration shows Cy De Vry, head animal man at Lincoln Park, Chicago, cutting the toe-nails of Trilby. A week previous to this Trilby was known as a docile creature particularly attached to her keeper, Emerson Dietrich. In one day her reputation changed from a lioness with a kitten disposition to the most ferocious creature in captivity.

The transformation took place when Trilby was alone in a box-car with Dietrich. With no apparent warning the beast became ugly and attacked the man, tearing at him with such fury that he was unable to beat her off. Before he could summon help the lioness had killed him and had already started in to eat up the car. When Trilby's toe-nails were manicured she raged and fought the men, but a pike pole and a rope soon reduced her to a submissive state.

### A Garden Tractor Which Does Everything But Mind the Baby

**A** GARDEN tractor designed to take the place of horse and man-power in the cultivation of garden and truck crops has been placed on the market by a Minneapolis company. In addition to its usefulness as a tractor, the machine also serves as a portable engine.

The machine can perform twelve distinct and widely varying operations; among them, running a washing ma-

chine, churning, mowing lawn, running an emery wheel, sawing, operating a cream separator and turning a fanning mill. It can be applied to almost any small task where a gasoline engine may be used. Primarily, however, the tractor is designed for small crop cultivation, in which work it is said to excel in every particular the former and time-sanctioned method of cultivation by horsepower.

The operator of the machine walks behind and steers it as one guides a lawn-mower.

There is no necessity for expenditure of energy in handling the tractor as it pulls itself along at the rate of from one to three miles an hour. The machine is capable of two thousand two hundred revolutions a minute when it is attached to another machine by means of the connecting belting and pulley attachment. It weighs four hundred and fifty pounds and is made especially heavy to insure traction.

The Old and New Methods of Harrowing in the Cultivation of Garden and Truck Crops

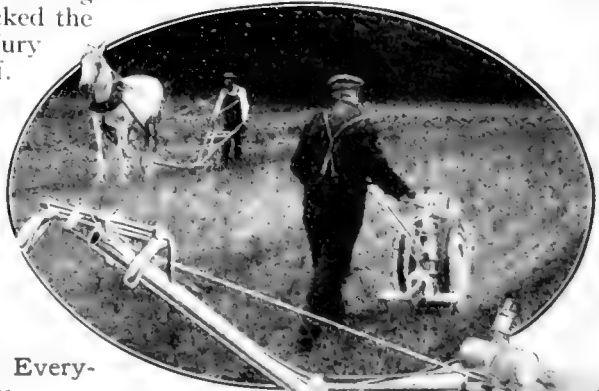

The Machine Also Serves as a Portable Engine

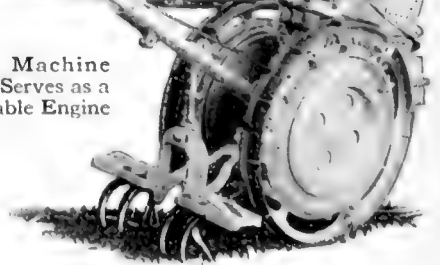

# Blowing Concrete Into Place

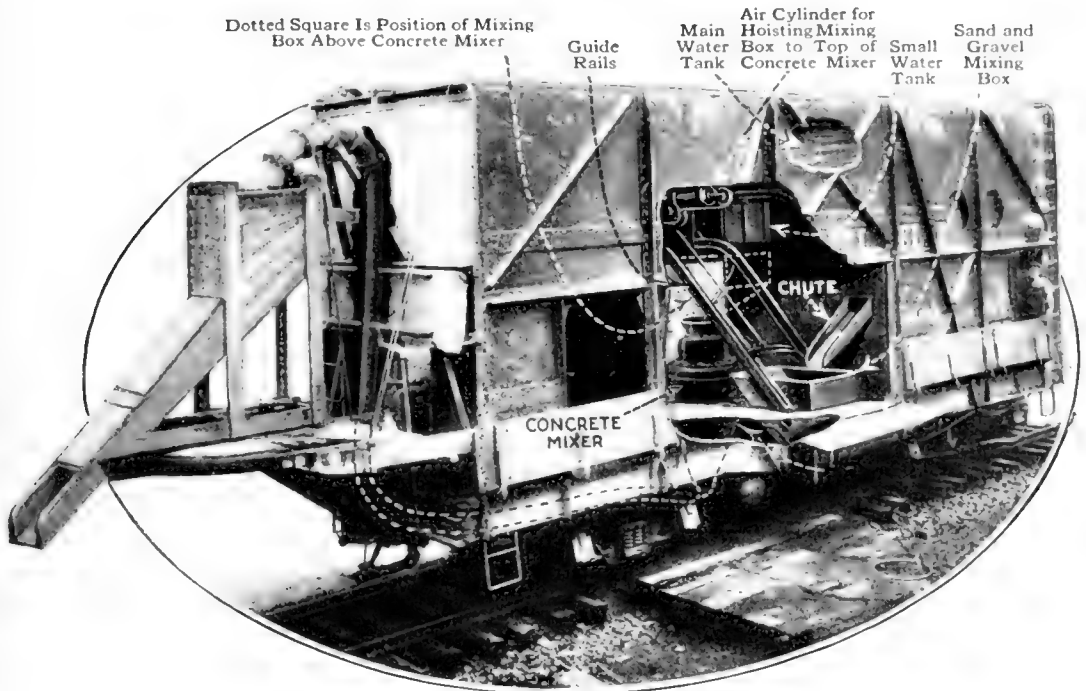

A Specially Constructed Steel Car Which Conveys Concrete at the Rate of Fifty Feet a Second by Utilizing Compressed Air. The Car Propels Itself with the Aid of a Gasoline Equipment

**A** NEW system for conveying concrete to the place where it is to be used employs compressed air and the concrete travels at the rate of fifty feet a second. It is especially applicable for lining tunnels with concrete. The mixing may be done outside the excavation and the concrete conveyed by a pipe line to the point of use. Or, to cite a recent instance on the line of the Carolina, Clinchfield & Ohio Railroad, the mixing may be done on the spot upon a movable car.

It was desired to put the concrete lining into Sandy Ridge tunnel near Dante, Va., without shutting off the railway traffic through it. The concrete required amounted to some 50,000 or 60,000 cubic yards. A steel car was specially constructed, and provided with a gasoline equipment by means of which it could be made to propel itself. Half way between the ends is located the mixing compartment—open on both

sides of the car. At a higher level, extending the whole length of the car, are located the stone bin, the water tank and the sand bin. The water is immediately above the mixer compartment. The two end bins have inclined bottoms sloping towards the mixing chamber where they deliver the sand and the stone by suitable chutes. The gasoline engine is located at one end of the car beneath the sloping bottom of one of the bins. Beneath the sloping bottom of the other bin is placed the air receiver and the bags of cement. When the supply of compressed air runs low, a fresh supply may be taken from an air main running through the tunnel.

The mixing chamber contains two principal pieces of apparatus. One is the mixer itself, placed on one side of the car. The other is the charging skip. Its permanent place is on the other side of the car between the two chutes. When these chutes have delivered their



materials and the cement has been dumped in by hand, the skip is hoisted by compressed air and made to dump its contents into the mixer. Inclined rails guide it from its permanent place to its transient position above the mixer. Compressed air is used to perform the mixing, the conveying and the placing.

The conveying is a short affair. A suitable pipe takes the concrete from the bottom of the mixer beneath the car and up to an elevated position at one end of the car. Here the pipe divides into a Y, associated with which is a sliding plate to control the movement of material into either arm. One arm of the Y is used when placing concrete in the side walls and foundation; the other, when placing it in the arch.

#### Motor-Trucks to the Rescue in a Freight Embargo

THE great value of motor-trucks for overland haulage was brought out recently when a convoy of five vehicles and three trailers hauled a total load of forty-four tons of steel from the customs warehouse in New York city to a manufacturing plant in Hartford, Conn., a distance of one hundred and forty-four miles. The steel had arrived from Sweden but could not be shipped to Hartford by rail because of the difficulty in obtaining freight cars. The plant was almost out of material and was facing a complete shut-down until a motor haulage contractor in New York city agreed to deliver the goods overland. His convoy, consisting of five 5½-ton motor-trucks and three 5½-ton four-wheeled trailers, left New York at 5 P.M. one night and arrived at Hartford at 11 P.M. on the following night. During the first night the drivers

took four hours of sleep apiece, stopping and lying down on the seats of their cabs, for the total load was very valuable and insured for \$100,000 by both the consignee and the haulage contractor. If it had not been for the motor-trucks, there is no telling how much the plant would have been inconvenienced.

#### An Electric Motor-Chair

THE electric motor-chair shown in the illustration has such a wide variety of uses that it seems destined to become very popular. It may be used by invalids and by convalescents in hospitals; as a pleasure vehicle on board walks; for trips in the parks; for giving the children little outings; and even for shopping and for a calling car. Its operation is so easy and so nearly fool-proof that there is very little danger of accidents.

The chair develops a speed as high as ten miles an hour, but can be adjusted for lower speeds. An electrical appliance prevents higher speeds when going down hill. The fender serves to prevent serious accidents when running into obstacles; for as soon as it touches an object the circuit is broken, the power shut off, and the brakes automatically applied. The chair is guided and controlled in the same manner as the electric automobile.

It may be elaborated and provided with a wind-shield, top, and side curtains. When fully equipped it weighs about four hundred pounds. The batteries may be charged at any garage or other place where the ordinary storage battery is charged. In fact, except for its style and its fender mechanism, it is very similar to the ordinary runabout.



The Motor-Chair Develops a Speed of Ten Miles an Hour

Balanced Rock, in the Garden of the Gods, is So Perfectly Poised That Formerly Two People Could Sway It. Now It Is Cemented Firmly in Place

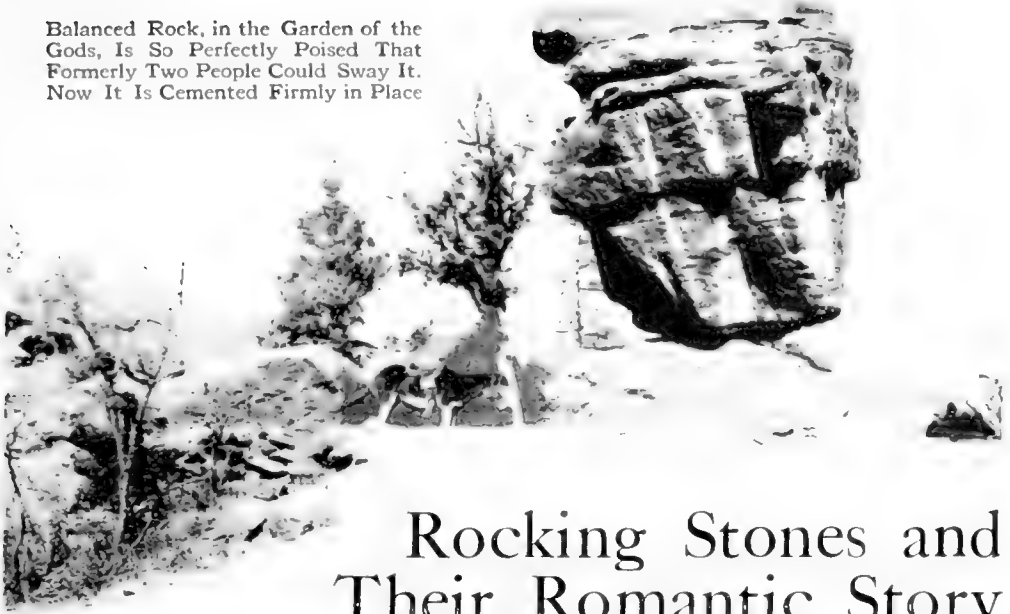

## Rocking Stones and Their Romantic Story

IN some of the accompanying photographs are to be seen three different kinds of rocks, perched by Nature one on top of another. How could they have been placed in such positions? They weigh many tons.

Millions of years before the coming of the first man on the earth, the two top detached boulders were gently placed in their present resting places by the hand of a veritable giant—the North American glacier. During the Great Ice Age the whole of the northern portion of the United States was covered hundreds of feet deep with glacial ice. A glacier is snow, which, by melting and intense packing, is formed into solid ice banks. But the glacier is a constantly moving ice mass. It travels slowly but with enormous grinding and carrying power, down the slopes and valleys.

A mass of ice several hundred feet thick, constantly replenished at its source, and sliding down a mountain slope with a weight of many tons to the square foot must have been well-nigh irresistible. That such was the case is illustrated by the many enormous boulders which were picked up from their original moorings by the huge glaciers of the Ice Age and transported many miles before they were deposited by the melting of the ice.

Without this now well established

explanation of glacial transportation it would be impossible to account for the queer positions in which boulders are often found as well as for the intermingling of entirely different kinds of rocks in the same place.

In one of the photographs the upper boulder is a rock about five by eight by eight feet, of coarse Massachusetts granite. It is securely perched on a different kind of rock of nearly the same size—a rock known as a gneiss. Both are resting on a granite ledge, but of a different texture from that of the upper granite rock. Even assuming that the two granite rocks were alike, without knowledge of glacial action, it would be difficult to account for the presence of the middle boulder weighing at least ten tons.

Nowhere in the United States are the evidences of the tremendous force of the great glaciers of the Ice Age more striking than in the Sierra Nevada of California. Rugged V-shaped mountain gorges have been scoured and smoothed out into broad U-shaped valleys by the great descending ice masses. The dirt and rocks have been spread about on the plains below or at the mouths of the canyons, while the glacial scratches and furrows can be plainly seen on the remaining rocks in

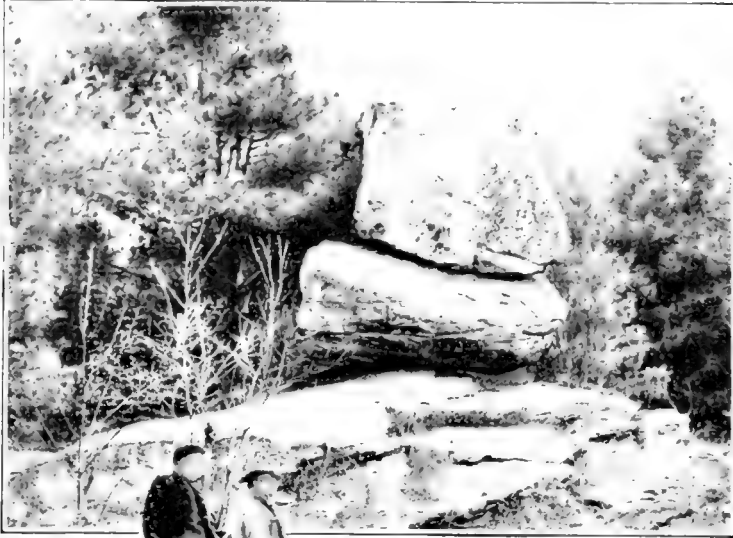

The Upper Boulder Is of Massachusetts Granite. It Is Resting on a Rock of Gneiss, and Both are Perched on a Granite Ledge of Different Texture From That of the Upper Granite Rock

At Left Below, A Rock Transported and Deposited by Huge Glaciers from the Sierra Nevada. This Rock will Outlast Its Base Many Thousand Years



Below, An Erratic Rock Fragment Resting on a Big Base, Brought to Its Present Position by an Agency Powerful Enough to Transport It Over Irregularities in Land Surface





Above, A Perched Granite Boulder Left on a Sandstone Base by a Glacier Which Melted on a Slope of the Famous Yosemite Valley, California. The Sandstone Pedestal Is Greatly Weathered and in a Hundred Thousand Years, Perhaps, It Will Wear Away and Precipitate the Heavy Boulder Into the Canyon Below



At Right, The Large Boulder Which Serves as the Base Is Rapidly Wasting Away While the Smaller Boulder on Top of It—Weighing a Ton or so—Shows No Signs of Deterioration, Although It Has Probably Rested in This Position For the Better Part of a Thousand Centuries or More

The photograph with the man standing beside a rock shows a perched granite boulder left on a sandstone base by a glacier which melted on a slope of the famous Yosemite Valley, California, a vast gash in the Sierra Nevada, now believed to have been largely cut out by glacial action. Since the boulder was so deposited it has changed but little. The sandstone pedestal, however, is greatly weathered and in the natural course of events, in a few hundred or a thousand years perhaps, will further disintegrate. Then the boulder will be precipitated down the steep slope of the gorge into the canyon below.

What are now the beautiful Tuolumne Meadows of California were formed by billions of tons of rock and soil, including many great boulders as large as houses, which were transported by glaciers from the Sierra Nevada. Most of this material has been formed into soil and grass, trees and running streams all to make a beautiful natural park. A few great granite boulders still remain to be a witness to the might of a glacier which melted away long ago.

One of the pictures shows a large boulder which is beginning to disintegrate, while the smaller boulder—weighing perhaps a ton—is perched on top of it, having rested in this position for probably the better part of a thousand centuries. Another of the photographs shows a large erratic boulder resting on a rock outcrop in Mono Valley, California. Undoubtedly it was transported to this point from the nearby Sierra at a time when the ice streams flowed strongly down the eastern

slope of this range to levels much lower than those reached by the feeble glacier remnants now existing near the summits of the range. This boulder could have been brought to its present position only

by some agency not now present and one that would disregard topography, riding over irregularities in land surface and leaving erratic rock fragments perched in positions to which water could not transport them.

The famous Balanced, or Rocking, Stone of the Garden of the Gods in Colorado was deposited in a similar way by the glaciers of the Rocky Mountains. It is a stone of very large dimensions, and so exactly does it balance that until lately it could be swayed easily.

The continual rocking to which it was subjected by thousands of tourists ground away the base to such an extent that to preserve it as a curiosity it was cemented in place.

#### One of the Pranks of the San Francisco Earthquake

**A**BOVE is one of the crevasses caused by the earthquake which almost destroyed San Francisco. Earthquakes are always terrifying events, but they are only excessively destructive of life and property in case the territory affected is thickly populated and highly improved. At this uninhabited point the great earthquake of 1906 resulted only in a natural curiosity, but imagine this rift occurring beneath the business block of a prosperous town! In another place a quarter of a mile of wagon road was bodily removed ten or twelve feet from the rest of the road.



A Typical Crevasse Caused by the Earthquake Which Demolished San Francisco

Even the Hornets Have New Ideas Sometimes

**E**IGHT hundred miles up the Amazon River, in South America, a hornet's nest was found recently which is unique in the annals of wasp architecture. It is constructed of clay, put together not in tiers after the custom of wasps, but in a solid mass, the weight of which may be judged from the accompanying photograph in which the nest is shown suspended on a stick and requiring both hands of the exhibitor.



The Sun Has Baked This Wasp's Nest Until It Is as Hard and Almost as Heavy as if It Were Made of Stone

The rounded wall is unusually thick and a question arises as to how the tiny builder came to the conclusion that the best way to keep his house cool in that torrid temperature was to put as much solid cement between its interior and the sun as he could get. He evidently figured, also, that his body would require less space if he slid into his home lengthwise than if he flew straight in, in the usual way. He tried it out, anyway, making his doorway just a long, narrow slit through which his slender body could pass easily enough but which would be burglar-proof to almost any kind of marauder daring to attempt invasion.

Rolling, Harrowing and Seeding With One Machine

**A**N internal combustion engine takes the place of horses in driving the combined roller and harrow invented by an Indiana man. With the machine a field of growing grain can be rolled without uprooting it by the travel of horses' feet. One or more harrows can be combined with the rolling implement, or may be omitted from it, according to the work to be done. A seeding attachment is provided at the forward end

of the machine. Cloverseed, for example, may be sowed broadcast by the seeding attachment, the seed rolled into the soil, and then harrowed to prevent the surface from becoming encrusted. Or the operation of the machine may be varied for other seeds, soils, and conditions.

The direction of the travel of the implement may be reversed and the soil harrowed, rolled and the seed sown upon the rolled surface. The machine does the work of four horses and two men at a cost of one and one half cents an acre. Clover and

grasses can be saved by rolling them down with the machine while the ground is still much too soft for horses to walk on.

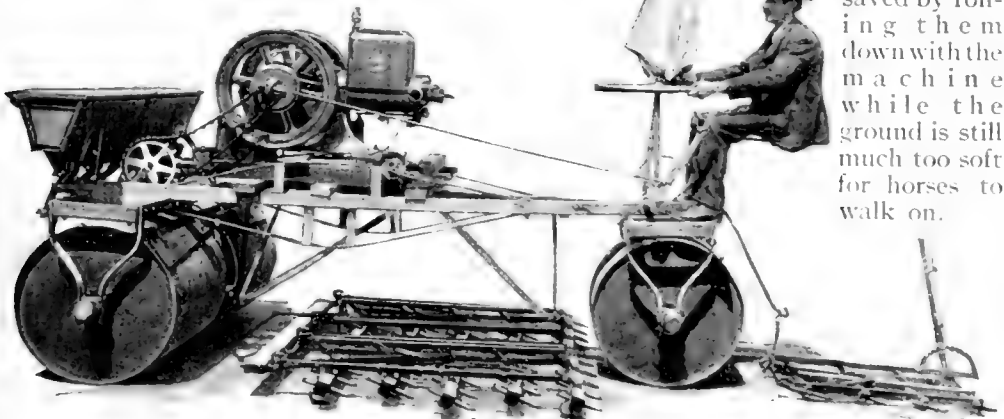

The Combined Roller and Harrow Which Does the Work of Four Horses and Two Men at a Cost of One and One Half Cents an Acre, to Say Nothing of the Time Saved

# Safeguarding the Sand Blaster

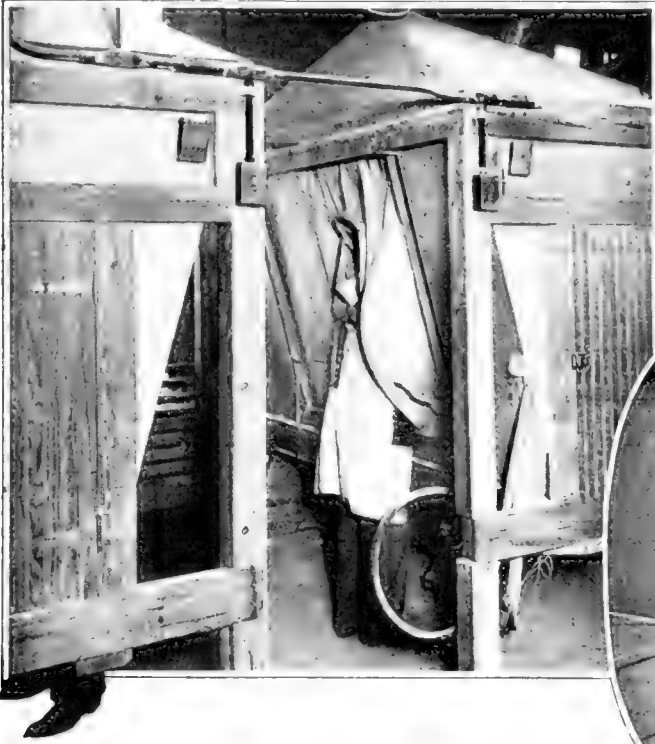

At Left, the Hopper Where the Workman Operates. A Strong Suction Saves the Sand and Draws Off the "Flour" So Dangerous to the Lungs

The Head-Dress Allows a Free Passage of Air About the Head and Through the Fine Copper Gauze Which Protects the Eyes: The Hands Are Heavily Gloved



**T**HE preparation of metal surfaces for a covering of paint has given rise to the extensive use of sand blasting outfits. When these are constructed of sufficient capacity to accommodate large surfaces such as are presented by automobile guards, hoods and bodies, the problem of protecting the workmen presents some difficulties.

Fine quartz sand is sprayed against the metal surfaces, causing a certain amount of disintegration of the particles of sand into a powder as fine and volatile as flour. This sand flour is very penetrating, and many ingenious devices in the form of head-dresses are now in use to protect the face and lungs of the operator. The familiar helmet with its sponge through which the operator breathes is adapted for this purpose. On account of the cutting properties of the sand, glass cannot be used, and the substitute is an exceedingly fine copper gauze giving the necessary range of vision.

Such devices are only partially suc-

cessful from the standpoint of protection, and can only be relied upon when built in the form of a diver's head-dress and supplied with fresh air under pressure. Operations were first conducted to cover the larger detachable sheet metal automobile parts such as dust shields, fenders, hoods, etc., and after many experiments, the device, as illustrated, has successfully solved the problem.

The container is of the familiar hopper type, with a strong suction both over the top and underneath, carrying only the heavy particles of sand flour to the bottom of the hopper, where they are collected and again drawn through the air-suction hose. In this way the sand is used over and over again, and only the flour is drawn off. Fresh sand is introduced through the large door at intervals, each unit caring for its own sand supply. The work is introduced by



a helper through the large door, and the operator has his head and arms strapped into a head-dress constructed so that the curtain forms the front of the hopper. This curtain is attached to sliding metal doors moving horizontally, allowing the workmen to move from side to side at will by the pressure of their elbows upon the metal leaves.

The head-dress is constructed to allow a free passage of air about the head and through the fine copper gauze into the sand blasting department. The strong suction in the sand blasting department sets up a sufficient vacuum to cause

the fresh air to circulate around the head of the workman and the copper gauze into the sand blasting department. This affords a constant supply of fresh air for the operator, while the inrush of air clears the copper gauze and assists the vision of the operator. In practice the amount of fresh air drawn through this head-dress is so great that the workman wears a shield on the back of the head as a protection from the draft.

In operation a considerable economy is effected through the use of a much smaller system of exhaust and dust collecting. Less sand is required and the total saving of power and material is increased. A battery of twelve of these outfits is at work in an open room, and no discomfort is experienced by either the operator or others working in the vicinity. The same principle is applied to sand blasting automobile bodies.

### Why Not Make Rain Work? A Chance for a Rain Motor

THERE have been numerous attempts at utilizing the energy of the sun and the tides, but it is doubtful whether the energy of rain has ever been considered. A little figuring, however, will convince one of the enormous force yet unharnessed.

One inch of rainfall is not uncommon in this country, yet every time this happens the earth is moistened with a paltry 113 tons of water to the acre, or 72,480 tons per square mile. The annual average rainfall the world over is estimated at



Sand Blasting Automobile Parts with the Modern Head-Dress. The Fresh Air Is Supplied Under Pressure

36 inches. Using this value and our first figure, we arrive at the astonishing result that the average rain falling on one square mile in a year is 2,609,280 tons in weight. How small is this figure, though, when we think of parts of British India where the precipitation is given at 610 inches.

A law of physics says that work equals force multiplied by the distance through which it acts. Let us consider the energy of all this weight of water falling from the clouds. The height of clouds is estimated at from two to three miles, but to allow for seasonal variation and the lower height of rain clouds let us take 2,000 feet. Using this figure we find that the average work done by falling rain in 24 hours is 22,320 foot-tons per acre—assuming our annual average rainfall of thirty-six inches distributed uniformly throughout the year.

All the specialized knowledge and information of the editorial staff of the Popular Science Monthly is at your disposal. Write to the editor if you think he can help you.

# Battle Ball—A New Sport

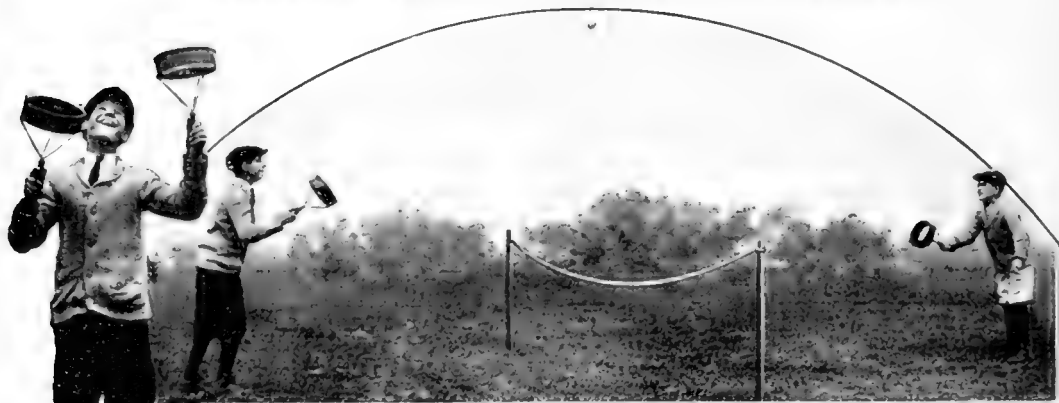

The Principle of the Game Is Almost Identical with That of Lawn Tennis, the Distinguishing Point of Difference Being the "Push" Motion with Which the Ball Is Struck. This New Game Is Just as Much Fun When One Person Plays It, Using Both Rackets, as with a Partner

**B**ATTLE BALL is the name given to a sort of first cousin to the popular game of tennis. It is a new outdoor game devised by a resident of Virginia. It is played with a racket of novel construction and cloth-covered rubber balls used in tennis. The racket is circular in form with a wide band across which the woven gut of the racket is stretched. The handle is positioned in alinement with the center of the band, to which it is attached by three wires. The rackets are less expensive than those used in tennis.

The game may be played by two or four players, or it may be played individually, offering an excellent means for exercise. If the player is adept the ball is thrown in the air from one racket and then caught by another racket as it falls, and bounced back and forth indefinitely. The game requires a degree of skill sufficient to make it fascinating.

## An Example of Motor-Cycle Dare-Deviltry

**A**MERICAN motor-cyclists are constantly keeping their English cousins amazed by the perilous feats they accomplish with their American-made motor-cycles. When the Boquet Siphon of the Los Angeles Aqueduct was finished recently a manufacturer of auto-

mobiles thought it would be a novel advertising trick to run his car on the siphon. It was a comparatively easy job to get the car on the pipe and when once there it was impossible for it to fall off. The driver could have fallen asleep with safety. Of course the photographs were disappointing.

But when a motor-cyclist came along and contemplated doing the trick people from surrounding cities gathered to see the event. Unlike the automobile, the motor-cycle had to pick its own way and that had to be done with the aid of handlebars in the hands of the driver. Harry Hartz was the driver. He mounted the pipe without fear and on his first trip kept his eyes on the track ahead. On the second trip, however, he looked behind him and actually closed his eyes.



Riding a Motor-Cycle on the Big Los Angeles Siphon. After Several Practice Trips the Rider Actually Performed the Dangerous Trick with His Eyes Closed

# Getting Ready for the Clay Birds

By Edward C. Crossman

A Scene at a Typical Trap Shooting Exhibition. The Man on His Knees Is Releasing the Clay Birds

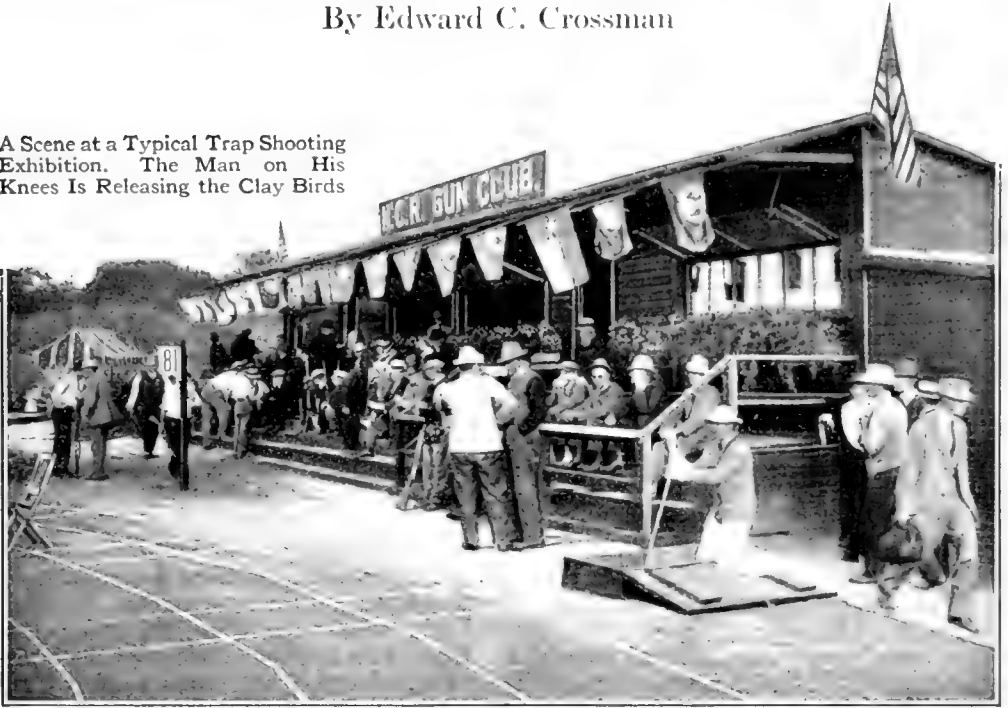

ONCE too often we trekked to the place of the flying saucers. The spell of the clay bird is upon us. And so, perforce, we toddle down-town to the mart of the gun sellers and there consider the guns that are suitable for breaking the clay.

By the rules of the game our task is a bit simplified. We may not under the rules use more than one and one-quarter ounce of shot. We may not use a gun larger than twelve-inch bore. By the rules of common sense, desiring to compete on equal basis with other clay bird devotees, we cannot go below this allowance. We need no such handicap, for a time at least.

Seeking a gun no lighter than seven and one-half pounds for the sake of our shoulder, we find spread out before us divers weapons, all of them represented at the grounds of the clay bird. The cheapest is a single barrel, single shot weapon, hammerless, cheap in finish, good enough to break clay birds, costing about fifteen dollars, but a little underweight. Unless our contemplation is to

use such a gun merely until we find ourself, it is not the gun to choose, because it is not quite adequate for the skilled shot. Next in price and most formidable in efficiency is the repeating shotgun of various makes. Thousands of them are in the hands of the most skilled trap-shots in the country. The weapon is not quite so simple for the beginner to handle as the double-barrel gun, and the reach to the slide-handle, by which the gun is operated, is a bit long for the short-armed man. The cost in plain quality runs less than twenty-five dollars. In guns with checked fore-stock or slide handle and checked grip, the cost is about thirty-five dollars. No better weapon is made for breaking the birds, but some people find that they shoot better with the double barrel. Does our choice fall on the repeating shotgun, then it must have barrel no shorter than thirty inches, stock with "drop" or crook from the line of the barrel no more than one and one-half inches at the comb and two to two and one-quarter inches at the heel, which is the



Waiting for the Boy  
to Release the Bird

upper end of the butt plate. The gun seller knows. This same restriction as to "drop" holds with any other gun we select.

The double gun is a most reliable gun used for trap-shooting, and so is the special single barrel, hammerless. A wise plan is to borrow from the kindhearted trap-shooters guns of both the pump,

or repeating, and the double type, and with them to sight at various objects to give us an idea as to which of the two types seems to suit us, individually, better.

### Selecting a Gun

If our choice is the double, then it should have, if possible, thirty-two-inch barrel and be of the stock dimensions laid out, and the stock for a person of normal build should not fall below fourteen and one-half to the front trigger, measuring from the edge of the butt-plate in the center of the stock. The gun also should have automatic ejectors—little hammers in the fore-end, which, when the gun is opened, kick the fired shell out of the gun without the aid of the fingers.

We want the butt-plate fitted with some one of the rubber pads made to take up recoil. The most commonly used is the sort that is glued firmly on as part of the stock. But before we do this we must make sure that the gun shoots as a trap-shooting gun should, and second, see that the gun fits us. The best plan is to instal on the gun temporarily

one of the cheap lace-up or slip-on rubber recoil-pads, costing about one dollar. This will make the stock longer, and usually we can use it longer than it is put out; because in trap-shooting, being allowed to have the gun to our shoulder, we can use a stock longer than we could in the game field, and the extra fraction of an inch adds to the steadiness of swing. If, however, there is too much of a good thing, shown by the greater control over the gun in shooting a few shots with the pad taken off, then we can decide that a shorter stock is correct, and so have the permanent rubber pad glued on, at the cost of about five dollars.

With the appointed gun and three sorts of trap loads, obtained from the obliging dealer, we obtain a dozen sheets of wrapping paper, not less than forty inches square, some thumb tacks, a tape of twenty-five feet or longer and seek in the country an old board fence or an old abandoned barn or board sign on which we can tack our paper. The trap loads should contain not more than three drams of smokeless powder, and one and one-quarter ounce of No. 7½ or 8 chilled shot. Three different makes of shell or three different brands of powder should be represented in the loads we take out.

### Testing Your Gun and Your Powder

First we cut open and count the pellets in one of the shells. The easiest way is to pour them into a box, shake them into



The Operator at the Trap Mechanism Below the Ground. Several Piles of Clay Birds Are Shown

even, parallel rows, count one row and multiply by the number of rows. As a rule  $7\frac{1}{2}$  will run 430 to the trap load, 8 will run 500 to 525. The  $7\frac{1}{2}$  is the best size, taking windy days and all into consideration.

Then we tape off just forty yards from the board, aim carefully at the center of the paper and fire a load at it. See that the gun apparently shoots straight—puts the center of the load where you aimed, or a bit higher.

With a fifteen-inch piece of string carrying a pencil at the end, we describe a thirty-inch circle around what is apparently the center of the "pattern," shown by the shot marks in the paper. Checking off each hole with a mark of the pencil, we count the marks in the magic circle.

The gun you want must put from seventy to seventy-five per cent of its charge into the circle. Set down your count, and divide it by the number of shot in the whole load. Seventy per cent of 430 is practically 300; seventy-five per cent is practically 320. Shoot several sorts of loads, and several shots with each load, counting and setting down the results of each.

If with any one load the gun shoots better than seventy per cent and shoots evenly, leaving no apparent "holes" or empty spaces much larger than the four and one-quarter-inch clay bird, it is all right. Submit the patterns to the gun seller.

He can advise you of their suitability for the clay birds. In this as in most games, the advice and guidance of the experienced shot is worth more than any printed page.

To back up, the gun shooter needs a shooting jersey, either without shell pockets and with a shell bag, or with special reinforced pockets to hold a box of shells between the two. Large shooting glasses of green or amber tint aid the vision and keep out stray bits of dirt or powder. A glove for the left hand, loose

and easy to slip on, is advisable. A cap beats any heavy felt hat. No "biled" shirt, no stiff collar, can be tolerated in the outfit of the trap shooter. The neck must be free and easy. A soft flannel shirt with tie, a neat Norfolk type of suit of neutral color, a cap, and a jersey make the best shooting clothes.



A Clay Bird Trap Operated by Pulling the Trigger. This Is the Most Common Form of Automatic Trap

### Learning How to Shoot

Nothing is more tiresome than the tyro in any game who expects to learn first principles by actually engaging in the game itself. The technique of a game, such as shooting or golf, can be acquired in other places than on the shooting grounds or the links and will prove less obstructive to those more advanced. Let the tyro practice at home with the *empty* gun containing an *empty* or fired shell to absorb the blow of the hammer, bringing the gun to the shoulder, bedding it firmly, cuddling the face down on the stock until the right eye looks along the rib at a height of two silver dollars laid flat on the barrel. At no time must the breech or the barrel obscure the

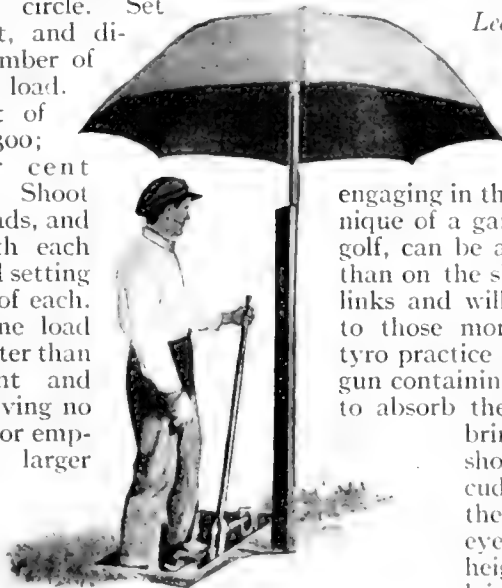

By Pulling a Lever the Clay Birds Are Shot Into the Air Forty Yards Away

vision; the eye must be above the line of the rib or barrel. At no time must the left eye be closed.

There is at times, the fatal presence of a "master left eye." One eye or the other does the guiding, the other or non-aiming eye merely aiding in the estimate of the distance and angle of the bird. If the left eye is the master eye then the remedies are four. One is to learn to shoot from the left shoulder: the second,

shot, fought this trouble for years with the shotgun and finally had to take to closing one eye with this weapon.

Some of the finest shots with firearms, rifle, pistol and shotgun, practice assiduously at home with the empty weapon. Why should the tyro feel that he can learn all there is to learn by actually firing?

Let him practice pointing the empty gun a little below horizontal as he would



A Night Scene at the Chicago Gun Club Where Some Famous Shoots Have Been Held

to make the right eye the master by persistent practice at the right shoulder with both eyes open; the third, to have the stock made to fire the gun from the right shoulder but crooked so as to bring the barrels before the left eye, and the fourth, to close the left eye at the instant of aiming, which is done by some trap-shots but should not be done unless it is imperative through the left master eye.

The quick and infallible test is to hold up a finger-ring at arm's length and to gaze through it with both eyes open at some distant object. Without moving it, close the left eye and see if the right is still gazing through it. Reverse this, still without moving the ring. Repeat several times. The master eye will be found looking through the ring every time, and the other eye will see the ring off to one side apparently several inches.

If the gun is shot with both eyes open from the right shoulder, with the left eye the master, the left eye will infallibly drag the muzzle over between itself and the bird, putting the gun entirely out of alinement and making the shooter miss the bird to the left. The lady of the writer's family, a fine rifle and pistol

at the edge of the forward side of the trap-house, say "pull" to himself, and then swing rapidly up after the imaginary bird, pressing the trigger when the gun reaches what he feels is the right spot. A black spot on a white wall, a generous spot like a one-inch black paster at a distance of a dozen feet, is right. If he is standing at the imaginary No. 3 peg, which is just back of the center of the trap, then the birds can come out at any angle within forty-five degrees of the straight line before him to the imaginary trap.

#### *How to Handle the Gun*

First he must learn the fixed, glued relation of face, hands and gun stock. All movements in trap-shooting are done from the hips. Read this again, and study it. The position of face on stock is the rear sight of the gun. Regardless of any field experience or of any beliefs, the tyro must glue himself into an immovable relation with the gun after it comes from the shoulder. If he swings after a bird, the swing must be from the hips; the face, hands and stock must not change relation until the shot goes. If

he raises after a bird coming up out of the trap and going straight away, he must not perpetrate the invariable trick of the beginner—raise his head from the stock; but he must make the move one of the whole body, the face, stock and arms not changing relation.

Time is the most important part of trap-shooting. The tyro must learn to fire in the same time, and that quickly. This means that the shot must go before the bird has started on its downward curve, and the sooner the gun can be brought on the bird, the better. The instant the bird goes the gun must swiftly and smoothly swing after it—not jerk after it—catch it, and then the trigger must be pressed without stopping the motion of the gun. Straightaway birds are hit as a rule by pressing the trigger just as the muzzle comes to the lower line of the bird but without stopping the upward swing. Quarterers are hit by a swift swing by them and a release of the trigger when the gun is from a foot to three feet ahead, depending on the speed of the swing, which in turn depends on the individual.

The birds leave the trap with the initial speed of one hundred and fifty feet a second and cover the shooting distance with the average speed of one hundred feet a second. Shot takes the seventh part of a second to travel forty yards, which is about the distance at which you would fire at a bird. The seventh part of one hundred is practically fourteen and one-half feet, and so, while our shot is travelling forty yards, the bird is getting nearly fifteen feet. If it is a quartering bird to you, angling across your line of fire, a little paper and figuring will show you plainly enough why you cannot shoot *at* a bird of the sort and hit it. All motions must be smooth and speedy, not the convulsive jerks of the typical tyro, nor yet the slow poky aim of other tyros. Practice at home, first.

From any of the big powder or ammunition or gun companies you will be given printed matter on how to organize a gun club, on how the purses in tournaments are split, where to find your nearest club if you do not know where it is, and all the small points of the game.

Another illustrated article on trap-shooting by Mr. Crossman—"Hunting the Mud Pigeon," it is called—will appear in the October issue.—EDITOR.

#### A Modern War Relic

THERE are few towns in the eastern half of the United States that cannot boast of at least one antiquated cannon ball, a relic of the Revolutionary War or of the Civil War; but Quantico, Va., is perhaps the only community that can boast of a modern fourteen-inch steel projectile that fell in its midst.

Quantico is about ten miles below and on the opposite side of the Potomac River from Indian Head, Md., where the United States Navy tests the big guns for battleships. To deter-

mine their penetrating qualities, shells are fired at armor plate set up before a sand bank several hundred feet from the guns, but when tests are made to study the performance of the firing and recoil mechanism the guns are elevated so as to drop their

shells in the middle of the Potomac River, several miles below. Fast motor boats patrol the river to keep vessels out of range.

Quite often the shells hit the water at an angle which causes them to "skip." A short time ago the "skipper" shown landed in Quantico.

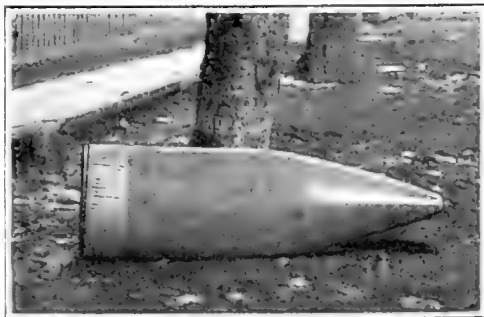

This Steel Projectile Weighs 1,250 Pounds. It Killed a Cow and Damaged Houses



# Smoothing Sidewalks by Machine

**A**N outfit for roughing stone sidewalks has been perfected and placed on the market by an Illinois company. It consists of an air-cooled air-compressor driven by a gasoline engine mounted on a light steel truck.

The compressor is a vertical, air-cooled, oil-splash lubricated machine connected to the engine by a coupling. The compressor valves are

of thin flexible sheet-steel and cannot be drawn into the cylinder.

The tool is an ordinary plug drill fitted with a case-hardened steel block with sharpened raised points which do the work. In chipping around cracks and posts set into the sidewalk a trimming tool is used. An unloading device furnished with the compressor keeps the air at the correct pressure for the most efficient work. The block has a wire handle which helps to guide the tool.

The entire outfit is operated by one man and the work is done expeditiously and thoroughly. The truck is made somewhat on the order of a boy's express wagon except for the fact that it is of steel. The machine is equally adapted to use on stone or cement walls or interiors wherever roughing is required, the pressure being uniform whatever the position or angle.

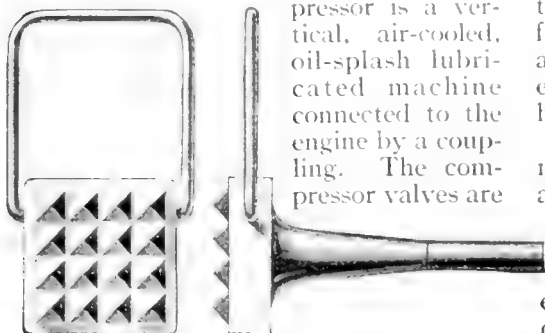

The Tool Is Fitted with a Case-Hardened Steel Block with Sharpened Raised Points

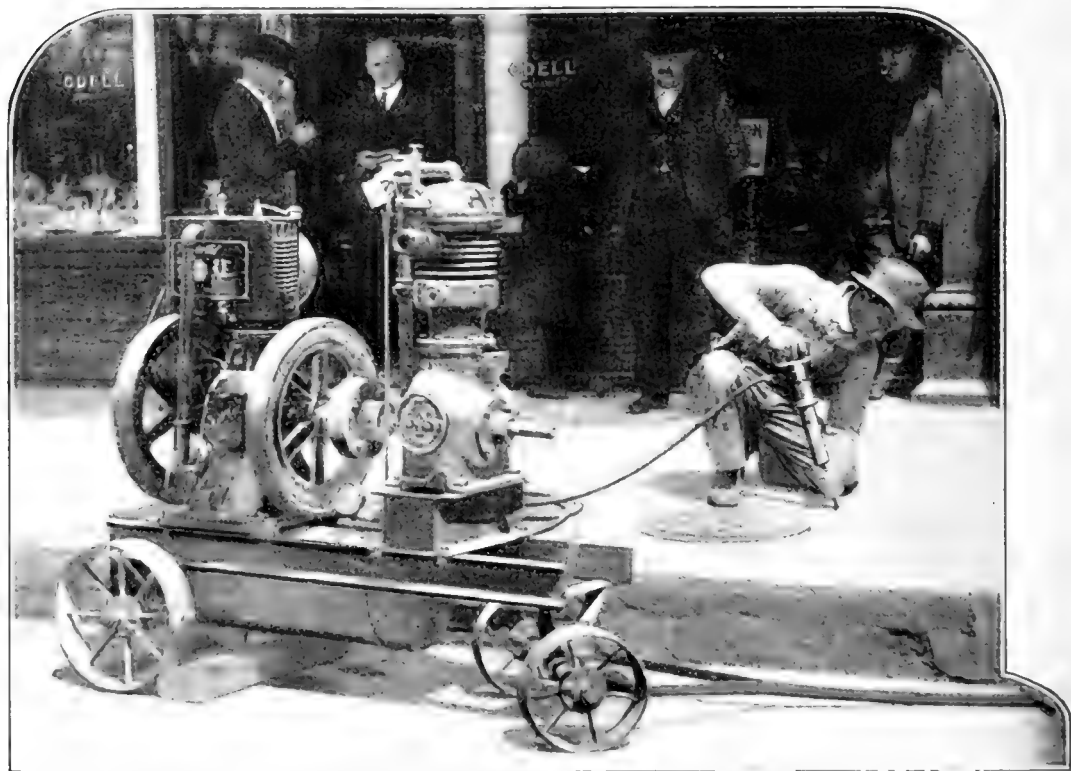

The Outfit Consists of an Air-Compressor Driven by a Gasoline Engine. In Chipping Around Cracks and Posts or Openings Set in the Sidewalk a Trimming Tool Is Used

# Secret of a Sun-Parlor Bedroom

**I**N modern apartment buildings a great demand has sprung up for apartments provided with sun-parlors readily convertible, by folding-beds and other convertible furniture, into sleeping porches without such double use

against the wall, bringing into position the writing desk. The bed is then folded in its upright position and the room is complete. When the room is to be converted from a sun-parlor into a bedroom the door is swung outward, bringing into



The Heavy Door Has a Chiffonier on One Side and a Desk on the Other. The Bed Can Be Folded Up to Form a Seat. Thus a Comfortable Bedroom Can Be Transformed into a Cozy Sun-Parlor

being obvious to the ordinary visitor. A Chicago inventor has taken out patents on a device he hopes will solve the problem.

The object of the invention is to so combine the walls of any room, used as a sun-parlor, with its own furniture and with an adjacent or supplemental room, that the desired result is achieved. A swinging door or partition provided with furniture for different purposes or of various characters attached to the opposite sides is used to transform the appearance of the room at any time.

In the accompanying illustration a bedroom is shown on the left and a sun-parlor on the right, being interchangeable by the simple means of a folding bed, and a swinging door equipped with a desk on one side and a dresser on the other. Regardless of the load of furniture the door carries, it cannot sag, due to its novel mounting. When the room is to be changed from a bedroom to a sun-parlor, the swinging door with the dresser attached is swung back

position the dresser; and the folding bed is lowered.

The room adjoining the sun-parlor or bedroom may or may not be partitioned off when the swinging door is opened.

## The Preëminence of American Inventive Ingenuity

**O**F the epoch making inventions of the world during the past fifty years, 48 in number, Americans are credited with 35, which include the telephone, typewriter, cash register, incandescent lamp, talking machine, electric furnace reduction, electrolytic alkali production, transparent photographic film, motion-picture machine, buttonhole sewing machine, carborundum, chain stitch shoe sewing machine, single-type composing machine, continuous process match machine, chrome tanning, disk plow (modern type), welt machine, electric lamp, recording adding machines, celluloid, automatic knot-tying machine, machine for making barbed wire, etc.



On the Island of Laysan in Oceania, Thousands of Albatross Live from November to January. The Island Is So Rarely Visited That It Is a Veritable Albatross Paradise. The Birds Are Splendid Flyers and Swimmers, but on Dry Land They Are as Clumsy as Geese. The Spread of Wing of Albatross is Seventeen Feet, and the Length of the Body Four Feet

The Albatross Breeds Between November and December. The Nests Are Mere Holes Dug in the Ground and Lined with Twigs and Grass. The Female Lays Only One Egg. In March the Old Birds Leave the Island. They Return in October and Drive Away Their Own Young—Which Have Grown Up into Strong Fighters in the Meantime

for Fertilizer and Eggs. Products of the Albatross



An English Company Is Exploiting the Island as a Source of Guano Fertilizer. A Ship Lands Periodically and the Eggs of the Albatross Are Gathered in Wheel Barrows. The Eggs Are Sold in Honolulu, Even Though They Are Not as Fresh as They Might Be

# A Six-Wheel Automobile

**A** MICHIGAN inventor has worked out a steering mechanism for four wheels of a six-wheel vehicle. His invention is unique in that it embodies no radical changes from existing methods now in use, but rather distributes the applicable use of those methods. He has found that there are special advantages in driving all four wheels where soft tires are used, as beyond a certain limit the tractive strain on such tires, especially pneumatic tires, is so destructive that it is impracticable to drive with two wheels for a load of more than four or five persons.

Furthermore, he claims that another advantage in a "double" or four-wheel drive where all four wheels are steered, is that the rear wheels always follow the track of the front wheels. In moving forward or backward, turning either to right or left, it is impossible for the rear wheels to get out of the track of those in front. If the front wheels clear an obstruction the driver knows that the rear wheels will clear also and need give them no concern.

In the accompanying drawing is shown a vehicle frame having six wheels. The front and rear wheels are steering wheels, which are deflected by the steering-lever. The centrally located pair of wheels are not steering wheels and always remain in the same planes relatively to the body. When the steering wheels are deflected to steer the vehicle to the right they will follow one another in circles, while the central wheels will turn as on pivots in circles a few inches within the steering wheel circles.

The interesting features of the mechanism are the hubs of the four steering wheels, the centrally located horizontal wrist-plate with which the steering rods are connected, and the T-joints on the central axle. The hub of each steering

wheel consists of a tubular body with which the driving axle is attached by a universal joint arranged in the central plane of revolution of the wheel, and permitting the wheel while receiving the rotating power of the driving axle to oscillate freely in every direction. The inner end of the tubular body of the hub engages with a sway-block having a horizontal slot sliding on the axle. This holds the wheel rigidly upright, while allowing it to oscillate to conform to the direction of motion of the vehicle.

The centrally located horizontal wrist-plate which is attached to the steering rods is composed of a cam-plate, a double cam-plate having a ball and socket bearing and numerous other accessories too intricate to

describe here, all of which give to the four-wheeled steering mechanism the advantages of a sensitive and automatically locked movement in all maneuvering required in steering on ordinary straight roads, and accelerated as it approaches extreme swing right or left.

To provide for unevenness in the road it is necessary to pivot the frame at the central axle. To this end the reaches are separately journaled with T-joints on the central axle, which permits any individual axle to move vertically and yet maintains the axle rigidly against lateral movement.

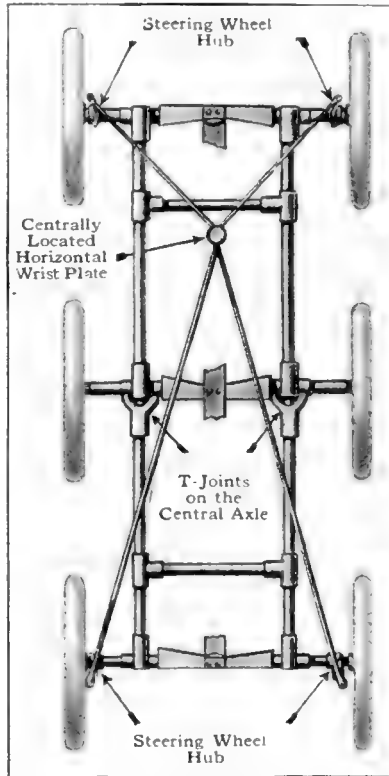

How the Four Wheels of a Six-Wheel Automobile Are Steered

# Plenty of Room for All Europe

THE United States can swallow all of Europe—area, population and all—as will be seen in the accompanying map, which shows in a vivid manner how wide is the expanse of the country we live in.

The entire combined computed area of the foreign countries noted on the map and the area of the western United States are very nearly the same. The discrepancy is a bare fifteen thousand

more than fifty-one millions of people accommodated within its boundaries.

More striking, however, is corpulent Idaho with its three hundred and twenty-five thousand inhabitants living in an area sufficient to quarter sixteen millions of Europeans living in four large countries. Then there are Montana and North Dakota with their nine hundred thousand people enjoying enough room for Spain and Portugal's twenty-five millions.

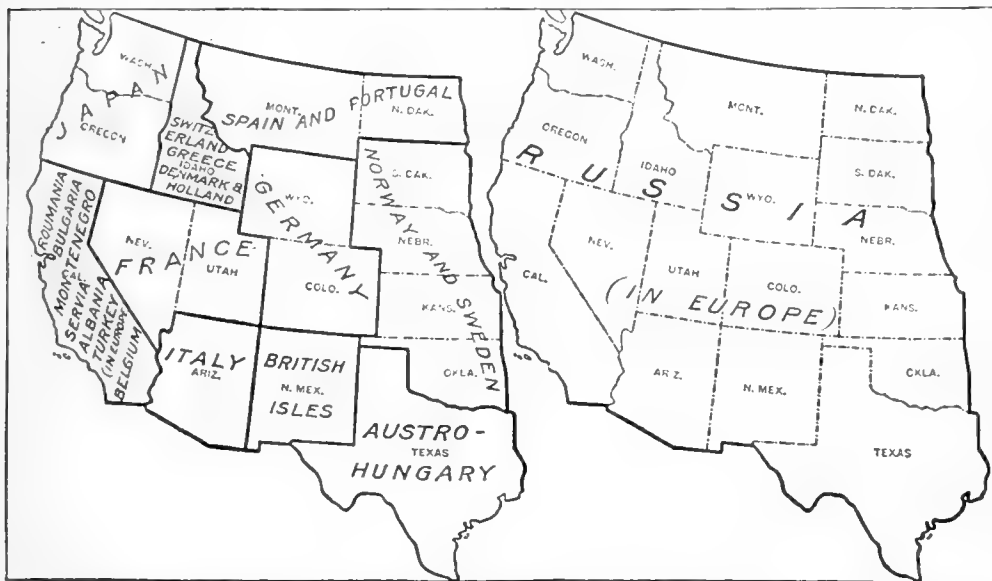

A Map Showing How Snugly the Different European Countries Would Fit into the Western United States, Mighty Russia Occupying As Much Space As All the Other Countries Combined

square miles on Europe's side. At the same time, however, Russia in Europe would spread over the whole western part of our country, crowding it to the doors with its one hundred and eleven millions of people, being the largest of all the European countries.

The State of California has ample quarters for seven European countries, but its population is only a little over two millions, whereas little Roumania alone harbors just about seven million inhabitants.

Austro-Hungary fits rather tightly across the shoulders in Texas, which has a scattered population of nearly four millions, whereas Austro-Hungary has

## New American Porcelain Utensils a Result of the War

ONE of the results of the war was the stoppage of the importation of laboratory porcelain, and this has resulted in the manufacture of laboratory porcelain in this country, which has stood the hydrochloric acid tests equally well with that manufactured by the royal Berlin pottery in Germany, which until now has been regarded as the standard.

The cooking porcelain ware is being produced in ivory, white, brown betty, and olive green, plain and decorated, and for private ward work the pretty decorations and delicacy of the ware make the porcelain highly attractive.

Escaping the Barber's Fingers

HENCEFORTH the barber can keep his fingernails to himself. This fingertip infiltrator, which is nothing more than four rubber fingers leading to a miniature reservoir from which oil and other shampooing liquids can be freely and sanitarily applied to the scalp, does away with all the dangers of infection both to barber and patron.

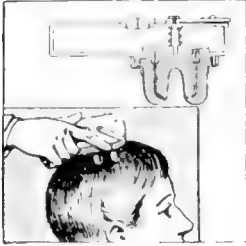

Collapsible Tooth-Brush Case

A RECENT invention is a toilet case which is a combination of a tooth-brush and a container for tooth powder or other dentifrice. The pocket for the dentifrice is a concentric casing having a discharge opening and a perforated cap. The tooth-brush is collapsible and fits snugly into the central portion of the case. It is readily adjusted for use and the case is of convenient size for carrying in the pocket. It locks securely.



Keeping the Baby's Bottle Just Right

THE accompanying illustration shows a water bag so constructed that an infant's nursing bottle can be accommodated within a central opening and its contents kept at the desired temperature. To keep the bottle warm, the bag is filled with hot water, while during the summer season it may be packed with chopped ice or filled with ice water and will prevent the milk from souring.

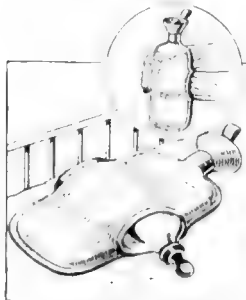

A Pipe with a Cleaning Wick

A NEW tobacco pipe has a removable perforated diaphragm or floor for holding the tobacco and ashes and keeps them away from the bottom of the bowl. A wick extends below the diaphragm into the space where the nicotine and liquid substances collect and leads to the top of the bowl to absorb such substances and prevent their passing into the stem.

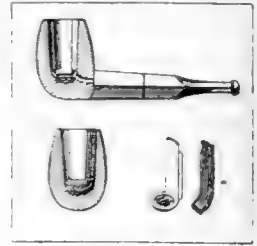

A Detachable Massage Brush

THE invention pictured in the accompanying illustration is a specially constructed massaging device which is designed to be attached to shaving brushes. It is easily detachable and is as readily secured in its operative position when needed. It is provided with a guard which will prevent the possibility of soap and water getting on the massaging fingers and possibly contaminating the surface.

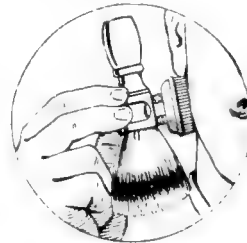

A Mechanical Oyster-Opener

NOT so picturesque, perhaps, as the old seaman who usually poses in illustrations of expert oyster-openers, the mechanical device for the purpose recently invented will nevertheless meet with appreciation. It is a simple machine which comprises a hand lever pivotally mounted, which carries spreading jaws. It can be operated by any one without danger of injury to the hands and does the work quickly.

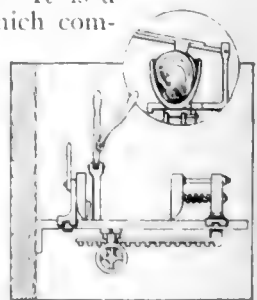



**Holding Asparagus in the Can**

**A**N asparagus can which, when hermetically sealed under vacuum, will collapse inward and thus increase the gripping action of the can on the asparagus, is an improvement on the glass jars and tin containers in use at present. On account of the flat-sided or paneled construction of the can the asparagus is prevented from rotating.

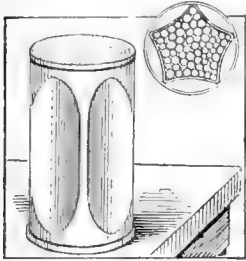

The inside of the can is lacquered to resist the attack of acids on the tin.

**Adding Dignity to Condensed Milk Cans**

**A** CALIFORNIA man has devised a tea-pot as an improved sanitary holder for cans containing liquids such as condensed milk and the like. Discharge and vent openings are arranged in the pot so that the liquid may be conveniently poured. The can is held rigidly in position by sockets. Before placing the can in the pot an outlet hole is punched in the bottom and a vent hole in the top.

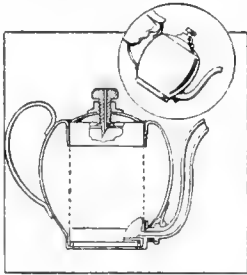

**Reducing Eye-Strain**

**T**O save the human eye from unnecessary strain, to conserve the indirect vision and relieve the muscular spasm, a mechanical concentrator closely resembling a pair of spectacles or goggles has been invented. Instead of lenses the device has two variable iris-diaphragm shutters to control the extent of the openings through which the object is to be viewed and to exclude everything else from the direct line of vision.



**Handle and Cover for Milk Bottles**

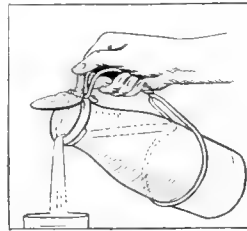

**A** HANDLE and cover for milk bottles and other like containers consists of a device that may be quickly and easily applied to the bottle and as quickly detached.

With it the bottle may be held in any position and the liquid poured. An added feature consists of a cover which is adapted to overlay accurately the bottle top. A rearwardly projecting thumb-piece enables the user to lift the cover at will.

**Putting Exhaust Gases to Work**

**D**IFFERING from all other spark-plugs, this new device relies on the whirling motion of the exhaust gases to remove carbon particles from the electrodes as soon as they are formed. One of the electrodes is shaped like a propeller, lying horizontal. The other electrode is a round rod in the center of the propeller-disk electrode. The gases are exhausted from the spark-plug recess with such force as to whirl them around and between the two electrodes, carrying all carbon particles with them.

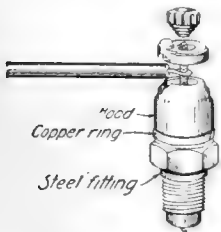

**Stopping Trains Automatically**

**A** COMBINED signaling and stopping device for locomotive engines enables the engineer to receive all signals directly from a lamp in the cab, and in the event of danger ahead throws into operation a lever which automatically closes the throttle valve, stopping the engine. A system of trip levers on the railroad track comes in contact with a lever mounted between the trucks of the locomotive, closing an electric circuit and operating the entire mechanism.

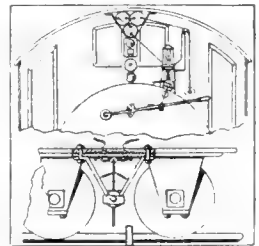

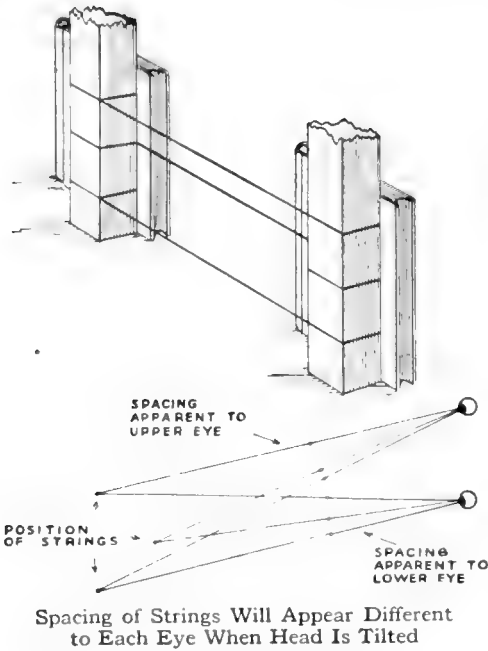

### The Reason Why We Have Two Eyes Spaced Apart

IN the March issue of POPULAR SCIENCE MONTHLY there appeared an article explaining why we have two eyes which showed how the possession of two eyes gives us stereoscopic vision. To this might be added the explanation of another important provision of nature growing out of it, namely, why the eyes are spaced apart on a horizontal line instead of one above the other. If we look at several strings or wires spaced apart and running horizontally across the line of vision as, for example, a group of telephone or telegraph wires stretched horizontally, they will appear to lie in the same plane and all the same distance from the eyes, but upon tilting the head to one side so as to bring the eyes one over the other, the wires will appear in their true relation to each other and to the eyes.

With two eyes our stereoscopic vision is limited to the dimensions running parallel to the plane of the eyes; in other words, the horizontal dimensions of objects and the horizontal spacing between them. As this limitation is unavoidable, the advantage of having the eyes spaced apart in a horizontal plane, so that the stereoscopic effect will reveal the hori-

zontal relation of objects, will be apparent when it is noted that most things in nature, lying in the path of travel, are horizontally spaced apart, such for example as trees, men and beasts walking on the same level and the vertical edges of taller objects. We are seldom called upon to avoid objects by passing over or under them.

To this line of thought might also be added the conclusion that perfect stereoscopic vision in all planes is attained through a third eye positioned above and equidistant from the first two, but this, being of little necessity to our safety, nature has not provided, and its omission can be somewhat compensated for by tilting the head to one side, a thing which we often see people do.

A simple way to verify this is to tie a few strings to the legs of a chair as indicated in the above sketch, with some strings to the front and some to the back of the legs and the points of contact hidden from view. The diagram explains how the spacing of the strings will appear differently to each eye when the head is tilted to bring one eye above the other, giving a stereoscopic effect, but with both eyes on the same level, as for example the upper one, the spacing will appear the same to both.

### Belt Shifter Protects Workmen

FOR preventing some of the serious accidents that are caused by workmen shifting belts rapidly, a Bridgeport company has brought out a belt shifter operating on a new principle.

Tapered rollers project from the end of a pole. The loosened belt is caught between these rollers and forced back on the pulley.

By having the rollers tapered, the belt automatically works toward their bases. This feature prevents the belt flying outwards and possibly entangling the workman, with disastrous results.

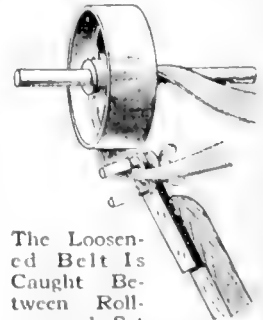

The Loosened Belt Is Caught Between Rollers and Set Back on the Pulley

Spontaneous Combustion

IT is not difficult to understand how combustion may take place without any *apparent* cause. Consider some of the everyday examples of combustion. Coal requires a considerable amount of coaxing before it will ignite, hence the necessity to lay a fire with wood to start the coal and paper to light the wood. A poker at a bright red heat will ignite a gas jet; upon cooling to a dull red heat it will set fire to paper; and after still further cooling will explode gunpowder.

Phosphorus takes fire at a little above 100° F., by no means a high temperature. But the vapour of liquid phosphuretted hydrogen is even more easily inflamed, requiring for its ignition a temperature less than the ordinary temperature of a room. Hence, whenever this substance comes into contact with the air it takes fire at once. This is an example of so-called spontaneous combustion, and only differs from the combustion of a candle in the circumstance that no outside source of heat is required to start the reaction.

Phosphuretted hydrogen can be made by placing small fragments of yellow phosphorus in a flask together with some quicklime and covering with water. Upon boiling the water phosphuretted hydrogen is formed and escapes from a bent glass tube passing through the cork, the other end of the tube dipping below the surface of warm water contained in a dish. As each bubble of gas comes into contact with the air it takes fire and forms white powdery phosphorous pentoxide.—H. T. GRAY.

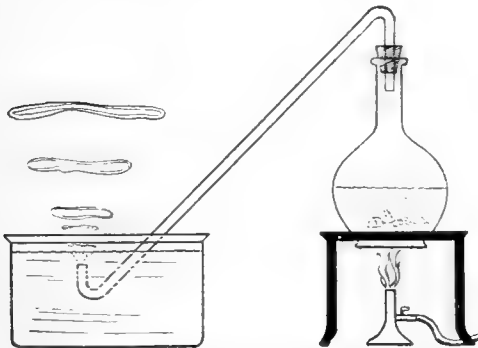

The Phosphorus Powder Produces a Series of Smoke Rings which Expand as They Rise

Fitting Penholders to Crippled Hands

AMONG the many appliances which have been devised to lessen the care of soldiers injured in the war are various kinds of penholders for those with crippled hands. If the thumb and forefinger or the forefinger and middle finger are stiff, or even if all three fingers are not capable of bending, a holder in the form of a loop may be successfully used. This arrangement, in which the control is shifted back into the hand, is shown in Fig. 1.

If the thumb, ring finger and little finger have been amputated, a holder like the one shown in Fig. 2 is of service. The enlarged portion enables the index and middle fingers to grip it securely and also keeps the holder from turning.

When the thumb is good, but all four fingers injured so that only their stubs are left, a triangular block is made that fits the palm of the hand on one side, and has a groove for the thumb on the other side. A firm grasp can be obtained by pressure with the thumb. This device is shown very clearly in Fig. 3.

Casualties are so varied that no standard device can be established. Some are injured in such a way that their hand trembles when writing. A thick holder of wood or cork, which only requires holding but no bending with the fingers, is very successful in this case.

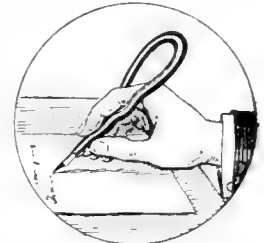

This Loop Arrangement Shifts the Control Back Into the Hand

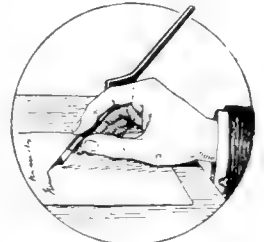

For Use Where Thumb and Two Last Fingers Have Been Amputated

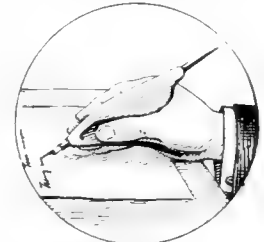

When the Hand of the Injured Trembles While Writing

### A Fascinating Old Sport in a New Dress

AN interesting outdoor game may be evolved from the simple act of tossing a wooden spear at a moving ring. A conveniently located tree, or a cross-arm of scantling may be used to suspend it. The rope is tied to the cleat *C* and passes through several eyes or guides. At the end, the small stick

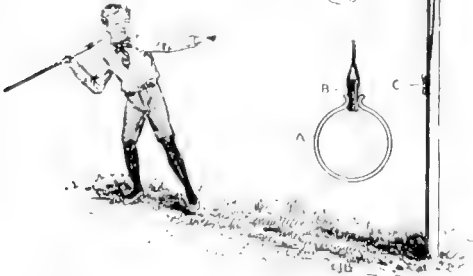

The Ring Is Set Swinging and the Spear Is Tossed Through It From a Distance

*B* is tied. The ring *A* is a piece of spring wire which snaps on to the stick. The spear is a broom-handle or straight pole with one sharp end. The ring is set swinging with a gentle pendulum-like motion and the one about to test his skill endeavors to toss it through. If it touches the ring another trial is allowed, and if it passes through cleanly ten points are scored. As skill increases the throwing distance may be lengthened. After passing through the ring one point is scored for every five feet the spear travels. If it is of this length it will be easy to measure and count the points. The sport is fascinating and admits of much variation in scoring.

### Tracing Magazine Cuts

THE cut is traced on a clean, unused sheet of carbon paper with a sharp pencil. The prints are then made from the carbon sheet; they will be blue lines on a white background. By this method it is possible to pencil additional notes on to the print. The carbon sheets can be used as long as necessary and then renewed by holding them against any hot surface such as an electric globe. This will melt the carbon preparation and soon cover all the lines.

### Measuring Ten Thousandths of an Inch

THE accompanying illustration shows the essential parts of a micrometer designed to indicate on a scale *S* the thickness, in thousandths of a millimeter (one millimeter is about one twenty-fifth of an inch) of any small object placed between two tempered steel blocks, *B*<sub>1</sub> and *B*<sub>2</sub>.

In using the instrument the blocks *B*<sub>1</sub> *B*<sub>2</sub> are first brought together without obstacle, and then the micrometer screw is turned in one direction or the other until *I* stands at zero on *S*. A button is then pressed to turn the lever about the pivot *A* and permit introduction of the body to be measured between *B*<sub>1</sub> *B*<sub>2</sub>. The screw *T* is then rotated as far as necessary to make the spring exert a suitable pressure on the piece between *B*<sub>1</sub> *B*<sub>2</sub>.

Between the block *B*<sub>2</sub> and a fixed block *C* there is stretched a wire between the center point of which and a second

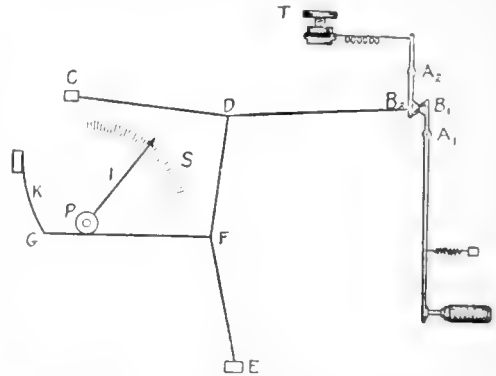

Essential Parts of a Micrometer That Indicates Thickness in Thousandths of a Millimeter on a Finely Balanced Scale

block *E* there is stretched a second wire *DE*. The wire *FG* is attached to the center of *DE* and, after passing round a pulley *P* on the point spindle it (*FG*) is anchored to a plate spring *K*. The latter keeps taut the wires *GF*, *ED* and *B*<sub>2</sub> *C*, hence as *B*<sub>2</sub> moves to the left (when a piece to be measured is introduced between *B*<sub>1</sub> *B*<sub>2</sub> or the zero of the instruments is adjusted), the slack in *B*<sub>2</sub> *C* is taken up by the sag of the wire being increased. Slack thus produced in *DE* is taken up by increased sag at *F*, the spring *K* meanwhile moving to the left to take up slack in *FG*.

# Experimental Electricity

Practical Hints  
for the Amateur



Wireless  
Communication.

## A Microphonic Amplifier

By Arthur Ellison

THE amplification of radio signals is receiving much attention. For this purpose nothing is superior to the audion amplifier, but the price of this apparatus places it beyond the reach of many amateurs.

The microphone amplifier herein described will do remarkable work when properly adjusted, but it *must* be kept free from vibration. The easiest way to do this, and perhaps the best, is to place several layers of felt under the base, or, if possible, to mount it firmly on a solid brick wall. Small, soft rubber feet under the instrument are also of some assistance in cutting out undue vibration.

In the accompanying drawing at Fig. 1 is shown the electromagnetic microphone complete. It consists of two 1,000-ohm telephone receivers mounted on a base in a vertical position.

The receiver shells are drilled and tapped to admit two small machine screws which fasten them to the brass angles. The support

on the left is a plain *L* with a hole in the bottom part to clamp it to the base, but the other *L* is somewhat different in shape and is shown in detail in Fig. 40. As will be readily understood, it is slightly shorter than the first named, and is turned up at the end so the thumb screw will act on it. A slot is cut in the bottom part so that the receiver may be moved forward or backward by operating the thumbscrew, and a spring is arranged to push it back normally.

In the center of each of the diaphragms is mounted a small carbon button. These are only about  $\frac{1}{4}$  in. in diameter and are shown in detail in Fig. 2. A conical hole is drilled in one face and a slot cut with a fine saw on one side. A very thin flexible wire is laid in this slot and solder poured in to hold it there. By twisting the saw while cutting the slot, the slot will be made wider at the bottom, and the solder will hold the wire in place.

The carbon buttons are fastened to the center of the

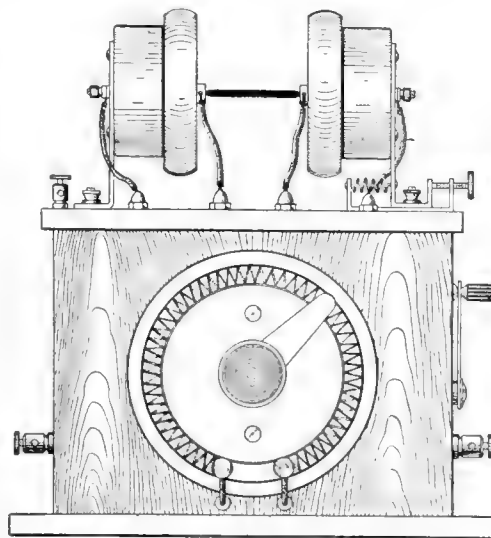

Fig. 1. The Electromagnetic Microphone Complete and Mounted in Position

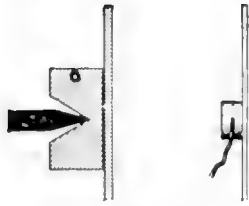

Fig. 2. Carbon Button in Center of Each Diaphragm

diaphragm with shellac. They should be placed in a hot oven to insure the complete evaporation of alcohol in the shellac, and thus hold the carbon firmly to the diaphragm.

The receivers are mounted so their faces will be about 2 ins. apart and connected in series to two binding posts at the left of the base. The thin flexible wires from the carbon buttons are also connected to two binding posts. A neat method of running the connection from these wires through the base makes use of cap nuts as detailed in Fig. 3.

A hard pencil should now be boiled in water till the wood comes off and the lead is left whole. Cut off a piece a trifle longer than the distance between the receivers when the one at the right is adjusted about to the middle of the slot. This lead is carefully sharpened to a point at each end. The point should not be too sharp, for if so it will break off when a little pressure is applied.

The pencil lead is now to be slipped into position by backing out the right hand receiver and placing the ends of the rod in the cavities in the carbon buttons. This completes the microphone.

A good arrangement for controlling the apparatus is shown. A wood box is constructed large enough to contain three standard dry cells. Smaller batteries may be used but they will not last as long. On one side of the box is mounted a four-point switch (Fig. 1) and a small finely adjustable rheostat is mounted on the front.

The batteries and switches are wired as clearly shown in Fig. 5, the binding posts marked  $A^1-A^2$  being on the left side of the box and those  $B^1-B^2$  on the right side. This completes the amplifier, with the exception of the loud talking receiver which is connected to  $B^1, B^2$ .

The loud speaker can be made from an ordinary 75-ohm telephone receiver of the kind that sells for about 40 cents. The fine wire is removed by cutting or unwinding and heavier wire put in its place.

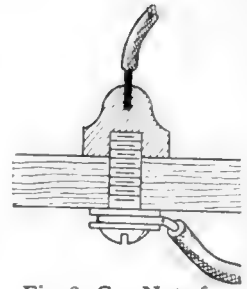

Fig. 3. Cap Nuts for Connecting Wires Through Base

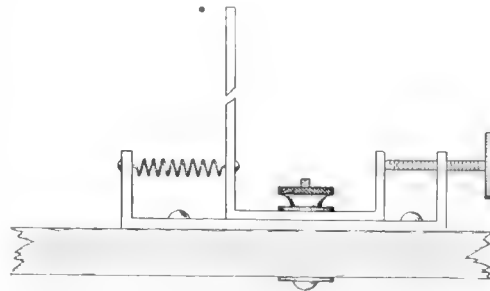

Fig. 4. Detail of Support on Right Hand Side with Thumbscrew Regulator

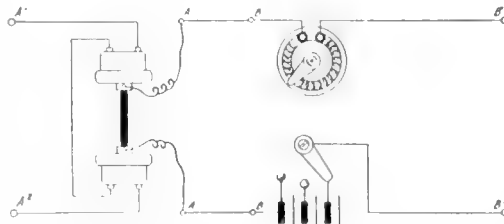

Fig. 5. Method of Connecting Posts of Microphone to Posts of Control

The receiver should then be rewound with about No. 42 wire, to a resistance of approximately 14 ohms.

After rewinding the receiver a short piece of brass tubing 1 in. in diameter and 2 inches long is fastened to the cap of the receiver. Obtain two pieces of brass tubing that will just fit over this tube with a good sliding fit. These pieces are to be 2 ins. and 4 ins. long respectively, and form a variable acoustic resonator.

The binding posts of the receivers on the microphone are connected to the receiving set.

The posts  $A-A$  of the microphone are connected to the posts  $B-B$  of the control box while the loud talker is connected across posts  $B_1-B_2$  (see Fig 5.)

An extra 1,000-ohm receiver should be connected in series with the telephones actuating the microphone, to test the adjustment of the detector. A switch may be arranged to short circuit this additional receiver when it is not required.

# Constructing an Amateur's Aerial

By K. B. Warner

The following contribution won the first prize in the Popular Science Monthly's Radio Prize Article Contest which closed on June 15th. We would call it to the attention of our wireless friends because both in subject matter and in method of presentation it is the kind of radio material that we want to encourage. The article that won the second prize will appear in the October issue. Its subject is "Cures for Trouble in a 200-Meter Wave Outfit."—EDITOR.

THE construction of amateur radio apparatus has been very fully covered in the past few years, but there is a noticeable dearth of data concerning the erection of amateur masts.

Fortunate, indeed, is the amateur who is located so that a mere "2 x 4" on house or barn will furnish a pole of good height. There are many of us not so located, however, and the design and

erection of an eighty-foot pole which the writer put up at a moderate expense are here set forth in hopes that the information will prove of value to amateurs whose range would be greatly increased if their aerials were swung higher.

A sketch of the complete pole is shown in Fig. 2, from which it will be noted that it consists of a timber, *A*, and three sections of pipe, *B*, supported by guy wires at each joint. The timber is provided with an iron collar at the top, through which the pipe is raised; and a small platform 6 feet from the top, from which the work of erection is conducted.

## Details of the Timber

In Figs. 7 and 3 are shown the details of the timber, which is preferably a 6-inch by 6-inch, long enough to stand 28 or 30 feet out of the ground. The length imbedded in the ground depends on the nature of the soil. If good hard ground, the ideal way is to imbed it in concrete. In the writer's case, hard clay was struck at about 4 feet, and a buried platform 3 feet square, as shown in Fig. 1, provided ample bear-

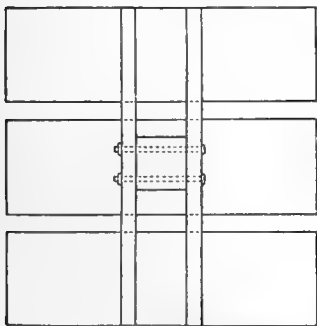
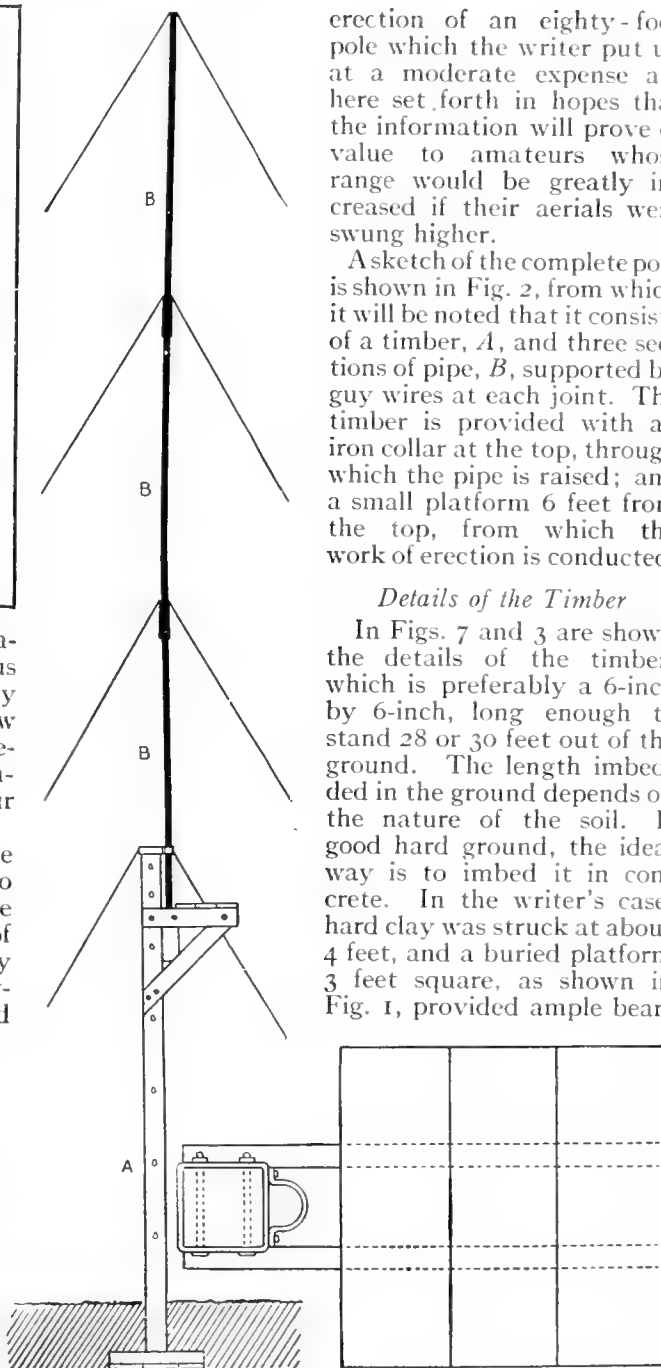

Fig. 1. The Foundation

Fig. 2. The Mast Complete

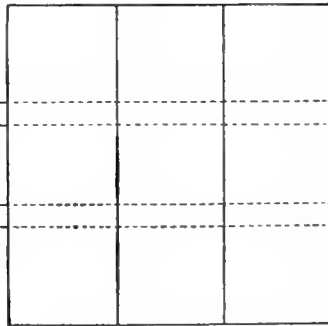
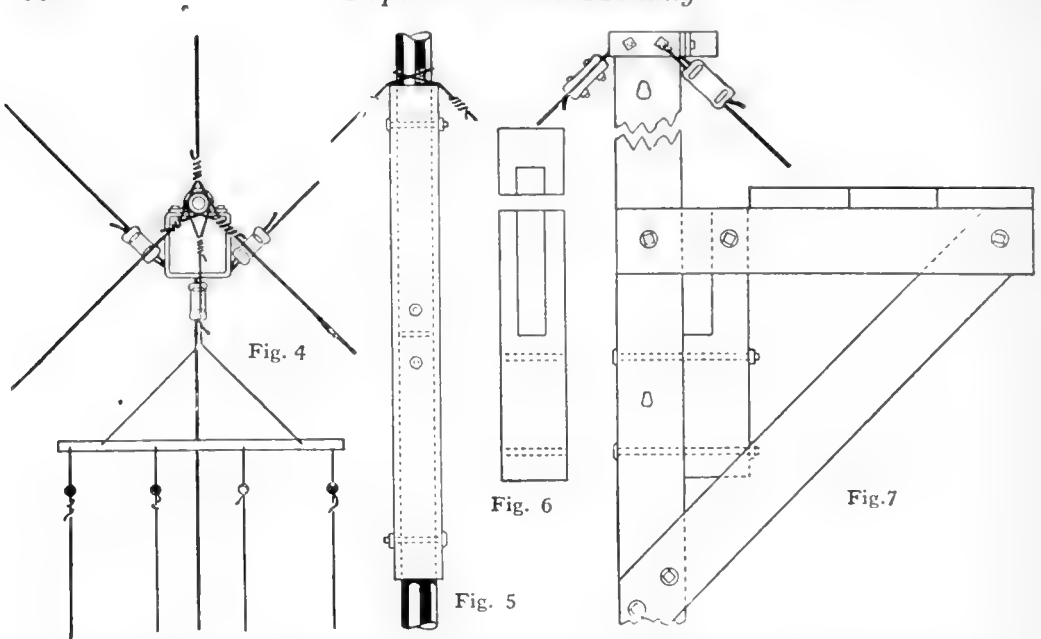

Fig. 3. Top of Platform





Above (Fig. 4), is shown the general guy plan. At left (Fig. 5), is the method of joining pipe sections and attaching upper guys. A good joint is made by butting the ends together and bolting through a sleeve consisting of a 2-foot length of pipe just large enough to slip on. The design as shown is flexible and additional sections of pipe may be added, if desired. At center (Fig. 6), is a view of the base block to hold pipe. At right (Fig. 7) is a side view of wood pole, showing platform and iron loop

ing. Details of the iron collar are shown in Fig 3. This should be made of  $\frac{3}{8}$ -inch by 2-inch strap iron. It has a loop securely riveted on it, made of the same material, of such dimensions as to pass a pipe 2 inches in outside diameter. Fasten this collar securely to the top of the timber with lag screws. It is also to be drilled for securing the guy cables.

The platform on the mast is 2 feet square, supported on two pieces of 2-inch by 6-inch, bolted to the timber; the details are clearly shown in Figs. 2 and 3 of the illustration.

Note that a space 6-inch by 6-inch is provided alongside the timber and between the two supports. Standard pole steps are provided and the wood-work is given two coats of mineral red paint, and the portion to go underground is preferably tarred. The pole is then raised in the excavation beforehand provided. It should be securely guyed by three 7-strand  $\frac{3}{8}$ -inch cables affixed to the iron collar, and trued up by means of turn-buckles.

We are now ready to proceed with the erection of the pipe, which is composed of 20-foot lengths of standard 1  $\frac{1}{4}$ -inch galvanized well-pipe. Black pipe of the same size, if given two coats of aluminum paint, will be found very satisfactory for the purpose.

Do not use pipe unions between joints, as they are not strong enough. A good joint may be made, as in Fig. 5, by butting the ends together and bolting through a sleeve consisting of a 2-foot length of pipe just large enough to slip on.

### *Erecting the Pipe*

Erection is accomplished as follows: The top piece of pipe is inserted through the 6 by 6 opening in the platform supports, and through the loop in the iron collar, and temporarily suspended so the top is just a few inches above the collar.

Aerial pulley and rope are fastened with an eye-bolt through the end of the pipe, and the top set of three galvanized No. 12 gage iron wires secured around

the pipe above the bolt. From his position on the platform, the erector can easily raise the pipe hand over hand until it is high enough to couple on to the second section in the manner shown in Fig. 5. The two coupled sections are then raised until the coupling is just above the collar, where they are temporarily suspended by a hook inserted in the bottom pipe, and the second set of three guy-wires attached.

*Handling the Guy-Wires*

From this point on it will be necessary to enlist the services of neighbors to hold and pay out guy-wires. The two sections are raised in the same manner high enough to couple on the third section. After this it will be necessary to resort to block and tackle. A good way to use this is shown in Fig. 8, in which it should be noted that the temporary arm, made of two 5-foot pieces of 2-inch by 4-inch, straddles the pipe and is securely guyed in its position at the rear.

platform supports and the timber as indicated. A rope hitch around the pipe serves to lower it gradually into the hole, after which the guy-wires are trued up and the mast is complete.

In Fig. 4 is shown how the guys may be spread in six directions. It will be found very desirable to break the guy-wires up into short lengths to prevent absorption of energy. Ordinary porcelain knobs are quite satisfactory for this purpose. Buried logs make excellent guy anchors; they should be set well out from the base of the pole.

*The Mast Will Resist Storms*

This makes a strong, serviceable, neat-appearing mast. The writer has one, erected over a year ago. Standard couplings instead of pipe sleeves are used between the joints, which support a heavy 200-meter aerial made of No. 9 solid copper wires. It has successfully withstood several 60-mile squalls, besides some exceptionally heavy sleet storms.

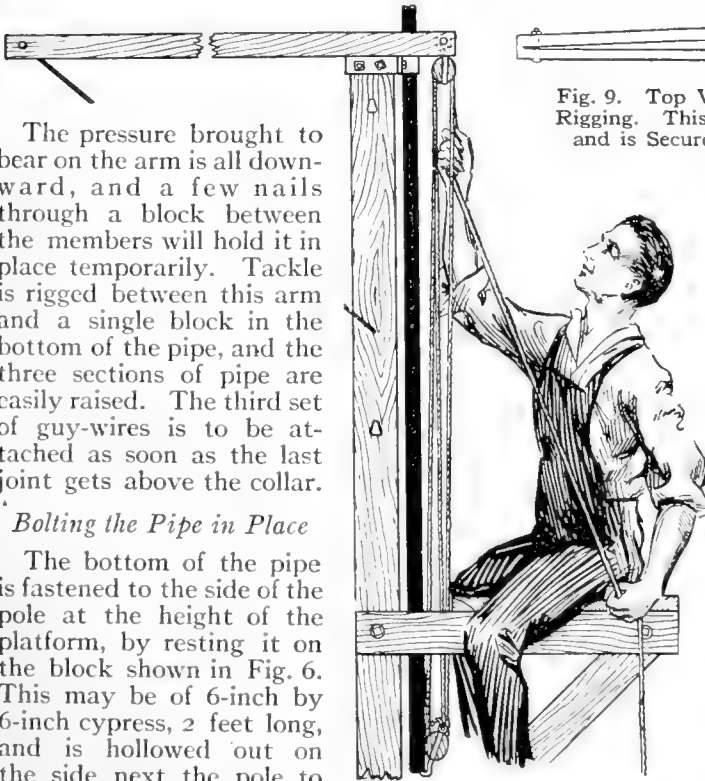

Fig. 9. Top View of Temporary Arm Rigging. This Arm Straddles the Pipe and is Securely Guyed at the Rear

The pressure brought to bear on the arm is all downward, and a few nails through a block between the members will hold it in place temporarily. Tackle is rigged between this arm and a single block in the bottom of the pipe, and the three sections of pipe are easily raised. The third set of guy-wires is to be attached as soon as the last joint gets above the collar.

*Bolting the Pipe in Place*

The bottom of the pipe is fastened to the side of the pole at the height of the platform, by resting it on the block shown in Fig. 6. This may be of 6-inch by 6-inch cypress, 2 feet long, and is hollowed out on the side next the pole to receive the pipe as shown. It is securely bolted to the

The design herein set forth is of course flexible, and the builder can easily add an additional 20-foot section of pipe if desired.

The round pipe offers much less resistance to the wind than wood timbers of equal strength, and as it is well insulated from the ground, there is little or no loss from this cause.

It would be well to provide a grounding switch for lightning protection on the side of the timber near the ground, connected with the pipe by a heavy copper wire, but this is not absolutely necessary.

Fig. 8. Showing Rigging of Temporary Arm for Final Lift

### A Convenient Arrangement for Turning on the Hall Light

WHILE nearly all new buildings are wired so that the hall light can be turned on and off from either floor, the older buildings do not have this convenience. The cost of installing cross switches is considerable, but an arrangement that will serve the purpose can be installed at slight expense.

Get a chain socket for the lamp. Tie a cord to the chain, run it through two eyelets as shown in the sketch, and fasten the other end of the cord to the newel post at the head of the stairs. The

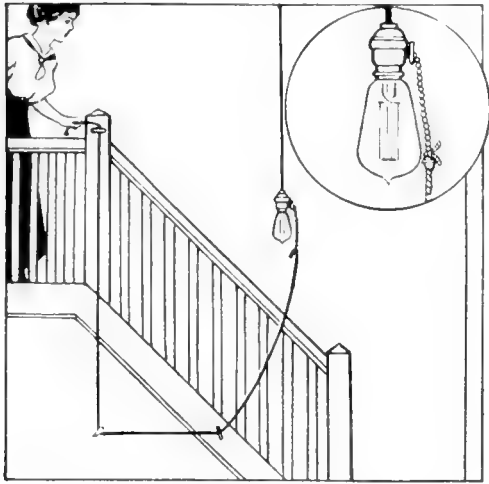

Where There Are No Cross Switches This Method of Control Will Answer

entire cost will be fifty cents for the chain socket. If you do not care to put screw eyes in the woodwork, loops made from heavy wire can be tied to the banister rails. Any other method of conveying the cord to the newel post might prove equally as satisfactory and inconspicuous.—E. F. AYRES.

### Guying the Mast

IN putting up an aerial, one very essential feature, seldom mentioned by the authors of experimental wireless books, is the necessity for a strong brace at the top of the mast. It is a good plan in erecting a mast, to adjust a guy wire so that it will pull back directly against the strain of the aerial. Otherwise the top of the pole will lean inward and perhaps break off.

### Wiring the Ford Automobile for Magneto and Battery

WHILE the Ford owner has been impressed by the simplicity and cheapness of his magneto lighting system, he has found many serious faults. If he slows down for bad roads, the voltage drops and his lights become wretchedly dim. If he speeds on a bit of smooth road, the voltage rises and burns out his bulbs. It is then he longs for a good storage battery. However, he does not like to give up the use of the magneto. Its light is fine for city driving and ordinary travel. If he only could snap on the battery for emergencies! How can he wire his car to use both?

The difficulty is due to the fact that his magneto furnishes a twelve-volt current and his battery but six. With magneto, two six-volt headlights must be wired in series to prevent burning out. If he uses the battery, the wiring must be changed to parallel or the lamps will not receive pressure enough to light them.

He can easily solve the problem by mounting a three-pole two-throw switch on left of dash within easy reach and making connections as shown in the accompanying diagram.

When the handle is thrown up, three knife blades close the gaps *b* and connect the battery parallel with the headlights. When the handle is down, the two outer blades close the gaps *m* and connect the magneto *M* in series. *S* represents a couple of snap switches. These should both be snapped on whenever light is needed and the three-pole switch will instantly change from one current to the other—S. D. BATES.

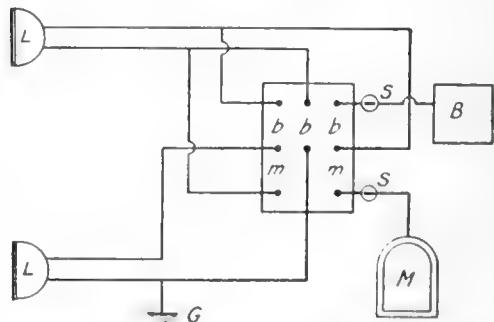

Diagram of Connection of Three-Pole Two-Throw Switch on Ford

**A Simple Way to Construct a Ten-Ampere Shunt**

**A** 10-AMPERE shunt which can be used in connection with an ammeter, either of the home-made variety or of a standard type, can be constructed with little difficulty. When used in connection with the standard ammeter it is assumed that the meter is calibrated for a much lower reading than that which is desired. Through the simple addition of the shunt, the meter may be made to measure a current several times as large as that handled without the shunt.

The materials necessary are as follows: strip of German silver, brass blocks, block of wood, screws for am. leads, screws to hold the line wires tight, leads to fasten brass blocks to the block of wood, and a hole for line wire.

First, saw two pieces of brass and file them smooth, so that their dimensions are 1 in. by 3/4 in. by 3/4 in. Drill holes, as shown, with a No. 25 drill, making them of suitable size for screws to hold the brass block to the base. Thread the ones for wire terminals with a 10-in. by 24-in. tap.

Secure a piece of German silver, 12 mil. thick (.012 in.) and 2 3/8 ins. long, and calculate its width by the following method. In calculating the width, the length of the German silver strip is 2 ins. because the 3/8 in. goes into the brass block, 3/16 in. in each one. The ammeter reads 50 millivolts on full scale deflection.

1 millivolt = .001 volt. 50 millivolts = .05 volt; current 10 amp.

$$E = .05$$

$$R = \frac{E}{I} = \frac{.05}{10} = .005 \text{ ohms resistance of the German silver.}$$

$$R = \frac{Kl}{A} \quad A = \frac{Kl}{R}$$

A R where K is the resistivity of German silver, l is the length in ft., R the resistance, and A the area. The resistivity of German silver is 20 times that of copper. 10.4 = resistivity of copper. 1 = 2 ins. = .167 ft. so 20 x 10.4 = 208 resistivity of German silver.

$$A = \frac{208 \times .167}{.005} = 7214.5 \text{ cu. mils.}$$

$$A = 7214.5 \times .7834 = 5666.36 \text{ sq. mils.}$$

$$5666.36$$

$$A = \frac{5666.36}{1,000,000} = .00566 \text{ in.}$$

$$\text{Thickness} = .012 \text{ in.}$$

$$\text{So width} = \frac{A}{\text{TH}} = \frac{.00566}{.012} = .471 \text{ in.}$$

Cut a groove in each brass block 3/16 in. deep and 1/4 in. up from the bottom, and solder one end of the German silver strip in each block, as shown in the diagrams. When the strip

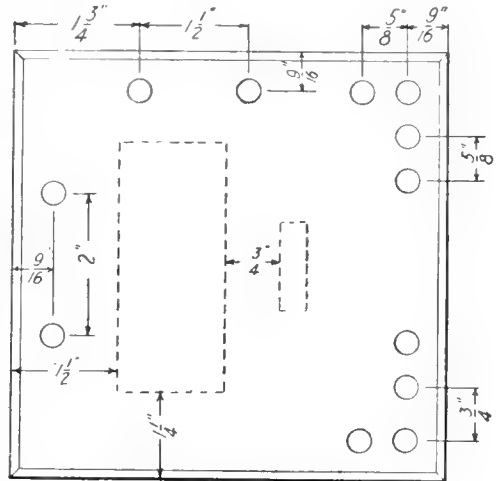

**A Diagram Showing Dimensions and Component Parts of Shunt**

is firmly fastened, file off the stray solder which may have remained on the brass blocks. Cut a block of wood 6 3/4 ins. by 3 1/4 ins. by 1 1/8 ins., plane it until smooth, and then sandpaper and shellac it. When it is dry, screw the brass blocks on it in the right place, according to the dimensions given in the accompanying diagrams.

After it is securely fastened, connect two ammeters with two 10-amp. shunts, one a standard and the other the one described above, in series with a D. C. source. Pass 10 amperes through the meter with the standard shunt; and note the reading on the other ammeter. In most cases it will read a little low, because the calculations for the width of the German silver strip may be a little inaccurate. File the shunt until both ammeters read the same.

### Controlling Temperature and Humidity at the Same Time

**A**N APPARATUS for automatically controlling the temperature and humidity of one or more spaces or rooms consists of a thermostat for determining the temperature and a hygrometer for determining the humidity, both instruments being electrically connected with a regulating mechanism. The thermostat consists of an ordinary mercurial thermometer having metallic contacts fused in its tube at predetermined points to form contact with the mercury column.

One of the contact points is at the maximum heat-point, fixed at seventy degrees, and the other is at the minimum heat-point, which is fixed at sixty-five degrees.

When the mercury touches either of these contact points a circuit is closed and the temperature of the room is regulated accordingly. The principle involved is of the simplest and its adoption ought to do much toward helping the weather man please a limited public.

The hygrometer consists of a flat helical, or spiral, body composed of a highly hygroscopic substance which assumes various shapes and more or less expands according to the amount of humidity absorbed. The helical body winds tighter or unwinds as the humidity fluctuates, and registers its movements by a dial swinging over an index. When the dial touches contact points on the index an electric circuit is thereby completed which either increases or diminishes the humidity.

In practice both of these controlling devices are connected to admit heated or cooled air to the room or space. With a rising temperature and increasing humidity circuits are closed which actuate other apparatus which in turn operate to admit cooler and drier air.

### Electric Substitute for the Old-Fashioned Latchkey

**A** CONVENIENT and efficient device for unlocking any door fitted with a spring lock is shown in the accompanying sketch. A fairly stiff spring *A*, is connected by a flexible wire cord to the knob *B*. The cord is also fastened to a lever *C*, which is pivoted at *D* and is

released by a magnetic trigger *E*, made from the armature and magnet of an old electric bell.

When the circuit is completed by means of a secret contact device outside the door, the magnet *F* pulls down the armature which releases the trigger and allows the spring to open the lock. If there are metal numbers on the outside of the

door they may be used for the secret contact, if desired. If there are no numbers on the door, a small contact board may be constructed by driving about 10 brass-headed tacks into a thin piece of wood to make connections. Then however dark the night there will be no trouble opening the door.—WILBUR SEIPEL.

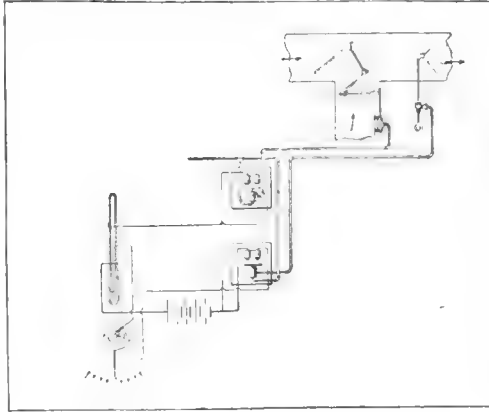

Thermostat and Hygrometer Electrically Connected with Regulating System

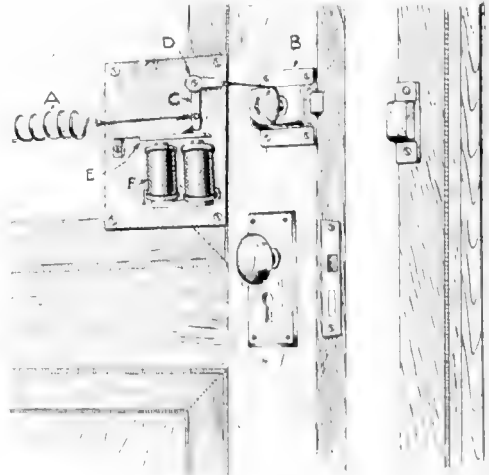

Essentials in the Arrangement for Unlocking Door Without a Key

A New Tuner Arrangement

**I**N building an inductive coupler, the problem of reducing the usual number of taps and switch points without losing flexibility of adjustment was solved as outlined below.

The instrument was designed to be a cabinet set. Since the space available within the case was rather limited to use, a sliding secondary coil was impractical. Hence the "static" type was adopted. Primary and secondary coils were wound on tubes of the same diameter and placed at right angles to each other to prevent induction between them. Both cylinders are 8 ins. long and 3½ ins. in diameter. The primary is wound with No. 26 enameled wire, tapped at every 22nd turn, 18 taps in all. The secondary is wound with No. 30 enameled wire, tapped at every 35th turn, 18 taps in all.

To permit of sharp tuning in the primary circuit, a small variometer was constructed. The maximum inductance of this is slightly more than a one-point variation on the primary switch (22 turns). Hence with the variometer connected in series as shown, even sharper tuning can be accomplished than with a tuner tapped to single turns. A variable condenser of .0005 mf. is shunted across the secondary for the close tuning of that circuit, and a second variable condenser of .001 mf. is connected between the primary and secondary coils, which latter controls the coupling between the two. The entire set is wired according to the diagram. Comparative tests with other instruments have proven that the hook-up here described brings in strong signals and permits of sharp tuning.—EDWIN L. POWELL.

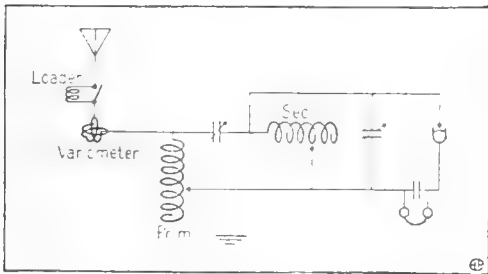
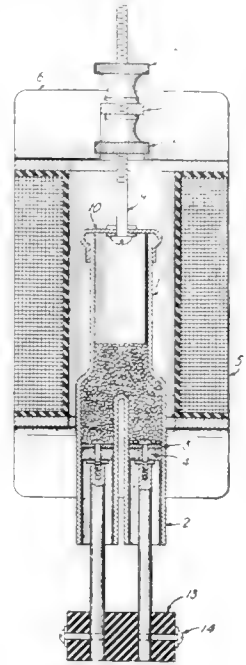

Diagram of the Wiring in the Construction of a Tuner Cabinet Set

Lepel Improves His System

**A**N important 1916 patent is number 1,168,837 issued to E. von Lepel for a method of producing electrical oscillations. The drawing is a reproduction of one of the eight circuit diagrams shown, and is typical of the invention. A direct current generator 2 supplies power to the condenser 1 through impedances 7 7 and resistances 6 6. The discharge of the condenser 1 takes place through the primary of oscillation transformer 5 and across the parallel-plate quenched spark-gaps shown at 12.



One of the Eight Circuit Diagrams of the Lepel Patent

The antenna and ground are connected to the terminals of the secondary of transformer 5.

If the constants of the circuit are properly chosen, according to the theory which is explained in detail in the patent, the combination of the quenching spark-gaps with the "inertia coils" will result in an arcless discharge in the oscillation circuit, and the production of practically perfect sustained oscillations in the antenna circuit. When it is desired to telegraph by radio according to the tone method, an auxiliary tuned low-frequency circuit 15 is inserted as shown, its natural frequency being that of the note which it is desired to produce at the receiver. The effect of this added circuit is to reduce the amount of outgoing radiation periodically.

By combining several values of inductance and capacity in the tone-controlling circuit, and connecting them with a group of keys, it has been found possible to produce tones of the musical scale and to transmit musical airs by wireless over a long distance.

### Making an Induction Coil

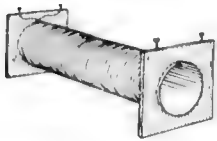

Fig. I

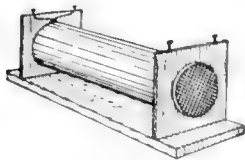

Fig. II

Induction Coil  
Large Enough for  
a Small Wireless

**T**HE laboratory of the electrical experimenter is incomplete without an induction coil, and in commercial work this device probably serves more purposes than any other piece of electrical apparatus. A coil large enough for a small wireless, and one which will make a spark big enough to ignite gunpowder some

distance from the switch, can be made by any amateur, with little expense.

Secure a tube of cardboard or hard rubber, 1 ft. long, with an outside diameter of 1 in. Cut two pine blocks 1 in. thick and 6 ins. square. Bore a 1 in. hole in the end of each block and slip the ends of the tube into these holes, tacking it to the wood from the inside. Apply several coats of shellac to the whole arrangement, allowing each coat to dry before adding the next. Binding posts or wooden screws are screwed into the upper edges of the blocks, as shown in the diagram.

The coil should next be wound. If a lathe is available, fasten the tube and blocks between centers, and the winding will be an easy matter; if not, it may be wound by hand, though the process is slow. For the primary coil use No. 20 double cotton-covered copper wire. Fasten one end to a binding post, and wind a layer evenly on the tube. Coat with shellac; add a layer of thin paper and shellac that. Repeat this process until four layers are wound, fastening the end of wire to the other binding post on the same block with the end started with. Wind on several layers of paper and coat liberally with shellac. This keeps out moisture, which is fatal to the proper working of the coil.

Wind the secondary coil with about 2 lbs. of No. 36 insulated copper wire. Proceed as with the primary coil, but use the binding posts at the opposite end of the tube. Shellac and paper are

applied as before; after the last layer of wire, add an extra coating of each.

The coil may be mounted on a wooden base, 14 ins. by 6 ins. by 1 in. Give it several coats of shellac. Kiln-dried wood is best for the whole apparatus, if obtainable.—P. J. McCLUTE.

### Magnet Winder

**I**N winding a magnet coil it is often a tedious job to get the layers smooth, especially if the wire is small. In the accompanying sketch is shown a device which overcomes this difficulty.

It consists of an ordinary hand-drill which is firmly held in the bench-vice.

The magnet spool is easily fastened in the chuck by using a long screw of the same thread as that intended for the magnet. By cutting off the head it may be held in the chuck as a regular magnet winder.—E. C. MEILLORET.

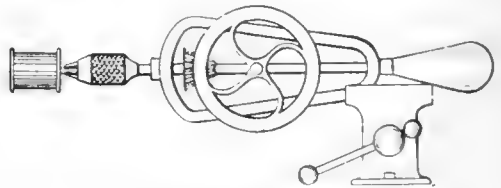

Device for Facilitating the Smooth Winding of a Magnet Coil of Fine Wire

### Utilizing Broken Marble Pieces

**P**IECES of broken marble can often be purchased from the second-hand stores for a few cents and then cut and worked into excellent bases for supporting wireless instruments. If such bases were purchased from the marble worker they would cost a great deal more.

The pieces of marble may be sawed to shape by hand, using a strip of sheet-iron as a saw and common river sand as the abrasive. To polish the edges use sand and water upon a piece of scrap marble or glass, and rub the piece to be polished over the abrasive until the desired finish is produced.

### Dry Cells and Their Voltage

**T**HE ordinary dry cell should show a voltage of nearly one and a half and an instantaneous test-current of over fifteen amperes, if it is to be depended upon for running an induction coil or similar instrument.



### How to Rid Your Yard of Cats

CONSIDERABLE amusement may be derived from a device which effectually rids any backyard of stray cats.

There are many who may find it to be somewhat of a comfort as well as an amusement, if the number of these feline nocturnal musicians in the neighborhood is larger than is appreciated.

Nail two copper wires along the top of the fence, 1 in. apart, care being taken that they do not touch. Fasten them to insulated wires leading to the secondary of a spark-coil in the house. Connect the coil in series with six or more batteries and a switch.

When the cats appear on the fence, close the switch. The effect of the shock varies with the nature of the cat,

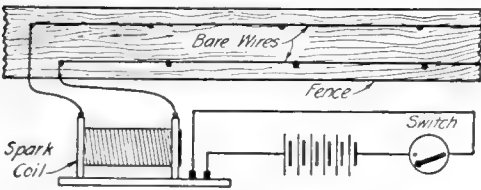

Arrangement of Wires Along Fence Showing One Battery and Switch

but in every case the cat will move on. A similar arrangement can be attached to a garbage can, which must stand on a dry board. The wire leading to the can is insulated, and the other should be grounded.—ALEXANDER BOLLERER.

### To Stop the Milk Thief

NO one need be deprived of cream for his coffee by some hungry individual who steals his milk bottle from the porch. The device shown here will effectively prevent any such occurrence.

The apparatus is connected with a switch, bell and battery, and when any one attempts to lift the milk bottle, the bell is rung.

The bottle stands upon a metal disk to the center of which is joined a heavy wire, which runs through the flooring where it terminates in a loop. Through this loop runs a flat spring, which is held away from a large screw by the weight of the bottle. When the bottle is lifted the spring raises the disk and

touches the large screw, forming a contact and giving the alarm.

By studying the diagram it will be noticed that one wire is soldered to a support on which is hinged a small rod insulated on one end and contacting with a small L-shaped bar, through which the current runs to the large screw. This part of the apparatus is an automatic switch.

When it is desired to set the switch, the disk on which the bottle should stand is pulled up, and the lower end of the wire loop bears against the small rod which breaks the circuit. The switch is turned on in the house. When the bottle is set upon the disk the contact is broken at the large screw, and the small rod is forced into its original position by making a contact with the L-shaped bar.

If the bottle is removed before the house switch is opened, the spring rises with the disk and makes a contact, but owing to the play in the loop, does not break the circuit through the rod. The circuit can only be broken by pulling the disk up farther than the spring can force it.

With this arrangement, it is absolutely impossible for any one to steal the bottle without your knowledge. Of course, the milkman must be instructed to be sure to set the bottle upon the disk each day.—ED. GETTINS.

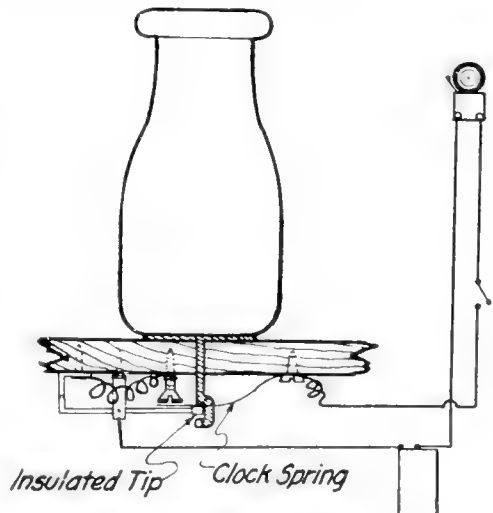

Mechanism of the Automatic Switch for Catching the Milk Thief

### A New Variable Condenser

**M**OST experimenters find difficulty in constructing variable condensers such as sold on the market, in which the effective area of the plates varies. In the condenser here described, the distance between the plates is varied.

The instrument is mounted on a circular base  $5\frac{1}{2}$  ins. in diameter; *A* and *B* are brass disks  $2\frac{1}{2}$  ins. in diameter; *B* is soldered to screw *E* and fastened to the base as in the drawing. A wire from *E* connects *B* with a binding-post; *C* and *C'* are rubber pillars upon which the brass rod *D* is mounted. The rod is threaded so that *A* will remain parallel to *B*. Between the two disks, insert a sheet of mica *F*, about .005 of an in. in thickness. The capacity is varied by turning the knob *G*. The maximum capacity will be .00176 mfd. with the best grade of mica.—MATT JAROSZ.

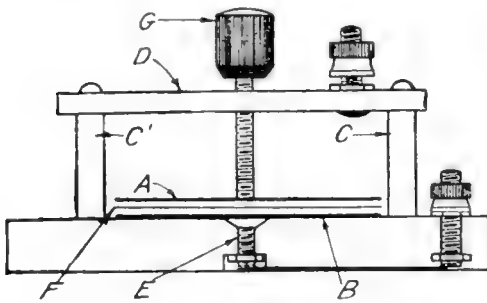

The Distance Between the Plates in This Condenser is Variable

### The Quenched Gap

**A**MONG other things the close coupling, and consequently the increased efficiency of radiation, possible with this type of gap, make its use very desirable. Unfortunately it does not prove very satisfactory for amateur use, as the 60-cycle current usually supplied on lighting circuits to which amateurs have access, used with ordinary transformers, often gives a very mushy note to the spark. This renders it unsuitable for working through static or other interference. The difficulty may be avoided to some extent by using the quenched gap in series with a rotary gap, thus raising and regulating the frequency of the discharges. The

quenched gap can also be used with a spark-coil, but the resulting note is not always very satisfactory.

With regard to the adjustment of the gap, it should be noted that the plates must be kept clean and air-tight.

### A Kickback Preventer

**T**HE apparatus described herein is one of the simplest forms of kickback preventer, and will take care of all high frequency surges on the primary leads of a wireless transformer.

It consists of three plates of aluminum, immersed in a saturated solution of sodium phosphate or bi-carbonate of soda.

In the drawing is shown a method for suspending the plates in a common quart mason-jar. The instrument is to be connected to the apparatus as shown in the wiring diagram.

Its action is not unlike that of a condenser, due to the thin insulating film that forms on the plates when current tries to pass from one plate to the other. Any extremely high voltage surges will puncture this film and thus be discharged to earth. The fuses will prevent the flow

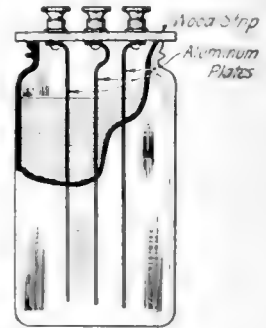

Method of Suspending the Plates in a Quart Mason Jar

of too much live current. The film is replaced automatically when the voltage is reduced. It may be noted that two small aluminum plates immersed in the above solution placed in a test tube, will form a good renewing condenser of fairly high capacity.—ROBERT KENNEDY.

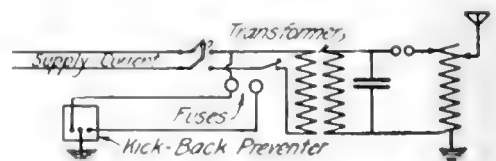

Diagram of the Wiring by Which the Instruments are Connected

# How to Become a Wireless Operator

## I.—Why Wireless is Interesting

By T. M. Lewis

**N**OBODY knows just how many amateur wireless operators and experimenters there are in the United States; the total number has been estimated as somewhere between twenty thousand and fifty thousand. Nearly ten thousand licenses for amateur stations have been issued by the Department of Commerce. Each one of these licenses is for an amateur station which contains both a transmitter and a receiver. No license is required for stations equipped for receiving only, and it is believed that there are many more of these than of the sending stations.

Why have so many American boys and young men taken up this subject? What is there about it that interests them, and induces them to spend their time and money in buying, building and using wireless instruments? The answer to these questions is simply that wireless or radio telegraphy represents one of the latest developments of electrical science, and that it offers both amusement and profit to whoever cares to work upon its problems.

Whether you wish merely to make a pastime of wireless experimenting or desire to study radio telegraphy with the intention of making some part of it your profession, you will find time spent on it well worth your efforts.

In the first instance you will be able to receive messages through the ether from stations many miles away, getting press reports of important news items, and the results of races and ball games and so forth, before they are published in local papers. In the second case, you will be

able to train yourself as a radio operator or installation engineer, or possibly you will make new inventions or discoveries of commercial value. Either way you will constantly be learning more and more about electricity and its applications, as well as getting a better knowledge of many important physical principles which may be used in almost any kind of work.

In addition to all this, there lies before you the fascination of sitting at your receiving instruments and listening to wireless messages from stations located all about you. Soon after you begin it is possible to hear from distances of several hundred miles, and after you have gained a thorough knowledge of your instruments and their possibilities it becomes feasible to listen to the tremendously powerful transmitters even so far away as Germany and the Hawaiian Islands.

### *Elementary Principles*

This article is the first of a series which will describe a number of really practical and useful instruments for use in radio telegraphy, both for sending and for receiving. The ways to make and use these various pieces of apparatus will be discussed in detail, but it is not proposed to go into the theory of wireless telegraphy at

all. By going to your library you will be able to find books and periodicals which describe the principles of ether-waves and their uses in wireless; some of the books you will wish to buy and have in your own workshop for ready reference. Among the most interesting

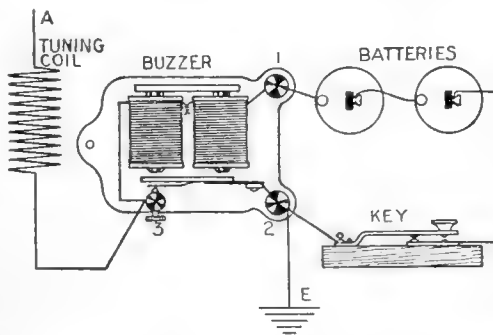

Fig. 1. A Complete Wireless Set Which Is Capable of Sending Messages

and valuable of these are the following, which are named in the approximate order of their complexity:

"The Elementary Principles of Wireless Telegraphy," by R. D. Bangay.

"Experimental Wireless Stations," by P. E. Edelman.

"Wireless Telegraphy," by A. B. Rolfe-Martin.

"Textbook on Wireless Telegraphy," by Rupert Stanley.

"Wireless Telegraphy," by W. H. Marchant.

"Elementary Manual of Radio Telegraphy," by J. A. Fleming.

"A Handbook of Wireless Telegraphy," by J. E. S. Murray.

"Wireless Telegraphy," by J. Zenneck, translated by A. E. Seelig.

The above list should be useful as a guide in hunting for technical information about radio telegraphy. There are many other books on the subject, a large number of which are excellent. Those named, however, include one or more of each type from the most elementary to the most advanced.

### A Simple Transmitter

In beginning experiments on wireless telegraphy it is best to take up first the least complicated arrangements, which are suitable for very short distances, and then to work along gradually from these to the more important instruments. This first article, therefore, will describe the use of a complete wireless set which is capable of demonstrating the principles involved. By its use you should be able to send messages a distance of a few hundred feet, from one part of the house to another; by using long aerial or antenna wires, upward of a quarter of a mile may be covered.

The sending station involves nothing more than a simple buzzer, a telegraph key, a tuning coil and a few cells of dry battery. These are to be connected

together as shown in Fig. 1; a good kind of wire to use is No. 18 annunciator, since this has a strong waxed double cotton covering which is easily removed. The buzzer can best be purchased from any electrical supply store for about forty cents; the key may be bought, or simply improvised by cutting and bending some thin strips of brass as shown in

Fig. 2; the dry cells will cost from twenty to thirty cents each.

The tuning coil may easily be built by winding about fifty turns of annunciator wire on a cardboard tube approximately three inches in diameter. The ends may be fastened and at the same time made available for convenient connection by attaching them to

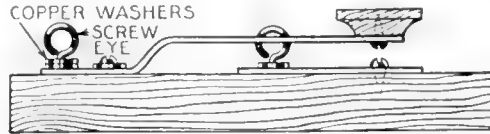
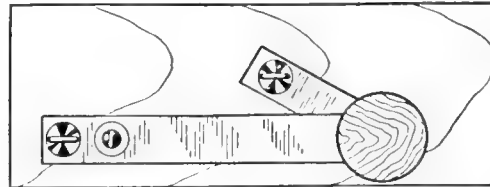

Fig. 2. The Construction of the Buzzer for Sending Apparatus



A Key Made by Cutting and Beading Some Thin Strips of Brass

binding posts let into the tube at the top and bottom. There is no need of building this tuning coil of any specific size. The diameter may be anything from two to four inches, and the number of turns from thirty to seventy. It is only necessary that two identical coils be built, one for the sender of Fig. 1, and the other for the receiver of Fig. 4.

In setting up the sender it will be found that one end of the tuning coil must be attached to the contact post of the buzzer, which is marked 3 in Fig. 1; this can be done by removing the cover of the buzzer and wrapping a bare copper wire firmly about the post. Care must be used to prevent the contact wire from touching the metal base, however, or the operation of the buzzer will be stopped. Binding post 2 is to be connected with "earth" as indicated at *E* in the diagram. The earth connection is easily made by running a wire to a water pipe or steam radiator and wrapping the bare end tightly about a scraped or plated portion of the pipe. The upper end of the tuning coil is to be led to the aerial or antenna wire, at *A*. This antenna may be of any convenient size,

but the larger it is the farther you will be able to signal. For transmitting from room to room within the house, it will be sufficient to string some twenty feet of wire around the picture moulding near the ceiling.

If you have set up the apparatus properly the buzzer will hum strongly as long as you hold down the sending key and thus close the battery circuit. By pressing the key for short and long intervals you can produce short and long buzzes which correspond to dots and dashes in the Morse telegraph code; in this way messages can be spelled out letter by letter.

### A Microphone Receiver

For the receiving station you will need to make another ground connection by fastening a wire to the steam or water pipes, and then the next thing is to build a second antenna or aerial wire system exactly like that at the sender. The second tuning coil, an old dry cell (preferably one which has become very weak), a telephone receiver and the microphone detector are to be connected together as shown in Fig. 4. Any telephone receiver will do; you can buy a 70-ohm watchcase instrument from an electrical store for about 75 cents, but if you intend to continue with wireless experimenting it will pay you to invest several dollars in a pair of telephones of high sensitiveness. These will not only make it possible to receive messages from longer distances, but because of the headband with which they are fitted you will be relieved of the nuisance of holding the receiver to your ear and will have both hands free for manipulation of your apparatus.

The microphone detector is to be made as shown in Fig. 3, which indicates how two large double binding posts are to be mounted upon a hard rubber or wooden base. Two sharp sewing needles

are inserted into the upper holes of the binding posts, and between their points is lightly supported a short length of graphite from a soft pencil. The piece of graphite should be about one-half inch long, and should have its ends partially hollowed out so that it will hang easily upon the needle points. It is not to be clamped firmly, but allowed to rest so loosely that it may be revolved freely and even slid a very short distance back and forth.

### Operation of the Apparatus

After you have set up both stations according to the diagrams, have someone work the transmitter key, making regular test signals such as "V" or "D", and go to the receiver. Listen carefully to the telephone receiver, and move the graphite piece of the microphone around slightly. You will notice that you can hear every touch; when the microphone

is adjusted to its most sensitive condition there will be a continuous slight hiss in the telephone receiver, and even the slightest taps on the table or instrument base will be clearly heard.

When the apparatus is adjusted in this way you should hear the buzzes of the transmitter reproduced in your telephone, and so should be able to copy the signals sent out from the transmitting station.

If you have any difficulty in getting good results, try again with the receiver nearer to the sending station. When you have once transmitted good signals, move the stations farther apart. Remember that it is necessary to have good ground

connections, that the two tuning coils must be exactly alike, and that the sending and receiving antennas must be identical. If you are able to erect fairly large aerials for the two stations, such as, for instance, sixty foot lengths of wire supported by trees or poles, you should be able to transmit signals a

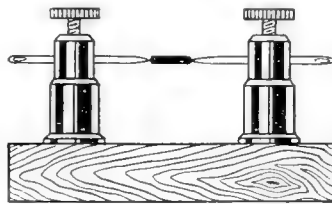

Fig. 3. How the Microphone Detector is to be Made

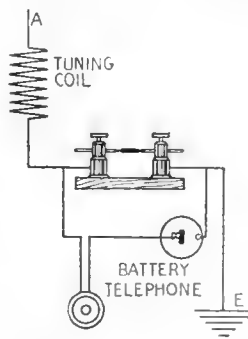

Fig. 4. How the Telephone Receiver and Microphone are to be Connected Together

distance of five hundred or a thousand feet; with larger aeralis even greater distances can be covered. Begin in a small way, however, and make your progress a step at a time.

If you are near a commercial or Naval wireless station you will be able to receive signals from it by using the apparatus of Fig. 4; better arrangements which will operate over longer distances will be explained in later articles, however. The microphonic detector of Fig. 3 is quite useful when connected to a commercial wireless tuner, and knowing how easily it may be built from material commonly at hand may be of value even to the commercial wireless operator, in times of emergency.

You will find it important to become a good telegraph operator if you propose to continue wireless experimenting. There are a number of pamphlets and books published which explain methods of learning the Morse code; Chapter IV of "The Book of Wireless," by A. Frederick Collins, gives a good method to follow. Cards showing the International Morse Code in full may be obtained from the Radio Inspectors' offices at Boston, New York, Baltimore, Savannah, New Orleans, San Francisco, Cleveland and Chicago. It is only by constant practice that you can become proficient.

(To be continued)

### A Rotary Adjustment for Coupling

A SIMPLE method of building a rotary adjustment for coupling of receivers is shown in the drawing, where *A* is the primary coil, *B* the secondary coil, and *C* indicates the slide rods for the secondary. At *D* is shown a small square brass rack which meshes with a

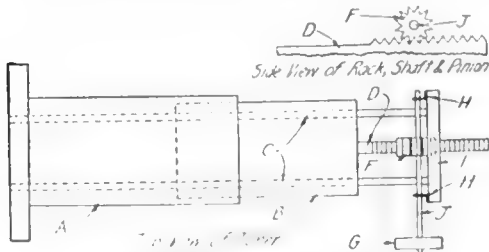

Arrangement of Coils in Rotary Adjustment for the Coupling Receivers

small pinion about  $\frac{1}{2}$  in. in diameter at *F*. The pinion is carried on shaft *J*, which is supported in small angles made of  $\frac{1}{16}$  in. sheet brass, as shown at *H*. A hard rubber or fiber knob is shown at *G*. The rack *D* may also be attached to the secondary coil with a small angle of  $\frac{1}{16}$ -in. brass. A hole should be bored through the end-piece *I* to permit *D* to slide through. The brass rack and pinion may be purchased from any dealers in model supplies. The arrangement will be found well worth the trouble of making, since a very fine adjustment of coupling may be invariably obtained.—C. H. RAUSCHENBERG.

### A Curious Form of Dustproof Detector Cup

IT is well known that detectors of the mineral type rapidly depreciate in sensitiveness when the minerals become covered with dust. A great many endeavor to overcome this nuisance by covering the detector with a jeweler's glass

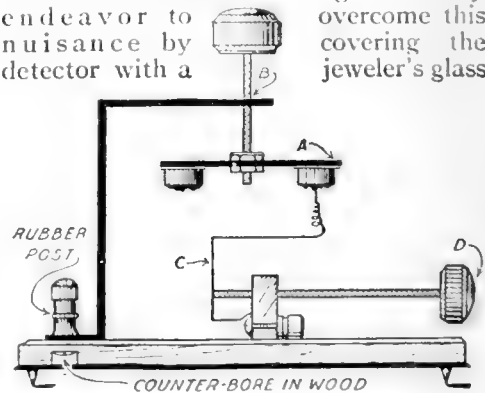

Scheme to Protect Detectors of the Mineral Type from Dust

bell or by other means. A new scheme is shown in the drawing. The mineral cups are placed on a brass bar or disk, *A*, supported by an adjustable threaded rod *B*.

A fine "cat-whisker" wire contact point of the usual type may be placed on a brass spring *C*, which has its tension adjustable by means of a threaded rod and knob *D*. At first this may seem a little inconvenient, but it really is just as easy to adjust as if the mineral cups were facing upward, as in most detectors. This is because the sensitive spots on the mineral are found by feeling around with "cat-whisker" contact.

# What Radio Readers Want to Know

## Announcement

*Beginning with this issue, the Editors are extending the scope of the Questions and Answers Department so as to include a Radio Readers' Service Bureau. Answers to any questions you wish to ask us will be sent by mail directly to you. Queries of general interest, with their answers, will be published monthly in these pages.*

*This new service is furnished free to our readers. The questions will be answered by authorities in the branches concerned. Your inquiries may be on any topic related to wireless telegraphy or telephony.*

*The Editors suggest, however, that queries as to the wave-lengths of aerials and the working distance ranges of various senders and receivers be withheld. These subjects have been explained so often that almost any desired information as to them may be found by reading over the earlier issues of the magazine.*

*What books to read, how to build apparatus, how to adjust it, and where to buy it, are only a few of the things we can tell you. If we can help you, write to us!*

### A Simple Wireless Telephone

L. N. P., Waynesville, O., writes:

Q. 1. Please state where I can obtain directions to make a simple wireless telephone set that will transmit to a distance of one or two miles. I desire an apparatus that does not include an arc gap or other expensive apparatus. Please give instructions for the construction of a simple set.

A. 1. You are advised to purchase a copy of "Simple Wireless Telephones and How to Make Them," on sale by the Book Department of this magazine. The price is 25c per copy.

A very simple wireless telephone set for amateur purposes may be constructed in the following manner: If you are already in possession of a wireless telegraph transmitting set, you can take the high potential transformer and connect it directly to the terminals or the spark gap, the latter in turn being connected in series with the antenna system. A microphone transmitter is connected in series with the earth lead for variation of the antenna current in accordance with the vibrations of the human voice. Due to the small capacity of the antenna the spark assumes the nature of an arc, and oscillations of an exceedingly high spark frequency flow in the antenna circuit. In fact they are of sufficient frequency to permit the transmission of the human voice. You should have no difficulty in covering a distance of one or two miles with this apparatus.

### Receiving Long Waves

M. M., Danville, Pa., inquires:

Q. 1. What is the wave length of my aerial which is 140 feet in length, 35 feet in height, consisting of two copper wires on four foot spreaders. The lead-in wires are 25 feet in length.

A. 1. The fundamental wave length is approximately 310 meters.

Q. 2. Please give the size and dimensions of a long wave length loose coupler to be used with this aerial.

A. 2. The longest wave length used by any spark station is that of the Marconi Company at Glace Bay, which employs a frequency wave length of 8,125 meters. In the November, 1915, issue and the April, 1916, issue of this magazine, there are described the complete circuits for an oscillating audion detector which will permit loud response from stations using damped and undamped oscillations, and you would secure better results by constructing apparatus of this type rather than a simple inductively coupled receiving tuner. However for crystalline detectors the tuner may have the following dimensions: The secondary winding 6" in diameter, 12" in length, wound with No. 30 S. S. C. wire. It is intended to be shunted by a condenser of .0005 microfarads. The corresponding primary winding is 7" in diameter, 12" in length, wound closely with No. 24 S. S. C. wire. The loading coil for the antenna circuit is 14" in length, 7" in diameter, wound with No. 22 S. S. C. wire.

### Sending on Short Wave

W. D. H., Olathe, Kansas, writes:

Q. 1. I have an aerial 50 feet in height, 200 feet in length, composed of a single wire. The lead-in is 35 feet in length and the ground lead 20 feet. Please advise how to construct a short wave condenser that will reduce the sending wave length to 200 meters. I use a  $\frac{1}{2}$  K. W. high potential transformer.

A. 1. The fundamental wave length of your aerial is approximately 360 meters which is rather long to be operated at wave lengths of 200 meters. In fact a series condenser will just barely reduce the natural wave length to 200 meters and will not allow turns to be placed in the secondary winding of the oscillation transformer. You are advised to reduce the length of the aerial to 130 feet and then if possible attach the lead-in wire to the center of the flat top portion. With this connection you can send at the wave length of 200 meters without a series condenser.



### Receiving Long Waves

F. F. L., New Rochelle, N. Y., writes:

Q. 1. I have an aerial of the inverted "L" type, consisting of four wires spaced  $2\frac{1}{2}$  feet apart. It is 58 feet in length, 50 feet in height at one end and 35 feet at the lower end. The lead-in is attached to the lower end and is 12 feet in length. The ground wire is 40 feet in length. The primary winding of the receiving transformer is wound with 255 turns of No. 24 S.S.C. wire on a cardboard tube  $3\frac{7}{8}$ " in diameter. The secondary winding is made on a tube  $3\frac{1}{8}$ " in diameter for a length of  $5\frac{3}{8}$ " with No. 30 S.S.C. wire. There are eleven taps on the primary winding. I use an Audion detector. Can you compute the wave length of the aerial and the possible adjustment with the receiving tuner described?

A. 1. The natural wave length of the aerial system is approximately 190 meters, and with the primary winding connected in series is adjustable to 1900 meters. The secondary winding with a capacity of .0001 microfarads in shunt will respond to 1600 meters and to about 3,000 meters with .0005 microfarads in shunt.

Q. 2. Can this antenna be loaded by means of inductance coils to receive Nauen, Germany, and allow the reception of their signals day and night with a sensitive oscillating audion? It is impossible to erect another aerial.

A. 2. It would be possible to load this aerial so as to secure response from Nauen, Germany, but the present receiving tuner will not afford sufficient closeness of coupling for the best response. You should construct apparatus like that described by A. J. Watts in the November, 1915, issue of the POPULAR SCIENCE MONTHLY. Also see the article by McKnight in the April, 1916, issue.

Q. 3. When using 101 turns of the primary winding, and five-sections of the secondary winding, with a correspondingly low degree of coupling, I obtained signals from the Brooklyn Navy Yard loud enough to be heard over two floors. When the entire primary and secondary windings are in use with a close degree of coupling, I get Arlington signals loud enough to hear them 20 feet from the head telephones. I also receive Brooklyn Navy Yard at this point just as loud as at the first mentioned adjustment completely drowning out Arlington. A change in the coupling or an alteration in the capacity of the variable condenser has the effect of weakening the signals from Arlington without a decrease in the strength of the signals received from the Navy Yard.

I experienced similar results with New York Herald and the Cape Cod, Mass., stations. Previous to this I owned a transformer with which I could cut out the New York Herald and still receive Cape Cod, but did not get any

stations as loud as those I can tune to with the present coupler. I also hear signals with this coupler that before could not be heard. I have tested the windings carefully for short circuits; do you think the phenomenon I have described is due to faulty construction or what is the cause of it?

A. 3. You will readily understand from the data we have given you that your receiving tuner cannot be placed in resonance with Arlington, although with a close degree of coupling you are able to hear these signals on account of forced oscillations. You should also understand that when a close degree of coupling is used between the primary and the secondary winding of a receiving tuner that the receiving circuits are broadly tuned and simultaneously responsive to a number of wave lengths. To place your apparatus in complete resonance with Arlington you require larger primary and secondary windings, or a load coil and larger secondary condenser.

Q. 4. Are the results obtained just as satisfactory when the primary winding is tapped every twenty turns and the variometer connected in series with the antenna circuit as with the ordinary method where two switches are employed for the purpose?

A. 4. Yes, it is somewhat better to use the variometer, as a rule.

### The Construction of Variometer Windings in Single Layers and in Multi-Layers

M. A., New York, N. Y., inquires:

Q. 1. In the construction of variometer coils, should they be wound in single layers or in multi-layers?

A. 1. If the coils are narrow and consist of but a few turns, it is practical to use a multi-layered winding, but if the variometer is to consist of a great number of turns of wire, multi-layered winding should be avoided.

### Requirements of Fire Underwriters Concerning Radio Installations

G. S., Richmond Hill, N. Y., inquires:

Q. 1. I am somewhat confused on the requirements of the Fire Underwriters in respect to radio installations. What are the dimensions of the lightning switch and the size for the corresponding earth wire? Can copper clad iron wire be used in place of copper wire?

A. 1. The lightning switch must have a current carrying capacity of 100 amperes and the ground wire must be at least a No. 4 copper wire. Iron wire of any description will not be passed.

# The Trench Marble Game and How It is Played.



**A**N exceedingly interesting marble game can be played by using the trench system of laterals.

The device is mounted on a board 9" x 20", preferably of soft pine, an inch thick. This has strips on one end and along the two sides which project an inch above the surface of the board. Between these strips are nine zig-zag walls, each an inch in width, or in height, which are arranged  $\frac{3}{4}$ " apart.

The detail drawing shows one of these strips in perspective. Each section, between the bends, is  $1\frac{1}{2}$ " in length, except the first section, which is  $\frac{3}{4}$ ". The chance element of the game is provided for by forming openings, at odd intervals, through the zig-zag walls. No two strips are alike in this particular.

Use heavy block tin, or No. 18 gage galvanized iron. After cutting each strip  $1\frac{1}{8}$ " wide and  $11\frac{1}{4}$ " long, make the seven cross marks where the bends are to be, as shown, and then cut out openings at the places indicated. Then, at each corner, cut a

triangular tip, or point, as shown.

Lay out the board, showing where each wall is to be placed, and with a hammer drive the tips into the board, after the wall is put in position. In this manner eight lateral trenches are formed which lead to the main trench at the opposite end of the board.

The knuckles of the hand must not pass beyond the end on the board in shooting. The player may select any

lateral in shooting, the object being to win the highest number. The device not only cultivates accuracy in shooting, but develops the element of speed.

When a marble is shot into a particular lateral it may or it may not follow along that course from end to end. Probably, if the marble should be allowed to roll by gravity along each lateral, it would not deviate. But the marble must be shot, and the result is that in passing the bends in the lateral it is thrown violently in the direction of the communicating trenches. For instance, player A made his shot into the lateral 5; at the second bend it was diverted to trench 10, and a little further on to lateral 25, only to be thrown back again into 10. The player B started in lateral 40, but the marble ended in the main trench at 15.

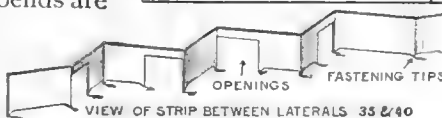
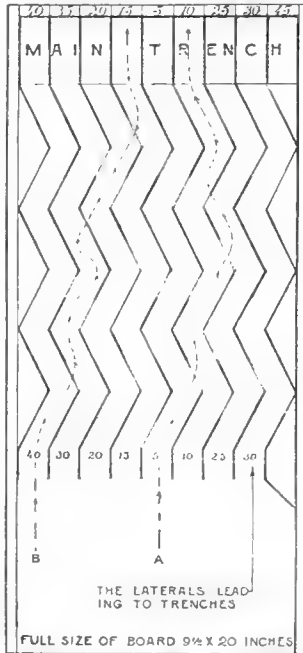

Strip Indicating Details of the Second Wall on the Playing Board

# Iceless Cooker and Refrigerator

DEPENDING upon the heat of the sun to reduce the temperature within a cooler or refrigerator may seem anomalous, but it has been proven scientifically to be possible. The warm summer days bring into prominence the important question of preserving food and keeping on hand a supply of cool water. This is an easy matter where ice and the receptacles for holding it are available; but it is very desirable to provide a means whereby a safe and positive method of cooling can be depended upon, without relying too much on the care which must be given to the use of ice. The illustration shows the application of the principle to a water cooler, Fig. 1; and also structurally arranged for a refrigerator, Fig. 2, or receptacle for holding food.

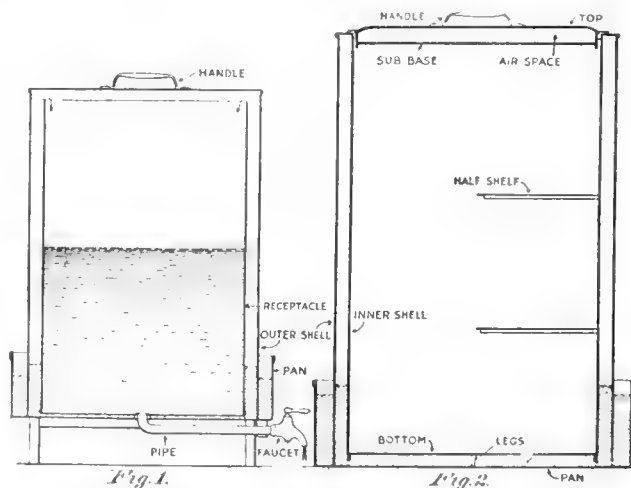

The Faucet Permits the Water to Be Drawn From the Shell Without Disturbing the Water in the Pan

The cooler may be made of heavy tin, galvanized iron, glass, or stoneware. For convenience the construction is of galvanized iron. It is exceedingly simple in design, and comprises a pan sixteen ins. in diameter and four ins. deep. Secured to this pan centrally is a receptacle ten ins. in diameter, and eighteen ins. high. The receptacle and pan are secured to each other by means of an L-shaped pipe, the short end of which passes through the bottom of each. With a washer between the two bottoms, the pipe is well soldered so as to make water tight joints.

The pipe extends out horizontally below the pan, and is provided with a faucet at its projecting end. A second

vessel twelve ins. in diameter with a depth of twenty ins. is inverted over the inner vessel, thus providing an annular air space of one in. around the vessel, designed to hold the drinking water. The outer shell has a handle so that it may be readily removed.

The refrigerator form, Fig. 2, also uses a pan twenty ins. in diameter, the sides being six ins. high. The body of the refrigerator is made of two cylindrical shells, the outer one being eighteen ins. in diameter, and the inner one, sixteen ins. Both are the same length, and two feet in height, joined together permanently at their upper ends by means of a rim. These two parts are provided with legs and the inner shell has a bottom one inch above the pan base.

It will thus be seen that water placed in the pan will flow into the space between the two shells, and also beneath the bottom. A top with a handle and a sub-base so as to provide an air space between, is adapted to fit snugly within the inner shell. One or more half-shelves may be placed within the inner shell.

In the cooler, water is also placed in the pan entirely separate from the drinking water which is in the shell.

The cooling principle may be stated as follows: The temperature of rarefied air is cooler than air at normal pressure. Condensation also plays an important part in the cooling process. The moment any water is drawn from the cooler shell the pressure of air on the surface of the

water in the pan surrounding the outer shell causes the water to flow up in the air space between the shells. The result is that the air within the water cooler is more rarefied than the air without.

At the same time, warm air on the outside of the shell, and cool air on the inside, produces condensation, which also assists in lowering the temperature within, the degree of cooling being dependent on the rarefaction and amount of condensation produced. It is this principle which is employed in the Mexican Oya, or water bottle, which is made of thick porous clay which "sweats" profusely, cooling the water within.

#### A Typewriter Desk Made from a Kitchen Table

A KITCHEN table was converted into a typewriter desk in the following manner: An 18-in. by 24-in. bread-board was purchased from the hardware store and some pieces of 1-in. by 2-in. soft wood obtained. Two pieces of the latter were placed across the under side of the table, from the back to the front boards, serving as guides for the bread-board. Two more pieces were fastened to the board near one end and arranged to fit over the side pieces.

The board was put in place as a shelf under the table and a final cross strip of the 1-in. by 2-in. board was fastened to hold the front in place and allow the board to slide under the lower edge of the front board.—E. W. HYMAN.

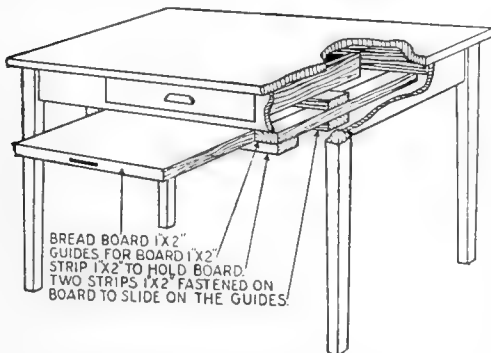

A Shelf of Correct Height for the Typewriter Has Been Added to the Table

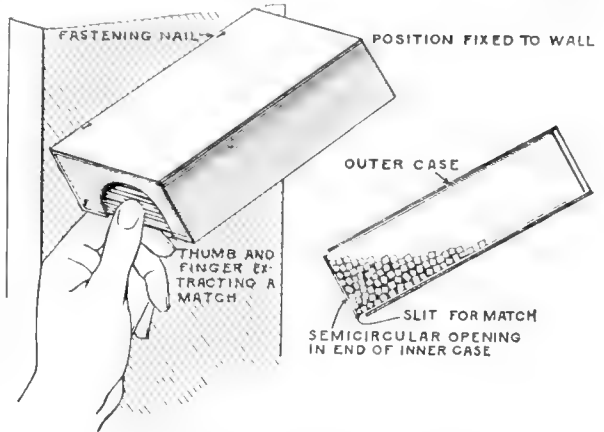

In This Position the Matches Gravitate to the Lower Exposure End of the Box

#### A Simple and Convenient Receptacle for Matches

A MATCHBOX which does not have to be opened and from which only one match at a time can be extracted, is shown in detail in the accompanying illustration.

The ordinary sliding carton is a most unsatisfactory contrivance for the reason that the greatest care must be exercised in opening it and removing the retarding strip. Every time a match is required both hands are necessary to open the box and extract it.

The new box has at one end and in the bottom a cut-out portion so as to expose the matches, only the ends being supported against the uncut portions of the box. In the corners, however, the box is slit so as to provide a means for drawing out the match.

In use the box should be secured to some object on the wall or wainscot at an angle by means of small nails driven in the upper corners. In that position all the matches will gravitate to the lower exposure end of the box in position to be grasped by the thumb and forefinger.

It is not a difficult matter to convert the ordinary box into a receptacle of this kind for permanent attachment to the wall. The sectional view shows how this may be done. In order to refill it from a new box the inner sliding portion only is removed, and when filled it is returned to the stationary case which is fastened on the wall.

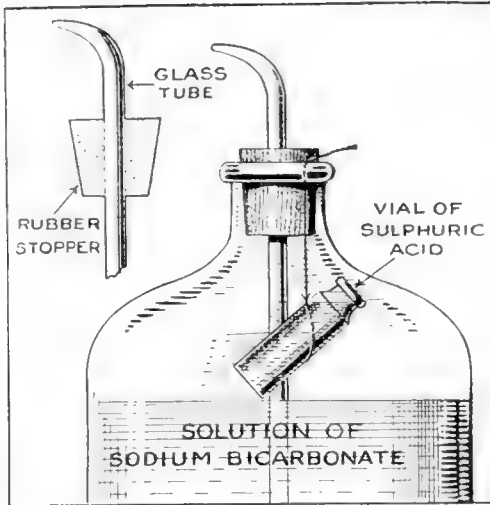

The Liquid is Thrown by the Pressure of Gas Generated in the Bottle

#### A Home-Made Fire Extinguisher

AN amateur mechanic can easily make a fire extinguisher to work upon scientific principles the same as do the ones used in large buildings. As in the larger extinguishers, the liquid is thrown by the pressure of gas generated by mixing a solution of soda (sodium bicarbonate) and sulphuric acid. The materials necessary are a bottle of about two quarts capacity, a piece of glass tubing a little longer than the height of the bottle, a rubber stopper to fit the bottle, and a small straight medicinal vial.

By the use of an alcohol lamp, one end of the glass tube is heated and brought to a point. The point is then broken off, leaving a hole in the end about one-sixteenth of an in. in diameter, and the tube is bent.

If you cannot procure a stopper with a hole in it, one must be drilled to fit the glass tubing, which should be about one-fourth in. in diameter. The next step is to push the tube through the stopper so that the end of the tube almost touches the bottom of the bottle when the stopper is in position. Tie a string around the small vial about one-half way between the middle and the open end. (See drawing.) To charge ready for use, fill the bottle with a solution of baking soda so that there is barely room enough to hang the smaller vial inside

the bottle clear of the solution. Next, fill the vial almost full of sulphuric acid and carefully lower it into the bottle, placing the stopper in tightly so that the string suspending the small vial is held firmly between the stopper and the mouth of the bottle. In case of a blaze, grasp the bottle tightly in the hands, give it a few vigorous shakes to mix the two solutions and direct the stream of water (charged with carbon dioxide) on the blaze and it will be quickly extinguished.—WAIN MARTIN.

#### A Towel Holder

A HANDY and practical towel holder can be made by the busy housewife. Remove the fasteners from worn-out and discarded garters and also the part that is attached to the stocking. Sew a small silver or brass ring to it. Fasten a towel to it as you would a stocking and hang it on a hook or a push-pin.

This holder can be used in places where a rack or rod might possibly be in the way.—WILL CHAPEL.

#### The Strap as a Jar Opener

UNSCREWING the tops of jars is a simple operation with the aid of a shawl or belt strap. The strap can not slip because the harder it is pulled the harder it grips the jar. If the main part of the jar can be held to withstand the pull of the strap the most obstinate cover will have to capitulate. Where the ordinary types of jar openers do not fit the strap is an effective substitute.

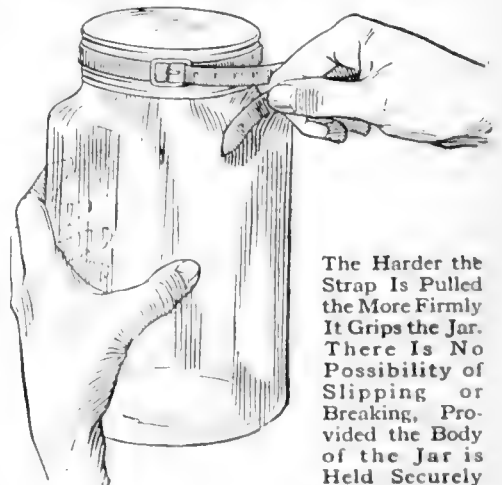

The Harder the Strap Is Pulled the More Firmly It Grips the Jar. There Is No Possibility of Slipping or Breaking, Provided the Body of the Jar is Held Securely

**A Convenient Shoe-Rack**

A STURDY shoe rack can be constructed as follows: Fasten a board along the wall, or if preferred, on the door of the bedroom closet, and then attach a metal strip as shown. The metal support may be of tin or sheet-iron, but if made of brass and nicked it will have a much better appearance. The shoes are hung by the heels.—  
GEO. W. GREENE.

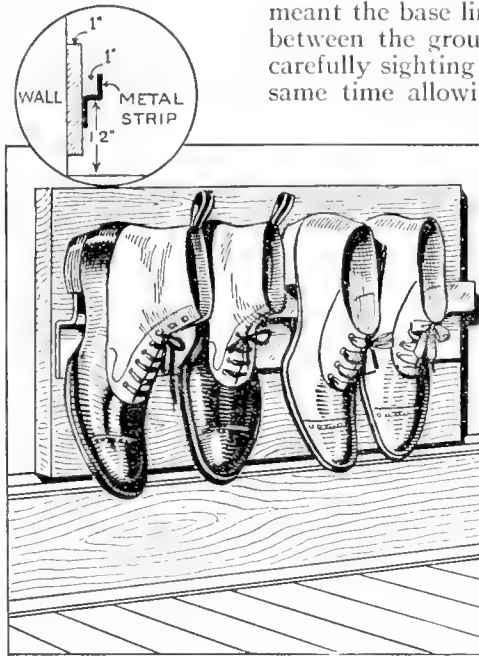

An Exceedingly Simple Arrangement for Keeping Your Shoes Out of the Way

**How to Calculate Distances**

IT is often necessary to measure approximate distances from one object to another quickly, as in photographing with a Kodak. An instrument that enables one to make such measurements can readily be made, using the angle of incidence as the principle upon which to work. Such a device, made according to the description, is simple and compact. It can be constructed either of hardwood, or sheet metal, cut to the size and shape shown in the illustration. Running along the top of the device is a sight tube, consisting of a small metal tube soldered or securely fastened with wire. A level, in the form of a metal hand, is fastened as shown, the hand being left free to swing back and forth along the face of the instrument.

The device is now complete, except for the markings, which are determined as follows: Selecting a level ground, a distance of 100 feet is measured off. Standing at one end of the measured distance, sight through the tube to the

base of an object placed at the other end of the measured distance. By base is meant the base line, or point of meeting between the ground and object. After carefully sighting in this manner, at the same time allowing the hand to swing free, the hand is now caught under a finger and pressed against the face of the instrument, to prevent further movement. A mark is now made at the point of the hand, and this indicates 100 feet in future measurements.

The other distances are measured in the same manner, care being taken always to be on a level ground; the measuring of the short distances can be done indoors very conveniently. Obviously, the nearer an object is to the observer, the more the instrument must be tilted to sight at the base line of an object, and vice versa. Therefore, to make accurate measurements of distances, the instrument must always be used by a person standing up straight, and one of the same height as the one who made the markings, for they would not be absolutely correct for anyone of different height. If

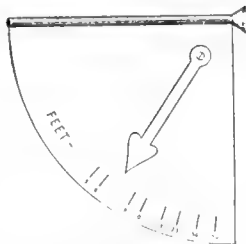

The Angle of Incidence Is the Foundation Principle

extreme compactness is not a requirement, the instrument can be fastened to a rod, with a pivot, and this pressed into the earth to form a support, thus allowing it to be used by anyone. The object sighted at should always be on a level with the observer, in order that the proper distance between the two may be found. Such a device is especially valuable to the amateur

photographer in determining the distance between his camera and the object to be photographed, and will greatly reduce the number of failures due to incorrect judging of distances.

# Photographic Self Help

## Pendulum for the Dark-Room

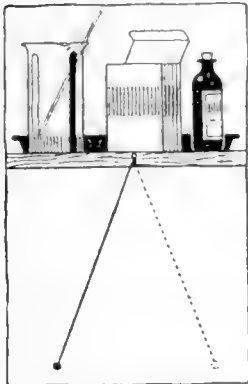

The pendulum swings from one terminal to the other in half a second

A SMALL weight fastened to a thread measuring  $9\frac{3}{4}$ " in length and having a loop at the end to be hung from a hook in the edge of a shelf, makes a capital aid in counting seconds for timing the appearance of the image in the time system of development. One second counts at one end of the swing

only, since the pendulum swings from one terminal to the other in half a second. The exact weight of the pendulum does not matter, the period of time depending upon the length, not the mass. This device may be so constructed as to count minutes. A small metal hand may be placed at the anchoring end of the pendulum. As the weight shifts from one terminal to the other the hand will be actuated against some object which will enable the operator to count the periods.

## An Improved Reflecting-Camera

A VERY simple arrangement can be fitted to a hand-camera to enable the photographer to see the image on the ground glass, right side up, and without the use of a focusing cloth, while still holding the camera in the hand. This consists of an ordinary mirror, on thin glass, cut to the same size as the ground

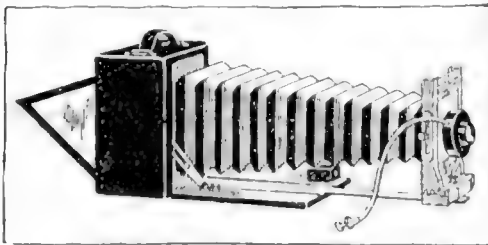

A mirror the size of the ground glass of the camera is mounted on the inside of the door

glass of the camera and mounted on the inside of the door covering the ground glass opening. The mirror is held at an angle of about  $45^\circ$  to the back of the camera by attaching a string or light chain to the door and the back of the camera. When it is desired to view the image on the ground glass the door is opened and allowed to drop down as far as the string will allow, and the eyes are placed at the top of the triangular opening thus provided. The image will be seen in the mirror, right side up.

## Novel Device for Copying Pictures

THE illustration shows a handy apparatus for copying pictures. A piece of groove siding is ripped in the center, and two pieces 12 ins. long are dressed on the edges. A piece of glass about  $10'' \times 16''$  is required. Two brackets are placed on the strips which hold the glass. Using an old drawing board the brackets and uprights are screwed in place, allowing space between the uprights for the glass. A strip of felt is placed on each narrow end of the glass, which is placed between the grooves. The copier sits directly facing the glass, after placing the picture on the table and securing it with thumb tacks. The reflection of the picture can be seen through the glass and copied.

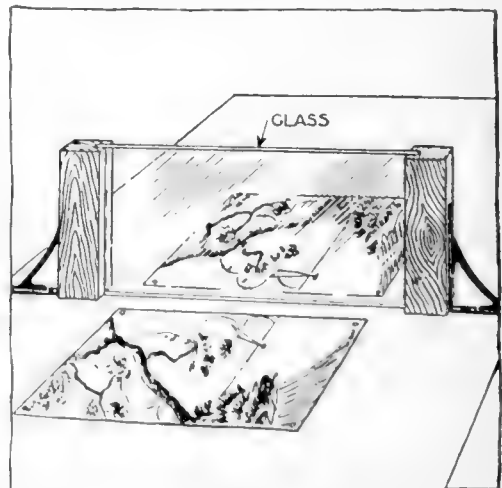

The picture is reflected through the glass and may be copied on blank paper with pen or pencil



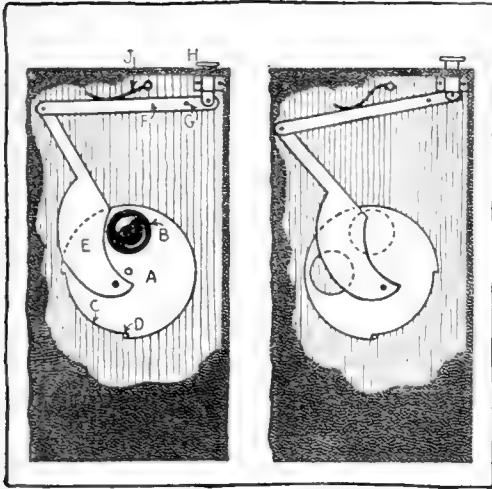

When the plunger is pressed the action opens the shutter, and when the plunger is released blade returns to its former position

### Home-Made Camera Shutter

A SHUTTER, which is suitable for a small hand-camera, can be made from odds and ends, and occupies a space  $2\frac{3}{8}'' \times 1\frac{1}{4}'' \times 1\frac{1}{4}''$ . The blade, *A*, is made of thin hard brass, painted dead black, loosely pivoted at the center by a small screw.

It is  $1\frac{1}{8}''$  in diameter, and it has a circular opening, *B*, for the exposure,  $\frac{1}{8}''$  in diameter. A narrow piece is removed at *C*, the corners coming into contact with the stop, *D*, consisting of a small screw. A lever, *E*, is pivoted to the circular blade at one end and to a second lever, *F*, at the other, the fulcrum of the latter being a screw, *G*. The shutter is operated by pressing the little plunger, *H*, and remains open until the plunger is released, when the spring, *J*, returns the blade to its former position.

### A Useful Trimming Board

A USEFUL cutting board for trimming photographic prints can be made from a scissors blade and a few odds and ends. The illustration shows the trimmer complete. The board is  $1\frac{1}{2}''$  thick and of any convenient area, with part of a flat rule *B* screwed along the top edge. A strip of steel is screwed along the right hand side, flush with the surface. An old scissors blade is secured by means of a screw which forms a pivot

or fulcrum, the necessary hole having been drilled through the end of the blade. It will be seen that the end of the blade has been ground blunt and the cutting edge straight. When cutting, the blade should be pressed towards the steel strip.

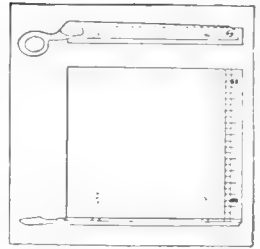

The complete trimming board for photographic prints made from a scissors blade

### Simple Test of Shutter Speed

THE following method of testing the speed of a camera shutter may be of interest to photographers who possess a bicycle. Invert the bicycle upon a suitable support in bright sunshine, and glue a small square of tinfoil to the side rim of one of the wheels. Set up the camera in a convenient position and focus this wheel sharply. Then open the diaphragm to its largest stop and set the shutter at its lowest speed. The wheel must be revolved at the rate of one revolution per second and a shutter exposure should be made while it revolves at that speed.

The wheel should then be brought to rest and a time exposure given on a second plate. This constitutes a check in the alleged speed of a shutter.

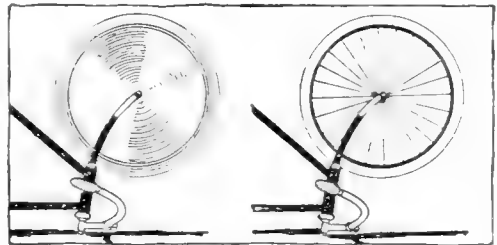

Using a bicycle, set upside down, to measure shutter speed

A test can be made several times, and the final results carefully compared and noted. It is necessary in all cases to make two exposures to determine the shutter speed. The method is sufficiently accurate for all ordinary purposes and with a pair of dividers to measure the width of the image, there is little opportunity to error.

### An Improved Vacuum Bottle

A NEW type of vacuum bottle made entirely of steel with a pure white porcelain enamel lining—will shortly be placed upon the market. The steel bottle is the invention of Mr. William Stanley, who perfected the bottle while engaged with other scientists, notably Dr. Irving Langmuir, in studying heat insulation.

This new bottle is non-breakable and the inventor claims about ten per cent. more efficiency for it than the glass bottles heretofore in use. It overcomes the well-known scientific fact that all metals have buried within them and condensed on their surface varying amounts of gases, which in their total amount to surprising quantities, being many times the actual volume of the metal. When a high vacuum is produced adjacent to a metal surface these gases free themselves slowly and for a long time continue to appear in the vacuous space.

The inventor believes that this phenomenon of occluded gas was responsible for the failure to obtain in metal-wall vessels results obtained in glass vacuum-bottles. He, therefore, obtained the desired result, not by spacing the inner and outer wall extremely close together, but by filling the vacuous space between the walls with a very finely divided metal so prepared as to be incapable of giving off gas at a vacuum or even to be absorptive of gas in the vacuum. By this procedure each air space enclosed between the granules of the finely fitted material becomes a vacuous space of which the granules form the vacuum walls.

The bottle is made by electrical welding which makes the joints not only vacuum tight but stronger than the sheet metal itself. Although built up of a number of parts this container is one solid metal unit when completed. The method of construction eliminates all danger of breaking at the joints. In fact the bottle is claimed to be practically indestructible under even the most strenuous usage short of smashing with an axe with malicious intent.

### Facilitates Boiling Water

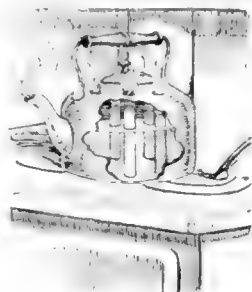

Vacuuous Space Filled with Finely Divided Metal

THIS novel idea of a tube-kettle will be found to give very satisfactory results where water is required to be boiled in one-third to half the usual time.

The sketch shows an ordinary kettle so fitted, five holes

being bored to correspond, both top and bottom.

In these holes tubes of half-inch to one inch bore are fitted, the bore varying according to the kettle's size, after which they are well soldered to prevent leakage.

Kettles fitted with these tubes are suitable for use on either gas stoves or a closed range, and are also rendered suitable for open grates by fitting corks in the top of the tubes to prevent any smoking.

Practically all kinds of kettles may be readily converted into tube-kettles in this way.—GEORGE M. HOLDEN.

### Using Waterproof Lutes

BOILED linseed oil, thickened with clay, asbestos, or red or white lead, forms a good waterproof lute. Care should be taken to make it thick enough.

Flaxseed meal made into a stiff paste with water is useful for steam connections and is easily applied.

Portland cement is waterproof only when given time for preliminary setting to take place. It is not generally impervious to water, and because of its colloidal character while setting, it seems incredible that it could ever act other than as a water-pervious diaphragm. When firmly set and dry, however, the colloid character is lost. For practical purposes, preparations containing metallic soaps or oil emulsions serve to render concrete approximately impervious to water.

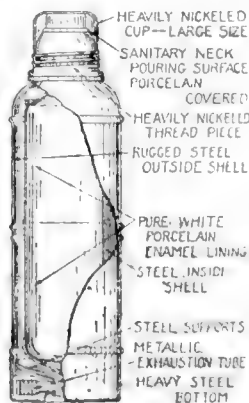

Water May Be Boiled in One-Third of the Usual Time

# For Practical Workers



## Boring Cylinders with a Lathe

THE average automobile repair man does not have a very extensive machine shop outfit, yet he is often called upon to do repair work of considerable magnitude with very ordinary equipment. After automobile engine cylinders have been in use for a time, the cylinder bore is apt to be worn or scored from a wrist-pin loosening. The only possible method of repairing a cylinder that has depreciated to that extent is to bore it out. A job of this nature was done on a 14-in. swing lathe by the use of relatively simple and inexpensive fixtures.

The repair man had several scored cylinder castings belonging to a car that is no longer manufactured, and as there was a number of these cars in use in the vicinity it was considered more economical to salvage the worn castings which were otherwise in perfect condition and have them in stock than it would be to purchase new parts. The cylinders, which were initially about  $3\frac{5}{8}$ -in. bore, were enlarged to  $3\frac{3}{4}$ -in. bore and oversize pistons and "leak proof" rings were fitted. The cylinder wall was of a ample thickness to permit boring.

The boring-bar guide used to support the open end of the cylinder block and the method of fastening this by clamps is shown in the illustration. The arrangement for feeding the cylinder-block by attaching it to the tool post of the lathe by means of a rod or key stock is also outlined. The other end of the key stock is clamped to the top of the cylinder and as the tool post carriage is fed down by the feed screw it is evident that the cylinder-block will also be pulled down on the boring-bar. The construction of the boring-bar and fixtures may be readily determined by examining the diagrams. A three-diameter boring-bar was used, two of the diameters being very accurately turned. The cylinders were provided with a threaded hole at the head end which was normally closed by a brass plug. This hole was furnished as a core print support when the cylinders were cast. A centering fixture was made to fit this hole.

This was a cup-shaped iron bushing having three equidistantly spaced set-screws bearing against a centering ring which was bored out to be a good sliding fit on the smaller

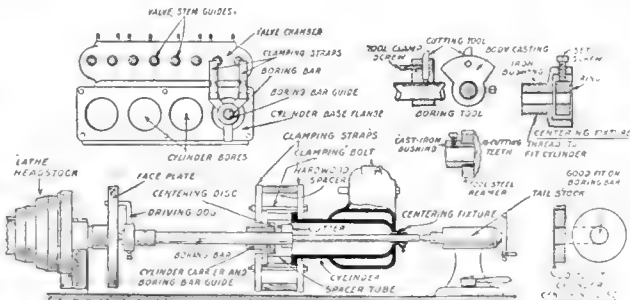

The Various Parts of Fixtures Used in Boring Out a Cylinder on a 14-inch Engine Lathe

diameter of the boring-bar illustrated.

A three-arm spider casting having a substantial boss was bored out to be an easy running fit on the intermediate diameter of the boring-bar. This was securely held against the cylinder base-flange by means of clamping straps. It is held away from the base-flange by tubular spacers while the clamping straps were separated at the top by hardwood spacer blocks. The boring tool was a special iron casting having an inserted cutting tool made of tool steel. The cutter was held in place by a set-screw and was inserted in a drill hole made to receive it. The boring tool was securely clamped to the intermediate portion of the boring-bar by a set-screw.

A special reamer was made to smooth the cylinder after the boring cut was completed. This was made of a tool steel disk having sixteen cutting teeth milled on it and forced on a cast-iron bushing which was a good fit on the boring-bar. The boring-bar was machined from a piece of machinery steel  $1\frac{1}{2}$  in. in diameter.

In assembling the parts, the first step was to put the centering disk into the cylinder interior and then locate the cylinder carriers and boring-bar guides. The centering disk was an easy push fit in the cylinder interior and, of course, held the boring-bar in the center. When the cylinder carrier was clamped to the base flange of the cylinder-block, and the centering disk was backed out and its place taken by the boring tool, the cut started straight. Absolute parallelism of the boring-bar with the cylinder walls was secured by putting the centering disk at the head end of the cylinder and then adjusting the centering fixture screwed into the core print hole so that the guide ring would support the head end of the cylinder properly on the small diameter of the boring-bar. After the centering disk had been moved to the open end of the

cylinder and the boring-bar guide securely clamped thereto, it will be apparent that the boring-bar center line had to coincide with that of the cylinder.

The cutting tool is set for the desired depth of cut, leaving about  $1/64$  in. of stock on a side to be removed with the reamer. The lathe is started on the back gears and the cylinder-block is moved back slowly to meet the cutting tool by

moving the tool post carriage with the hand feed. As soon as the cut is started the power feed is adjusted for a fine cut and the regular feed screw is used to bring the cylinder casting down. Only one cut is taken with the cutting tool, this being afterwards removed and the reamer substituted

to finish the job. As the cylinder-block floats on the boring-bar and as the guide members must be accurately located initially by the centering disk provided, the new bore must be true to size and the walls parallel to the center line of the cylinder.

It took about ten hours to bore and ream four cylinders or one cylinder-block. The setting up and locating took about two hours while the cutting occupied the remainder of the time. The cylinder flange rested on the ways of the lathe, this resisting the tendency of the cutting tool to turn the cylinder casting about the boring-bar. The weight of the casting was enough to prevent any vibration or chattering due to movement of the cylinders. In doing a job of this kind it is essential that the cylinder be accurately located on the boring-bar. The guide bearings should be thoroughly oiled and should be a good sliding fit on the arbor without having any vertical movement or shake. The boring tool should be carefully sharpened and it is absolutely essential that it be fed in slowly, so that only a fine cut will be taken. There is no necessity of blocking up the cylinder casting as this is adequately supported.—JOHN B. MAYNARD.

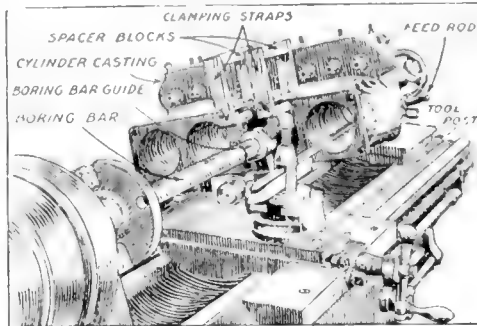

Boring-Bar Guide and Method of Fastening It with Clamps

How to Safeguard Mail Against Meddlers

TAKE an indelible pencil and make light lines—as shown in drawing—on the back of the envelope. Do not wet pencil when making the lines, and it is not necessary to bear heavily on the pencil; for if the envelope should be steamed the lines made with the indelible pencil will turn to a bright purple and remain plainly visible as shown in the illustration.

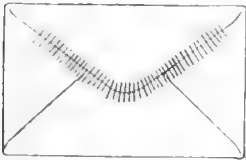

The Purple Lines Say, "This Envelope Has Been Steamed"

the indelible pencil will turn to a bright purple and remain plainly visible as shown in the illustration.

A Substantial Home-Made Jack

A SUBSTANTIAL jack of considerable lifting power is made with two pieces of 2 by 4 or 2 by 6 hardwood, two bars of steel or iron and a few bolts.

Cut one piece of the 2 by 4 about two or three feet long, according to the height desired for the jack. Cut another piece about 12 ins. long for the base, and fasten to the end of the upright piece, as in Fig. 1, by nailing or by mortising. Now bore  $\frac{3}{4}$ -in. holes near the edges of the upright on each side about 3 ins. apart and staggered as shown in Fig. 1. Put  $\frac{3}{4}$ -in. bolts in these holes with washers on both ends and screw nut up tight. It is best to use two nuts on each bolt.

Fig. 2 is a sectional side view of the upright, showing the bolt through the timber with two nuts holding it in place.

Procure two bars. One should be about 4 ft. long for the lever.

In this cut a notch about 4 inches from the end. The other bar is about two ft. long, with a chisel point on one end. An elbow bolt or large staple is placed near the top for the short bar to pass through to prevent the jack from kicking under a load. A 4-in. block is now cut and placed on top of the upright bar to prevent the bar cutting into the object being lifted. The lever bar with upright bar set in notch to prevent slipping is worked up from the nuts on one bolt to those on the bolt just above, as in Fig. 1. Dotted lines show different positions of lever bar in operation.—ROBT. F. STAYTON.

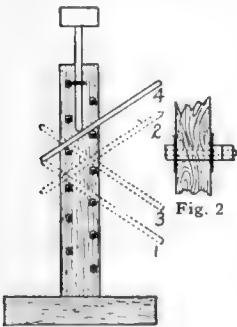

This Jack Will Not Kick or Cut Into the Object Lifted

under a load. A 4-in. block is now cut and placed on top of the upright bar to prevent the bar cutting into the object being lifted.

The lever bar with upright bar set in notch to prevent slipping is worked up from the nuts on one bolt to those on the bolt just above, as in Fig. 1. Dotted lines show different positions of lever bar in operation.—ROBT. F. STAYTON.

A Case for Miniature Lamps

PROCURE two pieces of wood 2 ins. by 6 ins. by  $\frac{1}{8}$  in. Draw a line lengthwise through the center and then mark off every  $\frac{3}{4}$  in. on this line.

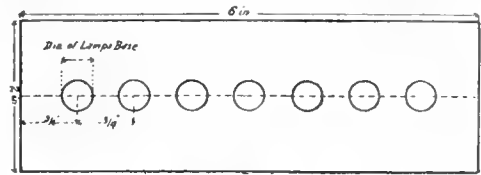

Fig. 1

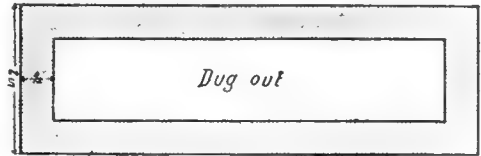

Fig. 2

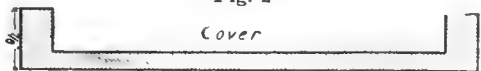
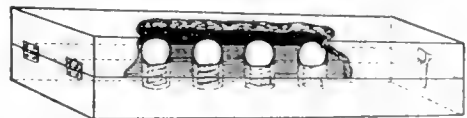

Diagram Showing Parts of Box Finished and Ready for Assembling

Drill holes with a bit the size of the lamp's base and drill them deep enough to allow the lamp to rest in, as in Fig. 1.

Take the other piece of wood and measure  $\frac{1}{2}$  in. from the edge on all sides, making a rectangle which is to be dug out to a depth of  $\frac{1}{2}$  in. This is shown in Fig. 2.

Next place the two together and fasten a small hinge to one end and a catch to the other end. The case is now complete except for sandpapering and painting.—CHARLES W. CHRISTMAN.



The Case Complete with Lamps in Position in Their Sockets

# Making a Wood-Turning Lathe

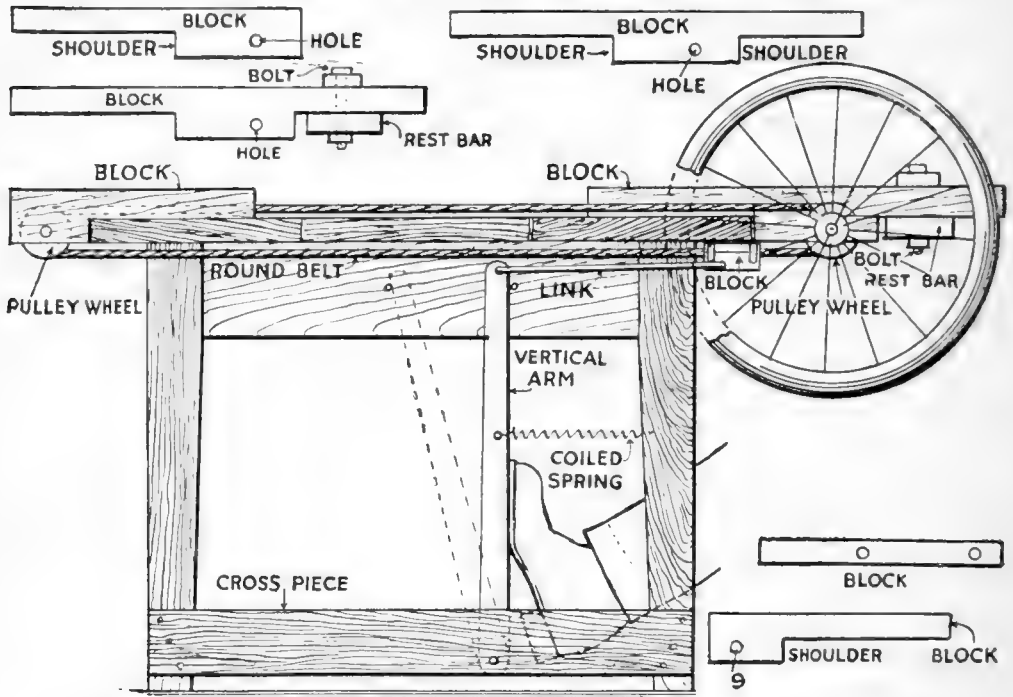

The Illustration Tells the Story of the Metamorphosis of an Old Discarded Kitchen Table Into a Piece of Machinery for Practical Mechanics

**I**N the corner was an old kitchen table. That was the only thing handy to be used as the framework in making a wood-turning lathe. A block of spruce 2 ins. thick, 3 ins. wide, and 15 ins. long was first prepared. This had one end thinned down for a distance of 6 ins., and the other end treated in like manner 4 ins. to a shoulder, thus leaving a part 2 ins. thick in the middle portion, through which was bored a cross hole with a three-eighth bit, 3 ins. from the shoulder. A slot 1 in. wide was then cut through the block, extending in 7 inches.

Another block 2 ins. thick, 11½ ins. wide, and 11 ins. long, had one end thinned down to correspond with the thinned portion of the first block, and a hole bored through to register with the hole in the first block.

These two blocks are screwed to the table top at its corner, and the holes are in line with each other to receive the mandrel. Obtain 2 pcs. of round three-

eighth steel, one 12 ins. and the other 4 ins. long. Also obtain a couple of V-grooved pulleys. A bicycle repairer can fasten them to the mandrel and spindle. One of them was secured to the mandrel 5½ ins. from the end, and the other was fixed to the spindle midway between its ends.

One end of the mandrel thus made was filed square, and the other end of the mandrel carried the bicycle wheel which was easily attached. Two blocks were then made, each of 2 by 2-in. material, 10 ins. long. The lower side of each was then thinned back a distance of 6 ins. from one end to the shoulder and a cross hole with a three-eighth bit bored through the thick part of each block, so they registered. These blocks thus served as bearings for the spindle, so the wheel was located at the rear edge of the table, directly in line with the wheel on the spindle at the front edge of the table.

To impart motion to the mandrel, a hardwood block was cut out, 2 ins. long,

$\frac{3}{4}$  in. thick, and  $\frac{1}{8}$  in. wide. A  $\frac{1}{4}$ -in. hole was bored through this from end to end above the center or middle line. A pair of links of thin metal on each side were attached by pivot pins at the ends to the sides of the block, and afterwards one end of each link was detached and the block sawed through along the bore, after which the block was placed on the round belt, which connected the two grooved pulleys, and the ends of the links again attached.

By this arrangement the two parts of the block move back and forth a limited distance independently of each other, and in doing so clamp the belt between them. A triangularly-formed stop was attached to the upper member of the block, so that one edge projected down alongside one of the links, and thus limited the movements of the blocks relative to each other. The dotted lines show the swing of the links when the lower part of the block is drawn to the left.

To move the lower part of this block to the left, and thus grip the belt, attach a cross-piece by nailing to the lower ends of the table legs. The upper end of this arm is connected with the block by a link which is made of  $\frac{1}{8}$ -in. telegraph wire. A coiled spring with one end attached to the arm and the other to the table leg, serves to draw the upper end of the arm back, when it is released by the foot.

The dead center was fixed to a block similar in all respects to the first block and is secured to the top of the table by screws so it can be moved to and from the block. A rest bar with a series of holes was adjustably attached to the lower sides of the blocks by bolts so it might be moved to or from the lathe centers. The square end of the mandrel, if driven into a round  $\frac{5}{16}$ -in.-hole in the end of the piece to be turned, holds it firmly, and this method of attaching the work obviates the necessity of having thrust bearings for the mandrel and dead center.—J. S. ZERBE.

### A Bottle Pocket Lamp

A SIMPLE and safe pocket lamp that will last for about six months without extra cost can be made at home.

Have the druggist take a strong vial of clear glass, or a pill bottle with screw or cork top, and put into it a piece of phosphorus about the size of a pea and fill the bottle one-third full of pure olive oil which has been heated for fifteen minutes. Care should be taken not to boil it. Cork tightly, and the result will be a luminous light in the upper portion of the bottle. If the light becomes dim, uncork and recork again. The lamp will retain its brilliancy for about six months, and there is no element of danger in connection with it.—A. V. BOLLERER.

The Method of Attaching the Work Which Is Indicated Here Obviates the Necessity for Having Thrust Bearings for the Mandrel and Dead Center

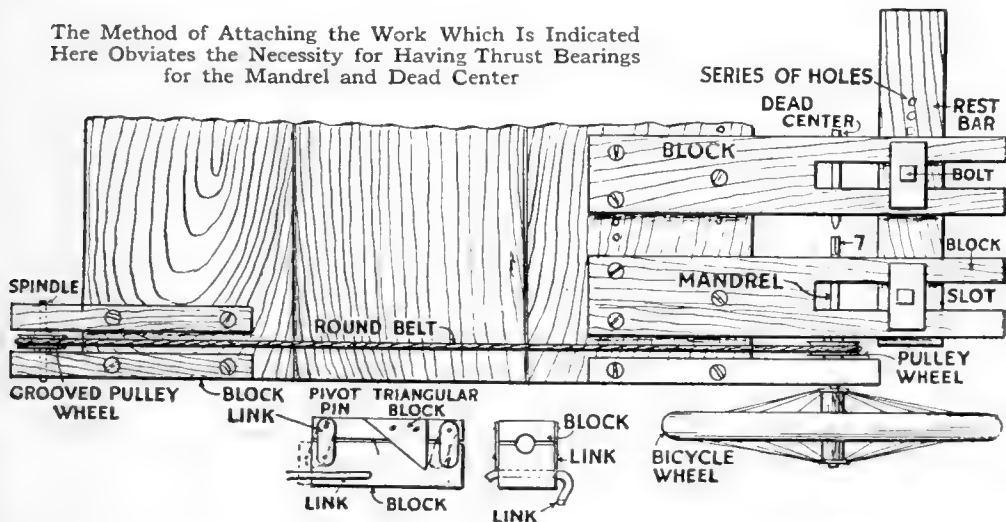



### An Easily Constructed Holder for the Broom

A SIMPLE little article which may be made by a novice from a few pieces of wood is a holder for a broom. It is designed to lengthen the life of the broom by saving the wear on the bristles and also to operate automatically.

Take a board 5 ins. by 7 ins. by  $\frac{1}{2}$  in. thick, and round off the top  $1\frac{3}{8}$  ins. to hang up holder, as shown in the illustration. Take a 1-in. board  $5\frac{5}{8}$  ins. by  $2\frac{3}{4}$  ins., cutting out a slot,  $\frac{3}{4}$  in. from the top,  $1\frac{3}{4}$  ins. wide, tapering to 1 in. at  $\frac{3}{4}$  in. from the bottom. Cut out a circular disk 1 in. thick and  $1\frac{7}{8}$  in. in diameter and place this in the slot. Nail on the long edge a 1 in. strip,  $\frac{7}{8}$  in. wide, which will leave a space  $1\frac{3}{8}$  ins. wide between the strip and part containing the circular disk.

To complete, nail across the front a piece of  $\frac{3}{8}$ -in. board  $2\frac{3}{4}$  ins. by  $5\frac{5}{8}$  ins.

When hanging up the broom place the top of the handle in the groove, push upwards, and let go. The circular disk will fall into place, securely locking the handle. To release broom, push upwards.—HENRY C. FRANKE, JR.

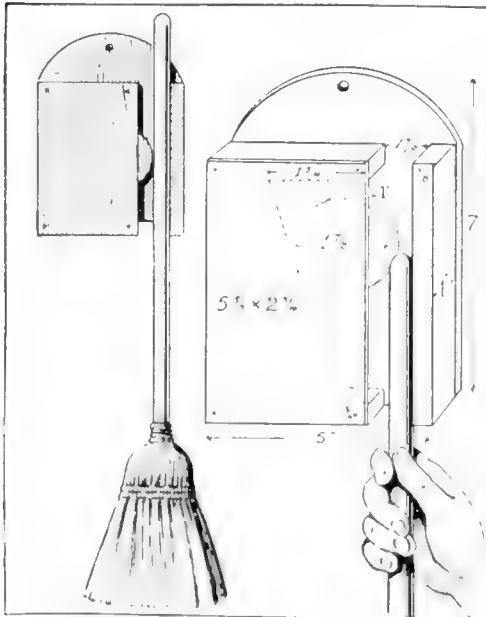

Showing the Automatic Action of Circular Disk Which Holds Broom in Place

### A Weed Destroyer from a Spoon and Broom-Handle

A HANDY weed destroyer for use on the lawn is made of the handle of an old kitchen spoon and a broomstick. The eye of the spoon handle is cut out with a file, leaving two prongs, as shown and the inside edges are then sharpened and the small end of the handle is set in the end of a broomstick, Fig. 1.

With this tool one may easily and quickly cut off small weeds an inch or so below the ground without disturbing the sod.

If one prefers to pull the weeds, simply

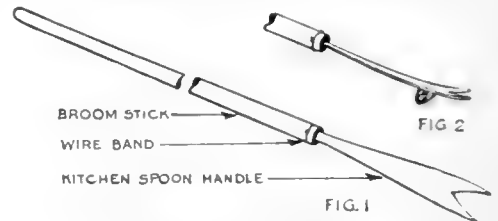

The Two Prongs are Sharpened so They May Be Used Simply to Cut Off the Tops or to Uproot Weeds

nail a small block of wood to the underside of the tool near the prongs to form a fulcrum, Fig. 2. The weeds may then be pried out of the ground, roots and all.—F. H. LINTHUM.

### Correcting Pliers Which Bind

ELECTRICIANS know how tiresome and annoying are pliers that are difficult to operate. This binding results because the pliers have been dropped upon a hard surface or have been held in the flame of a blow-torch when holding terminal lugs for soldering.

This trouble can be remedied by wrapping a wet rag around the jaws, and leaving the joint exposed. The joint is then heated in the flame of a blow-torch, care being taken to have the rag thoroughly wet while heating, to avoid drawing the temper out of the jaws.

When hot, remove the rag and immediately plunge the pliers in cold water, closing and opening the jaws to their full width until they are cold. Dry thoroughly, and apply oil to the joint by working it in. After this process your pliers will work as easily as ever.—GEORGE NIEDERHOFF.

# A Child's Morris Chair

THE drawing and illustrations are for a Morris chair suitable for a child from six to twelve years of age. A number of them have been successfully made in the eighth grade of New York City schools.

With slight changes in the dimensions, such as one inch added to the length of the legs, and an inch wider and deeper, the chair fits a boy or girl from twelve to fifteen years of age.

All the lumber can be bought milled to exact dimensions, given below.

## BILL OF MATERIALS

Finished dimensions:

4 Legs . . . . .	$1\frac{3}{4}"$ x $1\frac{3}{4}"$ x $16"$
2 Front and back rails . . . . .	$\frac{3}{4}"$ x $3"$ x $17\frac{1}{2}"$
2 Side rails . . . . .	$\frac{3}{4}"$ x $3"$ x $18"$
2 Arm pieces . . . . .	$\frac{3}{4}"$ x $3\frac{1}{2}"$ x $26\frac{1}{2}"$
4 Slats (for sides) . . . . .	$\frac{3}{8}"$ x $4"$ x $7\frac{1}{4}"$
2 Supports for seat . . . . .	$\frac{3}{4}"$ x $1\frac{1}{4}"$ x $14\frac{1}{2}"$
2 Stiles for back . . . . .	$\frac{3}{4}"$ x $2"$ x $18"$
4 Rails (for back) . . . . .	$\frac{3}{4}"$ x $2"$ x $9\frac{1}{2}"$
2 Front pieces for seat . . . . .	$\frac{3}{4}"$ x $2"$ x $12\frac{3}{4}"$
2 Side pieces for seat . . . . .	$\frac{3}{4}"$ x $2"$ x $15\frac{1}{2}"$
4 Brackets . . . . .	$\frac{3}{4}"$ x $1\frac{1}{2}"$ x $2"$
1 Stick (rest for back) . . . . .	$\frac{3}{4}"$ x $\frac{3}{4}"$ x $18"$
1 Dowel rod . . . . .	$\frac{1}{2}"$ diameter

The cost of all lumber and upholstering, including a good quality of imitation leather for the seat and back, amounted to \$1.75.

Begin by laying out all mortise and tenon joints on legs and rails. The tenons are  $1\frac{1}{2}$  ins. long and the mortises are  $\frac{1}{4}$  in. from the outside of the legs. The ends of the tenons are beveled, 1 in. from the shoulders, so as to obtain the largest possible gluing surface. The slats at the sides are not tenoned but "housed in," making the mortises in the rails very accurate. This extra care saves the time which is required if tenons are cut on the slats.

The legs are tenoned and project  $\frac{1}{8}$  in. above the arms. Four brackets shown in the drawing are glued under the arms and help to strengthen them.

While the parts are gluing, the back is made and assembled. The parts of the back are doweled and glued. When finished it is hinged to the back rail as shown in the drawing. This enables the back to fold forwards as well as backwards, and prevents it from being wrenched off.

At the rear end of the arms are three plugs which are mortised in, to a depth of  $\frac{1}{2}$  in. in front of where the cross stick rests which adjusts the back to different angles. Great care must be taken in laying out and gluing these plugs, as they must be exactly the same distance from the rear legs.

To finish the chair, scrape and sandpaper all surfaces. Be sure to remove all surplus glue. Choose color of stain desired. An oil stain is the easiest to apply and will give satisfactory results. After applying the stain wait until the gloss disappears, then rub down with cotton waste. Allow the chair to dry for forty-eight hours, then apply two thin coats of shellac, and rub down with 00 sandpaper, 00 steel wool. A few drops of sweet oil on the sandpaper will improve the polish.

The seat rests on cleats fastened to the front and back rails. The cleat on the back rail should be about an inch lower than the one on the front rail.

The seat is made as follows: Construct a frame of material, 2 ins. wide and

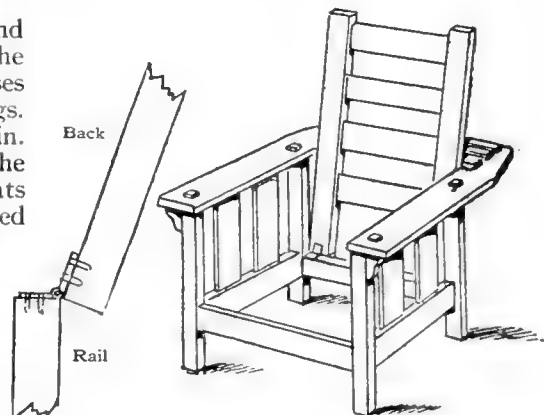

The Framework of the Chair Completed  
To the Left is the Hinge Connection

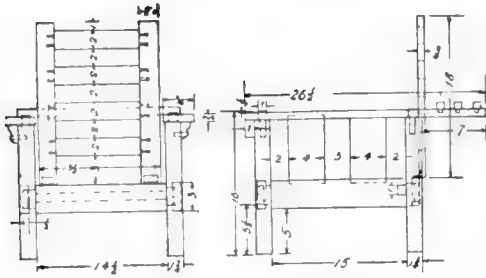
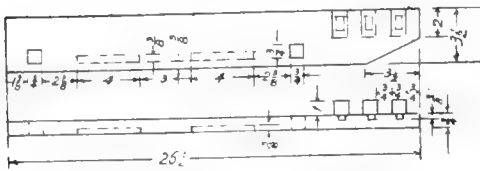

Diagram of Framework Before Assembling, Indicating Proportions and Process of Construction



At the Rear End of the Arms Three Plugs Are Mortised In. In front of These the Cross Stick Rests

large enough to fit the chair. It should not be flush with the front rail, but an allowance of  $\frac{1}{4}$  in. should be made for the covering. Upholstering springs can be bought to fit the frame. After nailing on the springs, cover the frame with a particularly strong piece of burlap or canvas.

On top of the canvas, spread about a pound of cotton felt, moss, or hair, and cover the whole with leather or a good quality of imitation leather, which can be tacked underneath the frame of the seat. Use 6-oz. upholstering tacks. Be sure to stretch the leather and see that no wrinkles are formed. For the back sew up a cushion and stuff it with cotton felt. When cutting the material for the cushion make it about 3 ins. wider than the distance between the arms, so as to allow for the seam and the stuffing which tend to contract the cushion. This additional width also gives the cushion space to spread when a heavy person sits in the chair.

This comfortable chair will present an excellent example of craftsmanship and will make a fine Christmas gift, the season for which will be here almost before you can realize it. So it is none too early to get busy at the workbench.—ANTON BUCHBINDER.

### An Efficient Tin Pump

A TIN pump can be made by taking a piece of brass tubing two ins. thick and seven or eight ins. long for the cylinder. A piece must be turned in the lathe to stop up one end and furnish a bearing for the cylinder to rock upon. Next a plunger-rod and piston should be made.

The best way to make the piston is to turn out washers about  $\frac{3}{16}$  ins. thick, with one slightly smaller than the inside diameter and the other  $\frac{1}{4}$  in. smaller to allow for the leather cup. Both of these washers should be tapped with a  $\frac{3}{8}$ -in. thread.

The plunger-rod is made about one inch longer than the stroke and a hole  $\frac{1}{4}$  in. is drilled in the outer end. A small cap or guide for the piston-rod is then turned to fit in the cylinder and is held in place by three screws. A hole  $\frac{1}{4}$  in. is then bored at the base of the pump and a small tube soldered or threaded in to carry the rubber hose. These fittings can be taken from an old discarded bicycle pump.

Next a board eighteen ins. long and five ins. wide is used. A piece of band-iron 1 by  $\frac{3}{16}$  is bent and drilled to act as a bearing for the pump. A handle three feet long is shaped and two iron bands drilled and bolted at the base to form a bearing for the handle to rock back and forth and carry the pump-rod. A small slit is cut about eight ins. from the base of the handle and a bolt is run through. This is to hold the pump-rod. A bent iron bearing is made for this handle the same as for the pump itself.

The amount of leverage can be regulated by the length of the handle and the distance of the plunger-rod from the base. This pump takes about one-half the energy that an ordinary tin pump requires.



The Pump Completed and Ready for Operation. The Amount of Leverage Is Regulated by the Length of the Handle and the Distance of the Plunger Rod from the Base. For Ordinary Use the Length Is About Three Feet

Scale Reading Calipers

IN the shop it is often necessary for the workman to read dimensions from blueprints that are half size, three-quarter size, etc. The usual practice is to caliper the dimension, transfer it to a ruler, and multiply it in order to get the actual size. It is a very simple matter to fix up your calipers so that they will be

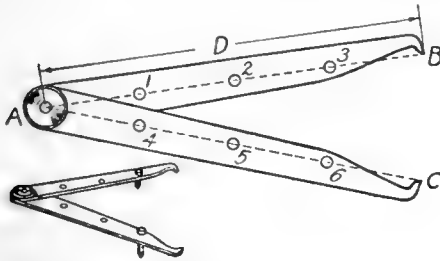

Method of Improving Calipers So as to Eliminate Involved Calculations

ready directly, thus giving the full size without any calculation.

Measure accurately the distance *A, B,* and divide it into four equal parts. In the same way lay off points on *A C.* These points should be in a straight line, from *A* to *C,* and from *A* to *B.* Holes should then be drilled at these points and tapped to take small long machine screws. Be careful to drill the holes perfectly straight and perpendicular.

Now put the machine screws in the holes. If  $\frac{1}{2}$  scale is to be read, place them in No. 2 and No. 5; then the distance between the ends of the dividers is just twice that between the machine screws. To read  $\frac{3}{4}$ , use holes Nos. 3 and 6. Nos. 1 and 4 give  $\frac{1}{4}$  size.

The time spent in making this improvement will be more than saved in actual use.—R. L. KENYON.

Soldering Iron for Light Work

A SOLDERING copper for light work can be made from a length of trolley wire one end of which is filed to a point and the other end bent to fit into a wooden handle.



The Completed Iron, Showing Simplicity and Neatness of Its Construction

Making a Driving-Box Lifter

THE device which is illustrated herewith is designed to be used for lifting driving-boxes with a traveling crane, for use with planers, boring-mills, drill-presses and the like. It is made from two forgings and a  $\frac{3}{8}$ -in. chain. The two rectangular links are made from  $\frac{3}{4}$ -in. iron. The ring is made first, then the rectangle, and lastly the two are welded. The link slips over the driving box and the ring is used in the crane hook.

Just as soon as the crane hook is hoisted, the two links are drawn together. An accident is practically impossible. The size of the link can be made to fit any driving-box, though it can be used for any box it will go over, unless the box happens to be very much too small.—JOSEPH K. LONG.

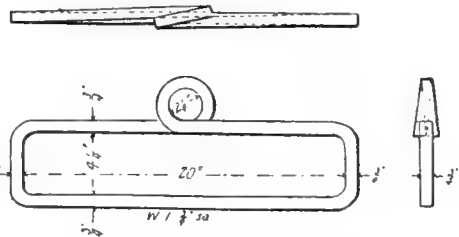

Welded Link Made to Fit Any Driving-Box for Lifting Purposes

Guide Lines for Lettering

THESE may be ruled by means of a simple left and right gliding movement. Several groups of holes may be drilled in the triangle, thus providing a simple and rapid means of ruling guides for several sizes of lettering. An advantage of this little scheme is the perfect uniformity of the spacing which is obtained.—W. H. SCHEER, JR.

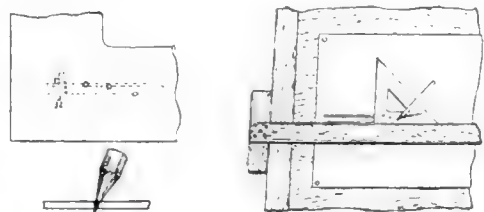

Arrangement of Group of Holes in Triangle and Device in Operation

## Getting a Line on Biddy

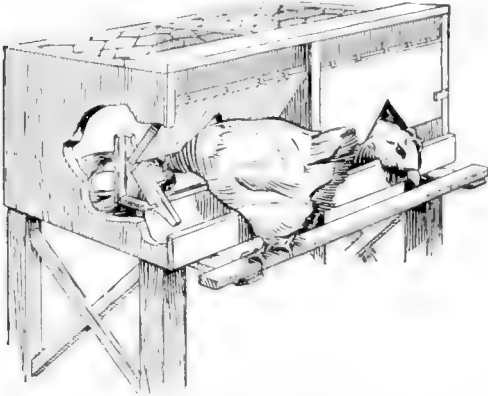

One Nest Shows the Hen Entering. The Other Shows the Door Automatically Locked

**T**HIS is an illustration of a trap nest—not a guillotine. It is designed to help the poultry breeder to find out his good layers and to keep pedigrees. It is very simple. It may be attached to the underside of the dropping board, with the front facing the pen and arranged so that it can be easily removed. The dropping board will then be the roof of the nest.

The rear of nest may be of wire for the sake of ventilation. If the nest is placed on the wall, slats or wire should be inserted from the front of the nest to the wall at a sharp angle to prevent the hen from roosting on the nest. When she enters the nest, the hen's back raises the door, which releases the catch and allows the door to shut. The catch should be set so that its edge just holds the door, the position being regulated by a screw or nail at the lower inside edge of the catch. A washer on the screw will prevent it from sticking. The guard around the catch holds the nesting material away. The nest should be visited frequently to release the hens.

## Boiling Water by Cooling It

**N**OT a little entertainment can be derived from a burnt-out incandescent light bulb. The spur of glass on the big end is hollow. While you hold that part under the hottest water in which you can keep your hands, carefully file off the point of the bulb. As soon as the water reaches the hollow part, it will enter and immediately

begin to boil. This is because the extremely rarefied atmosphere inside lowers the boiling point to the temperature of the water. As soon as the space is filled with steam, the boiling ceases.

Still keeping the opening under water, or closing it with a moistened finger, hold the bulb under a stream of cold water. The boiling immediately begins again, because the cold water condenses the steam, thereby leaving a partial vacuum.

By closing the opening securely with sealing wax when the bulb is about one-fifth full of water, you will have a very novel and interesting toy. When the water has cooled, inverting the bulb sends the water to the other end with a sharp click. In physics, a similar apparatus is called a water hammer.

The water can be made to boil at will by heating it gradually in a vessel of warm water, and you can always show how water can be made to boil by cooling.—E. P. THORNTON.

## To Find Your Depth

**T**HE depth gage illustrated will be found useful for many purposes. It consists of a steel knitting-needle, *A*, passed through two slots, *B C*, in a sheet of copper, the lower edge of which is perfectly straight. If the metal is placed on a piece of soft wood and indented between the slots *B C*, then turned over and similarly treated above and below the slots, a groove will be formed which will accommodate the needle while holding it with sufficient grasp to retain any measurements.

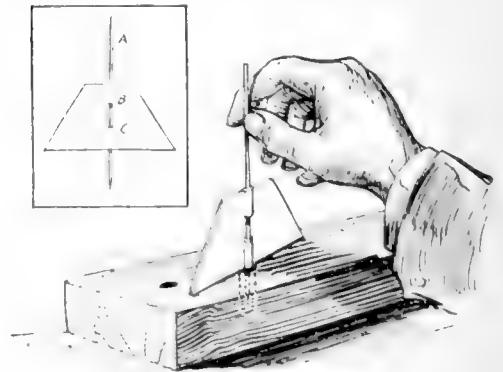

An Indentation in the Metal Forms a Groove in Which the Needle is Grasped.

Cheap Photographic Changing Box

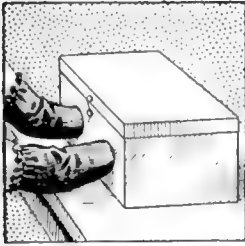

Plates Can Be Handled in Broad Daylight

**P**HOTOGRAPHERS who adopt the tank method of development and so dispense with all the trouble incidental to the older method, can very well do without a dark room except for the purpose

of loading and unloading the plate holders. By means of the box illustrated on this page, plates can be handled both before and after exposure with perfect safety in daylight, a dark room being entirely unnecessary.

The box should be oblong, and may be made of thin wood or cardboard. The writer has found a hat box satisfactory for a 4-in. by 5-in. plate outfit, and has in fact used such a box for years. A swing back lid, opening above is the best type. Two circular holes must be cut in one of the sides, large enough to admit the hands easily. A couple of short sleeves, made from black twill (double thickness) must be sewn over these holes securely with stout thread.

The box must be made thoroughly light-tight by covering both inside and out with black cotton lining, to be purchased at a dry-goods store. The corners and the angles formed by the sides should be strengthened with additional strips of the same material, because pinholes are more likely to develop here than elsewhere. A ring of black cloth must also be glued over each of the holes over which the sleeves were sewn, so as to cover any small holes left by the needle.

Particular care must be taken to make the lid fit light-tight. In the case of a hat box the lid is always loose fitting and there is plenty of room in which to sew a piece of black cloth, folded twice, all around the edge of the box. A very simple device may be used for keeping the lid closed while in use. A brass paper fastener should be passed through the side of the box and another through the lid. A few inches of stout thread with a button attached should

be tied round the former, the thread being passed twice round the head of the upper fastener to close the lid.

All the plate holders that are to be filled and the unopened packet of plates (or the plate holders after exposure and the developing tank), must be put into the charging box before closing the lid.

A damp sponge can be kept in a small saucer in the corner of the box for moistening the finger tips, when by touching the extreme corner of each plate, the gelatine will be felt to be sticky.—H. J. GRAY.

An Automatic Faucet for Tanks

**A**N automatic faucet may be constructed by anyone with the proper pipe-fitting tools.

In the drawing a bicycle sprocket is screwed on to the shank of an ordinary spigot-plug which has been previously threaded to receive it and a lock-nut.

A piece of bicycle-chain is shown on which are suspended two equal weights the former of iron or any heavy material and the latter of wood or something buoyant. To open the faucet the string supporting the wooden weight is pulled down, turning the sprocket to the left and opening the plug. As the water approaches the top of the tank the wooden weight is raised on the surface, allowing the other to descend, closing the spigot automatically.—F. A. WILHELM.

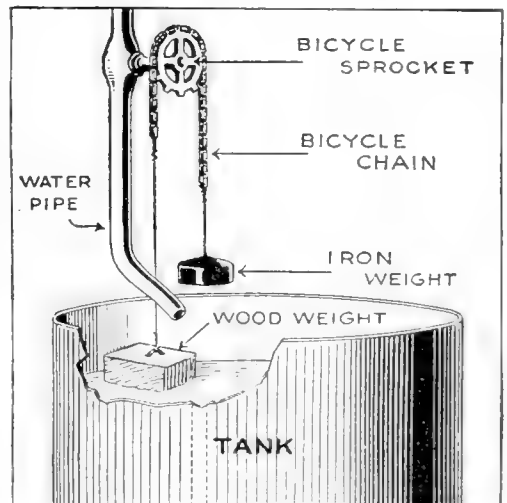

A Pull on the String Supporting Lighter Weight Opens the Plug

# The Use of Jigs and Fixtures

By S. H. Samuels

THE average person conceives of "tools" as drills, taps, reamers, etc., but modern automatic machinery has necessitated the use of jigs and fixtures for reproduction work. In

jigs and fixtures would be unpractical and extravagant. When large quantities are to be produced and sent upon the market, however, the results are surprising. The cost is reduced from 50



Fig. 1

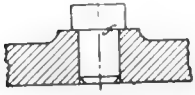

Fig. 2

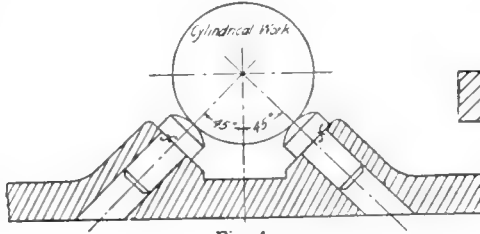

Fig. 4

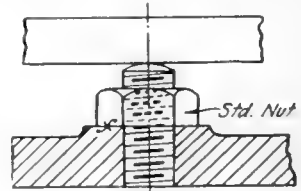

Fig. 5

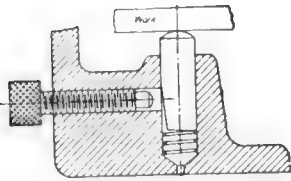

Fig. 3

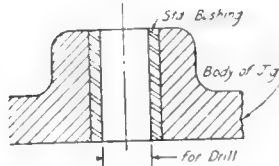

Fig. 7

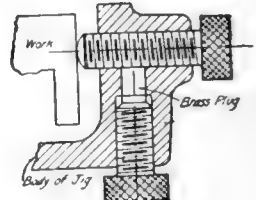

Fig. 6

shop talk, they also come under the listing of tools.

Jigs and fixtures are mechanical contrivances, such that any mechanical or electrical machine part may be placed and held rigidly, during the process of machining. Opinions vary on the exact distinction to be made between the jig and fixture.

Appliances designed for use on a drill press are called jigs, while those designed for use on other machine tools such as millers, planers, etc., are correctly called fixtures.

Jigs may be employed for drilling, reaming, centering, tapping, etc., all these operations being done on the drill-press type of machine. The fixture is used in milling, turning, broaching, boring, chucking, planing, profiling, cam-cutting, gear-cutting, and many other operations in machine shops.

Jigs and fixtures have two distinct advantages—cheapness and interchangeability of parts. When a small number of machines are to be built, the use of

to 75 per cent, due to less "tooling up" than would be necessary with separate parts.

This reduction in cost is attributed to the fact that unskilled, low-priced workmen may be employed to operate these jigs and fixtures with the same amount of accuracy and rapidity that the well-trained, skilful machinist would do. In fact, the unskilled apprentice, with the use of jigs and fixtures, can accomplish more work, proportionately, than the high-priced machinist, who requires a considerable amount of time to set up the work, measuring accurately every dimension called for by the requirements. Without any doubt, jigs and fixtures eliminate brain work and consequently make machine work purely manual labor.

Since cheap labor is used in operating them, jigs and fixtures must be made "fool-proof," that is, they must have no complicated mechanisms unfamiliar to the workman. To be well designed they must not be "trappy." Interchange-



ability of parts is also essential in modern manufacturing. When a machine is standard, any part may be replaced immediately without either filing or fitting.

This is of great significance, where broken parts of the modern industrial, standard machines have to be renewed.

Often these machine parts have to be shipped to remote parts of the world, demanding the necessity of an accurate fitting. Interchangeability is best obtained through the employment of jigs and fixtures, because all parts are held in like manner and distances, thus ensuring mechanical accuracy, which eliminates the unreliability of personal judgment.

Let us consider the location of parts. When a finished surface on a piece of work is used as a means of location, it is best to use steel plates or stool-pins (Fig. 1) for support in the jig. If the locating surfaces are large, they may rest against finished bosses on the jig casting, and then the wear will not be appreciable. A rough casting or forging should rest on three pins as shown in Fig. 2.

If the part is thin or weak, and the tendency is to spring under the thrust of the drill, a spring-pin with a locking-screw may be added for additional support, as shown in Fig. 3. For the location of cylindrical surfaces such as hubs, locating pins set at 45 degrees may be used as shown in Fig. 4. The stops shown in Fig. 4 must be fitted tightly to the jig proper. Sometimes, an adjustable stop may be used as in Fig. 5, thus giving allowance for variation in the casting. These, however, are generally to be avoided as unskilled operators are liable

to tamper with them, resulting in an inefficient jig.

In locating rough castings or drop forgings, care must be taken to avoid resting them on the pins which occur where the molds or dies are parted. Lack of space sometimes prevents the designer from using the spring-pin support, shown in Fig. 3. In place of it, a small jack-screw may be used, as shown in Fig. 6. A locking-screw with a brass plug must be put in, in order to prevent the jack from working loose because of jarring the jig.

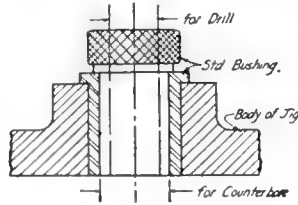

Fig. 8

Bushings are used to guide drills, reamers, counter-bores, etc. They are generally of three types, as shown in Figs. 7 and 8. Bushings must be accurately located in the jig to insure exact duplication of each part. The bushing in Fig. 7 fits tightly while in Fig. 8 are shown both tight and loose bushings.

Clamping is done by means of a standard bolt and nuts, according to the conditions. In Fig. 9 is shown the application of a clamping device. In most cases the location points, themselves, will serve in firmly securing the work, without additional aid.

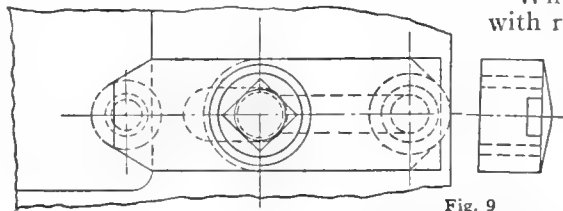
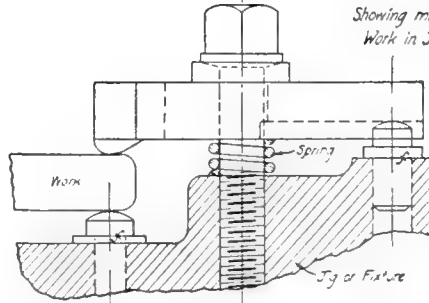

Fig. 9

Showing method of clamping Work in Jig or Fixture



What was said with regard to location and clamping of jigs holds true with fixtures, though the fixture must be built much

heavier, to make allowance for the weight of the cut which is usually heavier. Bushings to be used in the drill jigs are of standard type and can be found in any

standard machinist's handbook. The few principles of design touched on here by no means exhaust the subject.

# A Portable Colony Poultry House

By W. E. Frudden

**T**HIS is a simply built poultry house that will accommodate 30 full-grown birds and the lumber and the roofing material that covers the whole house all told, will not cost over \$30. It is 8 by 10 ft. in size. Runners or skids furnish a foundation for the house.

The skids are 4 by 4-in. pieces and are 11 ft. long. The drawings show where all the pieces go in the house and the photograph shows how the coop looks when it is ready for use. The list of materials tells the exact sizes of the lumber and the amounts of each to buy. The joists are two-by-fours laid across the skids; when set 2 ft. apart, the same spacing is used for all the framework. All the framing lumber is 2 by 4-in. stock. The floor is covered with 6-in. flooring boards, tightly nailed to the joists. The short wall studs are two-by-fours spaced 2 ft. apart, but at the corners they should be double thick. The wall studs are 2½ ft. high with a 2 by 4 capped along the top, to which the roof rafters are spiked.

The side walls and the floor framing work is all done first. When this part is completed start with the roof work. The rafters are cut properly to fit. The roof is at half pitch, using 6-ft. lumber for the rafters. With the framing all done, cover the entire coop with 6-in. flooring lumber, well nailed to the rafters and studding with tight joints. Then the whole coop is covered on the

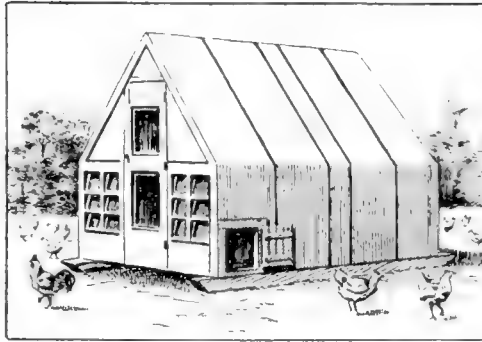

The House will Accommodate Flock of 200 to 300 Chicks or 25 to 30 Full-Grown Fowl

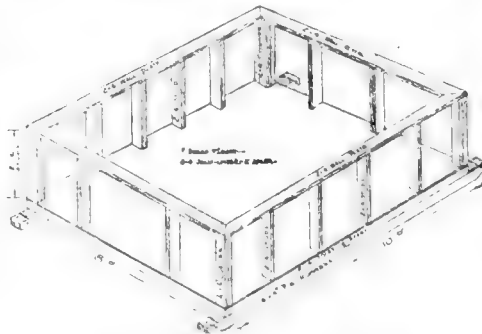

Diagram of the Wall and Floor Framework with Skids for Foundation

outside with a heavy 3-ply roofing paper with cemented joints, put on in the manner described by the manufacturer of the roofing.

The door is screened and muslin-covered for ventilation without drafts, and the glass at both sides of the doorway is built in specially with lapped joints so as to deflect the incoming air upwards towards the ceiling and away from the fowls. Direct air-currents are dangerous in the coop but fresh air is one of the first and most important essentials in coop building in a modern way. Nests are built in along both sides and the roosts

and the dropping boards are located at the rear of the coop. The following material will be needed for this coop:

- 2 pcs. 4 ins. by 4 ins., 11 ft. long for skids or runners
- 2 pcs. 2 ins. by 4 ins., 8 ft. long for floor joists
- 17 pcs. 1 in. by 6 ins., 10 ft. flooring boards
- 20 pcs. 2 ins. by 4 ins., 2½ ft. long for wall studding
- 2 pcs. 2 ins. by 4 ins., 10 ft. long for wall plates (sides)
- 2 pcs. 2 ins. by 4 ins., 8 ft. long for wall plates (ends)
- 12 pcs. 2 ins. by 4 ins., 6 ft. long for roof rafters
- 18 pcs. 1 in. by 6 ins., 10 ft. long for ends and door
- 35 pcs. 1 in. by 6 ins., 10 ft. long for sides and roof
- 3 rolls (100 sq. ft. each) ready-to-lay roofing material
- 12 lights glass, 10 ins. by 14 ins., for front
- 1 cellar sash, 3 lts. 8 ins. by 10 ins., for rear wall
- 1 screen door, 3 hinges and 1 door lock
- 15 pounds nails
- 20 sq. ft. wire mesh screen

How to Drill Holes Quickly in Wood

WHEN drilling holes in wood to a predetermined depth, a metal fiber or other tube of the correct length, placed over the bit as shown in drawing, will make it possible to do this part of the



A Tube of Metal Fiber Placed Over the Bit Accelerates the Job

work with a great deal more speed and accuracy than is usually attained by amateurs at the work.—WALTER FRANSEEN.

A Screen Door-Check

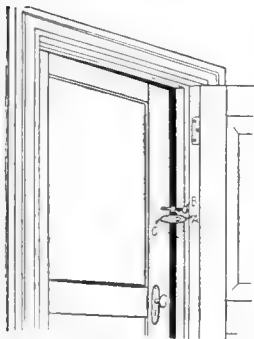

A Rubber Button and Small Bolt Are Required

ALTHOUGH a screen door is a summer necessity, it is also a frequent source of annoyance because of its tendency to slam. A pneumatic door-check overcomes the slamming but allows the door to remain open long enough to admit flies. The door-check described, consisting of a rub-

ber button and a small bolt, obviates both difficulties.

The bolt should have a head about  $\frac{3}{4}$  in. in diameter, and a shank about 3 ins. long and  $\frac{1}{4}$  in. in diameter. It is screwed or driven into the inner face of the door near enough to the outside edge to clear the jamb when the door is closed.

The button is a boat-shaped piece of rubber a trifle longer than the bolt. It is attached to the jamb by a screw  $\frac{1}{4}$  of the way from the top of the button. It swings loosely on this screw and hangs by its own weight, as in the illustration, where the door is pictured ajar showing clearly the mechanism.

When the door closes, the projecting head of the bolt, *B*, comes first in contact with *A*, the upper end of the button. As the head of the bolt passes, it swings the button out [as indicated by dotted

line. The lower end of the button, *C*, thus comes in contact with the face of the door before the door touches the jamb.

The blow is consequently checked by the rubber and the door closes quickly and without noise. The button drops back into place again ready for the next comer.—E. P. THORNTON.

Cooling a Ship's Laundry

A SHIP'S laundry is a hot place—not the only one, of course, and not the most confining one. Besides there are ways of making this one considerably more comfortable.

Some of the resourceful sailors on board the U. S. S. Maryland who objected to this particular hot place got relief as follows: Several sheets of galvanized iron were cut and bent as shown in the drawing. Two small straps were made to go with each sheet. Holes were punched for small stove bolts, and the fans were attached to the overhead shafting, as shown.

This scheme for improvising fans when shafting is in operation, could be used in many other situations. The bolts should clamp the shaft tightly to prevent slipping.—A. and P. THOMPSON.

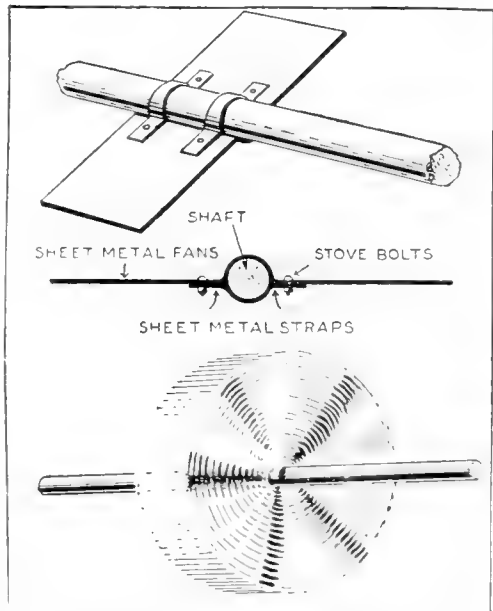

Improved Electric Fan at Rest and in Operation

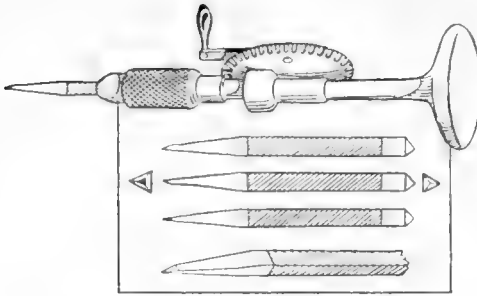

Diagram of a Drill About 3 Inches in Length for Drilling Plate-Glass

### Making a Plate-Glass Drill

THE accompanying diagram shows a drill about 3 ins. in length for the drilling of plate-glass. It can be made from an old corner-file. It allows for the drilling of any size hole, which depends on the size of file and the length and size of taper.

The piece of file is ground down along its side on a taper until a point concentric with sides of the file is obtained. The point should then be cut off obliquely, as shown in the illustration. It is then ready for use. Drills of this kind can be used for many years with satisfactory results.—JOHN HAVEKOST.

### Coloring of Copper

COPPER and brass lend themselves readily to a coloring process and may be worked to all shades and hues imaginable by merely oxidizing the surface of the metal. Make a paste of iron oxide and graphite with wood alcohol or with plain water, and apply this to the article, which is then heated in an oven or over a suitable gas flame. It is better to use alcohol as it dries out much quicker. The color obtained will depend on the amount of iron oxide mixed with the graphite and the length of time that the heat was maintained. The more oxide in the coating the darker the shade will be. The remains of the coating should be removed with a brush or cloth moistened in alcohol, and when the surface has become quite clean the color should be protected by applying varnish, lacquer or pure wax, which may be laid on with a brush while the copper is heated.

Some brown colors are obtained by

using a mixture of verdigris, sal ammoniac and vinegar, using two or three times as much verdigris and sal ammoniac as vinegar. The color or shade can be rendered much darker by adding some blue vitriol to the solution. A red brown may be given by using a vinegar paste, containing equal parts of verdigris and cinnabar, together with two and one-half times as much each of sal ammoniac and alum. The heat treatment is the same as for the other coatings. A wide range of colors comprising shades from blue-black to blue-gray may be given to the copper by dipping it in a hot "liver of sulphur" solution, then washing thoroughly, re-dipping, or scratch-brushing, and again dipping and washing if desired.

### A Handy Spacing Scheme

THE drawing illustrates a handy scheme for drawing parallel lines spaced accurately at equal distances.

Take a strip of ruled paper and fasten it wherever you choose on the drawing-board. The ruled lines on the strip are used for guides either for the T-square or for triangles. The strip may be fastened vertically on the board, horizontally, or at any angle.

In case of absence of ruled quadrangle paper, advertisement borders do very well. I have used the "spaced variety" of advertisement border successfully many times. It will be found in various spacings.—N. G. NEAR.

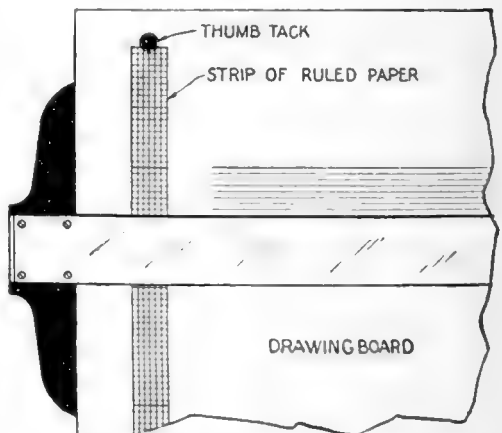

Ruled Lines on the Strip Are Used for Guides for T-square or Triangles

# A Cozy Southern Farmhouse



With the House Facing South, the Living-room and Bedrooms Will Have the Advantage of the Prevailing Summer Breezes

**A**FTER extensive surveys in the South to determine the household needs of families with reference to local agriculture, climate, and domestic help, the Office of Public Roads and Rural Engineering of the Department of Agriculture has developed a plan for a southern farmhouse which meets all the requirements of a small family. The materials selected are those commonly used in the South, and local dealers should have no difficulty in carrying out the plans.

The aim primarily is to provide a cool and convenient kitchen and dining-room for the housewife; bedrooms and living room with the best exposure; facilities for outdoor sleeping, and an easily-heated house, cool in summer and yet with sunny rooms in winter.

With the house facing south, the living room and bedrooms will have the advantage of the prevailing summer winds, which, generally throughout the South, are from the south or southwest. Where the prevailing winds vary from the usual direction the plan can be reversed if desired, or the house so placed that it will have the proper relation to the summer breezes.

The arrangement of dining-room and kitchen constitutes the chief feature of the plan. The china closet, opening into

both rooms, saves a great many steps between the kitchen and the dining-room. The clearing up after meals can be accomplished with a very few steps, dishes being passed through on the wide counter shelf, washed at the sink, drained, and returned to the china closet, where they are available from either side.

The kitchen is small, well-lighted, conveniently arranged, and cool, by reason of the facts that the range is in a separate room and the windows on opposite sides permit a cross draft. The distance from the range to the other fixtures is no greater than in most farm kitchens; and, if it were, the extra step or two would not offset the marked advantage of coolness of the workroom where the greater part of the kitchen work is done. This is a matter of considerable moment, since so many farm wives in the South are now doing their own housework.

The cook-room ceiling has a large opening which permits the heat and cooking odors to escape through a ventilator in the gable. Near the stove, to give light and air, is a double casement window. A grated opening near the floor, in the wall between the cook-room and the kitchen closet, draws air from below the floor and promotes circulation

from the floor upward and helps to keep the lower part of the room cool.

In winter, if it is desired to keep the heat in the house, the door between the cook-room and the kitchen can be kept open and the ventilator and grating closed when not needed to carry off odors. The separate and well-ventilated cook-room will insure a dining-room which is cool and free from odors. The fuel-room, filled from outside, is right at hand, obviating the necessity of carrying in fuel every day.

The bathroom is readily accessible from all parts of the house, and can be used for washing up by the men in the family coming from barn or fields without going through other rooms. The closet on the rear gallery is intended for boots, rubber coats, etc. As this house was designed to meet conditions prevailing in the South, no provision was made for a washing room for the farmhands, who, as a rule, have their own quarters.

Instead of open fireplaces for heating purposes, the drawings for this house provide for a hot-air furnace installed in a pit beneath the bathroom. The cost of installation would not greatly exceed that of the two chimneys, with two open fireplaces each, which would be necessary to heat all the rooms. The upkeep would be less and the efficiency and comfort far in excess of that afforded by open fireplaces. If the situation is low, with water near the surface, the house can be raised higher from the ground and the pit carried down but 3 ft. or so. It should be built of concrete and made waterproof. Space for fuel storage is provided under the rear gallery, and there is a vegetable cellar under the kitchen.

There is less front gallery to this house than in most southern farmhouses. The reason for this is that, while galleries add to the coolness of a house in summer, they keep the winter sun out, making the house damp, cold, and cheerless.

Extensive galleries add to the house-keeper's work. If a house has wide eaves and good roof ventilation and is placed so that it is partly shaded by trees, the same beneficial effect afforded by galleries is had in the summertime, while in winter the sun will penetrate each room at some time of the day. The summer temperature within a house is largely influenced by the presence of near-by trees, which, even if they do not shade the building, prevent or lessen radiation from the ground. The plan, however, does provide a comfortable front gallery, and the sleeping porch can also be used as an outside sitting room. Two sleeping compartments can be provided on this porch by using a movable partition or screen.

The sleeping porch should be screened in for summer use and glassed in during the winter, at least on the side most exposed to cold winds and stormy weather. Canvas curtains on rollers to enclose the sides during a storm will answer the same purpose. The floor should be laid with narrow spruce boards, using white lead and oil to fill in the cracks.

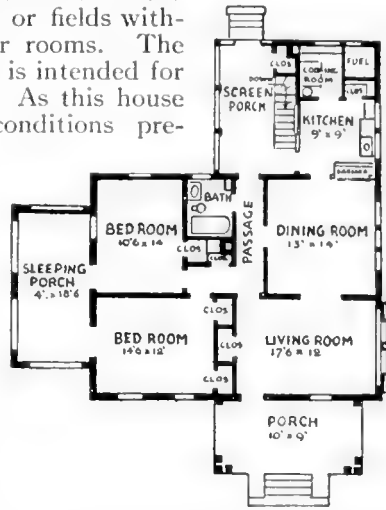

Storage for Fuel Is Provided Under the Rear Gallery and a Vegetable Cellar Is Under the Kitchen

#### To Improve Machinist's Cement

**T**HE red lead used in machinist's cement may be diluted with an equal bulk of silica or other inert substance to make it less powdery on drying. The best way to avoid brittleness and dryness, however, is to add rubber to the oil according to the following recipe:

Linseed oil . . . . . 6 parts by weight  
Rubber or gutta-percha . . . . . 1 part by weight

Dissolve the rubber or gutta-percha in sufficient carbon disulphide to give it the consistency of molasses; mix with oil, and leave exposed to the air for about 24 hours. Then mix the oil thus prepared with the red lead to form a putty.

# Money Prizes for Motorcyclists

## Send Us Your Kinks

**I**F you are a motorcyclist, if you have devised simple ways of making repairs, if you have improved your machine in any way, this will interest you.

The POPULAR SCIENCE MONTHLY offers a first prize of \$25, a second prize of \$15 and a third prize of \$10 for articles in which motorcyclists will describe and illustrate the methods which they have successfully employed for overcoming trouble, for making quick repairs by the roadside or more difficult repairs in the shop, or for making attachments whereby the use of the motorcycle has been broadened.

### Even Though You Don't Win a Prize It's Worth While

The three prizes will be awarded by the editors of the POPULAR SCIENCE MONTHLY in the order of merit. What is more, even though your article may not win a prize, the editors may buy it at the usual rates, because it is so good.



A grease-gun made by twisting a piece of paper into a cone. Hard grease is placed in the cone and simply squeezed out through the small end whenever it is wanted

There are no limitations to this prize offer. We don't care for fine phrasing, but we do care for good mechanical ideas. Rough pencil drawings or photographs will do for illustrations.

### Here's What We Want

To give you an idea of the kind of material that will be welcomed, consider the two ideas illustrated on this page. The sidecar illustrated was made from one wheel of an old bicycle, some boards and bar-iron. The grease-gun is merely a cone of paper which is filled with hard grease out of which the lubricant can be squeezed as it is wanted.



This sidecar was made out of one wheel of an old bicycle, a few boards and some bar-iron

### Follow These Rules

The following conditions are to be observed:

- (1) Articles must be written on one side of the sheet only.
- (2) Write your name and address in the upper right-hand corner of the first sheet.
- (3) Enclose postage for the return of the manuscript.
- (4) Don't send in articles on ideas which have already been published.
- (5) Don't send paper ideas—things that you haven't actually done yourself.
- (6) Address the envelopes containing articles to

### “Motorcycle Contest Editor”

POPULAR SCIENCE MONTHLY  
239 Fourth Ave., New York City

The contest will close on December 31st, 1916.

The money for the prizes will be paid promptly after the awards have been made.





An outfit for photographing animals from the bow of the boat. A wooden revolving camera bed, large enough to carry two cameras, is secured to a ball bearing support which is rigid, absolutely noiseless and enables the camera to be swung through an angle of one hundred and eighty degrees. When the lantern shines on the animal the flash powder may be fired, provided the distance is correct. If desired, one lamp may be fired after the other successively, to show the animal in different positions. This requires two firing lines and two cameras

# Popular Science Monthly

239 Fourth Ave., New York

Vol. 89  
No. 4

October, 1916

\$1.50  
Annually

---

---

## Wild Animals That Photograph Themselves

**P**HOTOGRAPHING by flashlight is one of the more recent advancements in the field of picture-taking which has helped to secure for photography a permanent place among the arts. Paul J. Rainey, the explorer and hunter of wild animals, proved several years ago at the first exhibition of his wild animal flashlight pictures taken in Africa, that this class of photography offered a virgin field to the manufacturer of apparatus and to the man behind the camera. Soon after this there was an awakened interest in animal film shooting in preference to gun or trapshooting.

At the present time photographic flashlight apparatus has been developed to a point where guesswork is eliminated and where it is possible to photograph any object in motion. To do this it is necessary for the camera to catch the object in motion just at the instant when the flash powder is giving forth its brightest light. This requirement calls for a high-speed shutter to stop the motion on the plate of the object being photographed. With a flashlamp recently perfected by William Nesbit the shutter is automatically snapped at exactly the moment when the light from the flash powder is most intense. His apparatus has been widely used to take flashlights of wild animals in their native haunts and has given uniformly good results.

When flash powder is ignited it does not burn up or explode instantly, as might be supposed. It burns more and more brightly until it reaches its point of greatest brightness, from which point on it dies down until it goes out. This

whole operation takes at the most one fifth of a second. However, good pictures will be obtained only if the camera is snapped during this fifth of a second, when the flash powder burns the brightest.

On the other hand, this point can never be definitely determined before taking the picture. It changes for different powders and also varies for the same powder, since the powder may become slightly damp and will not burn in the same way. It is evident, then, that to snap the camera at precisely the right moment is not so easy as it might appear.

The flashlamp devised by Mr. Nesbit consists of an aluminum container to hold the flash powder, a cover for this container, a mechanism to fire the powder, and an attachment which will automatically snap the shutter of the camera at the moment when the flash powder is burning brightest. The unit is waterproof, and so compact that it can be readily attached to a tree or other convenient support.

The flash powder is placed in a box made waterproof by a coat of paraffin and is then placed in the space provided for it in the flashlamp. The powder is fired either by a blank cartridge or by an electric spark furnished by a dry battery. A firing-pin, controlled by a spring and a trigger, similar to those used in a rifle or revolver, sets off the cartridge.

When taking a flashlight of an animal, a wire is attached to the trigger and then tied to bait of some sort. The animal is attracted by the bait, and if it touches it, the wire is pulled, which, in turn,

pulls the trigger, releases the firing-pin and ignites the powder by exploding the blank cartridge. When the powder is to be ignited electrically, a wire is stretched from a switch to the bait. Once the bait is touched a circuit is closed and an electric spark sets off the powder.

The shutter on the camera designed by Mr. Nesbit is operated by means of the cover placed over the container holding the powder. This cover is attached to a chain

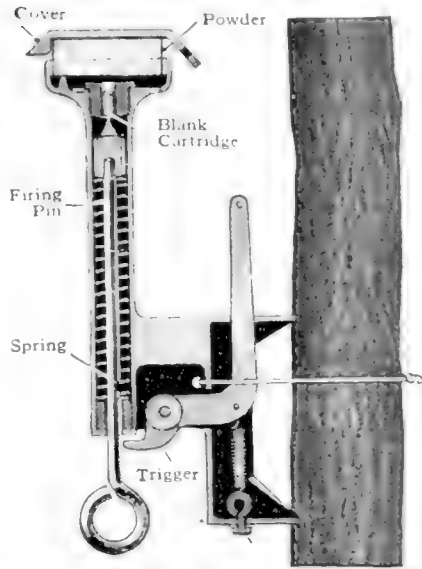

be found. The cover is so arranged that it cannot be blown off until the powder is burning with its greatest brightness.

When the wire to the bait is pulled, the powder is ignited and commences to burn. For a small fraction of a second the cover remains in place while the powder burns. Then, when the powder is burning with greatest vigor and is giving off its brightest light, the cover is blown off and the shutter of the camera is snapped.

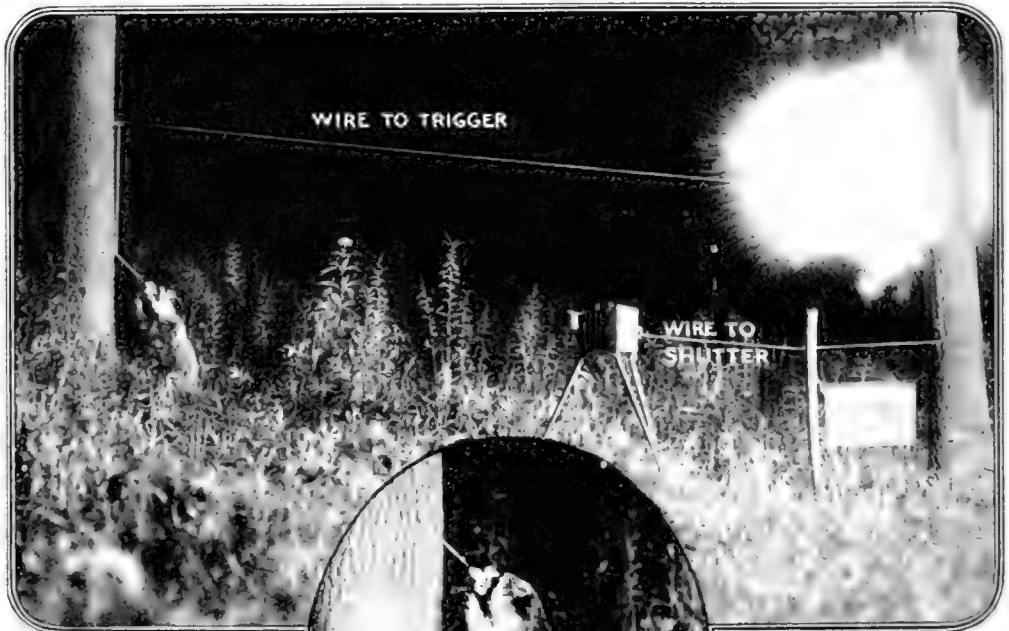

Below, the animal attracted to the bait, which is attached to a trigger which releases the firing-pin

which is fastened to a tree or post supporting the lamp. This is to prevent the explosion of the powder from blowing the cover so far away that it cannot

The wiring arrangement, showing the flash occurring at the very instant the bait is touched by the animal

Sometimes two sets of cameras and flash-lamps are used to give two pictures of the same animal in different positions, before and after his fright.

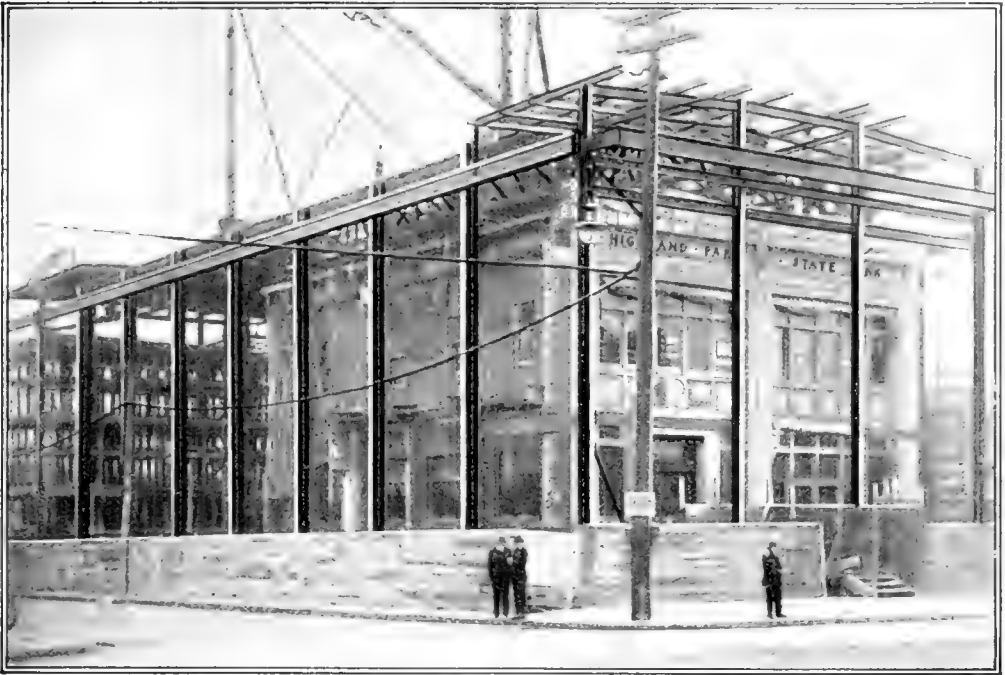

Instead of closing its doors or moving while its building was being enlarged, this bank staid where it was and had a new structure built around the old without the least interruption

### Building a Bank Around a Bank Without Disturbing Business

**A** DETROIT bank recently found that so much money was coming in that there was not enough room to store it. Instead of closing the doors and shutting off this desirable influx of dollars, the bankers decided to build a new home for their dollars outside of the old one.

Accordingly, banking hours remained the same. As the old building was torn down, part by part, new offices were opened in the growing outer structure. There was no interruption. The new building has three times the capacity of the old one.

### Steel Cutlery Which Will Not Rust Under Any Circumstances

**T**HE housewife can now cease to worry about tarnished or rusted knives, forks, etc. A new steel has appeared from which cutlery is being made which not only takes a beautiful polish

but which preserves this appearance under all circumstances. It neither rusts nor tarnishes in contact with foods or acids and its use is making great headway. To be able to use a knife or fork and to have it maintain its original brightness by simply washing it is a boon to the housekeeper.

The new steel composition was invented in England and is what is commonly known as an alloy steel. It is not a high carbon steel for it averages only 0.25 to 0.35 per cent carbon but the ingredient which bestows on it its unusual properties is chromium, a chemical element or metal similar to nickel. By incorporating from 12 to 13 per cent chromium in mild carbon steel, the new stainless properties are bestowed upon the manufactured product.

The new steel is more expensive than that formerly used in making steel cutlery but its lasting properties as well as its appearance and convenience more than offset this extra cost. Its possibilities are not limited to cutlery.

Those of us interested in science, engineering, invention form a kind of guild. We should help one another. The editor of *THE POPULAR SCIENCE MONTHLY* is willing to answer questions.

### A Mechanical Masseur That Works Off Fat and Soothes the Nerves

"VANITY of vanities—all is vanity," saith the preacher; but the desire for a svelte figure may not be altogether vain. Excessive weight may mean faulty elimination of waste and underweight may mean nervous tension, so that both are to be avoided. It should be a source of satisfaction to discover a means of acquiring a fine, symmetrical form and physical fitness at the same time without entailing loss of time or any long-drawn-out course of exercising.

The automatic massaging machine illustrated here has been designed with that end in view. It is scientific in principle and is composed of a double circle or belt of forty-eight roller-wheels hung on oscillating frames four

inches apart. This belt encircles the body, the upper left-hand roller in each frame overlapping the lower right-hand roller in the next frame, so that as the frame expands in passing from the smaller to the larger portions of the body the rollers still pass over the entire surface of the skin.

An elastic belt between the two rows of rollers gives equal pressure to each roller, regardless of what position the frame takes in traveling over the irregular surfaces of the body. Thus the hollows receive the same pressure and stimulation of circulation as the higher portions. This pressure can be increased, diminished or shut off instantly simply by pushing a button. The rollers can be set to travel from the knees to the neck or the stroke can be shortened to any length and massage applied exclusively to any part desired.

The machine weighs two hundred and thirty-five pounds and is equipped with a one-sixth-horsepower motor for any current. A substantial iron base is provided which eliminates vibration when the machine is in action.

### Taking a Census of Occupational Diseases

A STUDY of the subject of occupational diseases affords abundant surprises. Housemaid's knee, for instance, which for many years has served as a subject for humorous comment, proves to be a frequent malady of miners. Dust has been found to contain not only minute particles but a watery envelope surrounding the particles. Sawing certain kinds of woods is said to produce irritation of the mucous membranes of the

nose, throat and eyes. Chimney-sweeps are especially subject to cancer because soot gets into the system.

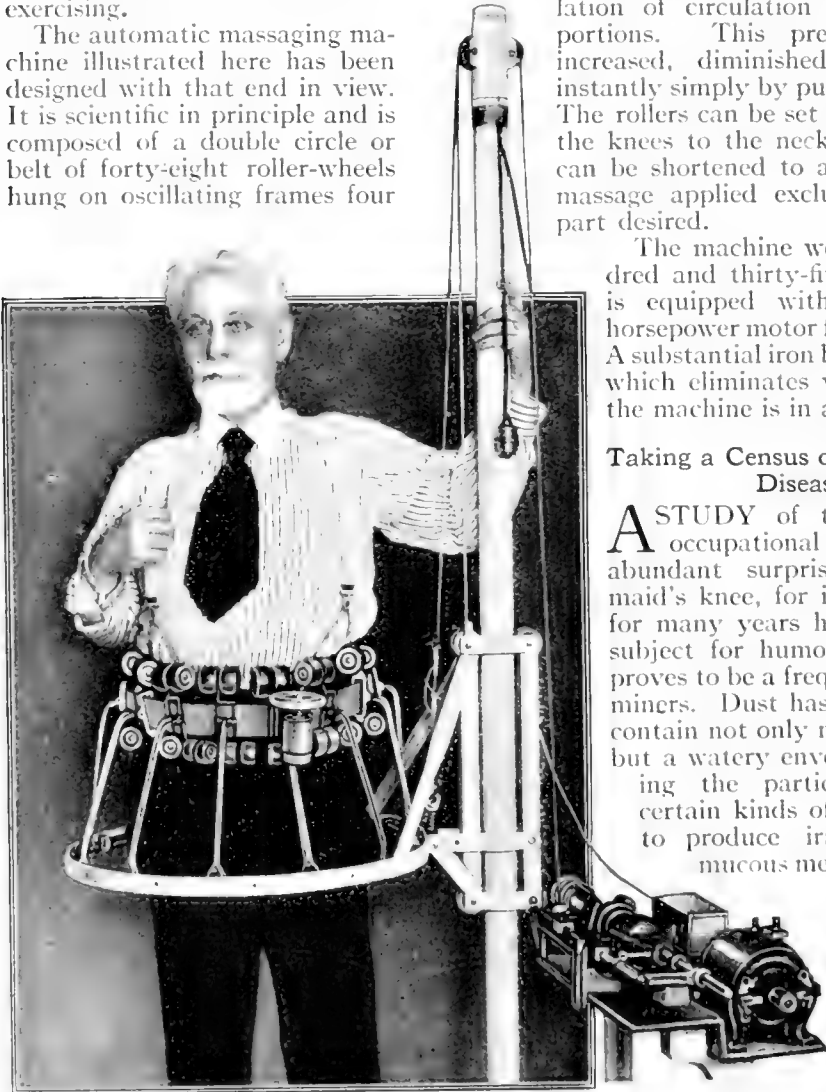

Forty-eight roller-wheels hung on oscillating frames travel over the body from the knees to the neck and the pressure can be increased at will

# Transporting the Wounded Man in Comfort



Photos © Int. Film Soc.

Above, an aerial cableway for the transportation of wounded soldiers in the Alps. The wounded man on his stretcher is placed on the cableway-car and transported to the hospital base above or below him



Above, a basket arrangement of seats, one on each side of the horse, accommodates two wounded soldiers

A dog ambulance with inflated tires and light springs which insures a comfortable ride



Photos © Int. Film Soc.

# Bird's-Eye View of an Aviation Camp Near the



© Underwood and Underwood, N. Y.

A remarkable photograph of a French aviation camp near Verdun. The picture was taken by a French aviator at an elevation of 1800 feet directly over the camp. The huge tent-like structures are aeroplane hangars and in front of them are stretched eighteen flying ma-



# Great Battlefield of Verdun Made from an Aeroplane



chines. Grouped about the hangars are motor-trucks and cars. To the left are the tents which constitute the homes of the aviators, pilots and others stationed at the camp. The white streak diagonally across the photograph is a road. To the right are farm lands

# With the Fighting Legions in France



Underwood and Underwood, N.Y.

Above, an instance of where a crater made by a shell from the enemy works to the advantage of the troops under fire. It affords them protection as an impromptu breastworks

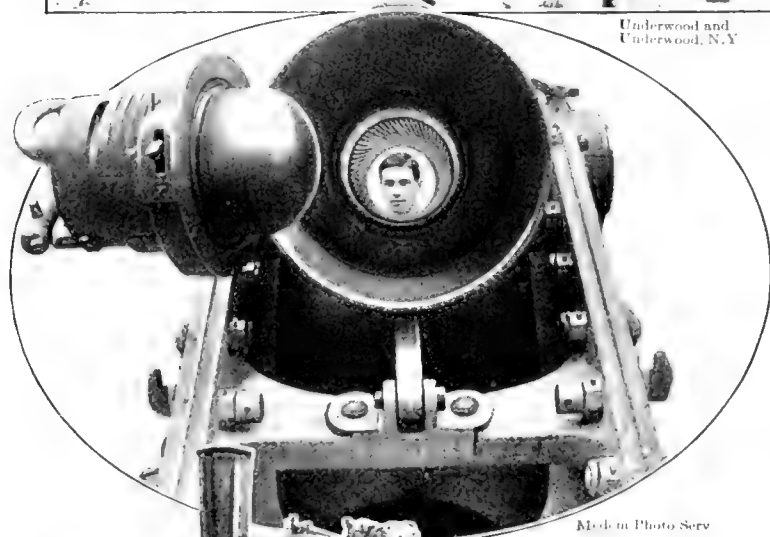

Mack in Photo Serv

At left, the business end of a field gun affords a natural frame for a portrait. No official stamp is necessary to prove that this is a war photograph taken at the front (of the gun)

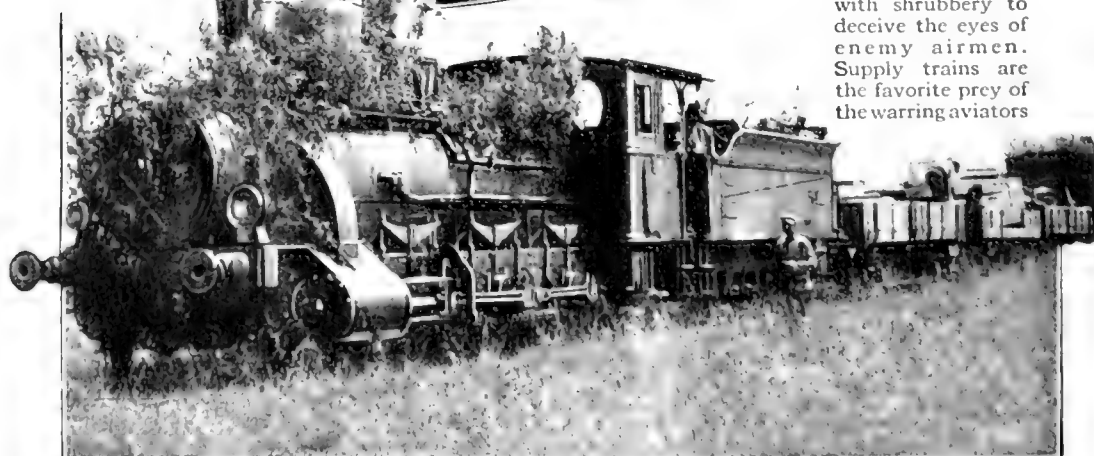

Below, a train of supplies on its way to the front adorned with shrubbery to deceive the eyes of enemy airmen. Supply trains are the favorite prey of the warring aviators

# Sowing Fifteen-Inch Seeds with the Big Guns

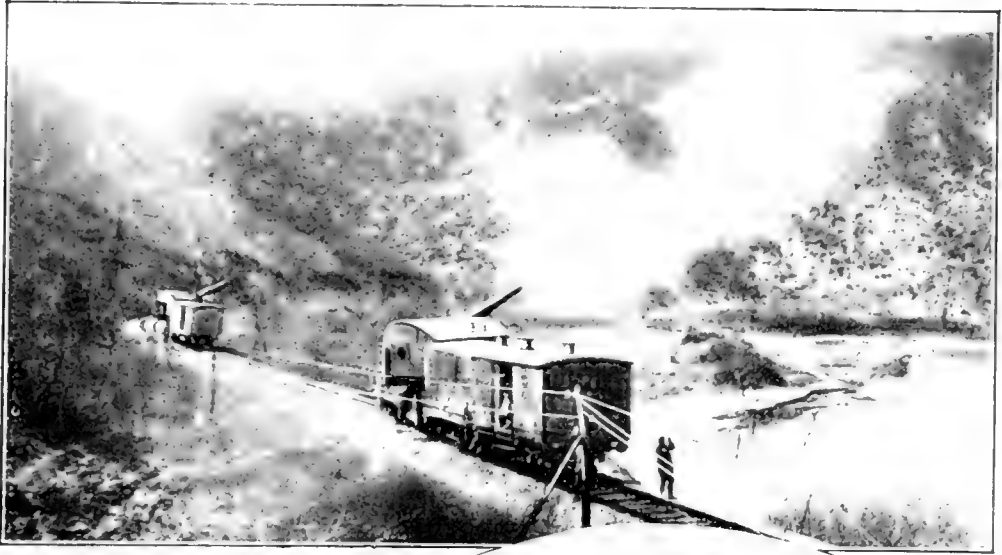

Modern Photo Serv.

Armored trains moving on the enemy in the Vosges. The guns are mounted on turntables which enable them to operate over a circumference of one hundred and eighty degrees. At right, a hole made by a German aerial torpedo in territory held by the British on the western front. Nothing, human or otherwise, can withstand these immense torpedoes

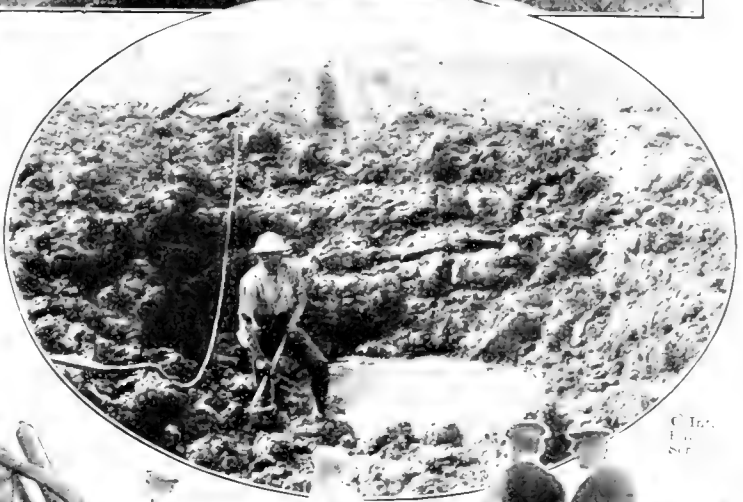

© Int. Photo Serv.

An English monster mounted on a railroad truck on its way to the Somme district to pulverize concrete trenches and batter back the invading enemy

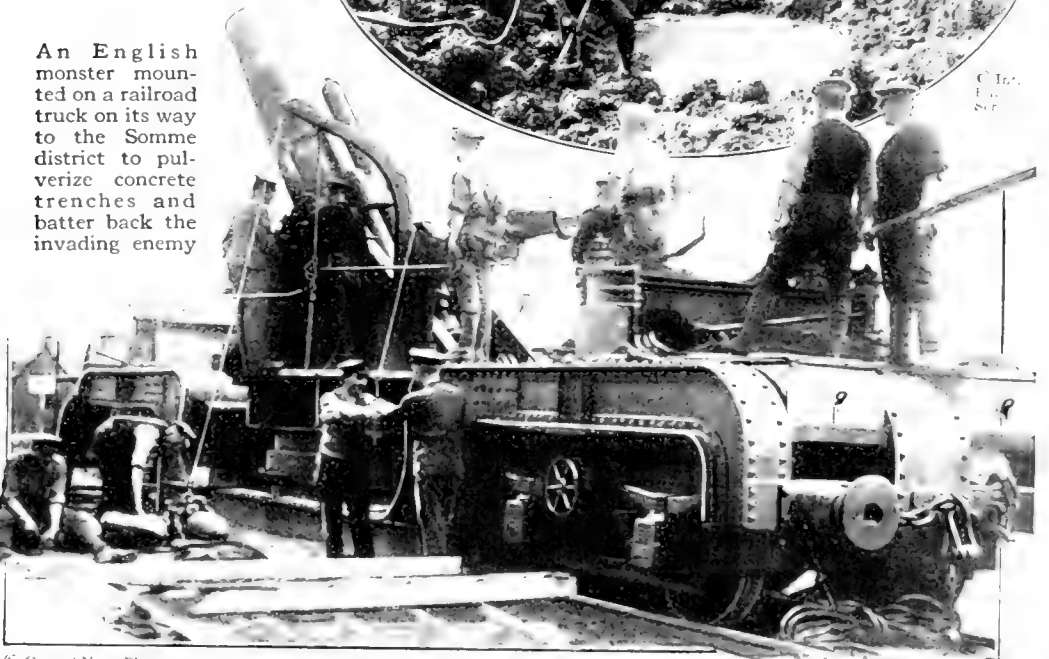

© Central News Photo Serv.

# Ammunition to Blaze the Way at Verdun

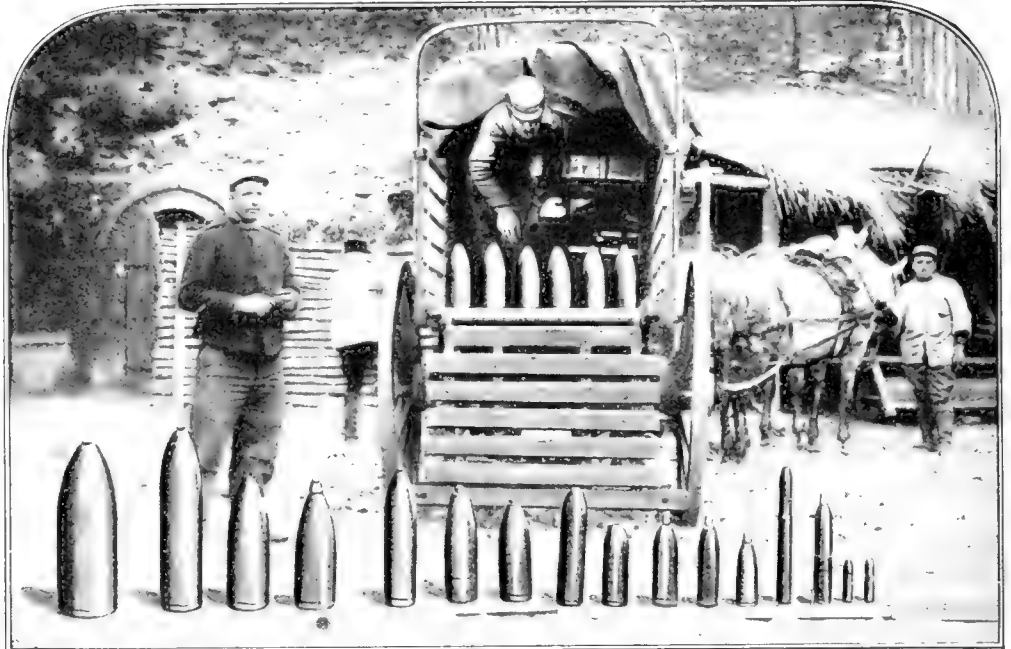

© Modern Photo Serv.

A collection of different-caliber shells which gives a vivid illustration of the variety of ammunition used in modern warfare. Each shell is specifically designed for a certain purpose, even though they are all meant for man-killing. The little fellows pick out a single man for their target; the big ones choose a whole company, fort or locality for theirs

Below, a depot of big-caliber shells which have helped in their way to make Verdun a five month's nightmare. These shells are stored in the rear of the fighting lines and are taken to the front as they are needed. Powerful motor-trucks distribute them to the armies



© Universal Press Syndicate

# The Stuff That Modern Victories Are Made Of

© Int. Film Serv.



Above, a heap of trench-mortar ammunition behind the lines of the British troops on the western front. These round, buoy-like shells are fired from trench-guns into the trenches of the enemy, where they explode with terrific force. Below, shells stacked like cordwood ready for transporting



A French trench with a barbed-wire fence protecting it from intruders. A door leads through the wire barricade and beside it stands a sentry, ready to interrogate everyone who approaches



# Pets and the Gentler Side of the Fighter



At left, a fawn left by its frightened mother in the friendly hands of German soldiers. This little animal was adopted as the troop company's mascot and given a home in the trenches, where it was sheltered from shots and shells



At right, a British soldier with a little king of the beasts as his pet. Will it be a bodyguard such as that of St. Geronimus?

At right: Raising chickens while the enemy is raising siege guns for action is rather soothing for the fighting man, besides the luxury of the fresh eggs for breakfast



Photos © Central News Photo Serv



At left, the dog they left behind makes his home with the soldiers, and gets better treatment than he would if there had been no war

At right, rabbits are as friendly as they are prolific. They are perfectly at home in the trenches



# Restoring the Hearing of Deafened French Soldiers

Dr. Marage, a well known French physician, has been asked by the French Minister of War to treat soldiers who have been deafened by the explosions of shells and grenades. To the right, Dr. Marage is shown examining a soldier to determine the extent of his injuries, the first step toward the restoration of his hearing

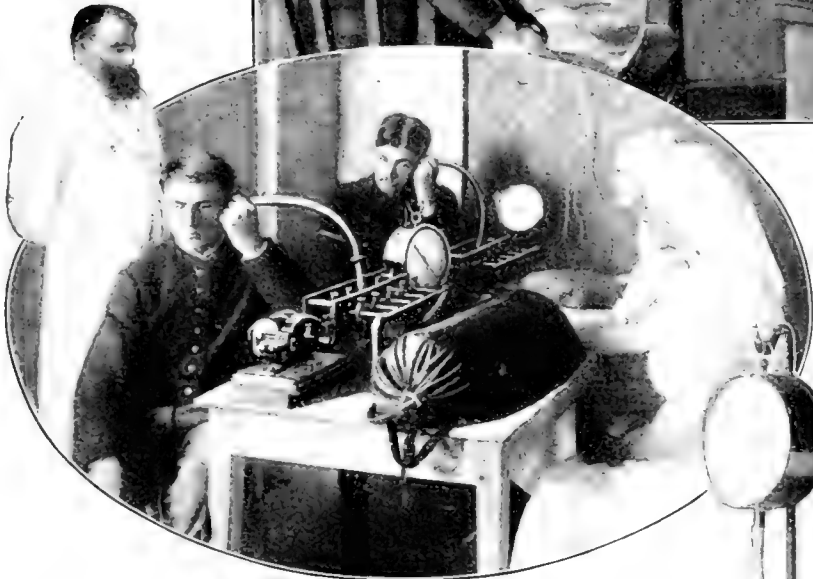

As shown at the left, Dr. Marage treats deaf soldiers by making them listen to the sounds uttered by a vowel-pro-nouncing machine of his own invention. The vowels are uttered with an intensity, duration and quality determined by the bag of compressed air in the foreground

Below, Dr. Marage's apparatus for treating deafened soldiers. It is a mechanical mouth for uttering vowel sounds. The inner ear is massaged by sound vibrations for about two weeks. No less than sixty-eight per cent of the soldiers treated are able to rejoin their regiments

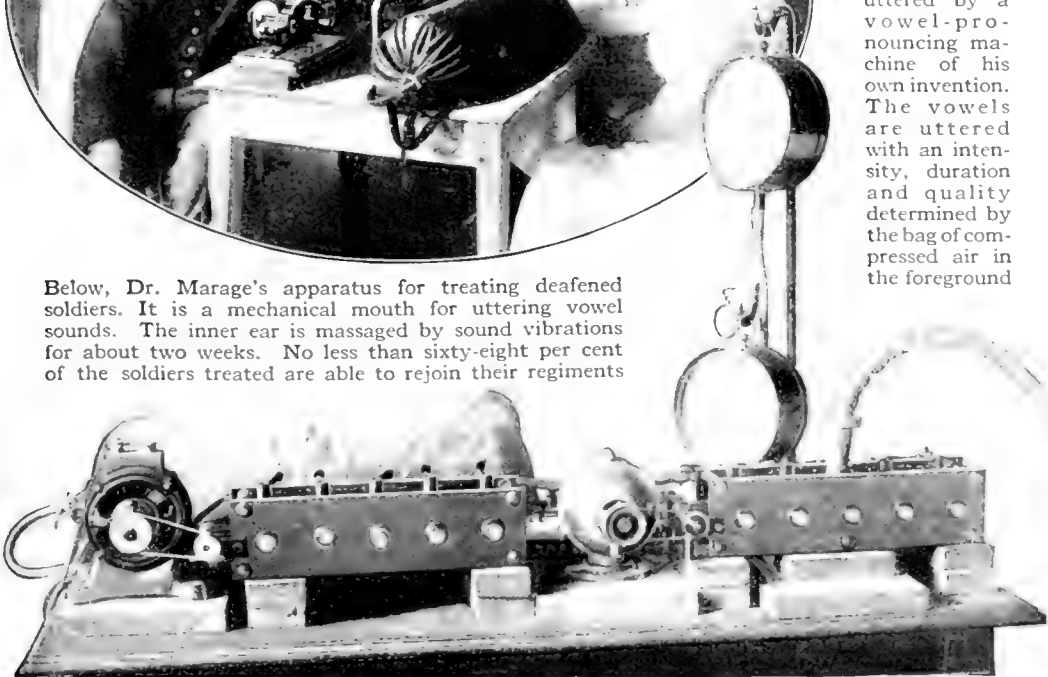



# Insect Grotesques Which Assume Frightful

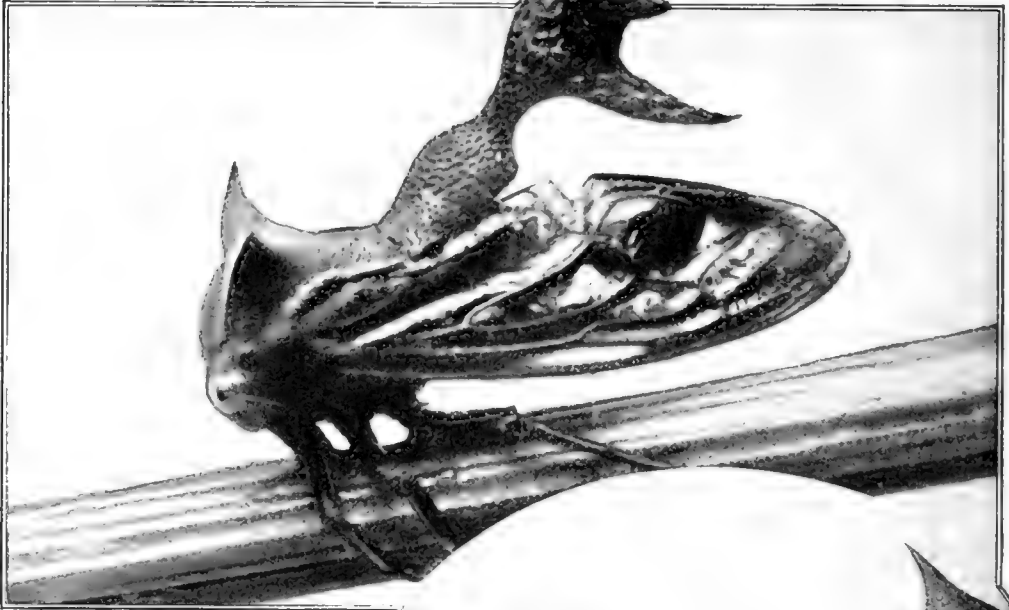

Above, a good instance of the grotesqueness of many of the living insects which make up the Membracidae, of which more than eight hundred species have been found

At right, the well-known Brazilian "thorn-bug," one of the insects, which looks exactly like a big thorn when it is at rest. Its shell is hard and the protruding points are sharp

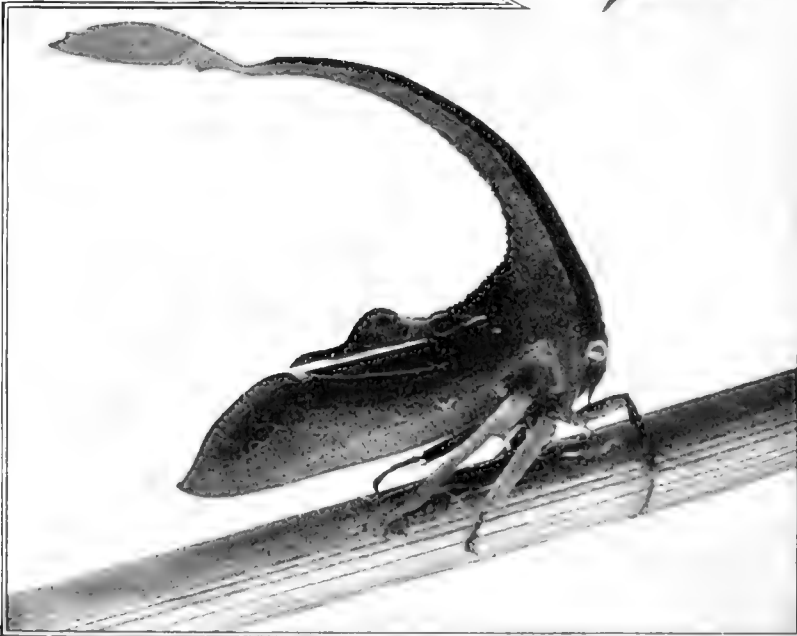

Another quaint Membracid. The use, if any, of the strange extension of the prothorax is unknown. It is part of the "back-plate" that Nature has worked upon to produce the varied and wonderful forms for which these insects are so remarkable

# and Imitative Forms as a Means of Self-Protection

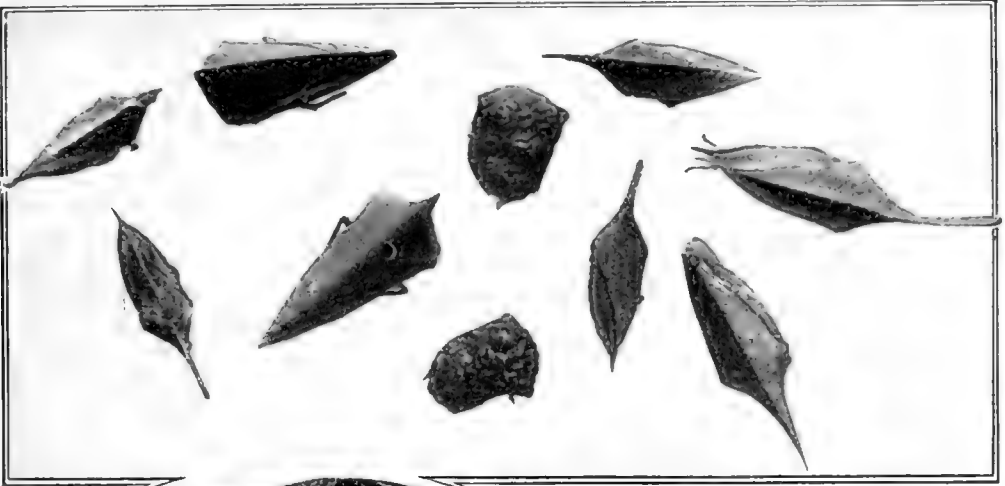

Above, a number of seed-like Membracidae from tropical South America. They are probably overlooked by all but the most astute insect-eating birds in search of a meal

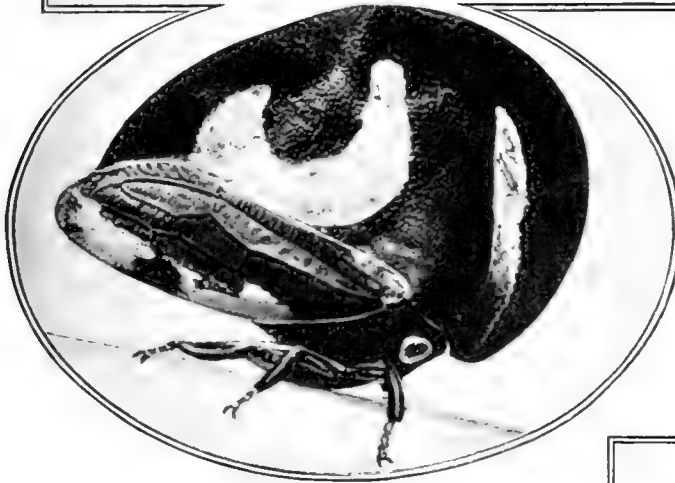

At left, an extraordinary insect with a huge, helmet-like expansion of the prothorax. This is so large in some insects that they are completely covered by it

Below, a strange looking insect which, when alive, looks as if it were being attacked by a spider. This is really the insect's armor plate

At right: The apparent body and formidable sting of this insect are a mere pretense, being only a horny outgrowth from the thorax

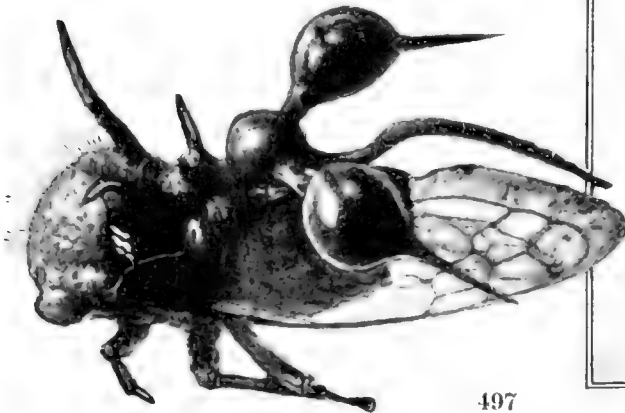

## When Nature Plays the Architect of Bridges

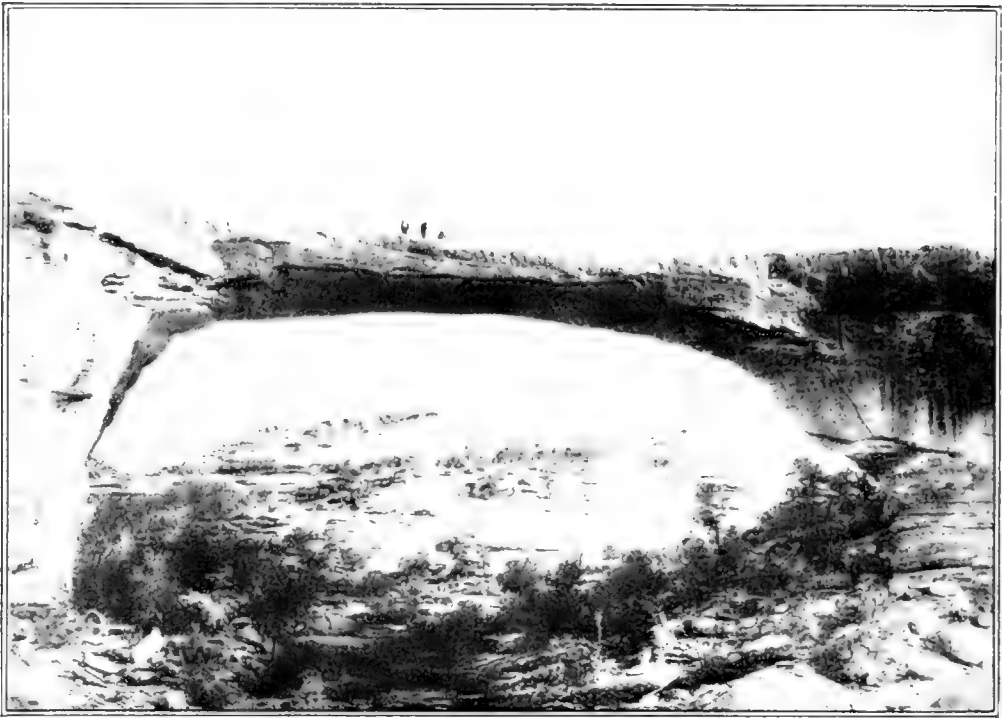

The Nonnezoshe, or Rainbow arch, shown above, has been carved by the elements from the brick-red sandstone of southeastern Utah. The Navajo Indians called it the Sun-Path and beneath it are ruins of an ancient altar doubtless built by superstitious cliff-dwellers

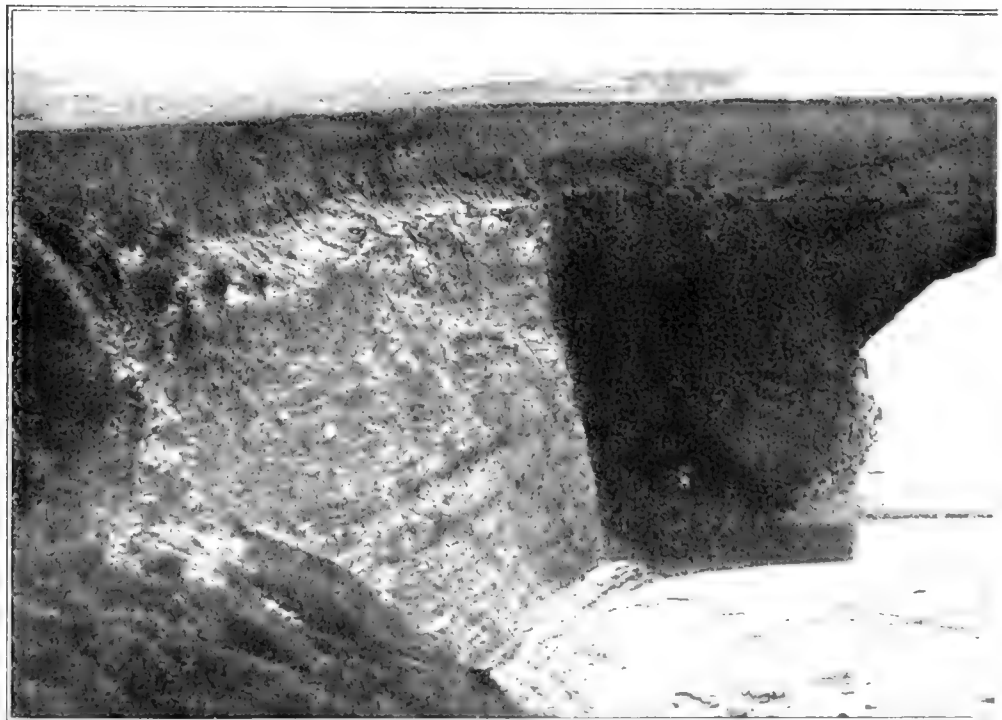

# Her Tools Are the Elements and World-Old Rock

Notwithstanding the fact that the Owachomo Bridge in southwestern Utah, shown on the right, is called the "Little Bridge," it is one hundred and six feet high and nearly two hundred feet wide

The natural bridge of Santa Cruz, California, shown in the picture extending across both pages below, arches a perfect causeway, which has been formed by the inrush and outwash of waves during many centuries

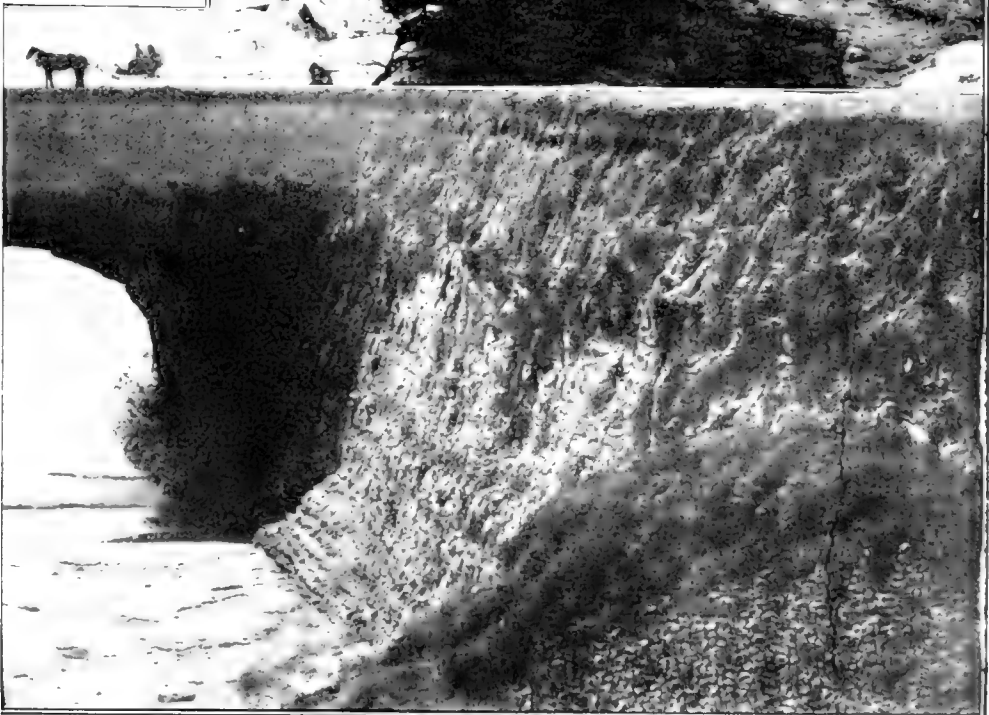
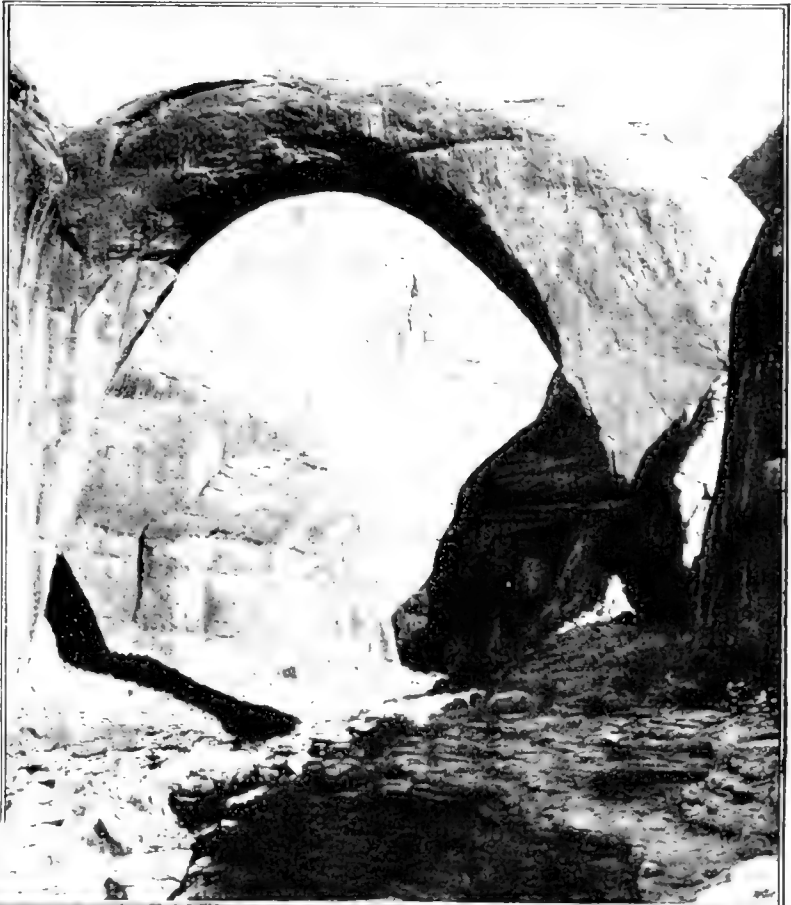

# Queer Uses of Railway Cars



At left, one of the rescue cars operated by the Bureau of Mines. Each car is manned by experts and is equipped with every device known to science that will aid in saving lives in disasters in the mines

Below, a train-lighting instruction car which is a specialized school on rails for railroad men

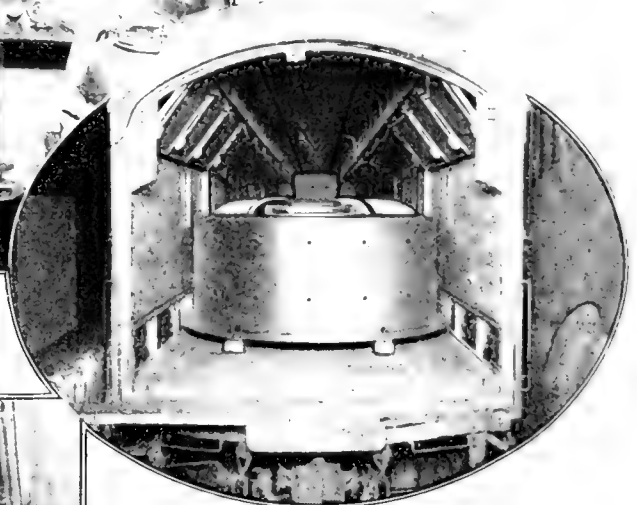

Below, an express car turned into a printing plant where a daily paper was published en route to a convention

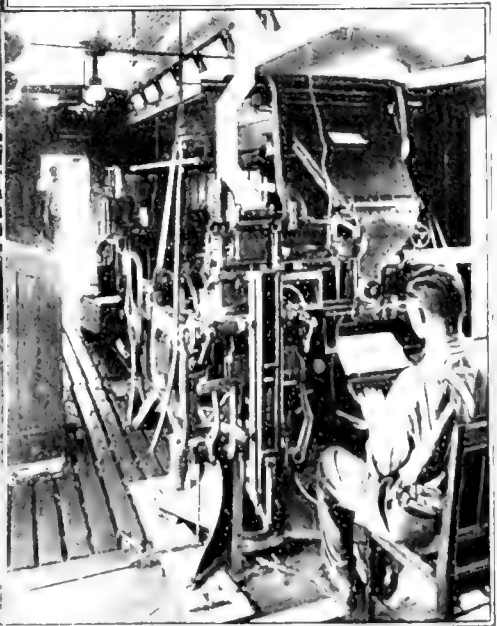
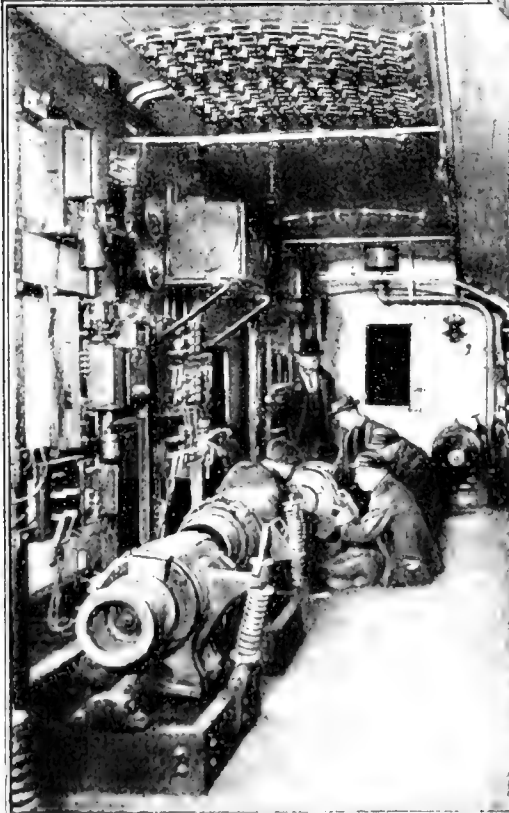

# Queer Uses of Railway Cars



A traveling emergency hospital with an operating table, closets for medicines, washbasins, sleeping cots and all conveniences for giving first aid to the injured

A chemical test-car, the only one of its kind, is designed for making tests and inspections of steel rails at specified points along newly constructed railroad lines

At left: The students of Blackburn College, Carlinville, Ill., are using discarded sleeping cars for dormitories during the spring and winter months

Below: Each coach has forty upper and lower berths, two drawing-rooms and two washrooms. The girl students are their own porters and make their own beds

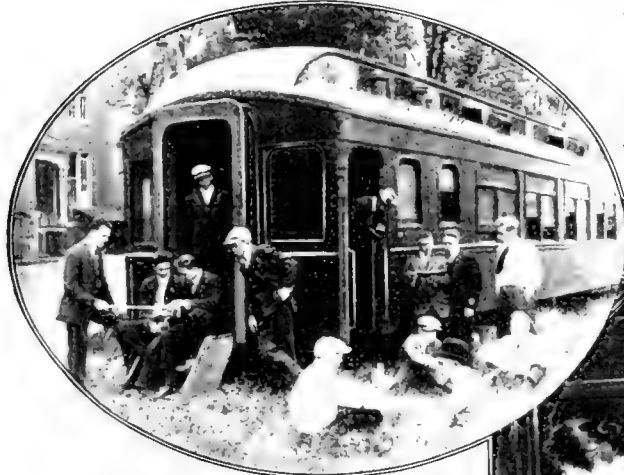

Below: Removing one of the two cars used as dormitories from its tracks and placing it on the college campus. This car is used by the boys





## How London Cares for Soldiers' Babies



16. "Graveland Underwood", N. Y.

"War" babies in a London day nursery. They will not know until later, or perhaps never, that father was away at the front shooting enemy soldiers with shot and shell provided by mother in the ammunition factory at home while they spent happy days in the nursery



## And This in a Mechanical Age!

A horse driving a type of threshing-machine often found on small farms in northern France. Americans long ago outgrew this expensive and wasteful method of obtaining driving power

The second picture shows a water-wheel driven by a horse attached to a gin. It irrigates a small farm near Toulouse, France. Horizontal troughs receive the water drawn from the well. The ancient Egyptians invented this abomination

Below: A dog-treadmill used in France. The wheel is belted to a pump which raises water into a market-gardener's tank, near Orleans

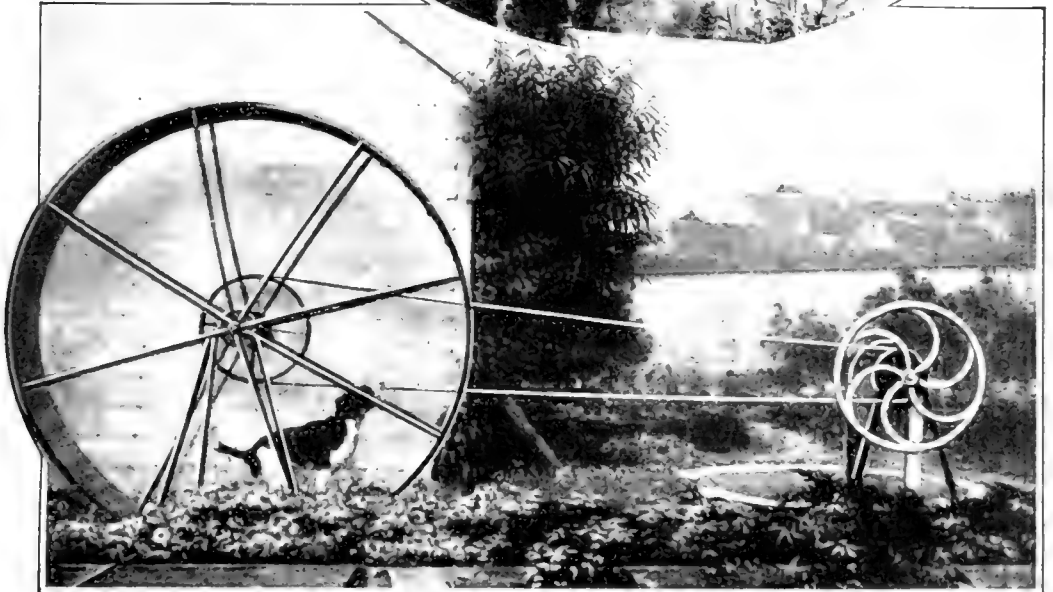
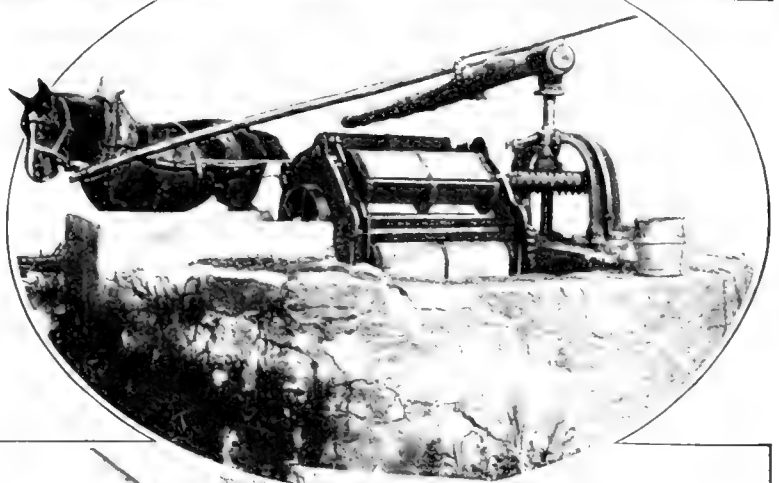
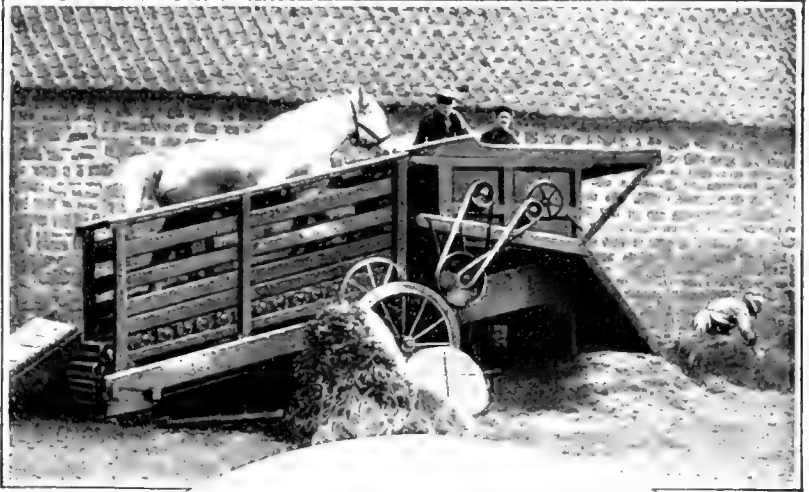

# Lost Comets and Their Story

By J. F. Springer

PERHAPS the most mysterious of all the heavenly bodies are the comets. Some are never seen except with the telescope, or else they appear as faint starlike bodies in the sky; others blaze forth, grotesque and fantastic of figure and brilliant in appearance, to excite and appal the ignorant. But always, whether dim or glorious, the appearance lasts but a moderate period at the most, and then the visitor is gone.

Astronomers make observations with instruments of precision and seek to follow the departed heavenly body by prolonging the ascertained path of its movement. And there has been a good deal of proved success in this work. For astronomers have in the case of some comets found that the orbit was a closed curve—an ellipse—and have thus been able to state in advance the time when and the place where a return would occur.

The most notable instance of a comet which continually returns is that of Halley's Comet. This remarkable body rushes through space in an elongated ellipse of such size that three-quarters of a century elapses between visits.

But there are comets which dazzle the sight for a period and then disappear never to return. Still others begin as regular visitors and then fail to reappear. Those comets which dart in from the outer regions of the solar system for a single glance at the earth and its inhabitants we are content to let depart without any especial concern. But when a comet makes regular visits and then disappears irrevocably

The comets blaze forth in fantastic glory occasionally exciting both curiosity and awe

erably, we are apt to feel perhaps that something has gone off from us whose place was with us. It is a case of a *lost comet*.

*Thrown Off the Track by Jupiter*

In the summer of 1770 a monstrosly large comet appeared. Its apparent area was twenty-five times that of the moon. Astronomers made observations from time to time during its sojourn of several months. Difficulty was experienced in determining whether the comet was traveling in an open or a closed curve. If the orbit was an open curve, then there would be no reappearance as long as this character of orbit was followed. Finally, however, the astronomer Lexell succeeded in establishing that the comet was moving in an ellipse and that it should return in five and one half years. It is not known that this comet ever did really return.

There was so much ascertained about its movements during its short stay that astronomers were reluctant to give up this comet of Lexell's. Investigation showed that, before its appearance in 1770, the comet had probably been forced into a somewhat different path from that which it had been following. In 1767, it had come within range of Jupiter's influence which may very well have modified its orbit into the curve noted by observation during the visit three years later. It was thought by Burckhardt, a French astronomer, that probably another passage near Jupiter had resulted not in creating a smaller orbit but in enlarging the ellipse. The new path that was calculated required the comet to reappear once in a period of sixteen years. However, the comet has never again been recognized. Lexell's Comet is for the present a lost comet.

In each of the years 1772 and 1805 a comet was observed. Again, in 1826 Biela, an Austrian officer, discovered a comet which was soon ascertained to be

very probably identical with the comet seen in the earlier years. This body became celebrated from the fact that calculations showed that upon its next return in 1832 it would pass the orbit of the earth at a distance of only twenty thousand miles. A slight derangement of its orbit and it might approach more closely still. If the earth should be in the immediate vicinity at the time, then our planet's own attractive power would probably result in the comet coming into collision with us. The figures showed, however, that the comet would

reach the region of close approach a month earlier than the earth. It seems, though, that it was a close shave. People at the time appear to have been stirred up over the possibilities. The comet came into view again at the period expected, but no untoward results occurred.

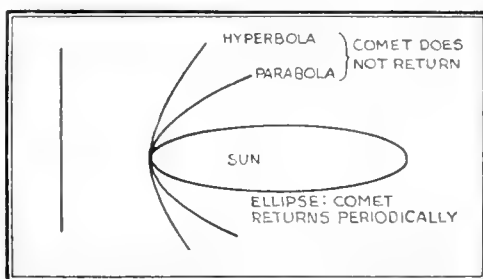

Sir Isaac Newton proved that a heavenly body controlled by our sun moves in an ellipse, a parabola or an hyperbola

Forty years later, in 1872, the comet, according to the astronomer, Klinkerfues, actually *came into contact with the earth*. He telegraphed to another astronomer his statement as to contact and suggested a search in a certain definitely named locality of the heavens. Here, the second astronomer actually saw *some* comet, but was unable because of unfavorable conditions to carry his observations very far. It is uncertain whether he saw Biela's Comet. If he did, then he was the last observer of that remarkable heavenly body.

Enough happened, however, in the forty years, 1832-1872, to lead us to think that very probably Biela's Comet has disappeared forever as a comet and that it is now a stream of comparatively tiny bodies. This statement requires explanation. In the first place, Biela's Comet broke into two separate parts, each becoming a complete comet. The two bodies traveled more or less closely together for a number of years. That there were two comets instead of one was first observed in 1846. While under observation by astronomers at this time,

## Halley's Famous Comet



This is Halley's Comet — the most famous of periodic comets — photographed at Yerkes Observatory during its last appearance. The stars in the background appear as straight lines because the camera was moved to follow the rush of the comet across the line of vision.

the larger or more brilliant of the two was seen to have three tails arranged at equal angular intervals about it. One of these tails extended over to the smaller comet and formed some kind of connection with it. There was in fact a bridge of light between the two. The two comets were again seen in 1852, when they were still traveling along together. The interval between them, which was less than 200,000 miles in 1846, had now increased to 1,270,000. The comet seems never to have been certainly seen since this occasion. But, what was certainly seen was a great shower of "shooting stars." These luminous meteors seemed to radiate from just about the point where the orbits of Biela's Comet and of our earth cross each other. The date of the star-shower was some twelve weeks later than the time when the comet itself should have made the crossing. What these facts, when considered in the light of still other information of an astronomical character, mean is probably this: After 1852, Biela's Comet broke up into small bits of matter. These possessed individually the onward motion of the comet and were held in restraint by the sun (and any nearby planets), so that the pieces generally followed the orbit which the comet itself had been pursuing. The result was a long stream of very small heavenly bodies. When on November 27, 1872, a part of this stream came within the reach of the attractive power of the earth, the separate bodies fell through our atmosphere. The friction of the enormously rapid movement resulted in heating them up to incandescence. These fragments of the original comet thus became luminous meteors or "shooting stars." In 1798 and 1838, there were notable showers of stars at times and places which were near the position and time calculated for Biela's Comet for those years. These showers, in contradistinction to that of 1872, seem to have preceded the comet, itself. In fact, putting everything together, there would appear to have been a stream of small bodies five hundred million miles in length.

The foregoing suggests that when a comet is lost, the real fact may be that it has burst into multitudes of fragments.

Another comet which belongs to the

list of the lost ones was first discovered in August, 1844. Apparently, Di Vico was the first to get even a telescopic glimpse of it. However, the comet rapidly approached our neighborhood, so that it was not long until it was visible to the naked eye. Di Vico's Comet was found to be traveling in a closed, or elliptic, orbit of such a character that it would return once in every period of a little less than five and one half years. The next return would accordingly be in the early part of 1850. Unfortunately, the comet, if it really returned, was too unfavorably situated with respect to the sun to be seen. However, in 1855, conditions would be advantageous. But no comet was seen then. Nor has this body ever certainly been seen since.

#### *What Became of the Comet of 1264?*

One of the most notable of the heavenly bodies which have more or less title to a place amongst the lost comets is the comet of 1264. This body engaged the attention both of Chinese and European writers. In 1556, another great cometary vision was seen in the sky in Europe and in China. Astronomers who studied the available data concluded that the two were one and the same comet. Calculations indicated that the period of revolution about the sun was somewhere in the neighborhood of three hundred and two to three hundred and eight years. Consequently, this great comet should have reappeared in 1858 or within a few years afterwards. It has, apparently, disappeared forever. In the year 975, a great comet was seen whose course has been thought by one astronomer to have possibly been that of the comet of 1264 at that time.

It is of interest to note that a comet may disappear because its elliptic orbit has been deranged into a parabola or an hyperbola. Sir Isaac Newton showed that a body controlled by our sun moves in a curve which is some one of the sections of a cone—that is, either an ellipse, a parabola or an hyperbola. As the latter two are open curves, a comet which pursued such a path would go off into space never to reappear. A derangement of orbit from closed to open curve has doubtless happened often.

# Pumping Gasoline to the Motor

A WESTERN manufacturer is marketing a device designed to eliminate the troubles encountered in the feeding of gasoline to the motor of an automobile from a tank by gravity during hill-climbing, when the carburetor is higher than the tank, or for keeping the feed-lines from leaking when the pressure system is used. It feeds the gasoline automatically and positively by utilizing the vacuum of the motor on its intake-strokes. The vacuum system feeds the gasoline on the steepest grades. It is not dependent upon the tightness of the feed lines for its operation, as in the pressure system.

The device consists of two small tanks, one within the other, usually mounted on the dash under the hood. The upper inner tank is connected with the intake manifold, while another pipe connects it with the main gasoline-supply tank. The lower tank is connected with the carburetor.

The intake-strokes of the motor create a vacuum in the upper tank. Gasoline rushes from the supply tank to fill the vacuum. As

the gasoline thus flows into the upper tank, it raises a float to a certain height, thus shutting off the vacuum-valve, at the same time opening an atmospheric-valve at the bottom of an air-vent pipe as shown in the accompanying illustrations.

By this arrangement the gasoline can now flow down into the lower tank, which is always open to the atmosphere by means of an air-vent at the top. When the float in the upper tank drops, as the gasoline flows down, it automatically re-opens the vacuum-valve. More gasoline is sucked in, and simultaneously the atmospheric valve is shut off. A study of the illustration in the oval will make this clear. The process is repeated continuously while the motor is running, and however steep the grade there should be no trouble encountered in the feeding of gasoline to the motor.

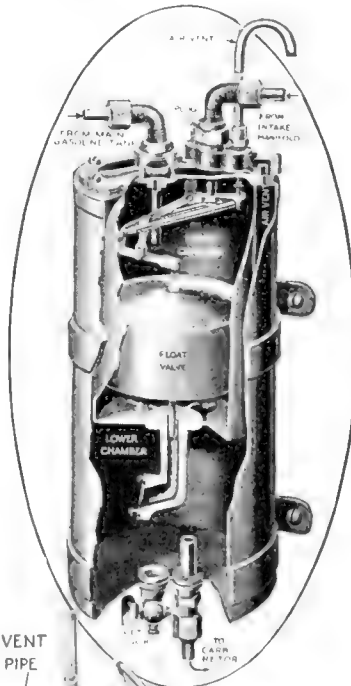

Detail of the vacuum gasoline feed. When a vacuum is created by the motor on each intake-stroke gasoline rushes into the upper chamber. The float-valve rises with the gasoline, cuts off the vacuum-valve, and opens the valve leading to the lower chamber, so that the gasoline may pass down into the lower tank

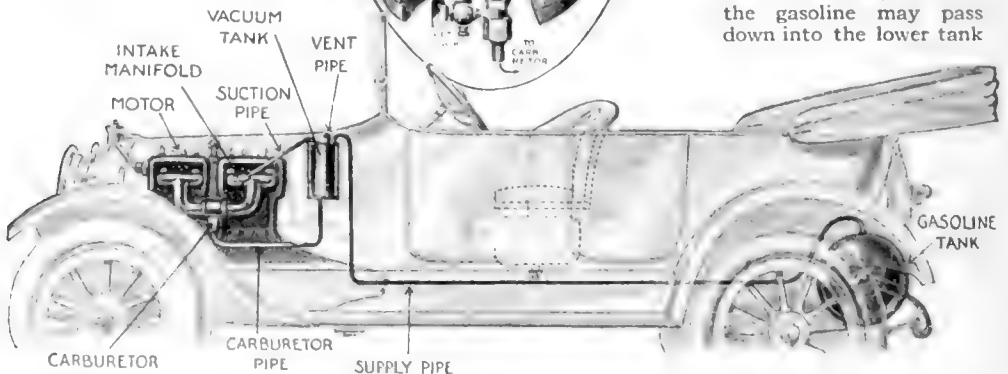

Sectional view of automobile. An arrangement whereby the vacuum created by the motor on its intake-strokes causes a flow of gasoline to the motor, thus eliminating the feeding trouble usually encountered on steep up-grades with the gravity or pressure systems

# Decoy Ducks that Quack and Swim



The ducks are composed of two separable parts which enclose a phonographic contrivance which emits a natural-sounding quack, or call, at predetermined intervals

**W**HEN Amos C. Vaughan of Anadarko, Oklahoma, goes duck shooting he takes with him a set of his mechanical decoys and places them in the water in front of his blind. Before doing so, however, he winds them up. When a flock of wild ducks appears his decoys begin to swim about and quack as if they were alive. The result is that the inventor goes home with a full bag, for no wild duck can resist the mechanical wiles of his decoy.

His duck is provided with a phonographic means for automatically giving at predetermined intervals a call or cry. It swims about in the water with the aid of the propeller and an adjustable rudder, either in circles or in any direction the hunter wishes.

The decoy is composed of two parts, bottom and top, which can be opened for cleaning and repairing. A clock-

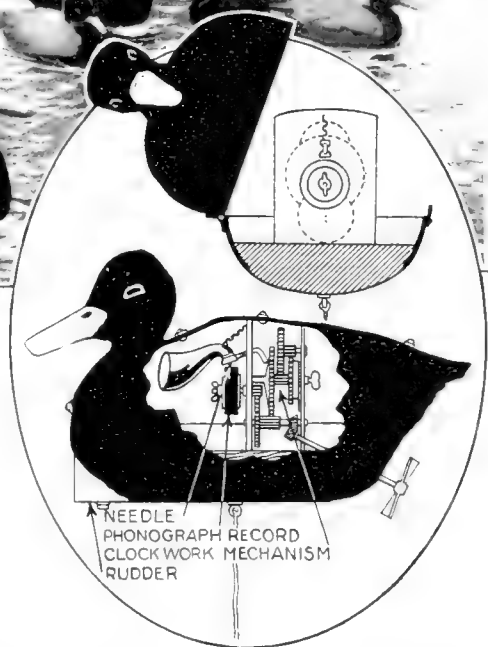

work mechanism drives the propeller and also the sound-record of the phonograph. As the mechanism is set in action the stylus, or needle, as well as the propeller is operated. A cylinder or disk is used for the record. A controlling cam renders the needle inoperative at certain intervals, so that the call or cries are sounded intermittently. Who makes the phonographic record of the quack that leads a duck to its doom? We are baffled.



## A Famous Outdoor Organ

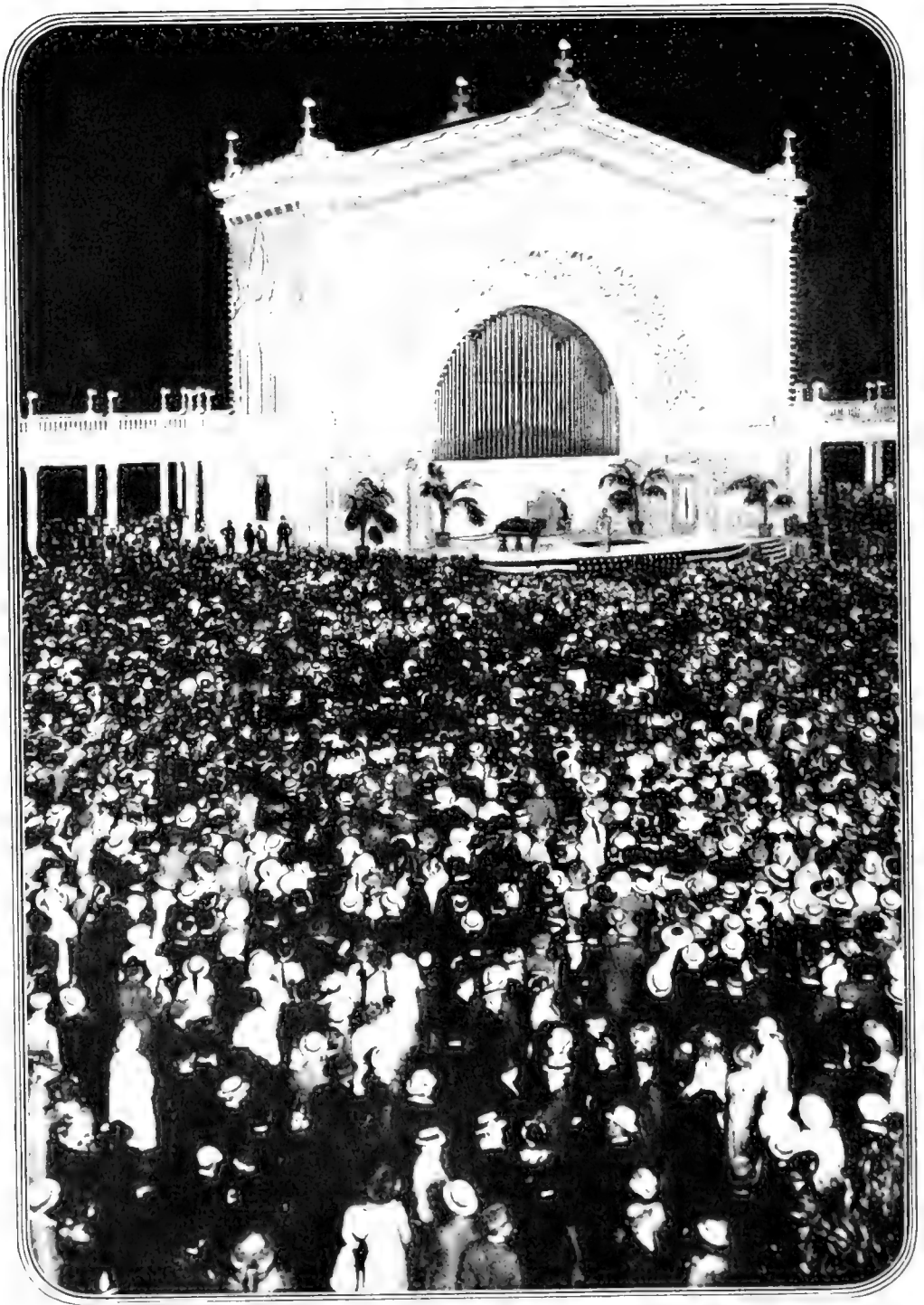

When Festival Hall was demolished along with the other buildings at the Panama-Pacific Exposition, the famous organ was removed to San Diego, where it remains a permanent attraction used for outdoor concerts, as the gift of Rudolf Spreckels

**A Curious Clock Built on a New Principle**

**I**N this very interesting clock the time is recorded on a parchment strip five-eighths of an inch wide and eighteen inches long, from which the ball is suspended. The time is indicated by a figure of Father Time placed at the edge, his fingers pointing to the hour. No mainspring drives the clock, the motive power being supplied by the total weight in the moving ball and Father Time. A lever controls the movement.

As soon as the ball is suspended the clock begins to go and continues to go until the eighteen inches of parchment have been unwound, at the end of thirty hours. To rewind the clock, the ball is simply lifted up to whatever the time may be. If lifted too far it can be pulled down. It does not drop for it is kept in position by a friction spring. A small mainspring winds up the strip.



Father Time points with his finger to the hour and the clock has no need for any other "hands" to designate the exact time

**A Heat-Resisting Socket for High Wattage Lamps**

**T**HE tremendous wattage necessary for the high candle-power lamps now so generally used, has put the illuminating engineer to the task of devising a socket capable of "standing up" under the intense heat which

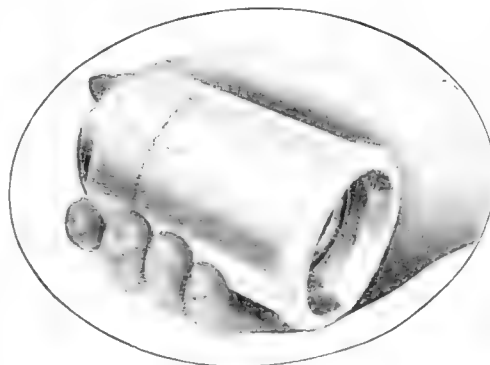

The socket is larger than the usual receptacle for the lamps and has a strong casing

is consequently generated in them.

The cost efficiency of high-light units has created an increasing demand for lamps of large candle-power. With the increased wattage there has developed a corresponding percentage of breakdown in lamps and sockets which is due to the intense heat developed.

The socket shown in the illustration at the bottom of the page is larger than the usual lamp receptacle, with a casing built especially strong to withstand almost any kind of rough usage.

The conducting paths are insulated and sealed with a compound said to be capable of withstanding any heat to which it is likely to be subjected in service.

**The Money Value of Two Great Discoveries**

**I**F WE count the wealth of North America and South America as it seems to-day, we find that the discovery of America by Christopher Columbus has been worth to the world three million dollars a day from the time he sailed from Palos in August, 1492, down to the present time. Likewise the man who discovered the way of drawing tungsten wire gave three hundred million dollars' worth of light yearly.



This tree was probably pinned down beneath a piece of heavy timber or fallen tree-trunk when it was a mere sapling

At right, a branch of an old sugar-maple has been incorporated in the body of an adjoining tree about fifty years younger

### Freak Trees. How Did They Happen ?

TO the person who is not versed in forest lore the grotesquely bent tree trunks that are to be found in almost all woods are mystifying and wonder is often aroused as to the cause. Foresters will tell questioners that in the case of trees in mountainous country and other sections where the snowfall is heavy, the weight of snow is responsible in most instances for the queer twists they assume. When a tree is young the weight of snow that falls on its branches often bends the trunk over until it is flattened to the ground. Sometimes it is buried

under six or eight feet of snow and held in that position so long that when warm weather comes the tree fails to spring back into its normal position. The summer sun causes the tip of the young tree to turn upward and if it manages to withstand the weight of the snow of the next winter, that portion of the tree will, as a general rule, continue to grow in a normal way. "Hair-pin" bends and other odd shapes result.

The bending over of a small tree under the weight of a heavy branch or tree-trunk that falls on it also results in producing



these seemingly freakish formations.

A curious tree stands on the top of Tunnel Hill, Johnstown, Pa., about four miles from town. It is a sugar maple about one hundred years old which has prolonged its own life by grafting a branch into a much younger tree.

**A Slab of Sandstone Seventy-Five Million Years Old**

**A** SLAB of sandstone stands on edge in the bed of an Ohio stream. It has peculiar markings made in times past by ripples when the stone was soft sand. The layer of rock from which this slab was broken extends far back into the bank of the stream, and comes to light again in a quarry a mile distant. In fact when the ripple marks were formed it was the soft sand of an ocean shore.

In short the pictured slab is a piece of what geologists call Berea sandstone, formed from ancient sediments at least seventy-five million years ago. To-day the Berea sandstone beds are of importance because great quantities of oil and gas are found in them.

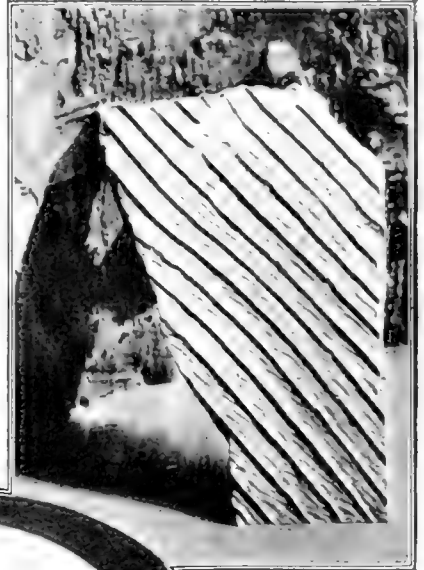

A slab of sand-rippled Berea sandstone of practically incalculable age

**A Curious Egg Shaped Like a Dumb-Bell**

**T**HE freak egg shown in the picture on the right was laid by an ordinary Leghorn hen. When first laid it was a perfect dumb-bell in shape, having two



The freak egg compared in size with a normal egg laid by the very same hen



The inner bone formation of a whale's ear picked up by a Scandinavian fisherman

yolks, one on each end, connected by a sac enclosing the albuminous portion.

**Would You Recognize the Ear-Bone of a Whale If You Saw One?**

**H**ERE is an actual photograph of a natural object. Does it remind you of a human face, exaggerated as in a cartoonist's drawing?

But it is only one of those freaky resemblances so often seen in natural objects or formations.

The photograph represents one of the ear-bones of a whale, an object about three times the size of a hen's egg. A whale has a most complicated ear mechanism, composed of several bones and ossicles of different sizes, interlocked by curious angles and facets. Sometimes one of these bones is cast up on the beach. The photograph represents such an ear-bone picked up by a fisherman on some sandy beach on the Scandinavian peninsula; and by a curious coincident it looks most like the type of face sometimes seen among the lower classes of Scandinavians.

### Putting Wheels Under Workmen Saves Time and Money

THE problem of interior and exterior transportation in one of the largest and busiest ammunition plants in this country—a plant, by the way, which was constructed in eleven months—has been solved by the adoption of automobiles, motorcycles, motor-trucks, hand-trucks, rollerskates and bicycles. The plant is worked at high pressure for twenty-four hours a day, and consists of thirteen main units and twelve service buildings, each with a main corridor one-half mile long. To inspect the various shops entails a walk of nearly ten miles, exclusive of the stairways. The combined floor area is a million and a half square feet. Between seventeen and eighteen thousand employees are on its payroll.

If it is necessary to dispatch messengers on important errands, or if the automobile used for such duty is out of repair, the motorcycle is pressed into use.

When a boy on the ground floor of building "A" is given a note to deliver on the top floor of building "M" he takes his bicycle on an elevator to the

fifth floor, mounts it, and is off on a run of two thousand feet. If not detained by the party to whom the note is addressed, he can deliver his answer to the person sending the message within seven minutes from the time he began his journey. Had he depended upon his legs, the same trip would have taken him at least twenty-five minutes.



Bicycles enable an express messenger boy service to be carried on in large factories

miniature figures of riders which follow the circumference of the track. Bicycles placed on the rollers are ridden by

athletes and the miniature figures respond readily. Races are run daily, with starters and timers officiating. The apparatus registers the time accurately and at the finish of a race each rider is given his correct time over the distance.

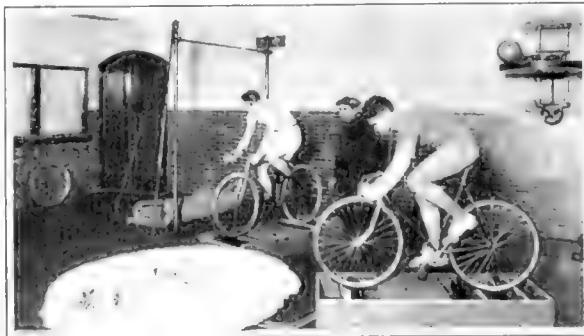

Two miniature bicycle riders race around a miniature track, their speed corresponding to that of the athletes on the bicycles over the rollers

### The Old Fondness for Cycling Is Coming Back

CYCLING is being revived in Grand Rapids, Mich., and members of the club there have installed a unique apparatus in the Y. M. C. A. gymnasium to encourage the sport. It consists of two frames, supporting rollers, which are connected by a speedometer tube with a miniature one-half-mile track. The tube

governs two miniature figures of riders which follow the circumference of the track. Bicycles placed on the rollers are ridden by

# Harnessing the Sun

By Waldemar Kaempfert

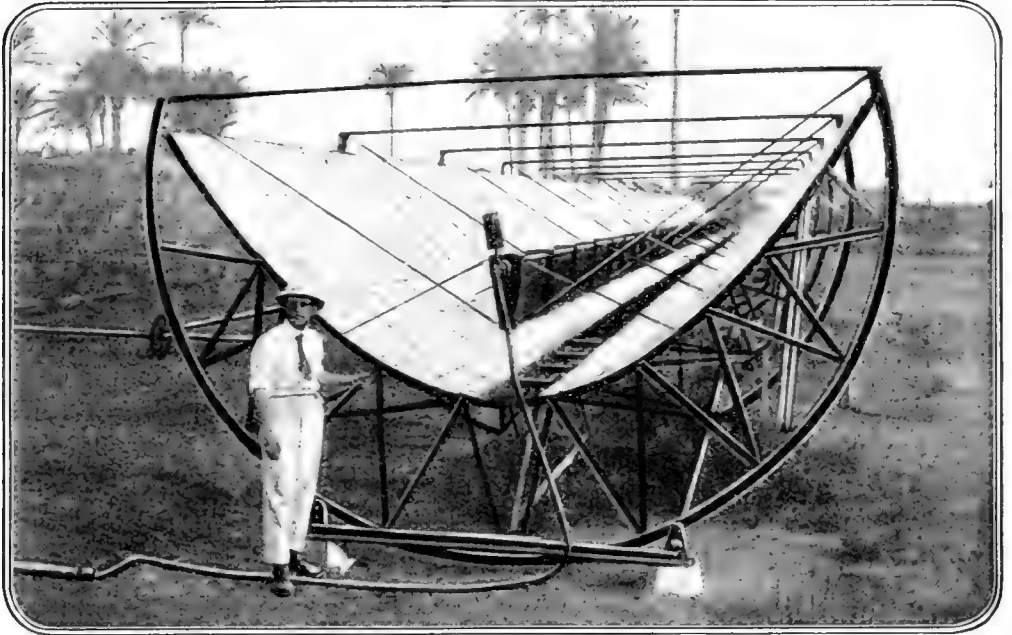

In the Sun Power Plant which Mr. Shuman erected at Maadi, near Cairo, Egypt, steam is generated by parabolic mirrors set in a light steel framework so as to throw the sun's rays upon a long trough through which water flows in a shallow stream. Thus steam is generated on the same principle applied in a greenhouse to prevent plants from freezing

**I**F a boy can burn his name on a wooden bench with nothing but the aid of a convex lens and the sun's rays, why is it not possible to make the sun boil water, generate steam, and drive an engine? It seems absurd to burn coal costing from three dollars to thirty dollars a ton, depending upon your latitude and longitude, when the earth is deluged with heat.

The thought of using solar energy for generating power has occurred to many an engineer. John Ericsson, the inventor of the "Monitor," made more than one attempt to harness the sun. In his mind's eye he saw a desert tract nine thousand miles long and one hundred miles wide, extending from the Northern coast of Africa as far as Mongolia, and great arid regions running from the southwestern part of the United States through Central America and along the coast of South America for a length of a

thousand miles, animated with millions of throbbing engines deriving their power from the sun. On a rainless strip eight thousand miles long and one mile wide enough solar heat is wasted, he figured, to drive twenty-two million, three hundred thousand solar engines of one hundred horse-power each, nine hours a day. Why, he asked, why should not upper Egypt derive signal advantage from its fortunate desert location and attain a high social position because of its perpetual sunshine?

For thirteen years Ericsson worked with diligence born of optimism. Between 1865 and 1878 he built no less than seven solar motors. Instead of a lens he employed mirrors, which were fastened on a movable frame and which concentrated the sun's rays on a boiler, when he was driving his engine by steam, and on an air-chamber, when he employed a hot-air engine. Although he

succeeded in developing about one horse-power for every one hundred square feet of reflecting surface he abandoned his plan in disgust. "The scheme is impracticable on account of the great cost of the needed apparatus," he declared. "The fact is that although the heat is obtained for nothing, so extensive, costly and complex is the concentration apparatus that solar steam is many times more costly than steam produced by burning coal."

Even if much water could be boiled by mirrors, enough, let us suppose, to develop a thousand horse-power, it does not necessarily follow that the sun motor will supplant the steam engine. Factory machinery must sometimes be driven at night. How can the solar motor do that? In the desert of Sahara the sun does not shine at midnight.

Evidently the inventor of a solar power plant must design a storage system—a piece of apparatus that can be charged with excess power and tapped at will in sunless periods. Ericsson slaved on this phase of the problem as much as he did on the invention of the engine itself. Yet his results were unsatisfactory. Some of his successors have designed machinery to compress air in strong, steel tanks; some have

planned systems in which a dynamo is made to charge a storage-battery; and some have thought of pumping water into a reservoir from which it could subsequently be drawn to turn a water-wheel. Compressed air machinery, storage-batteries, and pumps cost much money, even though the sun's heat may be had for nothing—so much money in fact that a boiler and a steam engine may prove cheaper in the end.

Askance though he might look at a colleague who really believed in substituting sun's heat for coal, an engineer could not deny that Ericsson had none too vividly pictured the possibilities that await the successful inventor in desert lands. After making due allowance for the absorption of the atmosphere, the total energy received by the earth in one day from the sun amounts to about 341,600 million million horse-power—equivalent to about two hundred and thirty million horse-power for every inhabitant.

To obtain these figures some instrument for measuring the sun's heat was obviously employed. Ordinarily solar heat is mercifully radiated and carried away as fast as it is received; otherwise the sea would have boiled away long ago, and every living thing on the earth

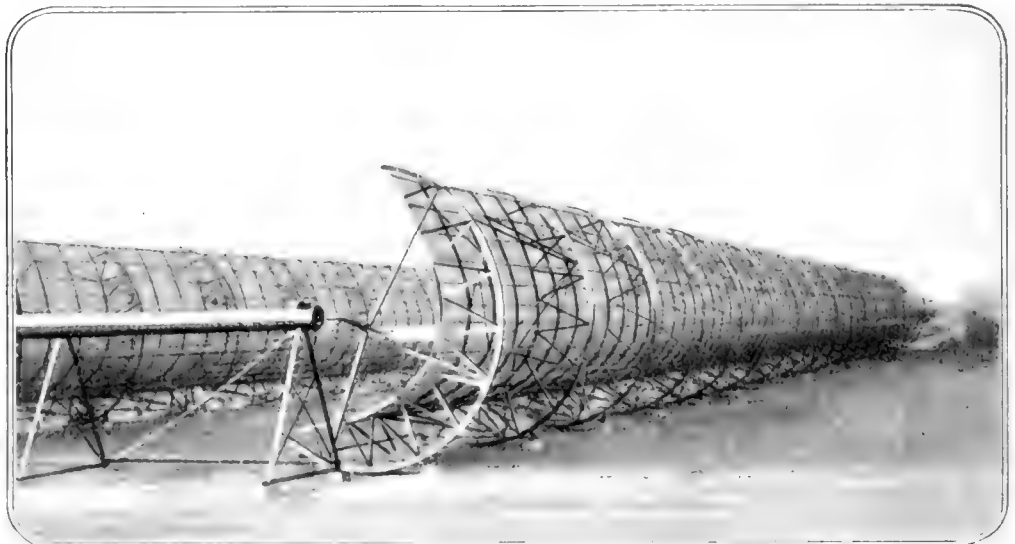

The parabolic reflectors which serve to concentrate the sun's heat upon a trough of water at their focus move automatically with the sun. This solar plant is capable of giving an average of fifty horse power. Were it located farther south, it would yield energy amounting to about sixty five horse power, making due allowance for the absorption of the atmosphere



would have been reduced to a mere cinder. If the amount of heat received is to be measured, this radiation must be checked. A heat trap must be designed. One of the earliest instruments made for that purpose was devised by the late Professor Samuel Pierpont Langley, of the Smithsonian Institution, somewhat on the lines of a gardener's greenhouse. His heat trap was simply a box provided with a double glass pane and packed with cotton to reduce loss of heat by radiation.

successful if constructed on the principle of the gardener's greenhouse and Langley's box. Mr. Frank Shuman has given us a type of solar power plant in which a thin film of water is heated in a cast-iron trough surrounded by window glass. So intense is the heat impounded by the double glass that the water is quickly raised to the boiling point (two hundred and twelve degrees Fahrenheit) or very near it.

After the water is brought to about

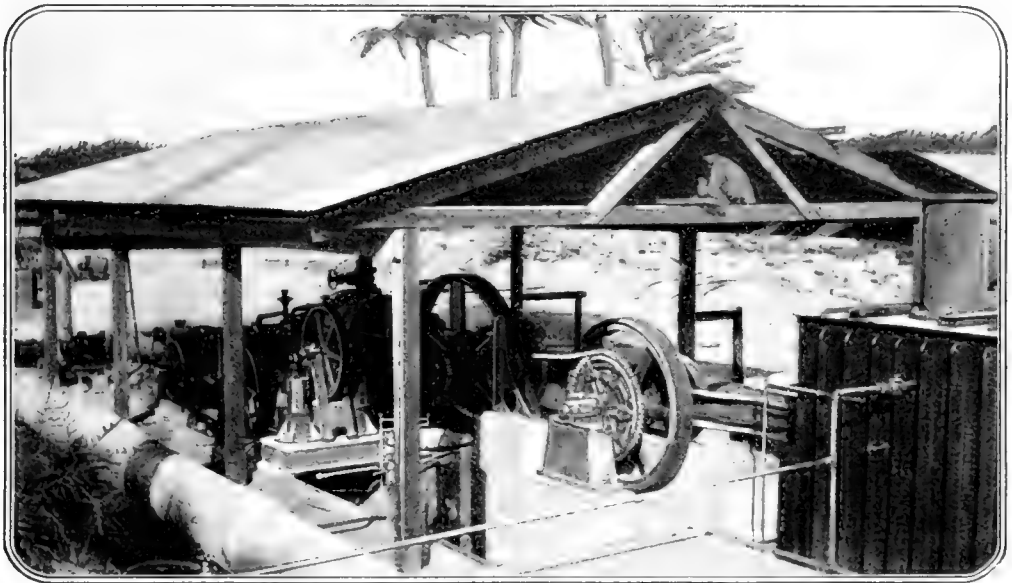

The water which is heated by the parabolic reflectors is stored in well-insulated tanks. A low-pressure steam-engine was designed by Mr. Shuman which would take this hot water and use it to drive a piston even though the pressure gained was only four pounds absolute

The layer of air between the two sheets of glass served as a heat insulator, and the glass itself prevented the heat which entered the box from escaping. On Pike's Peak, where the thermometer recorded fifty-nine degrees Fahrenheit, the temperature in the box rose to two hundred and thirty-five degrees. Had he succeeded in trapping all the heat, which is practically impossible, he might have obtained enough to melt solder. Since Langley's time, experiments conducted by Mr. C. C. Abbott of the Smithsonian Institution have given much better results.

These facts having long been known, it has occurred to more than one inventor that a solar power plant might prove

the boiling point in the trough, it is conveyed to a steel storage-tank in the inventions of Mr. Shuman. That tank is not simply an enlarged covered pot, but a vessel so constructed that as little heat as possible can escape from the water within. Just as we keep ourselves warm in winter by wearing clothes to prevent a too abundant radiation of our bodily warmth, so Mr. Shuman swathes his storage-tanks in an insulating material which keeps the water hot for many hours.

But how can an engine be driven with nothing but hot water? Mr. Shuman performs the feat by the paradox of making the water boil without flame after he has stored it. Thus he generates

steam which can be used in an engine of suitable design. It must not be supposed that he discovered the paradox, nor that he is the first to utilize it in a practical way.

When Tyndall in one of his most brilliant writings defined heat as "a mode of motion," he meant that the infinitesimal molecules of which all matter is composed are in a state of vibration. To understand his definition we must imagine the molecules of all bodies, even of so cold a mass as a block of ice, moving about at a high velocity. As soon as the temperature of the body is raised, its molecules vibrate faster, collide with one another, and are made to move in longer paths. Thus the phe-

nomemon of expansion under the influence of heat is produced. When the temperature is raised still higher, so that the solid melts and becomes a liquid, the molecules move in paths so very much greater than there is less common interference. Lastly, when the liquid is made to boil, many of the molecules are actually thrown off, and strike against the walls of the enclosing vessel, so violent is their movement. The pressure of steam or of any confined gas, then, must be regarded as a phenomenon due entirely to millions and millions of blows struck by millions and millions of invisible infinitesimal molecules. If a thimbleful of boiling water were magnified to the size of a cathedral the steam within it might seem to a gigantic eye like myriads of bullets shot in all directions. Because countless bullets strike the walls of this huge thimble not singly, but at once in very rapid succession the effect of steady pressure is produced. A single finger tap

may not even move an open door. A billion simultaneous finger taps will shut it—shut it, moreover, as if it had been pressed by a hand.

At what temperature the molecules will fly off from a boiling liquid depends entirely on the pressure to which the liquid is subjected. The atmosphere weighs down on all earthly things with a pressure that amounts to about fifteen

pounds to the square inch at the level of the sea. If water is heated in the open air at sea level the flying molecules must be able to overcome that pressure; otherwise the water does not boil. The temperature at which they can fly off at sea level, at which water, in other words can boil, is two hundred

and twelve degrees Fahrenheit. On the top of a high mountain where the atmosphere presses down with less force because there is less of it, the molecules will fly off much more readily than at the level of the sea, with the result that water will boil much below two hundred and twelve degrees. If it were possible to remove the pressure of the atmosphere at sea level altogether, water could be made to boil at the temperature of an ordinary room without heating it. That feat has actually been accomplished in the laboratory by pumping out the air in the water vessel.

What Mr. Shuman has done, therefore, is to remove part of the atmosphere's pressure from the hot water so that steam may be generated. That steam he supplies to an engine which he has designed for the express purpose of utilizing steam at low pressure. After doing its work the steam is condensed into water and is passed back to the greenhouse-like heater.

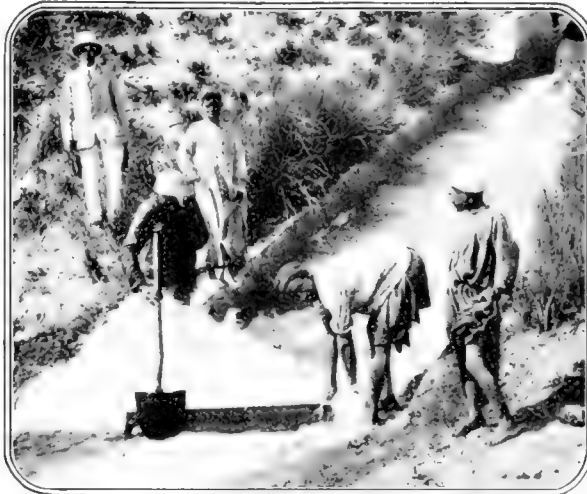

Water was easily pumped for irrigating purposes in Egypt by means of Mr. Shuman's Sun Power Plant

Shipping Sugar-Coated Education  
by the Trunkful

**B**ORROWING the idea of the traveling libraries, the Bureau of Visual Instruction, of the University of California, has perfected a plan for sending out trunkfuls of information and educational exhibits on interesting subjects. The exhibits illustrate processes by which raw wheat or oats are made into cereals, hides finished into shoes, lead and oil made into paint, snow converted into electric power, crude oil into fuel and lubricants, rubber into tires, graphite into pencils, hemp and flax into rope, etc.

The object is to intensify interest in places and products and in industrial and social development, but to do it in such an interesting way that the educative element will be completely wrapped up in the entertainment, as the medicated pill is seemingly lost in its sugar coating.

The particular exhibit illustrated here concerns the manufacture of paint. Slides containing the printed information covering all questions that might arise on the subject, are drawn out at the sides of the cabinet, while in the cabinet itself are slabs showing different tints and vials containing the different pigments and ingredients used. The stand is collapsible.

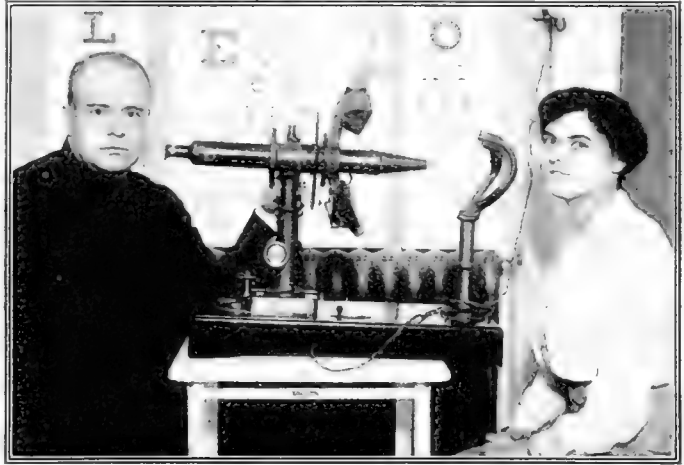

Preparing to examine an employee in the United States Treasury Department to determine the effect of the work on the eyes

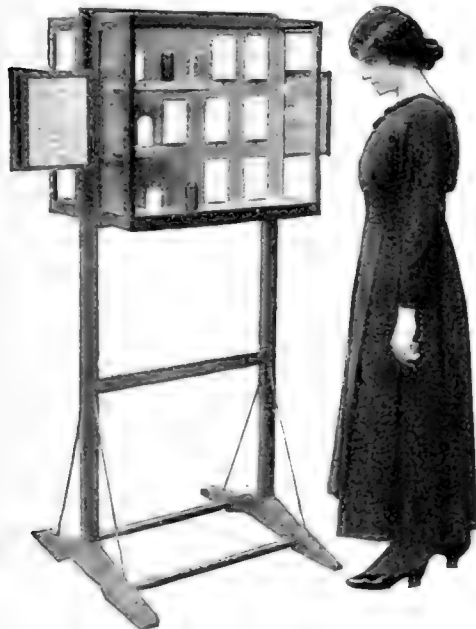

A traveling-trunk exhibit showing the processes and materials used in making paint

Have You Perchance a "Vocational Disease?"

**I**N an exhaustive study which is being carried on by the United States Public Health Service a great many interesting things are being found out about the effects of various vocations upon government employees. For example, all of the workers in the Treasury are having their eyes examined to determine the effect of confinement upon the men and women engaged in making our money for us. These tests are being conducted by Assistant Surgeon-General Kerr.

In the accompanying photograph, Dr. George H. Collins, of the Public Health Service, is preparing to examine the eyes of a treasury employee. After he has made the test he will prescribe for her eyes, if necessary. An interesting sidelight of the investigation will show whether or not the lighting system of the Treasury Building is good. Steps are already being taken to correct many of the lighting faults that have existed.

# Pocket-Flashlight Distress-Signals

A NEW system of warning approaching vessels along the Atlantic Coast when danger is near and of signaling to craft in distress has been adopted by the United States Coast Guard. It involves the use of pocket electric flashlights instead of the flaring red torches formerly employed. The new light will permit signaling to vessels at greater distances than has heretofore been

causing a dry cell battery. At one end there is a parabolic reflector about five inches in diameter. Fitted at the base of the reflector is a six-volt bulb with a highly concentrated tungsten filament. At the other end is a "key" or switch to turn the current on or off and flash the light. Messages are sent by long and short flashes, corresponding with the Morse code dots and dashes.

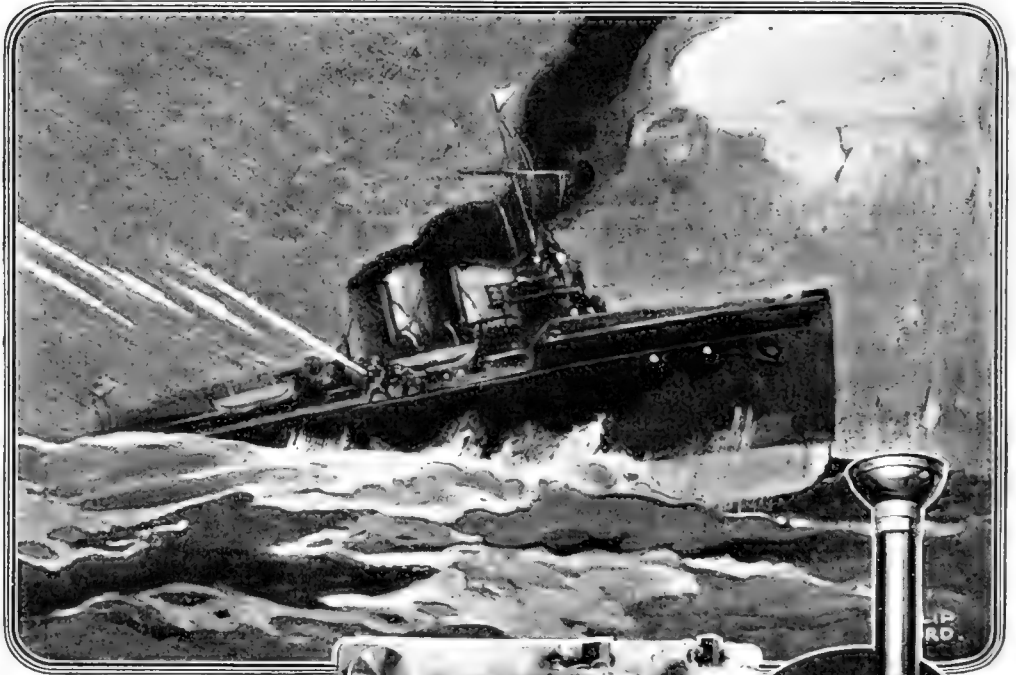

The flashlight consists of a heavy nickel-plated barrel encasing a dry cell battery and having at one end a parabolic reflector fitted with a bulb containing a tungsten filament

possible and will also make it possible to flash communications. Hence Coast Guardsmen can signal to a ship in distress its approximate position and tell the master the best course to safe water.

Although only slightly larger than the pocket lamps in common use, the new light produces a flash that can be seen for seven miles in good weather. It consists of a heavy nickel-plated barrel en-

Recently Coast Guard officers made experiments with the new signal light off the Virginia Capes on a stormy night. Cape Henry light, which under good conditions is visible for nearly twenty-three miles, could not be seen for more than eight miles. The pocket flash could be seen four and one-half miles.

# Piping Oil to Ships at Sea



A steamship on the other side of the bar plays the part of a hauling locomotive. Flags are used for signaling and an elevated disk designates a station to the ship out at sea



At left: Transporting the pipe-line sections into the ocean by railway

Below: Vessels to be loaded pick up buoy with hose attached and signal a pumping station

**G**REAT oil regions lie to the west of Tuxpan, which Mexican city, in consequence, has become a most convenient point for exporting oil. However, there are neither docking nor harbor facilities, because of an immense sandbar which effectually prevents ocean-going vessels from approaching the city much nearer than a mile.

To overcome this difficulty, the oil companies devised a novel method of loading oil. Long pipe lines were run out under the sea and over the sandbar. To the outer ends of these lines flexible elbow joints were attached. Nipples on the upturned ends of the elbow joints were provided for the attachment of rubber or other hose, leading from the pipe lines to the surface, their position being plainly indicated by large buoys.



In loading oil, vessels simply ride at anchor in the open roadstead, pick up one of the buoys with hose attached, signal a pumping plant on shore, and take on oil at the rate of one thousand, seven hundred barrels an hour. Even though the vessels roll, the intake of oil is not seriously retarded. Indeed, oil is taken aboard with almost the same

ease as if the vessel were tied to a wharf. Many thousands of barrels of oil are thus shipped from Tuxpan each year.

The success of the first lines at Tuxpan stimulated the installation of many others at, or near the port, until the submarine method of loading oil has become standard in the region. The method by which the pipe lines are laid is no less interesting than their function.

#### *How the Pipe Line Is Laid*

A trench is first dug through the sand dunes near the beach, until a smooth, even grade is secured down to tidewater. On this grade short ties are laid back from the beach. On these ties light rails are laid, the gage being less than a foot. On this narrow railway small cars or "dollies" ride. The pipe sections are connected on shore beside this narrow-gage track, lifted upon the "dollies," and thus transported into the ocean. A steamship on the other side of the bar plays the part of hauling locomotive to the dollies, a hauser being employed.

As a rule the lines are made up of 8-inch steel pipe and approximate a mile and a half in length. Frequently a small hoisting-engine has to be installed along the track to aid the steamship at sea in pulling the line. By fastening a cable back of a coupling on the line and running it over one of the drums on the hoisting engine, substantial aid can be given in this work of hauling.

#### A Fog-Stick Guide for Traffic on the Great Lakes

**I**N very foggy weather the barges towed by steamers on the Great Lakes are often lost to sight, so that the safety of both steamer and barge is jeopardized. The fog-stick shown in the accompanying illustration was designed to meet this condition. It is sent out from the steamer on the steel towline

by means of a pulley or block, and is run up close enough to the barge to be always visible to the man at the forward wheel and to indicate the direction in which the towline is leading and consequently the relative position of the steamer.

Rope guys hold the fog-stick at the required distance from the bow of the boat and a weight composed of a bag of sand keeps it upright. At night, or whenever the fog is thick enough to warrant it, a



The fog-stick is run out from the steamer on a steel towline by means of a pulley

lantern is suspended from the pole.

#### Why the Color of Sea Water Is Blue or Green

**W**HYY is the ocean blue? Because of the reflection of the sky? This accounts for some of the color but it is largely a matter of saltness and density. In the tropics where the intense heat and rapid evaporation cause the water to be much saltier the blue is vivid, while the further one goes toward the poles the greener the hue becomes until it is almost as vivid as the tropical azures.

# War Progress in Flying

By Carl Dienstbach

THE way aeroplanes were flown before the war seems almost ridiculous now, after men have really learned how to fly as the result of war's exigencies. The old way made them an easy prey for anti-aircraft guns and for attacking machines. When it became necessary to dart out of the range of a high-angle battery, which had suddenly revealed its presence with bursting shrapnel, or when only a quick maneuver could prevent a hostile machine from blocking the way home, the old-fashioned, steady, level flyer and slow climber proved a very death-trap.

Looping-the-loop, caper-cutting, all the acrobatic performances that attend exhibition flying became normal evolutions. Only excess power for a sudden burst of speed and climbing would avail in a perilous moment.

A fast-climbing machine, which also has the virtue of exhibiting great lifting power in the thin air of high altitudes, naturally vaults into the air easily in a difficult start on rough ground. In a critical landing—when, for instance, the ground, which, from above seems invitingly smooth, turns out to be alarmingly rough—the fast-climbing machine can easily stop its swift descent and leap lightly over an obstacle. By reducing his power while the machine is flying at

a steep angle, the pilot may even touch the ground at a very low speed.

## *Salvation Lies in High Power*

A machine thus able to deal with rough ground is most stable in rough air. An aviator fears what he calls a "hole in the air"—a pocket formed by a downwardly-twisting current. Into such a hole he drops in a sickening way because his wings no longer have an upward blast to support them. He saves himself, not by trying to climb out—a useless proceeding—but by *steering downward*, thus increasing his speed and likewise the pressure beneath his

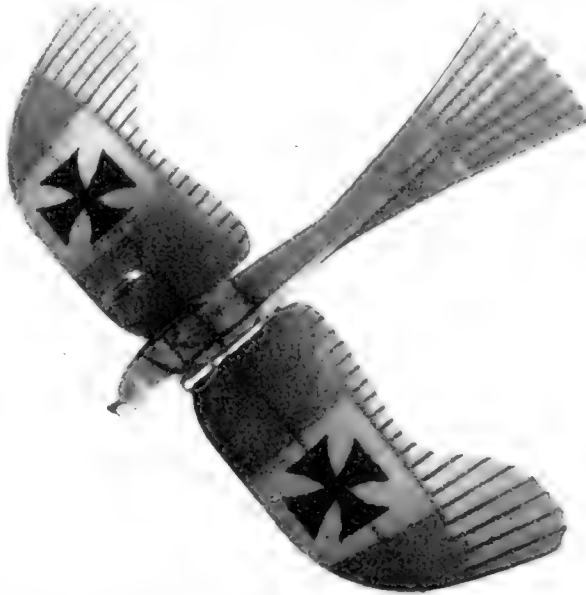

A German "Taube" in flight. We hear less of Taubes now than we did at the beginning of the war. They were standardized machines, and the war upset all preconceived aeroplane standards

wings. "To go up, one must sometimes steer up, at other times steer down," Wilbur Wright told me in his little insignificant bicycle shop in Dayton, Ohio, in 1905, in discussing the low-powered Wright machine.

Evidently the aviator needed power to combat these difficulties. This he obtained by resorting to surplus-powered and reserve-powered machines. There would seem to be no distinction between the two terms, but the difference is this: the surplus-powered machine has a motor which is more than able to make it fly and the excess power of which is constantly used for normal flight; the reserve-powered machine uses its excess only in an emergency.



In the surplus-powered aeroplane, "steering down to keep up" is not a praiseworthy maneuver. A pilot cannot possibly know how far the "hole" or local descending current extends and whether he will not plunge into the ground before he gets out of it. But with the reserve-powered machine, it is otherwise. When it steers up, it goes up—always; and what is still more important, it goes up instantly. The words "goes up" do not apply literally. They should read, "keeps up." A heavy machine cannot go up instantly on account of its inertia, but it can as instantly increase its lift as it can turn on full power and put its surfaces at a steeper angle. To steer down in order to keep up was relatively a *slow proceeding*, because even with the aid of gravity inertia cannot instantly be overcome. But with reserve power there is no need to overcome inertia, and the remedy can be applied at once.

With these explanations in mind, we understand why Europeans speak as they do of some dead officer who "lost his life because he attempted to imitate champions on high-powered machines with a weak machine."

The Germans had drawn somewhat too hasty conclusions as to the best type of a military aeroplane and had standardized it. The French simply enlisted all their current sporting types for army use, types which were inferior in long-range scouting, demanding, as it does, only reliability and sturdiness in normal flight, for which the Germans had provided at the war's beginning. But the French machines were better for aerial fighting, which has about as much to do with steady, normal flying as a free-for-all fight with walking in a procession. The new art of flying had to be learned in aerial duels, just as a boy is taught to swim by the simple process of throwing him overboard.



Maximum strength, minimum weight and least head-resistance are best attained by the aeroplane that has its propeller in front of a boat-body. But the propeller in front impedes observation. It also interferes with the operation of a machine-gun. Biplanes, such as this one, have been designed with the object of overcoming these military objections



This British military aeroplane is of the latest type. And yet how similar it is to the crude, early machines of 1908. There are only two striking outward signs of improvement: the streamline boat-body enclosing everything and minimizing head-resistance, and the solid inflexible appearance of the wings, due to the invention of enamels which strengthen and shrink the cloth covering and make it as smooth on both sides as Japanese lacquer

Daily encounters in the sky prove conclusively enough that flying has been as thoroughly mastered as horseback riding. In neither can any attention be paid to handling the machine. There are too many other very important matters to think about. The machine must respond to any subconscious action of its rider as obediently as a cavalry horse, so that its guidance becomes as much a matter of subconscious action as that of a warhorse. Accounts of air-duels read, in fact, as though fighting aeroplanes were under better control than cavalry horses. To place a shot at close range in these wild swoops, without being hit, can be compared only with fighting a saber-duel while jumping hurdles. The fastest French and British machines were found to be the most formidable fighters. Hence they were imitated (and fatally bettered) by the Germans and Austrians.

#### *And Yet, the Aeroplane Is Unchanged*

It is surprising how little the general appearance of the aeroplane has changed during its entire history, in spite of its marvelous development. Only the automatically stable types, distinguished by their backwardly-turned wings and upturned tips are an exception. But the aeroplane is such a simple device (and has been found best in its simplest forms) that the phenomenon is easily explained. There are only two striking outward signs of improvement: the streamline boat-body, enclosing everything and minimizing head-resistance, and the solid, inflexible appearance of the wings, due to the invention of enamels which strengthen and shrink the cloth covering and make it as smooth on both sides as Japanese lacquer.

Maximum strength, minimum weight and least head-resistance are best



Before the war, only two or three machines in an endurance contest, in which perhaps twenty acroplanes were entered, reached their destination. But now we hear of flocks of fifteen flying from Calais to Karlsruhe on a bomb-dropping expedition and returning safely. Surely the war has taught us much about flying machine construction

attained by the aeroplane that has its propeller in front of a boat-body. Thanks to the tractor-screw the biplane has developed as much speed as the monoplane. It is even preferred, since its greater surface gives more lift in emergencies. Unobstructed vision in front is often so desirable that the propeller is sometimes placed behind the surfaces and the boat-body shortened, in spite of the increased head-resistance and decreased strength of the design with the rudders carried by poles. A beautiful solution of the problem of free vision is obtained in large passenger-carrying machines, with the long bodies of which rudders are integrally combined, two tractor-screws and two separate motors being mounted on both sides of the main body. It is then essential to enclose the motors in separate bodies. In the big German battleplanes, the motor bodies are long and carry the rudders. Even such designs waste a certain amount of power, because a catamaran has always less speed than a single boat. But multiple bodies and division of load across the span of the planes is the only method by which large aeroplanes are enabled to carry many passengers and to exhibit that strength which it has taxed all the ingenuity of the scientific engineer to obtain even in the smaller machine.

### *Has the Big Aeroplane Come to Stay?*

Mammoth aeroplanes are at present a spectacular development, especially in America. But it would be premature to include them in a seriously critical review of the aeroplane of to-day. In the main, they have not yet justified themselves, although some of the big water machines of Curtiss, are said to be in frequent use. But there are no accounts of their performances under very critical air conditions, when their relative lack of strength would be a very serious matter, judging from the experiences of similar smaller machines. What recommended them is not economy of performance (because they carry relatively less per square foot of surface than smaller water machines) but the improved facilities offered for navigation, comfort for long trips, and the advantage

that one pilot can transport many passengers. They are also required, whenever a great radius of action is demanded, which can be obtained with aeroplanes only by cutting down the passenger list and carrying more fuel instead. In a small machine, this would mean amputating the alighting gear.

The difficulty of starting and alighting with a mammoth plane is serious. The impact of the heavy mass is too much for its strength, especially for the landing wheels, which have to be made very bulky and clumsy, consequently wasting power in air-resistance. Transformed into a flying boat the mammoth machine becomes more practical, because the hull partakes of all the naval advantages that follow with increased size. Strains to which they are subject from gusts must be formidable. But no technical accounts of their behavior in the air have been published.

Air-fighting is fully as romantic as ever were the deeds of Homer's heroes or Cooper's Indians; for this is the day of personal prowess in air-fighting. We need not dwell solely on the exploits of such German supermen as Immelmann and Boelke (each with a record of at least fifteen victories). Neither superiority of numbers nor of machines cuts much of a figure if it is matched against a certain mysterious personal equation, which cannot as yet be completely analyzed. It may be safe to say that rapid, masterful marksmanship plays in it no small part. It would be indeed a rare coincidence if this ability were likewise found combined with exceptional talents (like Pégoud's) for managing an aeroplane. If that be the case it is obvious that a fighter and flyer in one person must be more formidable than the co-operation of a mere flyer and a mere fighter. We need only imagine two cavalymen on the same horse, (assuming that they could be accommodated together as perfectly as two flyers on a machine) of whom one wields only the lance and the other manipulates the bridle. How should they communicate their respective intentions in fractions of a second?

But this holds good only in regard to small powerful racing machines which fight wasp-like at close range.

### Crossing Dangerous Rivers with Goatskin Floats



The inflated goat skins are used by the natives either as life-buoys or as river-horses

**T**HIS is not, as might be supposed, a photograph of a man with his performing seal climbing over his shoulder, but only a picture of a Kashmiri with his goatskin swimming-skin.

The skin to be used for this purpose is taken off with as little cutting as possible, after which the hair is removed and the hide softly tanned by hours of patient scraping. Then the feet and neck openings are coated with pitch—tree balsam is used in the Himalayas and

asphaltum in Mesopotamia—and sewn up so closely as to be impervious to the water. A small hole—usually at the nose—is left for inflation, and this is afterwards closed by folding over and tying with a thong.

The inflated skins are used in several ways, the simplest and most common one being as a support for the body while the vigorously kicked legs propel it across a river. In fairly smooth slow-flowing streams a paddle like the one shown in the photograph is often employed, the paddler in such instances riding his buoy like a horse. In fording the swift mountain torrents that flow into the upper Indus, a much smaller skin than that shown in the illustration is employed. The swimmer sprawls over this and uses both arms and legs as combination propellers, steering gear and buffers against the ever imminent rocks.

### Where Beautiful Hair Is Not a Crowning Glory

**T**HE man in the accompanying photograph, who is shown in his perpetual furs of human hair, is a striking illustration of what medical science calls a case of hypertrichosis, or excessive growth of hair on the human body. This man not only has locks which are the envy of chorus girls, but he has a beard and below it a hairy mat which makes him look like a prehistoric cave-dweller.

Warts and too much hair seem to go hand in hand.

On the other hand, there is no truth in the theory prevalent that abundance of hair saps one's strength, or that it signifies a great reserve of strength. People who are excessively hairy, such as the man shown, are perfectly normal except for their uncomfortable hairiness. They are not necessarily weaker or stronger than the rest of us.



The hair of the head and beard is soft and beautiful. The rest is short and furry

# The Motorcycle Machine-Gun

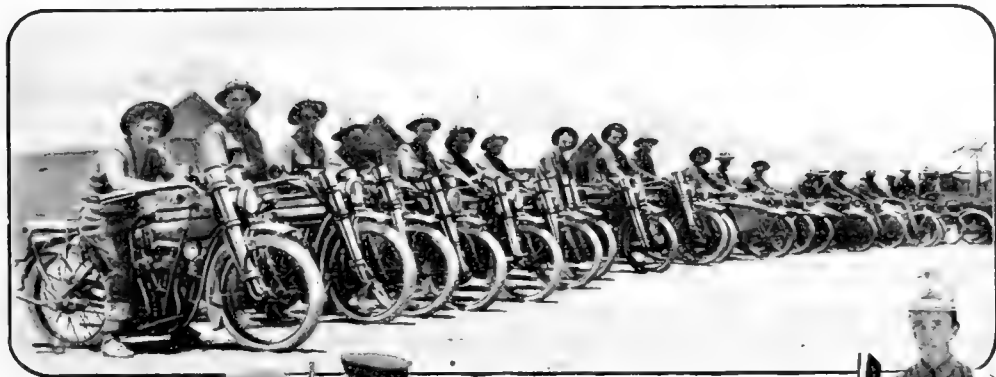

Above, our motorcycle company patrolling in Mexico  
Below, the motorcycle machine-gun car. The gun carriage can be detached or replaced in thirty seconds



**W**ILL the motorcycle supplant the cavalry horse in modern warfare?

Our army officers are not ready to give an answer one way or the other at present, but since March 30, 1916, up to which time the motorcycle had been used only for messenger service in the United States Army, Brigadier-General George Bell, Jr., had been testing the armored machine-gun car to determine whether it may not eventually supplant the cavalry horse.

After exhaustive tests over every conceivable sort of road, including no road at all, the sidecar attachments were adopted. Single machines carrying two men were found to be useless in deep sand or mud. With sidecars carrying three men in all, all manner of roads were used. At the present time a motorcycle company is patrolling the one hundred and thirty miles of Mexican border between Laska, Texas, and Noria, New Mexico.

Compared with cavalry troop movements the motorcycle has done things which seem almost incredible. On Memorial Day a report was received at Fort Bliss of a bandit raid fifty-four miles down the border. Exactly two hours later the motor cycle company, with each machine carrying three soldiers, was on the spot where the raid was reported to have occurred.

A few weeks later a raid was reported at Canutillo, eighteen miles from Fort Bliss. The motor cycle company reached this place, ready for action, thirty minutes after the order was received. The first trip would have taken a troop of cavalry two days, and the second four hours to make.

It is said that a machine-gun car and two men are equal to fully one thousand riflemen. Because of its speed army officers are looking upon it with favor.

# Hunting the Mud Pigeon

By Edward C. Crossman



A squad moving up. The three men in the rear have fired and are moving. When the first man has fired at five clay birds he will walk around the squad to the first position

**F**IVE strong men stood in a row, armed with guns and evidently much interested in something that was going to happen in the little house out in front of them. There was not much to the little house. It stood possibly a foot and a half high at the back end, toward the shooters, and six inches higher at the front. Six feet would span its length, four feet its width. It wasn't much more than a good substantial cover to the entrance to a cyclone-cellar.

The strong man on the right end of the line raised his shotgun and pointed it apparently at the top of the little house. He snuggled his face to the stock, then he barked something that sounded like "Pull," and from the shelter of the little house, fleeing straight away from the line of men there sped a little black and yellow saucer. It rose as it traveled, and in the wink of an eye it was far higher than our heads and farther from the little house than the distance to the row of men.

Then the gun cracked, and the fleeing

disk suddenly flew into a cloud of black bits. They say it takes shot a little time to cover a distance, but the black and yellow saucer smashed up almost before the gun barked.

The next man repeated the performance, only the little saucer came out from a different direction, sneaking off swiftly to the right and away from the line, but not so swiftly that the shot didn't catch up with it and end its career. The third sneaked out the opposite way, to the left, and it sped on, unharmed in spite of the crack of the gun. The man grinned a bit and shook his head, but nobody spoke. So the shoot went on until finally we began to look at the machinery that made the saucers hiss so swiftly out of the house at the word of command.

## *How the Clay Birds are Launched*

A few yards back of the center man of the row there stood a boy with an iron lever in his grasp. The upper end reached to his waist, the lower end disappeared in the ground. From our



feet as we crossed the line between him and the little house there came a queer rattling of hidden machinery. This was the "puller," and with the lever he set and sprung a throwing-machine out in the little house, like the old time instruments of war with which the ancients used to throw rocks, fireballs and other pleasantries into the cities of the other fellows.

In the little house when the squad had finished shooting, we found the machine, the trap as it is called, merely an inclined steel plate with a throwing-arm faced with rubber and impelled by a powerful, coiled spring. Inside the house sat another boy, the trapper. He set a little clay saucer, bottom-side up on the steel plate; the puller gave the lever a little twitch, releasing the trigger holding the arm, and it swept swiftly across the plate, hurling the saucer out ahead of it and giving it a rapid whirling motion as it flew. Then with the lever and a long rod reaching to the traphouse, the puller hauled the steel arm back to the set position, and the trapper placed another "bird" in position to be thrown.

Another form of trap holds the bird in a pair of steel fingers at the end of the throwing-arm, and this is almost human in its resemblance to the pair of fingers and the arm of the small boy, with which he takes the flat bit of slate and "sails" it edgewise through the air.

The saucer, or "clay bird," is made of river silt and tar—just plain mud, as a matter of fact, baked after being formed into moulds. It is four and one-quarter

inches across, and about an inch from bottom to rim. The rim is very heavy, to stand the strain of trapping; the top very thin and light. The whole "bird" is quite brittle, and usually departs this life when hit by even a single tiny pellet of No. 8 or 7½ shot.

#### *The Rules that Govern Trapshooting*

The rules of the game are that the shooters, five of them to the squad, shall stand normally sixteen yards back of the throwing arm of the trap, and three yards from one another, as marked by the row of little pegs set at the sixteen-yard mark from the house. The birds thrown from the trap shall fly at unknown angles; that is, the shooter does not know in which direction the bird will fly from the trap, which is changed in direction by the trapper in the house. But the limits of the flight are also fixed by the rules, which are that the trap shall not throw its birds higher than twelve feet nor lower than six feet at a point thirty feet in front of the little house, nor at angles greater than forty-five degrees to the right or left of the straight line from the puller down through the house and out along the grounds.

Save in a wind, the birds from a certain trap fly at the same height from shot to shot, the elevation not being changed; but they change their direction each shot. Because the shooters stand nine feet apart, and the first and last man in the line are therefore eighteen feet to the right and left of the center of the trap,



The scorer. A black "I" mark means broken or killed birds. To score the bird "dead," the shooter must break off a perceptible piece. A puff of dust will not do



In this method of shooting the man with the machine simply pulls the trigger and the clay bird soars in the air

medium between shot too small to break the clay, and too large to make a dense cloud or "pattern" of shot through which the little clay cannot escape. Usually the powder load is three drams of smokeless. The guns must weigh from seven and a half pounds to nine to absorb kick and make shooting pleasant, but this is not a rule of the game, merely common sense.

#### *How the "Events" are Conducted*

In a regular shoot, the shooters are divided up into squads of five, who remain together through the day or the whole tournament unless handicap events which require different distances for different shooters

it follows that if the man at the extreme left end of the line, who is No. 1, gets a bird leaving the trap at the extreme left angle permitted, he gets a bird that is swiftly traveling right across his line of fire seemingly.

This is termed a quarterer. If the bird, on the other hand, flew straight away from No. 3 man, who stands back of the very center of the trap, it would be a straightaway from the trap and from this man, but still quartering to the line of the others in the squad. Quarterers are the bane of the beginner, because he shoots right at them, and they are not there when the shot arrives, but much farther to the right or left.

In trapshooting the rules forbid guns larger in bore than 12, and charges of shot heavier than one and a quarter ounces. Black powder, because of its smoke and interference with the vision of the shooters and scorers, also is taboo. Because the shooter likes to shoot as many pellets as he can and still cannot shoot too small-sized shot, lest they fail to break the bird, he has found that No. 7½ or 8 shot is the happy

make re-squadding necessary. Each "event" may consist of from fifteen to twenty-five birds, each man firing at this number, then retiring with the squad in favor of the next set. To make the game fair and give every man his trial at a different peg and so a different angle to the trap, the whole squad moves up one peg when a fifth of the event is shot. In the 25-bird event when No. 1 has shot down five birds he moves up to No. 2 peg, and so on down the line to No. 5 man, who takes his gun and doll rags and walks down behind the length of the squad to the vacated No. 1 peg. After the next five birds there is another move, and so on.

Each shooter fires in turn, raising his gun and getting it in the correct position the instant the man to his left fires. The rules permit the shooter to raise the gun to the shoulder and get all settled before calling for the bird, which he does with the never-varying word "Pull!" The instant the puller hears the word, the bird is sped from the trap. The slightest hesitation in the act of the puller will effectually "balk" the shooter,

so accustomed is he to the dash of the bird on his call, and the more experienced the shooter, the more likely is this to cause him to miss.

To score the bird "dead" on the score sheet, the shooter must break off a perceptible piece. A puff of dust will not do. Many and many are the peeved shooters who see the fatal plume of dust rise from the bird, but do not get it scored to them. That means that a single pellet of shot has passed through the top of the bird, but due to the inaccuracy of the shooter's pointing, the pellet hit but the outside of the shot circle, and he has virtually and legally missed the bird.

As the shooter cannot stand nearer than sixteen yards to the trap, and in handicap events, may be put back to twenty-three yards, it follows that the bird because of its high speed, gets another sixteen yards or so from the trap before it is hit. Probably the average shooter hits his birds at about thirty-five yards from the muzzle of his gun. Here there is a circle of about thirty inches of shot, which, placed on the bird, will surely break it. So the problem of the trapshooter is to judge the speed and angle of the bird so that he can place a two and a half foot circle of little pellets in the path of the saucer. He may have to pull the trigger when the muzzle is three feet ahead of a quartering bird if he is a slow shot and a slow swinger to hit that saucer.

Because of the danger of the small saucer getting through the hissing cloud of pellets without being hit, full choke guns, which hold their charges together and shoot dense clouds, are necessary for the trapshooter, and even then there are times when the slow shot, firing when the bird has gotten so far away that the cloud of pellets has spread widely and thinned out, misses merely because his "pattern had a hole in it."

Trapshooting is a game in which the gun and the clay bird are the tools as the ball and bat are in baseball. It is not preparation for any other shooting any more than baseball is preparation for anything else. From the little houses covering the pits in which are set the trappers and traps and birds, there speed more than thirty-five million of the little saucers each year. Forty-five hundred clubs follow the game of the trap. Four hundred thousand men shoot once or more each year at the clay birds.

While the beginner marvels at the immensity of the space surrounding the little birds, and the shortness of the time available in which to locate the flying saucer and judge its angle of flight, put the gun on the right spot and pull the trigger, yet the skill acquired by the shooter following the game is wonderful. Breaking ninety of the clay birds out of one hundred in a big tournament would not put one within the first ten per cent of the men entered in the shoot unless the conditions were unusually bad. There are hundreds of instances where a hundred of the birds have been broken without a miss, while a professional shot has the record of more than five hundred straight hits. The record for 1915 was three hundred and seventy-two in competition, without a miss, four hundred and ninety-nine out of five hundred by the same man.



The puller reclining in his little house. He watches each clay bird as it leaves the machine and he knows that his slightest hesitation will "balk" the best shooter

### Eliminating One of the Tortures of the Dentist's Chair

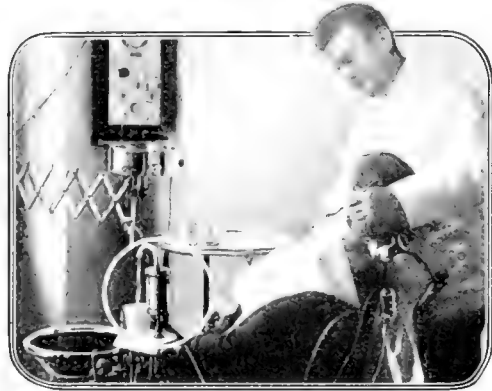

By pressing three buttons located at the back of the chair, water of three given temperatures may be immediately obtained

**C**OLD water on sensitive teeth as you sit writhing in the dentist's chair is the height of discomfort. No longer need the dentist submit you to this inhumane treatment if he uses the apparatus illustrated. An improvised form of water-heater enables him to have at his side at all times water of three fixed heats. All he has to do is to press two buttons to obtain water at the desired temperature.

The apparatus is fitted to the water fountain and three separate electric coils do the heating. The switch-control hangs on the back of the chair. By pressing one button the corresponding coil is thrown into the circuit to heat the flowing water to the steady temperature of one hundred degrees. The upper button connects two coils and raises the temperature of the flowing water to one hundred and fifty degrees. By pressing both buttons all three coils are utilized and the water is heated almost to the boiling point. When the switch is off the water is of the usual flowing temperature well known to the patients.

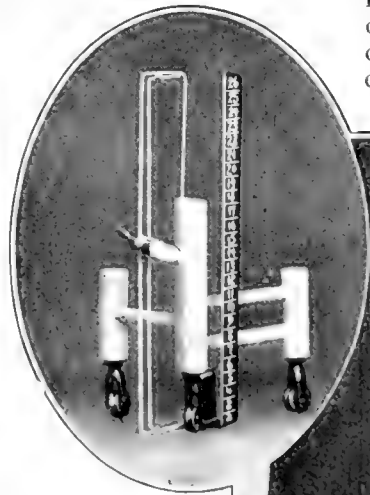

### It Was a Man Dressmaker Who Invented This

**A**N ingenious German has invented a device for accurately chalking off the length that a fashionable skirt should have. He has built a triangular frame on rollers. Attached to the frame in front is a wire-support. A piece of chalk can be fixed in the support at the right height by means of a thumb-screw, the height being accurately gaged by means of a vertical ruler attached to one of the legs of the roller-frame.

The skirt to be measured is hung on a dressmaker's lay figure, and the apparatus is so placed in front of it that the lower part of the skirt comes into direct contact with the chalk while hanging between the scale-rod and the wire frame. The frame and rod support the skirt and prevent it from slipping away under the pressure of the chalk. This makes it possible to get a clear chalk mark all the way around. Since the apparatus runs on rollers it is easily moved around the skirt, which is a decided advantage over the old way of revolving the lay-figure instead of the finger of chalk. The holder for the chalk is arranged to slide easily over the supporting rod.



The marker grasps the skirt and secures a firm surface upon which to make its line

# Preserving the Orchestra Leader's Art

THE special talents possessed by celebrated orchestra leaders are to be immortalized. What is more, it now becomes possible for the same leader to direct hundreds of bands at once from a motion-picture screen.

An orchestra leader must be photographed both as he appears to his musicians and to his audience—in other words, he must be photographed in front and in back. He takes his place, as shown in the accompanying illustration, between two cameras, which are concealed by partitions so as not to be included in the picture. Camera 1 takes the front and camera 2 the back view, while the conductor is beating time. But in each case the image covers only half the film. One-half negative registers the front views and the other half the back views.

The two films are cut in half and joined, so that we now have a single

film which carries the two sets of pictures, and which can be used in a moving-picture projector with certain modifications, as shown in our illustration.

A screen is employed, the upper half of which is transparent, the lower half opaque. The set of pictures showing the front view is thrown on to the lower opaque half which lies in front of the musicians, so that they see the leader just as he would appear when really conducting the orchestra. This is all that would be absolutely necessary as far as the musicians are concerned. But at a concert the effect is much better when the audience can see the leader as well. The second or back view comes into use here. The back view of the conductor is thrown on to the upper transparent screen, so that the audience seems to see the leader as usual. A partition prevents the musicians from seeing the upper half of the screen.

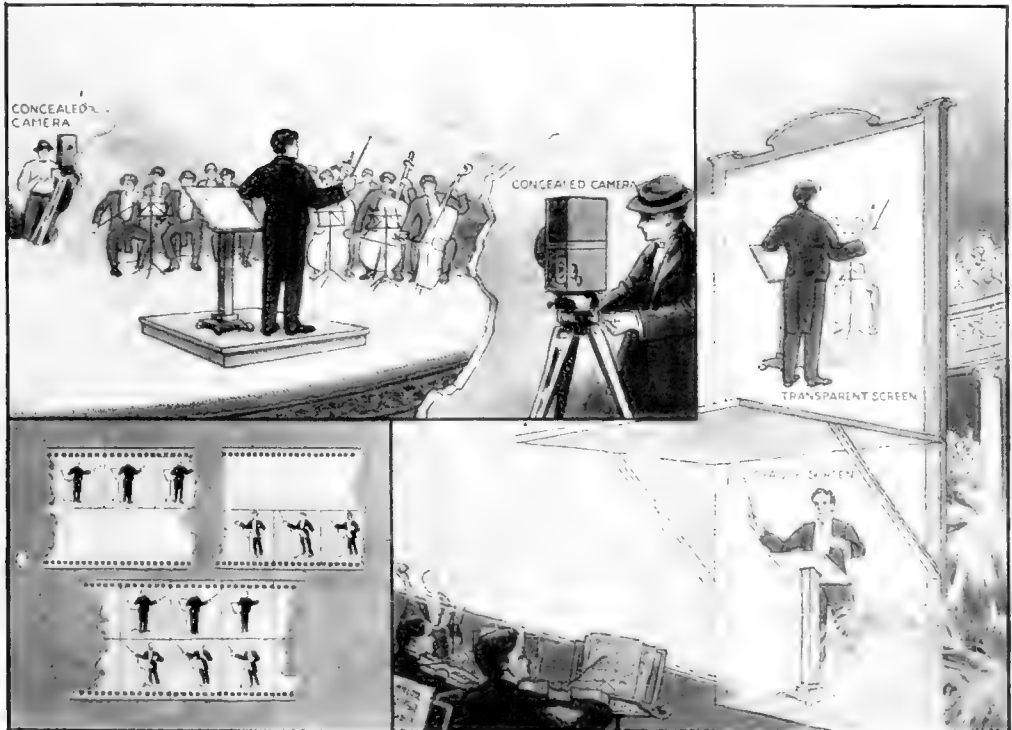

At the upper left the two concealed cameras are shown. Each takes but half a negative, the halves being pieced together as in the lower left picture. A screen having a transparent portion for the audience to see and an opaque portion for the musicians alone, is employed

### A Hand-Magnet That Lifts Fifteen Times Its Own Weight

A SEVEN-POUND hand-magnet which is capable of lifting castings of from ten to fifteen times its own weight fills a long-felt want in machine shops where it is used for clearing chips and borings out of the machinery. This is only one of its many uses, however, since it recovers dropped tools, bolts, and boring bars which could not be easily recovered from awkward places.

Where large quantities of brass and iron filings accumulate, the magnet is used to separate the brass from the iron. The magnet is used to pick up hot or awkwardly-shaped castings and can also be suspended in liquids such as paints, glazes and chemicals to attract to itself any particles of iron or steel which need to be removed.



Where large quantities of brass and iron filings accumulate this magnet will be found invaluable for separating them

### Mooring-Hook Locks Itself to Eyebolt

THE harder the boat moored on the new self-locking mooring-hook pictured below pulls, the less chance there is for the boat to get loose. In use it is merely necessary to toss the hook into the eyebolt on the dock or buoy and the yacht is fast, since it automatically locks, although there are no springs in the device. To loosen it a poke of the boat-hook is sufficient.

The lock is composed of an ordinary hook, to the tip of which is attached a lever, which catches a piece of steel in the shank of the hook much as a door-latch is caught. It cannot be loosened unless the upper end of the catch is pushed forward. This is accomplished by a thrust of the fingers or of a boat-hook in the opposite direction, from that in which the boat itself is pulling.

All pulls on the line itself are taken up by the hook. Should the line be twisted, so as to pull in the opposite direction, the pull is taken up by the lever which is caught and held.

The harder the boat pulls on the hook the less chance it has of breaking loose from this type of mooring



# Holding the Hudson at Bay

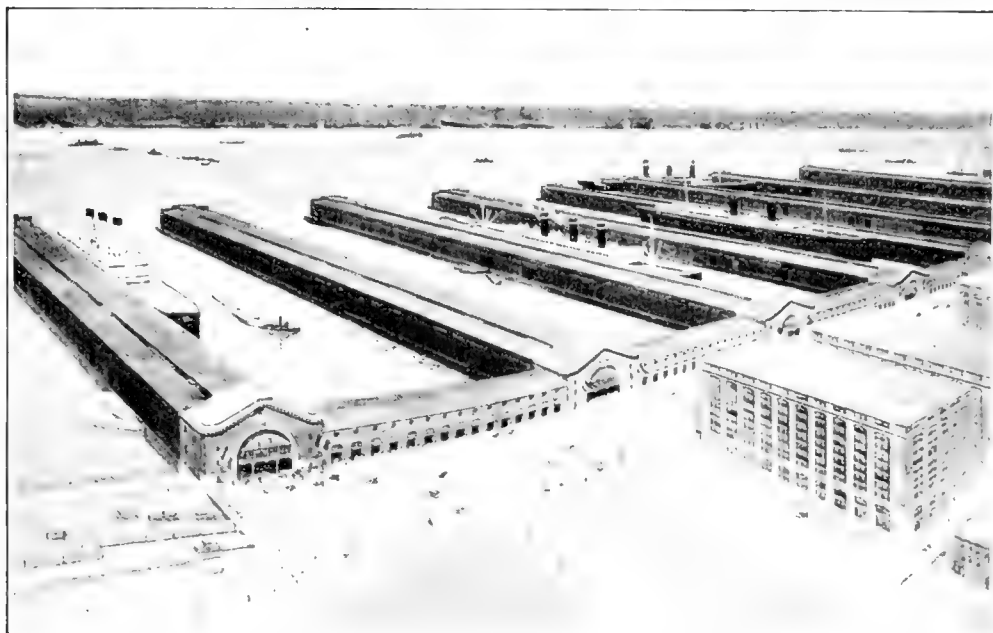

When the project is completed New York will have piers large enough to enable the world's largest ocean-liners to dock in a few minutes instead of several hours

**T**O make way for the giant steamship piers which when finished will enable the world's largest ocean-liners to dock within a few minutes, instead of a few hours, which is now the case, the City of New York, through its Department of Docks and Ferries has constructed a cofferdam which holds sixty-eight feet of the Hudson River at bay while workmen are clearing out rock from the river-bottom and laying the shore-ends of the piers.

The engineering world was much interested in the raising of the battleship Maine in Havana Harbor, where a head of water thirty-seven feet deep had to be reckoned with, but interest has now shifted to New York. At Havana the cofferdam was elliptical and the rounded ends helped to reinforce the sides. In New York the wall holding back the waters is L-shaped, eight hundred feet long on one side and three hundred feet on the other.

Interlocking sheet steel-piling was used to form the backbone of the cofferdam, and this was driven so as to make a succession of contiguous pockets ap-

proximately sixteen feet in width and twenty-four feet in length. These pockets were filled with material dredged from the river-bottom, and as it settled it turned the pockets into steel-clad pillars of earth. The steel piles were driven down to the underlying bed-rock which dipped riverward. But this was not a sufficient guaranty of rigidity. The object of shutting out the river was to enable hundreds of workmen, with pneumatic drills, to get at the rock normally below the tide so that it could be blasted away smoothly, and structural work reared upon the resultant clean ledge. This structural work is eventually to support long piers for the accommodation of liners one thousand feet in length.

To guard against any possible collapse it was decided to build a slanting rip-rap bank inside the cofferdam, and stone was piled up until the base of the dam had a width of seventy feet. But there was a point where this rip-rap could not be built; it was at the corner where the inshore end of the cofferdam joined the main body of the bulkhead. There the engineers had to have the rock uncovered



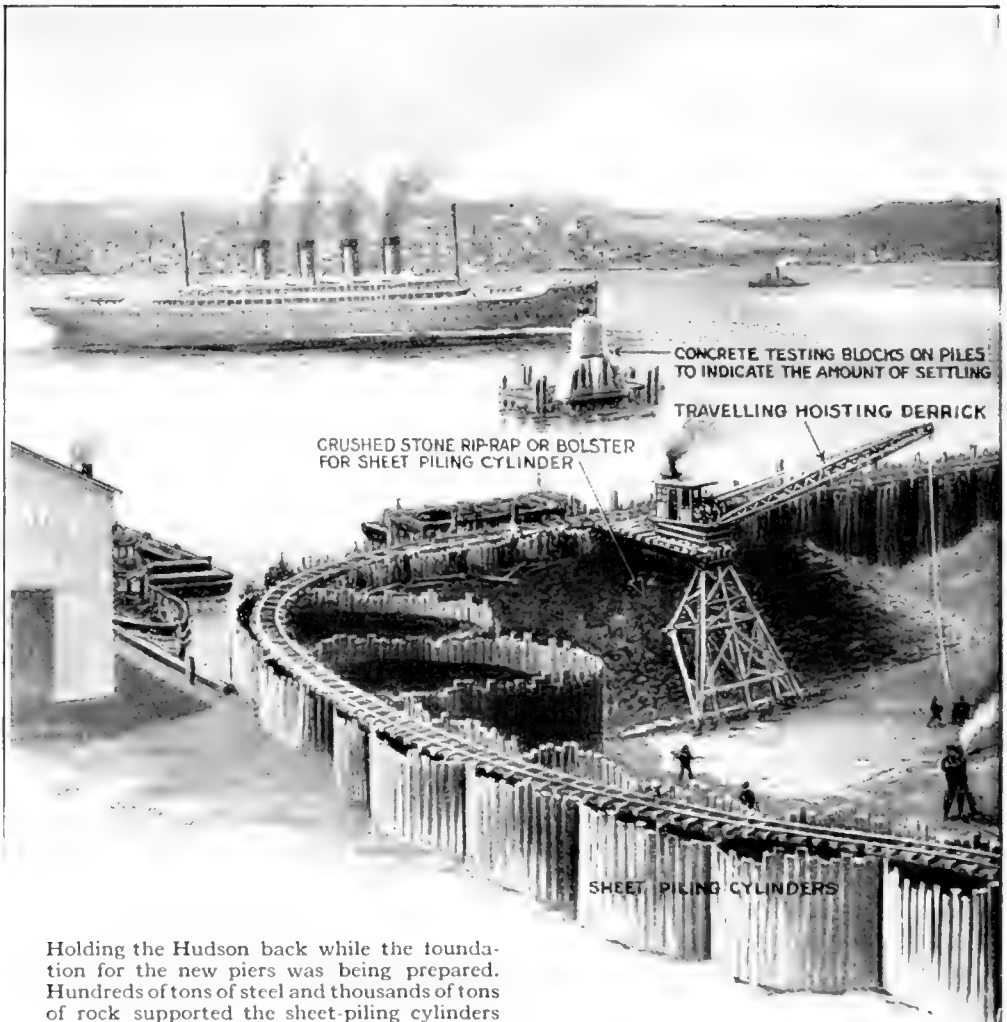

Holding the Hudson back while the foundation for the new piers was being prepared. Hundreds of tons of steel and thousands of tons of rock supported the sheet-piling cylinders

so that the drilling and blasting could be carried out close to the steel-sheet piling. To obtain the necessary rigidity, the smaller pockets were replaced by two great circular units fifty-five feet in diameter. These were filled with broken rock, which made them stable. The pressure developed in the cylinders made them watertight.

Along the stretch of cribbing a single line of interlocking steel-sheet pilings had been driven. When leakage occurred at that point it was suggested that the crevices be plugged by means of fluid cement or "grouting." The heavy expense of this remedy caused hesitation, and resort was made to another expedient, this latter proving an effective and

cheap way of halting the water. To begin with, a timber pile twelve inches in diameter was driven down into the space back of the old cribbing, and then withdrawn, leaving a hole. This cavity was filled with a wadding composed of successive layers of earth, sawdust and manure, driven down hard by the pile which served the double purpose of ramrod and plug. In this fashion, a row of wooden pilings and an equal number of water-tight wads were driven deep into the underlying earth, proving amply sufficient to stop all leaks. A little seepage, however, came up from the bare river bed, but a small pump was sufficient to handle it. At Havana, pumps had to work constantly, and at

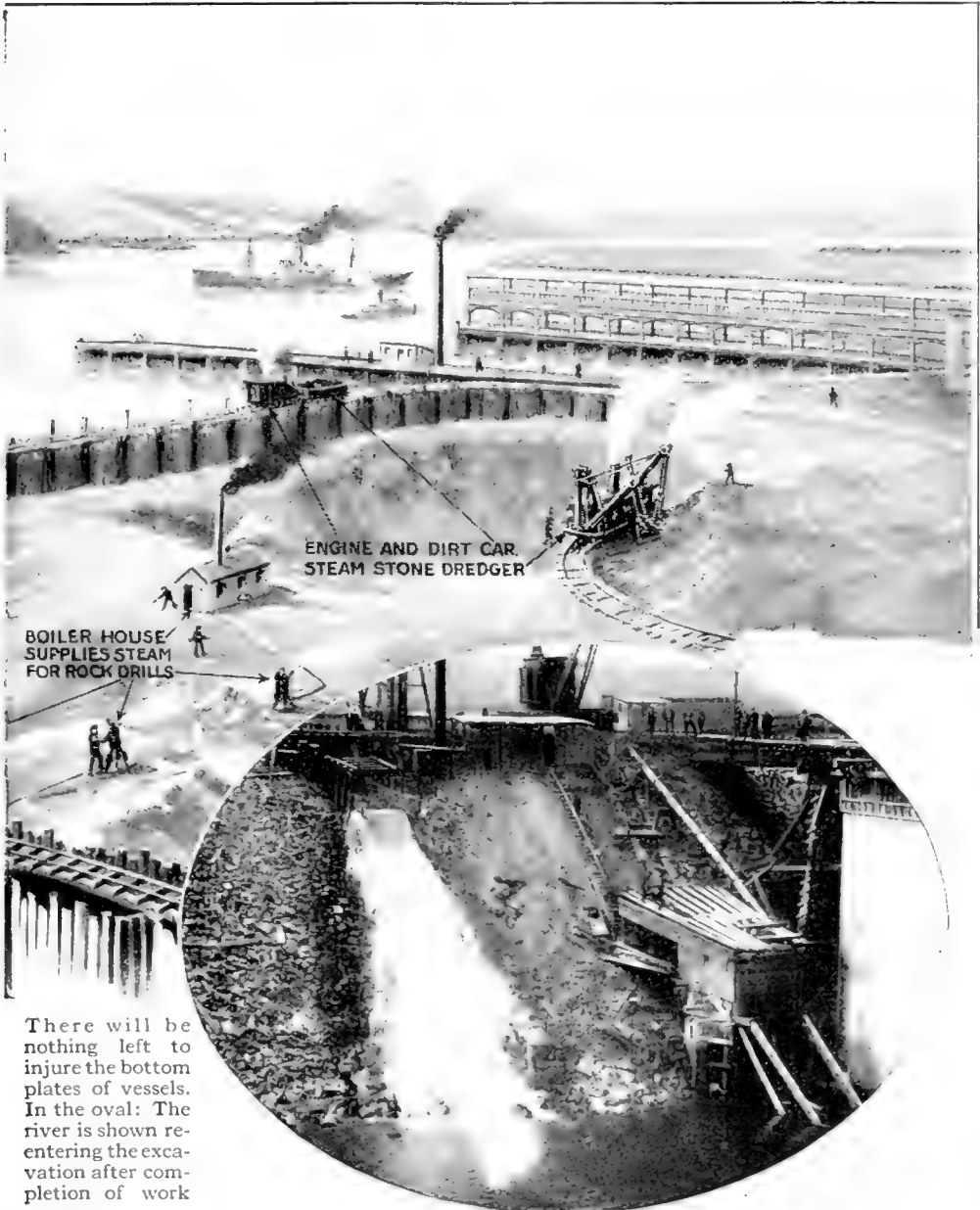

There will be nothing left to injure the bottom plates of vessels. In the oval: The river is shown re-entering the excavation after completion of work

the Black Rock Dam, near Buffalo, it was necessary to have three fifteen-inch wrecking pumps in continual operation. To-day the drained area on the east side of the Hudson is noisy with an incessant chorus of drills, with the occasional counterpoint of a heavy blast. When the carving of the slips or waterways is completed, there will be no obstructions to injure the bottom plates of

vessels floating there. The piers will be one thousand and fifty feet in length, and one hundred and fifty feet in width. One interesting feature about the piers is that only a small part of their length will be supported by actual contact with the underlying rock. The remainder will float, and the anchorage will be the grip which the piles have on the semi-fluid mud of the river bottom.

# Some New Ideas Which Automobilists Are Employing

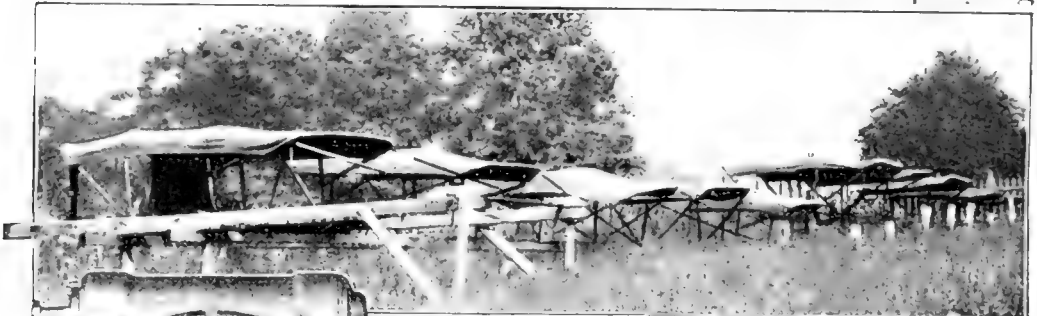

Above, automobile tops of leather substitute tested for a year in an open field

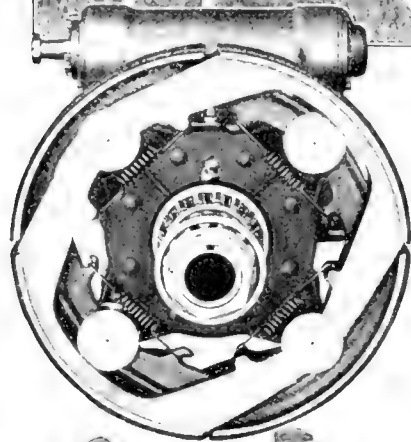

At left, a five-ton worm-driven motor-truck axle which has a pressed steel housing

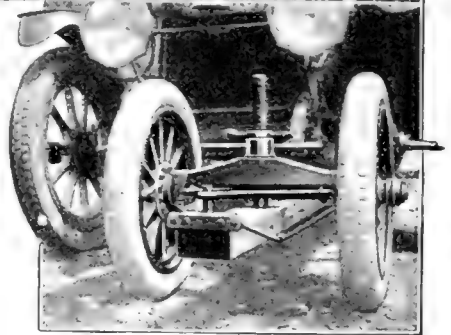

Above, a special apparatus of long beams on tires designed to aid in towing disabled cars

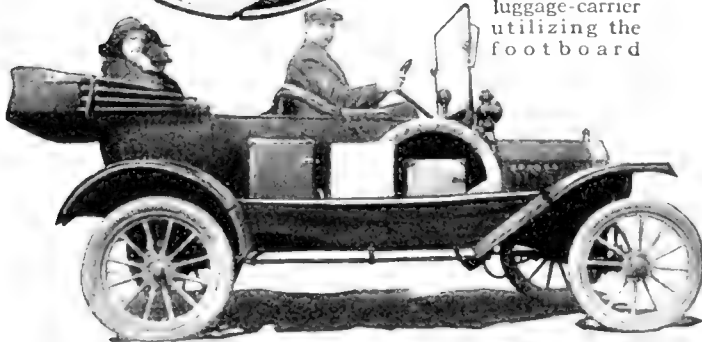

Below, a new automobile luggage-carrier utilizing the foot board

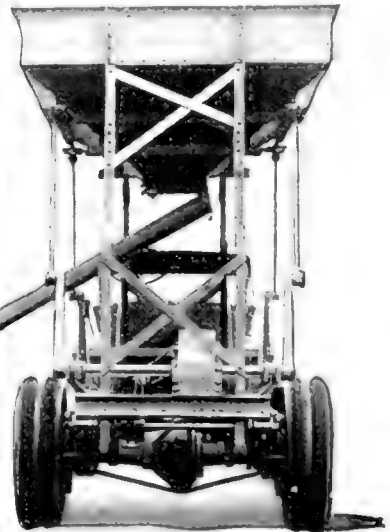

Above: Four jointed steel arms raise this steel coal body ten feet in thirty seconds

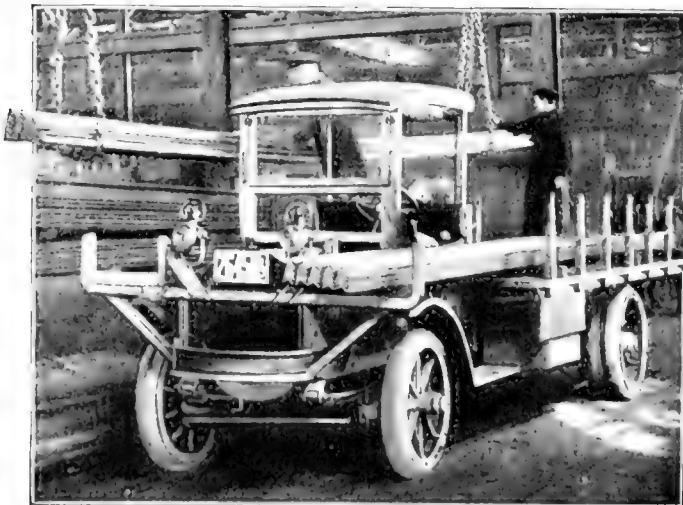

At left: A narrow driver's cab and two steel U-shaped supports front and back enable this truck to carry twenty-foot steel beams

# to Make of the Motor-Truck a Mechanical Day Laborer

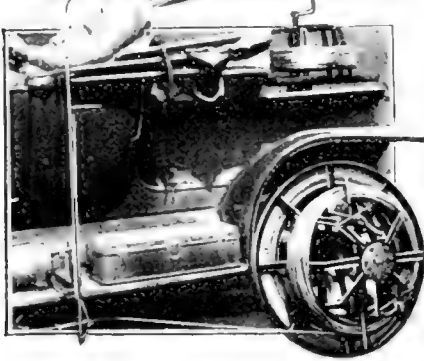
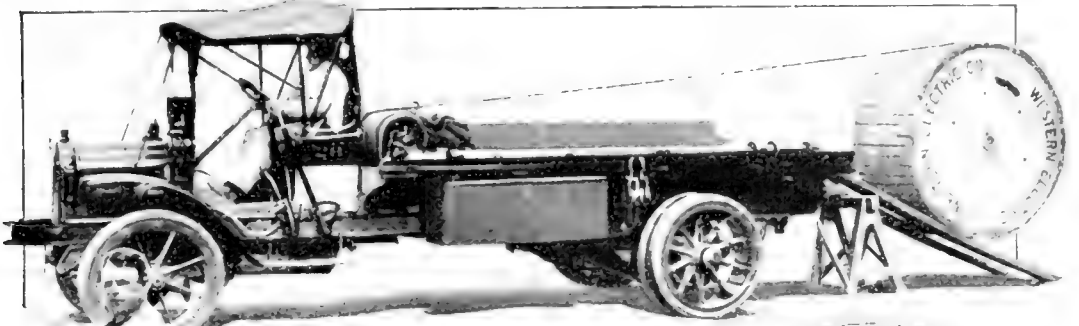

Above: A reel which may be attached to the rear wheel of any automobile intended for the use of telephone companies, can roll up a half mile of wire in less than ten minutes

Above: Unloading a five-ton reel of telephone cable without manual labor by using an ordinary drum-winch placed directly aft of the driver's seat. It is driven by power from the truck  
 At right: A lock designed to control both the spark and throttle levers on automobiles

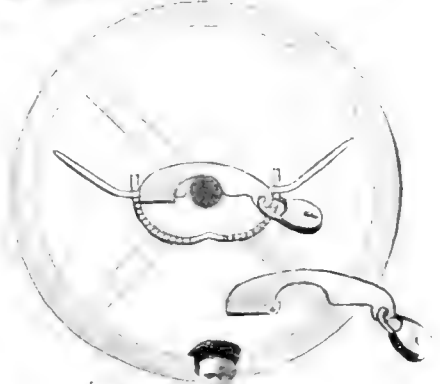

At right: The seven-year-old son of a New York dock superintendent runs a six-foot electric automobile.



The mechanical loader is run by electric or gasoline motor

Above: A self-propelled motor-truck and wagon loader. The hinged bucket framework section may be raised or lowered without exertion

# Inventions Which Improve the Motor-Truck and Make

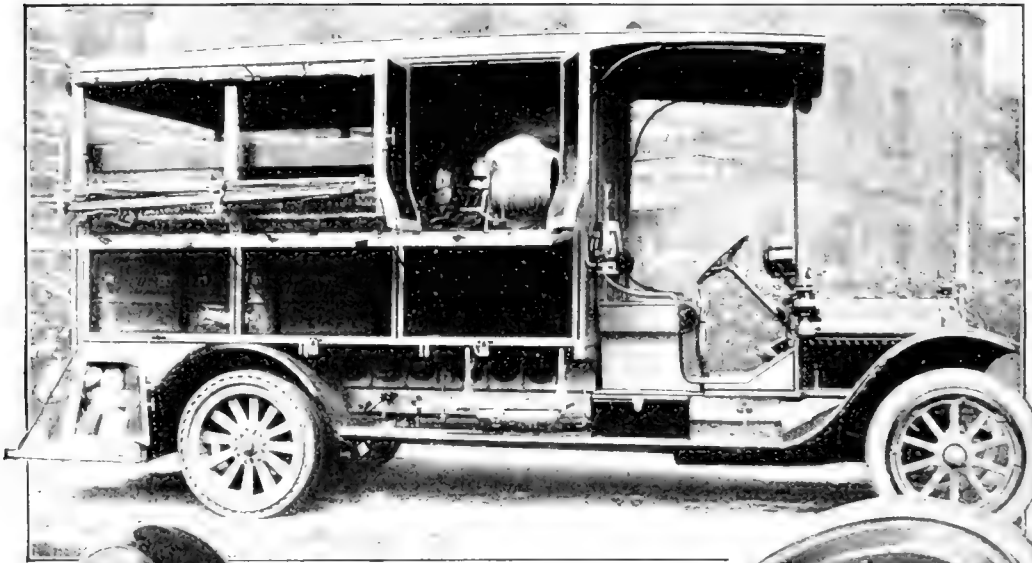

Above, a truck for mine rescue work equipped with a wonderful variety of scientific paraphernalia, including a complete telephone system

At right, a hydraulic pressed steel wheel used on trucks in war service. Its strength is rated higher than that of any other type of wheel made

At left, an adjustable two-bar extension rear axle for a motor-cycle sidecar

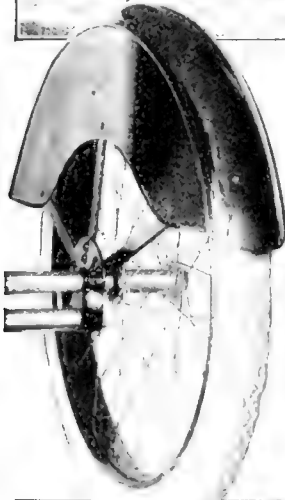

Above: In Long Beach, California, an immense disk is painted in the center of each street intersection as a guide to automobiles and vehicles

At left, a removable motor-truck headlight carried only at night. During the day valves fastened to the tube are closed and the headlight is removed from its U-shaped stand in front

# Motoring Even More Pleasurable and Less Expensive

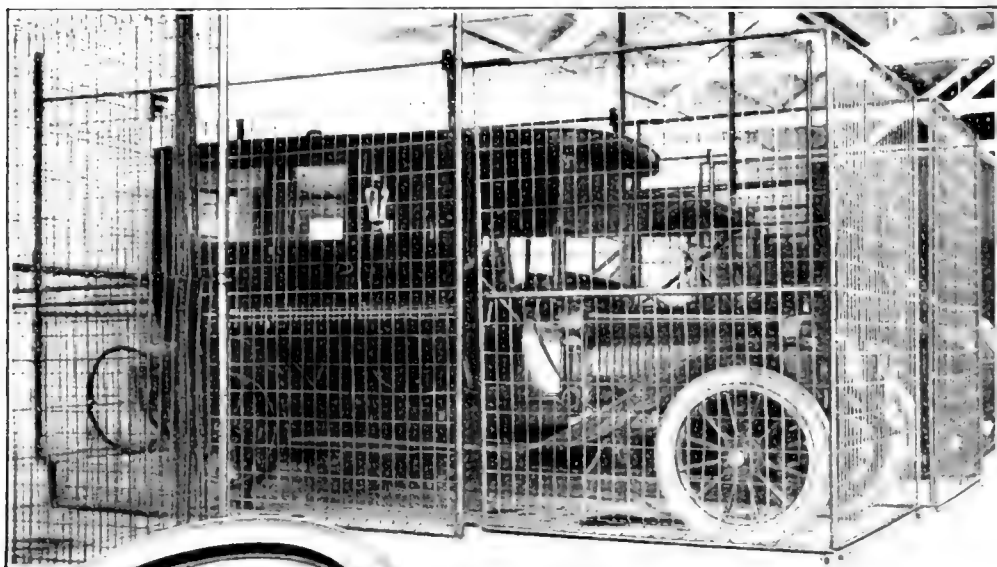

Above: Cars are stored in steel cages in Los Angeles instead of being parked in chalked-off spaces

At left: An anti-rust band for tires consists of a band of black rubber on the inside

At right: A plug constructed as two units which can be removed without tool or wrench

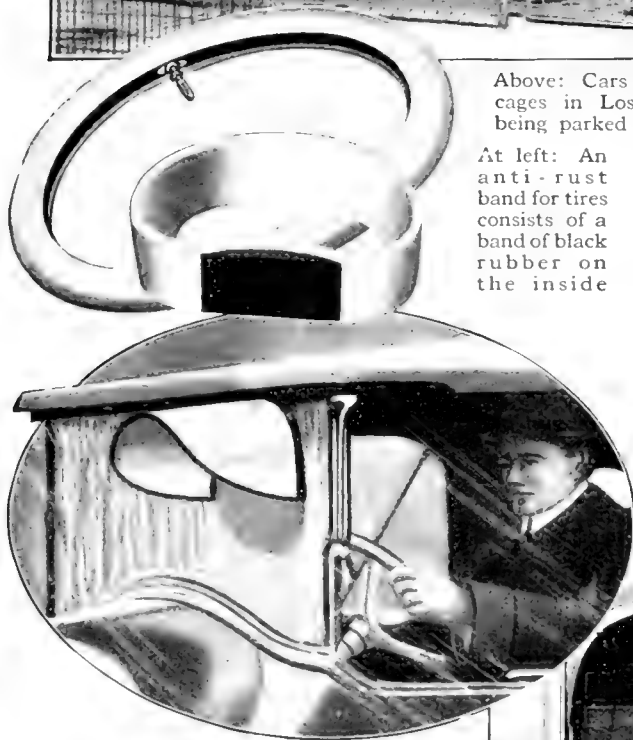

Above: A rain-shield designed to protect the driver from the rain while providing an opening for a good view

At right: Overhead view of a new type of roadster body which provides plenty of elbow-room for the driver

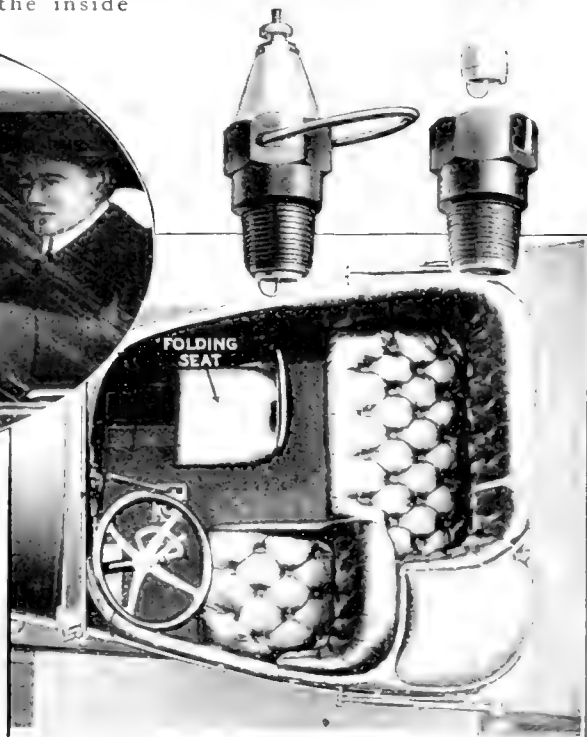



### Road-Construction Facts by the Wayside

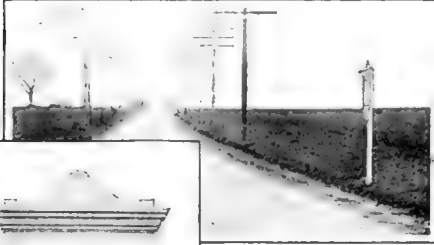

A bulletin board placed beside a stretch of road which is being built or repaired gives the passer-by the method of construction and the reasons why it was adopted. The bulletin also tells the taxpayer what he is paying for

**G**OOD roads enter so largely into the affairs of the average man in this age of the automobile that a popular step was taken when road-construction facts were given to the public in a new and striking manner. The bulletin board illustrated is in use in and about Philadelphia, where the Chief of the Bureau of Highways, William H. Connell, is telling the taxpayer just what he is paying for in roads.

The bulletin tells all the details of materials and construction in non-technical language. The foundation course is described, as is the surface course, and the surface finish. Then the method of mixing the materials for the surface course is described, and the materials are enumerated.

### "Troubleshooting" at Night with the Aid of a Searchlight

**T**HE "troubleshooters" of the Far West—the linemen who brave the fiercest weather to keep the telephone line open at all times—have already been immortalized in story. It is now the turn of the "troubleshooter" of the big Eastern cities to get his name into the latest fiction as a hero in disguise.

Keeping telephone lines repaired is one of the most difficult of jobs. There is not a day but the superintendent of construction in every big telephone company sends out his corps of linemen.

In Pennsylvania the largest telephone company has a "troubleshooter's" equipment which is the last word in efficiency. A big motor-truck enables the men to get to the particular scene of trouble in a minimum of time. When the call comes in the dead of night the truck aids the linemen with its searchlight which is thrown directly upon the spot. With its aid he does the work easily.



The telephone lineman making a quick repair under the beam of a searchlight which is mounted on an emergency truck



# A Motor-Truck That Equals Two

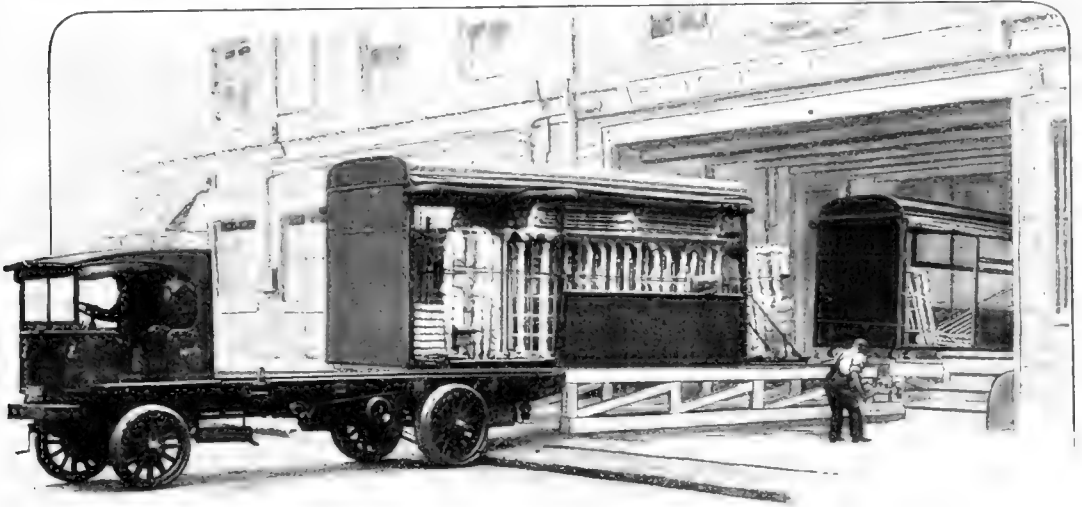

Two detachable bodies, resting on rollers, are pulled on and off the chassis over an inclined platform. While the truck is delivering the contents of one the other is being loaded

**T**WO demountable bodies and a novel inclined platform have enabled a motor-truck owned by an Eastern manufacturer of beds to do the work of two vehicles. It was very necessary when preparing to transport the beds over the city streets or country roads to pack them into the truck with the greatest care in order to avoid scratching the enamel or other highly polished surfaces during transit, and thus detracting from their value. At first this packing and loading took so much time that the truck was standing idle for long periods. Then the truck owner devised the loading and unloading scheme which is shown in the accompanying sketch.

The apparatus consists of two demountable bodies resting on rollers, so that they can be pulled on and off the truck chassis, and an inclined platform upon which the bodies are withdrawn for loading.

On the top of the platform which consists merely of boards carried on supporting frames, are two sets of wedges, with their thick ends at the center and their tapering ends at the ends of the platform. The tops of these wedges are fitted with channel irons to form troughs in which the rollers on the bottoms of the truck-

bodies are constrained to run when the bodies are removed.

The truck arrives at the plant of the manufacturer with its empty body and backs up to the platform. The empty body is pulled off the truck chassis and upon the inclined wedges by means of a rope hooked to the rear end and run over two pulleys to a drum under the platform and operated by means of gears and a small hand-crank. The body is left in this position to be loaded with beds from the main loading-platform, which is directly alongside of the platform on which the bodies of the truck are placed.

The truck then backs up to the other end of the platform, and the loaded body, which has been filled with orders while the goods in the empty body just placed were being delivered, is pushed down the inclined wedge upon the truck in the reverse manner. By the time this load is delivered, the first body is again loaded and ready to be pulled upon the truck after it has again returned. Thus the idle loading time of the truck is practically eliminated.

When on the truck and ready for a trip the body is held in place securely by four folding hasps, two on each side.

# Solving New York's Freight Problem

By Herbert Francis Sherwood



A typical scene along the water-front of New York and Brooklyn. Freight cars, lighters, steamers unload their freight, regardless of system, regardless of expense. Every ton of miscellaneous freight carries as much of a charge for terminal handling as it does for rail or water transportation, an average of about seventy cents per ton. New York has by far the crudest and least economical means of freight handling of any great modern city

**N**ATURE has made in New York Harbor the problem of a cheap manner of transferring goods between land and water and the transportation lines and factories, warehouses and stores difficult of solution. This year the complex method of handling freight has been further complicated through the scarcity of ships and the congestion of the railroad terminals in consequence.

It is difficult to realize that if the shoreline of the waters included within the limits of the port of New York was untangled and connected so that it ran more or less directly toward one point of the compass, and a railroad were laid upon it, it would take the Twentieth Century Limited, traveling at an average speed of fifty miles an hour, fifteen and one-half hours to traverse it. The

number of miles of waterfront is 771. Of this total, 578 miles are in New York city, the remainder being the New Jersey shore extending along the Hudson River from the upper end of the city around the Lower Bay to the lighthouse and artillery proving grounds on the extremity of Sandy Hook. Unfortunately, there is no railroad along the busiest part of this great shore front. This is what distinguishes the problem of handling freight in New York Harbor from that of other ports. One commission after another has looked at the problem and found it like a mountain front. They have tried to scale it, but this has proved more difficult than the ascent of Mt. McKinley.

In the old days, when masters of ships had an opportunity to show how to dock a vessel with every sail flying, and

did it with an artistry that was at once a source of envy and a joy to behold, the fact that New York city was on an island did not count so much against it. Waterways were the chief highways. And New York had the advantage over every other port on the Atlantic coast in that one of its highways to the interior was a waterway that cut across the Appalachian system at sea level. It was in the days following the opening of the Erie Canal, giving it access to the Great Lakes and the heart of the continent, that it leaped ahead in the race for commerce.

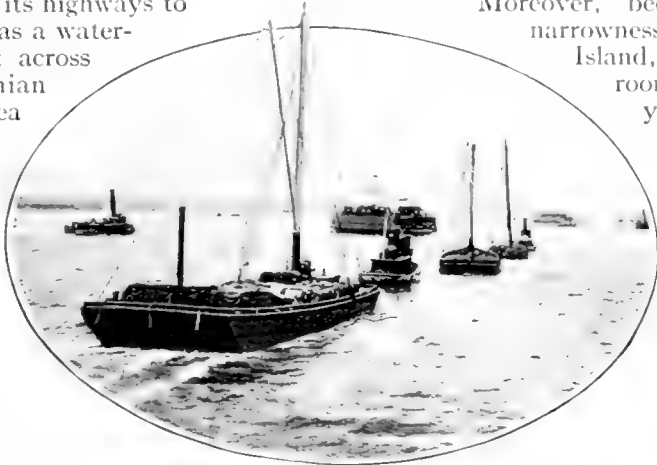

Much of New York city's freight is transferred to lighters after having arrived on ships, and is then loaded upon carts. Millions are annually thus wasted in useless handling

with the interior waterways in getting the products of the rich farms of the Mississippi Valley to the seaboard. So now, New York is handicapped by the fact that it is surrounded by waterways the most important of which cannot be bridged for the transportation of freight.

Moreover, because of the narrowness of Manhattan Island, there is little room for freight yards, and little opportunity for getting cars onto the piers alongside the steamships. Having little space on a horizontal plane, the pressure has shot the inhabitants up into the air, and down

The railroad, however, has demonstrated that it can compete successfully

into holes in the ground, where they work, where they travel and where they live.



New York's methods of handling freight at its terminals is discreditably to the largest city of the western hemisphere. Freight is handled and re-handled, transferred from ships to lighters, and from lighters to carts. If we could cut the cost of handling the freight of the country by only one cent per ton, it would mean a saving of \$20,000,000 each year. Every ton of package freight in the United States bears a charge of 74 cents for terminal handling

Notwithstanding the handicap, however, nearly half of the foreign commerce of the United States passes the Ambrose Channel and Scotland Lightships swinging at the entrance of the two pathways into the harbor. It is not until one stops to realize that New York's foreign commerce is equal to that of Portland, Me., Boston, Providence, Philadelphia, Baltimore, Norfolk, Newport News, Wilmington, N. C., Charleston, Savannah, Jacksonville, Tampa, Mobile, New Orleans, Galveston, San Francisco, Portland, Ore., Seattle and Tacoma combined, that one can appraise that statement at its worth. Despite the fact that all raw material must be transported many miles to its factories, New York City is the greatest manufacturing community in the United States. At least one-tenth of all the manufactured goods produced in this country are fabricated within its borders. It has been asserted that the city is the food market for 15,000,000 people. And yet only one of the great trunk lines can run its freight trains directly into Manhattan.

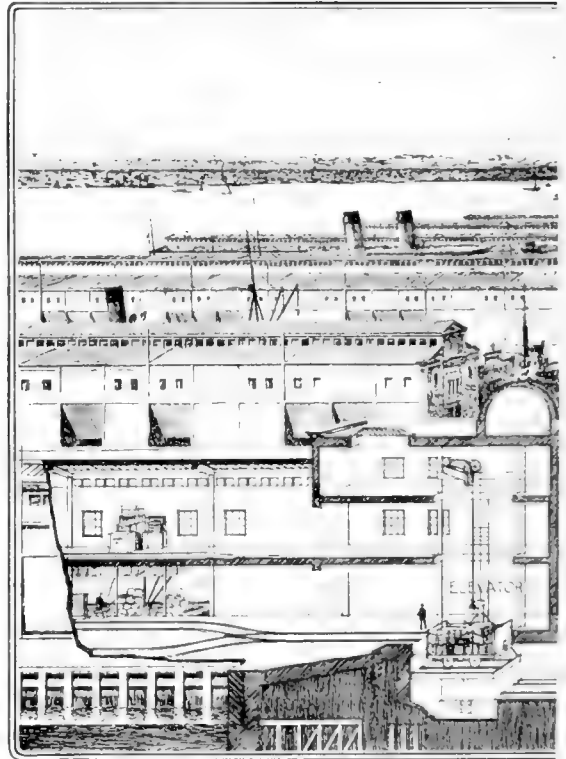

The Wilgus freight subway for New York city is to extend throughout the city. Branches will

Ranking first in some respects among the four chief ports of the world, its waters are probably busier than those of any other port, for a large proportion of its freight must be distributed and collected upon them. Therein it resembles Venice. One Saturday afternoon the writer stood for an hour on the Battery Wall watching the

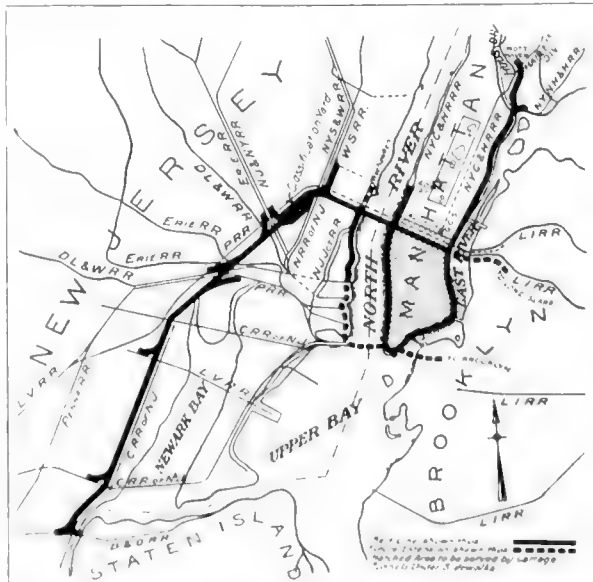

Instead of loading and unloading freight several times during transit from New Jersey to New York city, Mr. Wilgus would send it by rail under the river directly to its final destination

various types of vessels ranging from great ocean-liners to snorting grimy motor-boats moving over the ever-shifting surface. In the course of that time, 183 passed on one side or the other, an average of more than three per minute. There is probably no busier bit of water in the world. The last report of the New York State Commission to Investigate Port

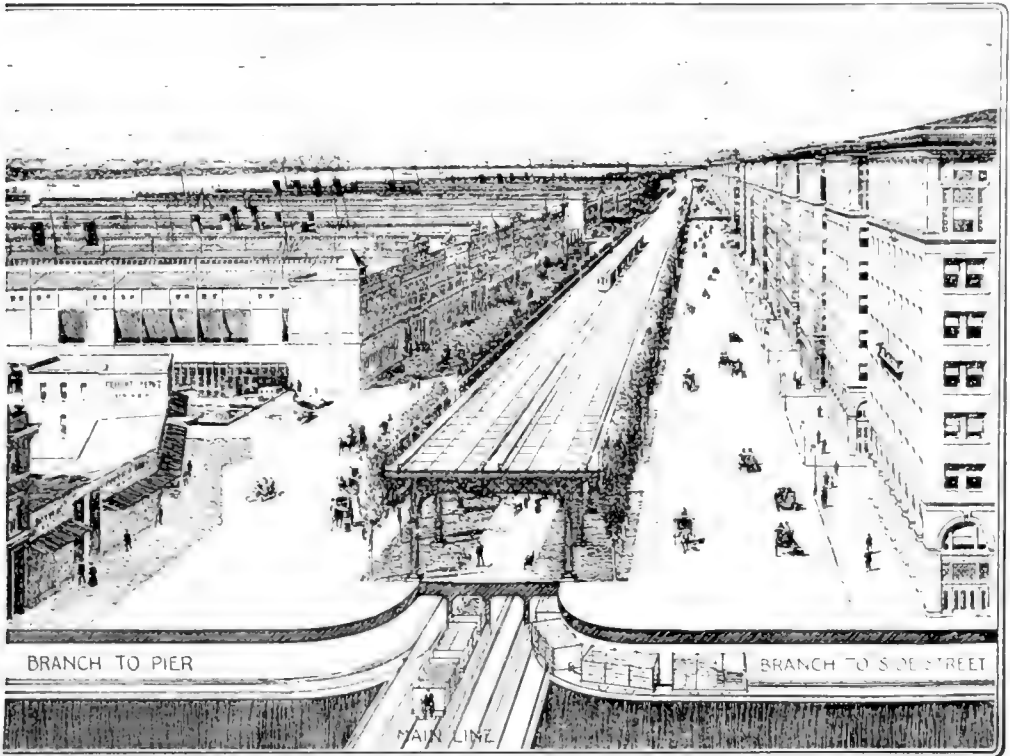

run beneath the piers of the great ocean steamships. Whole freight cars will be raised and lowered by elevators, and branches will run through the side streets to the consignees

Conditions in New York Harbor, which is dated August, 1915, points out that the total amount of goods moved on the waters of New York Harbor, other than that on ferry boats, in the year 1906 was 113,969,355 tons. No one knows what it was worth, but one student of harbor conditions guessed that it would take approximately ten billion dollars to meet the invoices.

One-quarter of the ferry boats of the United States were to be found in New York Harbor at that time. There were also 5,289 unrigged boats for moving heavy freight around the bay and adjoining waters. One-half the tremendous volume of products was transported on lighters. A considerable part of the equipment for handling freight is owned by the railroad companies that have no tracks on Manhattan and cannot lay them down on the island.

In most communities it is practicable to run tracks alongside the piers, factories and warehouses. It has not been so in New York City in the past. The

manufacturers and merchants have been obliged to rely upon trucks to get their goods from the railroads and ships to their places of manufacture, storage and trade.

This has always caused great congestion along the waterfront, particularly that of Manhattan. Here the railroads compete with the steamship companies for space to land their freight. The railroad companies do this by establishing depots on piers, alongside which they bring great carfloats, floating switches they might be called. So general is the use of carfloats that it has been said that every morning the terminal yards of the great trunk lines in Jersey City, Hoboken and Weehawken are detached from New Jersey and drawn across to New York City, being returned again at nightfall.

Trucking, however, in New York City is costly owing to the high expense attached to housing and feeding horses and the length of time required to get a load to or from the waterfront because

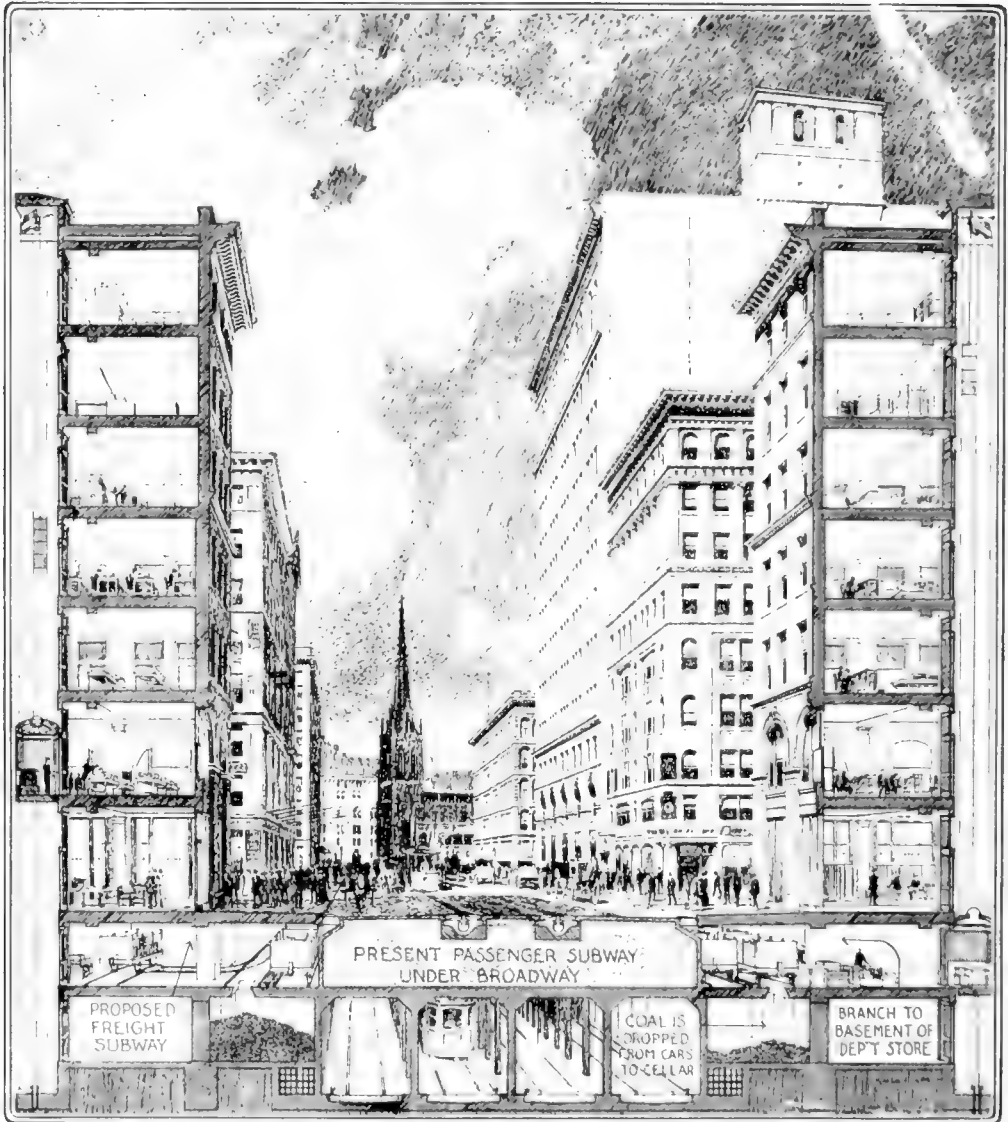

New York city wastes millions in cartage. If the Wilgus plan is adopted, a freight subway will run through New York city, paralleling the present passenger subway in some sections, for the purpose of transporting the freight underground and through tunnels under the Hudson River to its destination, thus saving the additional expense of re-transference

of the congestion at that point. It has been stated that it cost more to haul a ton of freight from a railroad terminal in Jersey City to a warehouse in Manhattan than from Pittsburg to the seaboard. R. A. C. Smith, Commissioner of Docks and Ferries, has suggested that the time required to load the trucks might be reduced by constructing pier-sheds in such a way as to permit the trucks to go out upon

them at one side, enter in order through a series of doors, and return in a regulated procession. William J. Wilgus, a former vice-president of the New York Central Railroad, has submitted to the public Service Commission a project for transshipping freight to smaller cars at a great terminal yard to be established on the Hackensack Meadows. These cars were to be operated by electricity through tunnels under the Hudson River

to Manhattan, where they would be distributed to the consignees by means of small subways constructed under the sidewalk. They were to be unloaded directly upon the basement platforms of the consignees and reloaded. The recent development of the motor-truck, which makes possible the transportation of larger loads than in the case of horse-drawn trucks, has suggested another solution of the problem. It is proposed that a standardized chassis be designed to carry a standardized van-body, which can be carried on one of these subway cars from the classification yards on the Meadows. This would be placed on a chassis at the terminus in Manhattan and run to the destination of its contents. It can be returned filled with other goods just as railroad cars are shifted from one region to another. A crane would be used to transfer the great box from the motor chassis to the car and back again.

The ideal solution would be a series of terminals similar to the Bush Terminal circling the harbor in Brooklyn, Staten Island and New Jersey and connecting with a belt-line railroad by car-floats and tracks. The belt-line railroad would run around the rear of Jersey City and Hoboken and be operated in the interest of all the intersecting railroads. At the intersections would be transfer and classification depots. This would make it unnecessary for the railroads to maintain independent stations in every borough and reduce the cost of delivery. In addition, this belt-line road might maintain a truck delivery system just as the railroads do in London and the express companies do here. Already a proposition to establish a terminal at Bayonne similar to the Bush Terminal is being discussed. It might become the transfer point and terminus of such a belt-line railroad.

#### How Do You Sit?

A CHAIR is like a shoe, doctors say nowadays. It is comfortable only when it fits the body. And they also say that the ordinary chair does not fit the body, no matter how much upholstery or padding it may have.

So they have gone to work and built a chair that fits the body to a "T".

See that hump in the back in the accompanying illustration? The purpose of this is to fit into the bend of the back in such a way as to afford support to the back and thus allow the muscles to relax and rest.

In the case of the ordinary chair the hump is not in the chair, but in the person sitting down. His shoulders stoop forward, his body slumps down, the abdomen is thrown forward and the abdominal organs get out of place. The new chair corrects this defect



The hump in the chair fits the bend in the back in such a way as to afford perfect support



# Ten Millions to Save Four Miles

**I**N the Canadian Rocky Mountains is a giant mass of rock, towering 8,540 feet and known as Mount McDonald. It lies on the route of the Canadian Pacific Railway. Between Mount McDonald on the right and Mount Tupper on the left, the road enters what is known as Rogers Pass. To reach the other side of the Rockies, the trains had to climb two long spiral loops. If they were to tunnel through the mountains the route would be shortened only about four miles, but the grades would be reduced, with the result that much time would be saved as well as wear and tear on rolling stock. Besides, the expense and danger of maintaining and operating four and one-half miles of snowsheds would also be eliminated. Considering these factors, as well as the amazing increase in traffic, an increase which involved double-tracking, it was decided to tunnel Mount McDonald.

Two years were spent by engineers in seeking the most favorable location for a bore. A spot was discovered best suited for an undertaking in civil engineering which compares favorably with the wonderful tunneling that has been done in the Swiss Alps.

The Selkirk Tunnel, as it has been called, is of interest because of the unusual method employed in the boring. In all such work it is important that the excavated material shall be removed with the greatest facility; that the work under way shall not be impeded; and that provision shall be made for carrying high-pressure air pipes for the drills, water pipes and ventilating suction pipes. And so it was decided to dig two tunnels—one of them a "pioneer tunnel," in engineering parlance, the sole function of which is to provide an outlet for the excavated material.

If you will study the pictures appearing on the next page, you will see at once how the pioneer tunnel fulfils its purpose. At the east end the pioneer tunnel was located fifty feet to the north of the center line of the main tunnel and at the west end, fifty feet to the south of it. First of all, an upper center "heading" was dug. In other words, a rather shal-

low channel was dug along the line of the main tunnel. After this center heading had been made, the work of digging out the main tunnel to its full dimensions proceeded. The material excavated was hauled to the pioneer tunnel, which runs parallel with the main tunnel, through cross-cuts, following the course shown by the arrows in the diagram on the following page.

After being conveyed through the pioneer tunnel, it was carried back again to the main tunnel, but, of course, at a point far removed from the scene of operations. After that, it was hauled out on a trestle over standard-gage tracks through the main tunnel and dumped into regular railway cars. The excavation was, of course, all done by steam shovels of one and a half cubic capacity, which means that at a single scoop, a shovel would dig out about an ordinary wagonload of dirt and rock. The dirt cars were hauled to the mouth of the tunnel by standard-gage compressed-air locomotives.

The tunnel, which is five miles long, lowers the summit of the line by five hundred and fifty-two feet. Its estimated cost is over ten million dollars.

The tunnel is twenty-nine feet wide and twenty-three feet high and follows a straight line under Mount McDonald, emerging in the Beaver Valley beyond at a point about one thousand feet below the present railroad route.

The eastern end is directly below Hermit, a station just east of Rogers Pass. The highest point reached in the tunnel is three thousand seven hundred and ninety-five feet below the summit of Mount McDonald peak. Up to the interior summit the passage through the tunnel has a grade of one per cent. The climb for the tunnel is made by the railroad on the most northerly station on its route. The tunnel route originally discovered by the engineers was six miles long, but this was gradually decreased to conform to the five-mile tunnel. The pass gets its name from Major A. B. Rogers, who penetrated the fastnesses of the Selkirks in 1861 and discovered this opening through the range.

# Tunneling Through the Canadian Rockies



One of the intersections of the pioneer tunnel with the main tunnel. Horses were used to haul the muck cars to the point where they were dumped into railroad cars. From this point to the mouth of the tunnel standard-gauge compressed-air locomotives were employed

A view of the entrance to the tunnel under Mount McDonald. It emerges at a point in the Bear Valley about one thousand feet below the present railroad route

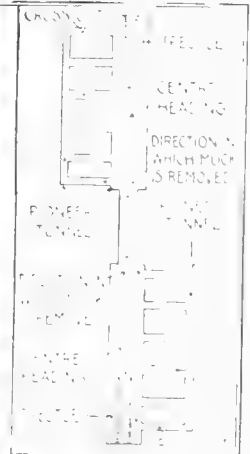
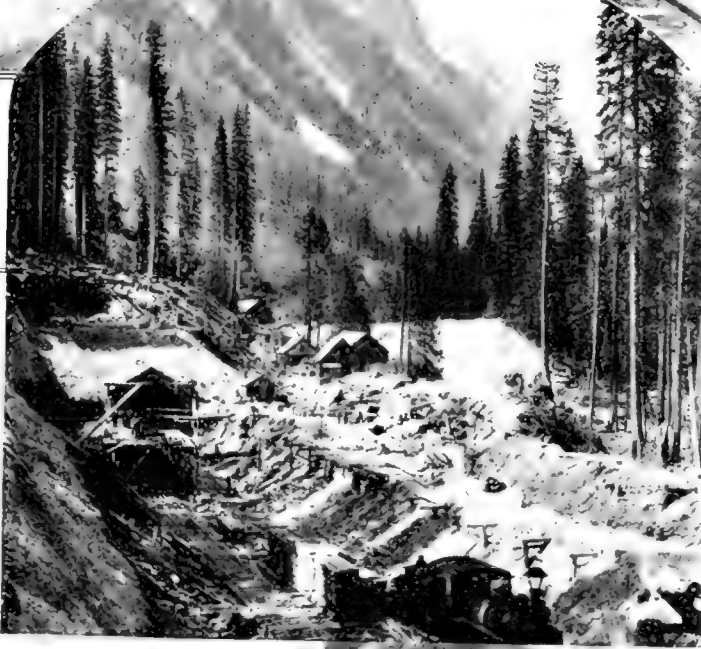

In the lower picture the mountain is shown sliced away to reveal the pioneer and main tunnels, as well as the laterals connecting the two. The material excavated was hauled through the pioneer tunnel and then through the main tunnel as indicated by the arrows in the diagram on the right

# Bucking a Wooden Football Line

**P**UTTING your shoulder to the wheel of opposition and developing strength and power from the struggle is an ethical procedure in the generally accepted meaning of the words. But football players have not only reduced the axiom to practise but have even manufactured a sturdy opponent which is equal in weight and resistance to seven human beings.

Heavy oak planks ten feet long, one foot wide and four inches thick are put together in pairs and laid seven feet apart, with one end each rounded like the runner of a sled. Cross-beams of similar material are then fastened in place until the whole resembles the framework of a sled. Seven planks three feet long and one wide are placed in an upright position along the back of the framework and braced by heavy timbers to the cross beams. The uprights are then heavily tufted.

When all this is done you have a "bucking" machine that

is used to train football players in the gridiron sport. This apparatus is really for the line men to use, and its weight is approximately that of seven football warriors who constitute the line of an opposing eleven. Against the tufted uprights seven players hurl themselves with as much force as if a game were actually on, and the sledge-like mechanism is pushed over the turf sections of the field.

At the opening of the season, when the players are somewhat tender, the weight of the apparatus is lessened. As the men become hardened to the demands of the sport, weight is increased by the addition of several timbers and sometimes a heavy stone. The "bucker" has proven a valuable aid to both trainers and players.

It has been found that the men trained to it are prepared in considerably less time than would have been required without its use.

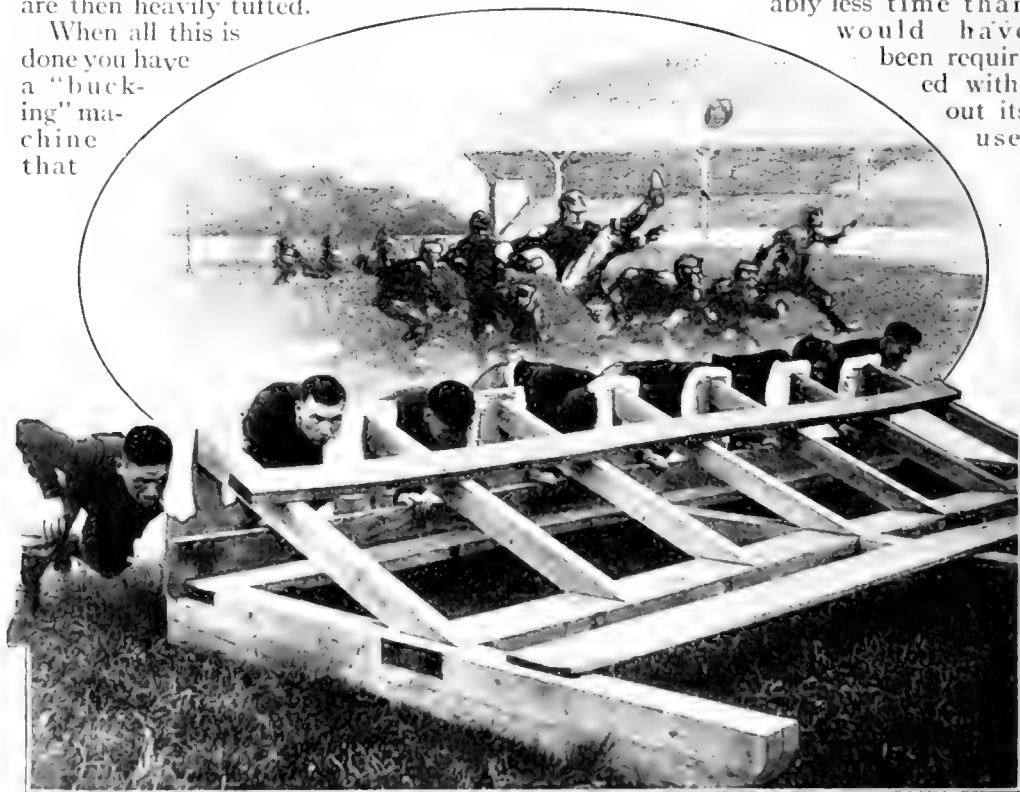

The weight of the apparatus is approximately that of the seven men who constitute the line of the opposing eleven. As the season advances the weight is gradually increased

# The Czar of the Power-House

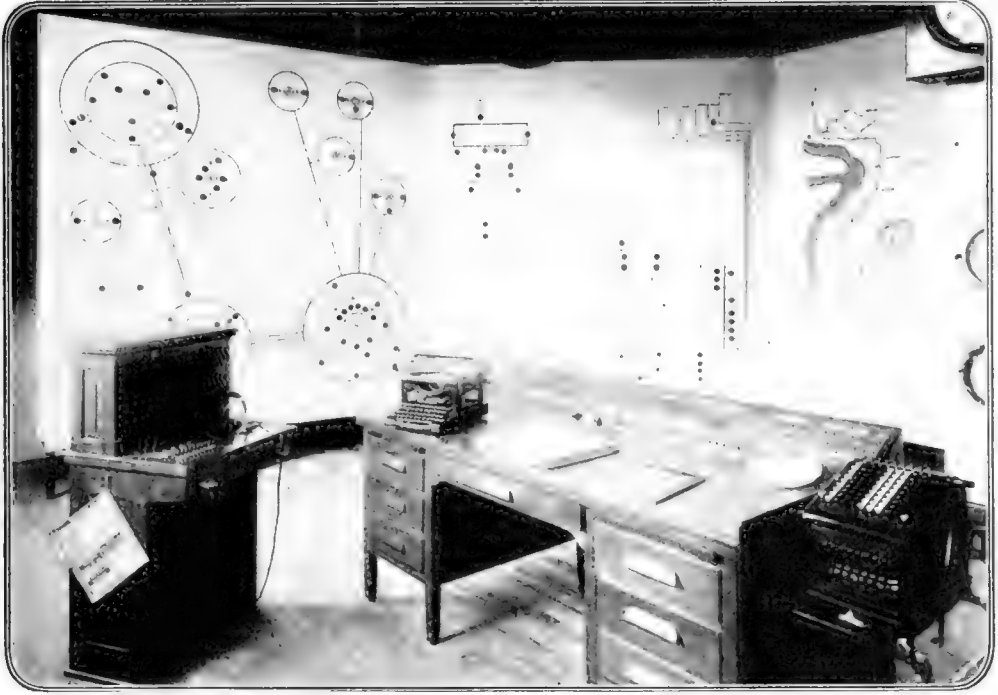

By the mere pushing of a few buttons on his desk the man who controls the delivery of current from a great power-house can stop all street cars, put out all lights and shut down hundreds of businesses dependent upon the power

**T**HE man who controls the outgoing current from a central power-house is a Czar whose domain may cover all territory within a radius of one hundred to five hundred miles of the station. By the mere pushing of a few buttons on his desk he can stop all street-car systems and every interurban railroad. He can put out every light, cool every electric flatiron, cause mills to shut down—in fact deaden every activity in his territory dependent upon electric power. The men down in the great power plants await his call. At a signal from him they let loose or restrain huge turbines—machines in some cases each capable of putting forth ten or twelve thousand horsepower, more sometimes than half a state uses in all its industrial activities. Outside men patrol the long transmission lines. If trouble develops in any one district an automatic signaling system apprises the dispatcher of the fact, and by means of telephones at his elbow he

mobilizes the men. All energies are bent toward making immediate repairs.

If a lightning and rain storm is approaching, a wireless system acquaints him of its coming. Lightning is the dispatcher's principal enemy. Often the wireless system tells of approaching storms, even though the sky be clear.

Only in times of emergency does the load-dispatcher exert his full powers. Huge central stations are often under contract to supply uninterrupted service. Sometimes they incur heavy penalties if contracts are not carried out. The dispatcher is simply a man made in part responsible for the smooth working of the system. When the street cars, elevateds, and subways are taxed to the utmost in carrying home-going crowds, he is the man who has had extra boilers put in service and extra engines started in order to carry the suddenly increased load. So, too, he prepares for the many lights of evening.

### Sampling the Drinks for an Entire Large City



Cincinnati's water is tested three times a day. If it is not pure this man makes it so

**I**N the employ of the good city of Cincinnati is a doughty knight of the sack who attends to the sampling of the water which, after all, forms the basic drink of the city.

The water to be taken internally by Cincinnati is tested at least three times a day, in ordinary times, and oftener in seasons of high water and the like.

Regulation tests are made for both alkalinity and turbidity. After the analysis has been made there is dumped into the water sufficient quantity of iron to form ferric-hydroxide (a jelly-like

substance), which settles out whatever there may be of impurity remaining.

That is to say, the water taken from the Ohio River by Cincinnati is first led into settling-basins, where sixty to sixty-five per cent. of the mud is removed by simple sedimentation. The water is then run to the filtration plants, where the sulphate of iron solution and the lime-water are added. These chemicals react and yield the ferric-hydroxide, which is insoluble in water. As a result, the greater portion of all remaining impurity settles in the coagulating basins, as they are called. By this process perhaps thirty per cent of the original amount of mud and the like is removed.

The remaining five per cent to ten per cent deposited is then filtered out by the sand-filter and the water is then ready to drink.

### What Is the Leaning Tower of Pisa Compared with This?

**A** CHURCH in a little Connecticut town has become a famous landmark in the state as a result of a severe storm. A few years ago the spire was blown off and in falling made a half turn and dived through the roof, driving its point through the shingles. There it has remained ever since, and as the photograph shows, it presents a decidedly "misplaced" appearance.



The spire was blown off the steeple and its sharp end pierced the roof and stuck

# Bathing in Your Trunk

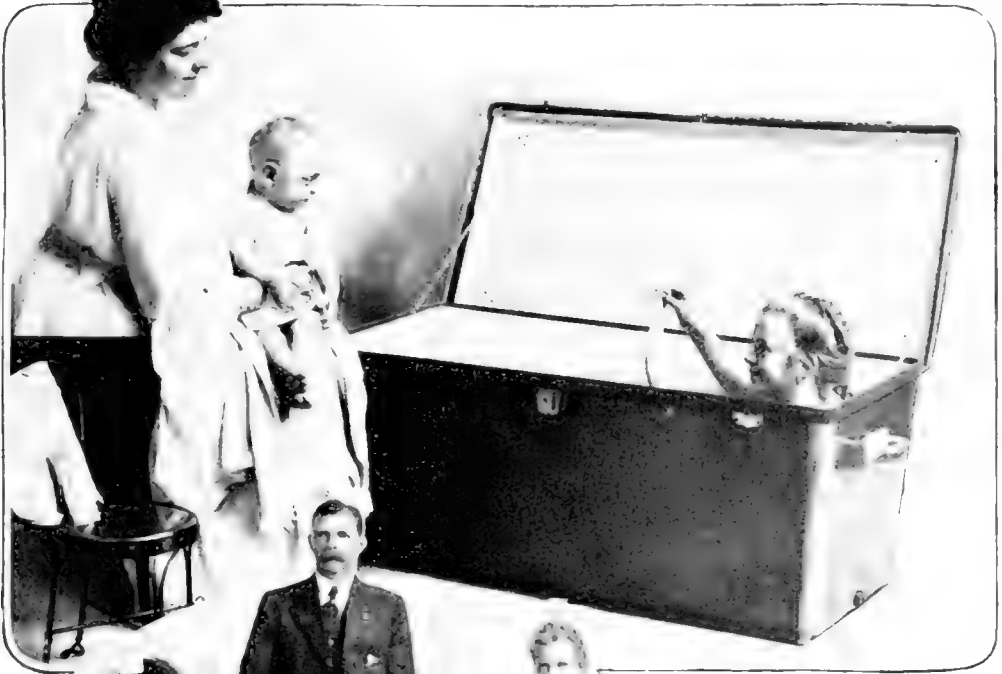

Above, the metal combination trunk which serves as a bathtub for the family. It is made of sheet metal, enameled inside and is damp-proof for clothing



It is light in weight, yet strong enough to withstand the rough handling which baggage men would give it. It makes a clean storage place for laundry

**A** COMBINATION trunk, laundry basket and bathtub is the novel invention of Ole C. and Hannah Lee, Ronan, Montana. The trunk is made of sheet metal, enameled inside and outside to adapt it for use as a bathtub or laundry tub, and it is also provided with an outlet at the bottom, to which a hose can readily be attached to draw off the water. Besides giving very satisfactory service as a bathtub, the trunk is a clean storage place for laundry.

That an article representing an investment of \$15.00, the cost of an ordinary trunk, should be useful only as a container for clothing when traveling, struck the inventor as a waste of capital. What is more, the ordinary trunk does not protect the contents from dampness. This led to the invention of a metal combination trunk, which, while comparatively light in weight, is strong enough to stand the rough handling trunks are apt to receive at the hands of baggage men. Although the inventor has made his bath trunk in only one size, it can be made in other sizes.

# Housekeeping Made Easy

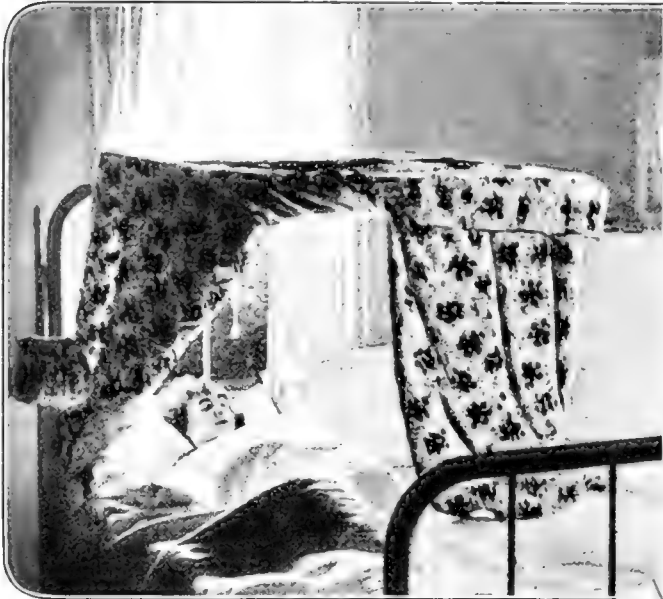

This is an adjustable curtain sleeping tent supported by rods fastened to the window casing, making an inexpensive and easily attached substitute for a sleeping porch



The frame supporting this sewing basket is collapsible so that it may be folded up and tucked away

Below: A strainer for gravies and sauces. It has a heavy wire attachment for pressing out the lumps



On the right: A strainer with extension rods to fit the rims of various vessels



Below: A cutter for decorating fresh fruits in attractive designs for the table



Small rubber-covered wheels clamped to the rockers will convert any ordinary rocking-chair into a wheel-chair

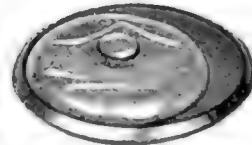

Above: A medicine-cover and tray. The cover fits any ordinary glass and the tray holds the bottles and protects the table from stain



On the right is a double fork, useful in removing potatoes or other vegetables from the pot or oven without breaking them



# Housekeeping Made Easy

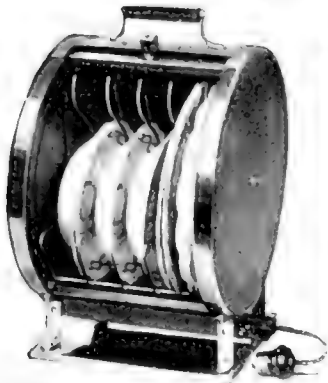

Above, an electric plate-warmer which connects with any light socket. When closed it will retain the heat for hours without current

Below, a device for serving condensed milk or syrups from the original cans. The spout has a sharp end which perforates the can



A neat and attractive flower-box for the window garden has a tube for watering and a perforated false bottom



This new type of kitchen cabinet incorporates a stove and a refrigerator, both of which are completely shut from view when not in use

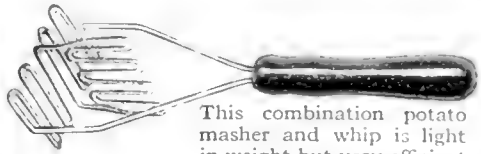

This combination potato masher and whip is light in weight but very efficient

Two more or less unpleasant tasks may be quickly accomplished with this combined pot-scraper and fish-scaler



This kitchen sink has an attachment on each side which provides extra space whenever desired

# The Wiles of the Automobile Thief

**T**HERE is a department in the bureau of New York police which does nothing all the year around but round up automobile thieves. When an automobile is stolen, the case is immediately referred to the "Stolen Automobile Squad."

The professional automobile thief has the air and appearance of a polished gentleman. He is of the resourceful "Raffles" type. He dresses perfectly, and his com-

If the ignition system is locked the thieves quickly install one of their own temporarily

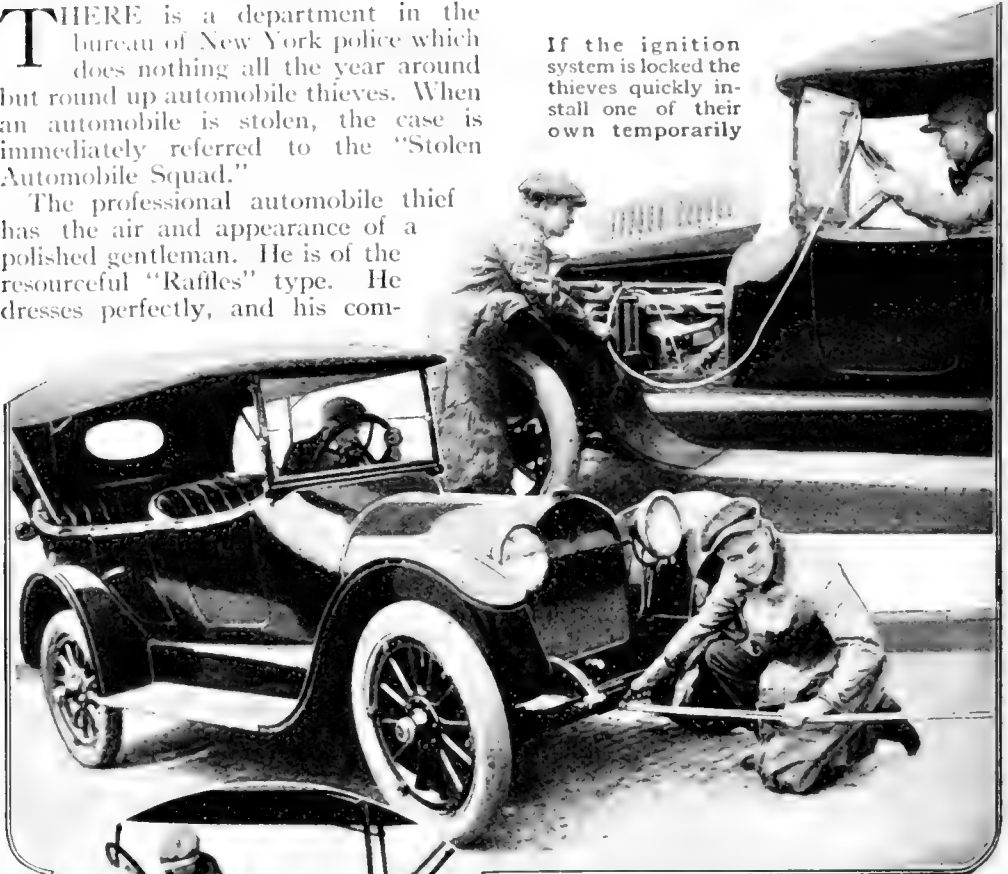

Sometimes the empty automobile is simply hitched to a truck and towed away

Such obstacles as chain-locks are inconsequential trifles to the professional thief. He simply cuts them with nippers



climbs in with careless ease, starts the engine and drives away. When he is two or three blocks away, his confederates will climb in, and the car will be driven hastily into some deserted street.

mand of English is great enough to deceive the most suspicious of policemen. His ingenuity seems to be boundless.

It may be that an automobile thief has stolen a car under your very nose! He is the last man you would suspect. He approaches an empty automobile,

The first step is to disguise the car. Name-plates, usually from another state, are hastily clamped over the original plates. The hood is lifted, the serial number of the engine is filed or ground away, and new numbers are stamped in their place. The numbered plate on the running-board is removed and another substituted. Impedimenta, such as mir-

rors, clocks, etc., are carefully removed. The car, thus altered, is driven away. If a suspicious traffic policeman should

the gasoline tank is locked, it is a simple matter to syphon enough gasoline from a beer pail into the carburetor for a short run into a different locality.

One band of enterprising automobile thieves eventually captured in Kentucky stole forty-seven Ford cars in New York City within six months. They specialized on doctors' cars, because they realized that when a doctor paid a call he usually left his car standing unguarded for a half hour at least, unless he happened to have a chauffeur or a guest in his car, in which case, of course, it was safe from the thieves.

Many manufacturers of high-priced automobiles stamp in some inconspicuous place identification numbers upon a permanent, immovable steel part and then paint over the numbers. When doubt arises as to the ownership of the car, the paint is scraped off and the owner's identity revealed instantly by consulting the sales record of the manufacturer or selling agent.



The thieves substitute new license plates and a new serial number on the engine to satisfy the suspicious traffic police

stop the car, the courteous gentlemen who are riding in it will present an identification card to correspond with the new license plates. They point to the serial number on the engine. Is it not different from that of the stolen car? And so, they ride away safely, unless the officer is unusually astute and persistent.

Sometimes your thief drives in a motor-truck alongside an empty automobile, hitches the two vehicles together, and tows the automobile away as if it were disabled. Such obstacles as chain-locks

are inconsequential trifles. Sharp wire-cutters end the usefulness of all small chains.

Again, if the ignition system of a car is locked, the knights of the road quickly install one of their own temporarily. If

#### A New Gasoline-Motor-Driven Road Roller

THE old-fashioned steam-roller, with its heat, its smoke and its noise, has at last been supplanted by

the roller which is shown in the illustration, which may be started at a moment's notice

and has no fire to kindle, no steam to get up and no coal to carry. It is driven by a gasoline motor. When not actually working, the motor is shut off, whereas with the steam type, steam must be kept up. The

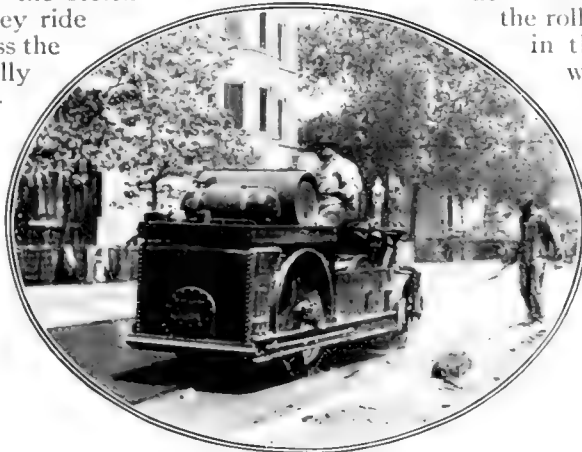

A gasoline motor has eliminated the upright boiler, the steam and the noise of the street-roller of the older types

elimination of the upright steam boiler allows the driver a better view of his work and reduces the weight of the roller, without, however, reducing the pressure, besides insuring a more steady movement of the rollers.

# A Magician Among the Fishes

IT IS doubtless true that there are no mermaids in the sea and no Neptune with crown and flowing locks, but the species of life that do exist there are in many ways equally as interesting as the mythological folk. Take the little puffer fish, for example, which has attracted the attention of scientists from earliest times on account of its shrewd habit of defending itself by inflation. The moment it scents danger in the form of a larger fish, searching for a dinner, it instantly distends itself with water until it becomes almost spherical in shape, so that no ordinary fish could swallow it. Director H. C. Townsend of the New York Aquarium, placed a few good-sized scup, or porgies, in a tank which contained a dozen young puffers about two inches in length, which the hungry scup attacked at once. Instantly the baby puffers inflated themselves and became almost globular in form, so that the larger fish were unable to do more than knock them about like toy balloons

too large to be swallowed, and on which they could get no hold whatever.

The puffers are of many species, many of them reaching a length of about two feet, most of the larger kinds being found only in the large rivers of the tropics.

When caught in nets and dragged ashore they inflate themselves with air just as with water when in the sea, making a slight sucking sound until their skins are as tight as drums. They remain inflated until thrown back into the water and can be knocked about on the beach like rubber balls without a particle of air escaping. Even when thrown back into the water they may float

upside down for a time before assuming their normal shape.

A valve in the throat is the means by which this choice, edible fish is changed into an unmanageable balloon and back again when its fright is over.

The valve seems to be controlled entirely by the volition of the fish, unless the fright which the fish experiences upon



Above: The puffer in normal shape. There are numerous species, varying in size

Left: When inflated the puffers can be knocked about on the beach like balls



A candle suspended from a wire shines through the stretched skin as through thin oiled paper making a bizarre lantern

sighting danger causes the valve to open spasmodically, thus allowing an inrush of water or air. Sometimes the puffers die while still inflated, and they remain in that shape, being often driven ashore by the wind and dried on the beach by the sun.

The Japanese make lanterns of them when they find them in that condition. They cut out the back and suspend a candle from a wire into the fish body.



The appearance of the yareta from a distance is that of a huge recumbent sheep

### The Strange Vegetable of Peru That Resembles a Sheep

**A** CURIOUS plant growing in Peru is known to the native as "Yareta" or "vegetable sheep." It grows abundantly among rocks at high altitudes along the Andes of Bolivia and Peru, where it constitutes a conspicuous feature in the landscape because of its peculiar manner of developing the so-called "polster," or cushion formation.

The "yareta" forms hillocks or small mounds often three feet high and sometimes several feet in diameter. Moreover, the entire mound is made up of a single plant, not of a colony of individuals, and it attains this enormous size and extreme compactness by a process of repeated branching, so that the ultimate branches are closely crowded and the outer surface is continuous.

The flowers of the "yareta" are very thin, only about one-eighth of an inch long, and are borne in small clusters near the tips of the branches. The fruit resembles a miniature caraway seed. The natives use the plant as fuel.



A fragment of yareta showing the sponge-like construction of the interior in which resinous substance is secreted

as shown in one of the accompanying illustrations which are published by courtesy of the New York Zoological Society. The light shows as brightly through the stretched skin as through a piece of oiled paper.

Some of the puffers are covered with spines which become rigidly erect when the skin is inflated. This species is also known as the sea porcupine. All the puffers have hard, strong beaks like parrots, which are well adapted for crushing the shells of the crabs and mollusks upon which they live. At certain times of the year, probably during the months that contain no "R," they are considered poisonous in the tropics, so much so that the gall of a Japanese species was formerly used to poison arrows.



A nearby radiator supplies the steam through a hose to the apparatus in use

#### Using the Steam Radiator to Remove Wall-Paper

TO provide a convenient means for utilizing live steam in order to make easy the removal of old wall-paper preliminary to redecorating, Julius Matzke, of Indianapolis, Indiana, has invented an apparatus which is said to meet all demands. The object of his invention, in addition to applying steam for the removal of the paper, is to localize the application of the steam so as to avoid injury to adjacent woodwork or other accessories, and to exterminate all germ and insect life on the wall.

The steam is supplied from a radiator and is led through a flexible hose to a hood-shaped head or steam-applying chamber. At the end of the hose, as it

enters the hood, are numerous perforations which are staggered to distribute the steam as thoroughly as possible. A valve at the outer end of the pipe provides a conveniently located means for controlling the steam supply to the head. The hood may be detached and the nozzle used when working close to woodwork and for discharging steam into crevices to kill vermin.

#### A New Electric Cloth-Cutter for Small Shops

TO meet the demand of small tailor shops a cloth-cutter which cuts one, two, or three layers of cloth at a time has been designed. It consists of a compact and light machine which can be operated from the ordinary lighting circuit. It has been placed on the market by a western manufacturer.

Although electric cloth-cutters have been in use in large clothing shops for sometime, most of the machines heretofore employed have been made only in large sizes suitable for cutting twenty thicknesses of cloth at one time. These were not suitable for the small shop.

The new cutter is particularly adapted for the cutting of heavy cloth such as is used for overcoatings and the like.

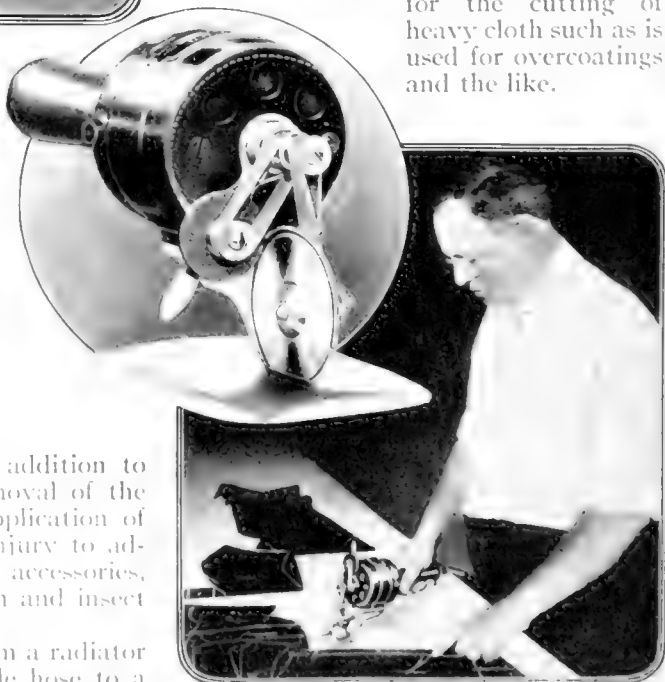

The cutter consists of a motor, a circular cutting-disk and an emery sharpening-wheel

# Dropping to Safety from a Fire

SUCCESSFUL experiments were made recently with a new Danish fire-escape at the main fire-station of Charlottenburg, which is a suburb of Berlin. The apparatus comprises a crane which can be swung out of the window, a rope and a brake to regulate the speed of descent. The brake consists of a pair of cylinders filled with oil. They act like the cylinders of an automatic door-closer and are not influenced perceptibly by differences in the weight of passengers.

The apparatus can be secured to any window. An iron plate is securely bolted to the window-frame or fastened to the stonework. When a fire breaks out the apparatus is swung out of the window on the iron plate. The entire weight is only about twenty-two pounds.

To escape from a burning building, you first put on a leather belt and slip a safety hook on the wire rope of the apparatus into a ring on the belt. Then you mount the window sill, swing out the crane, and step into space. When you reach the ground, you slip off the belt. A coiled spring, which has been placed under tension as the result of your drop, winds up the rope automatically and is ready for the next passenger in line.

The speed of the drop is about three and one-half feet a second. The spring winds up the rope at the rate of seventy feet a second.

Experts are inclined to regard the new means of escape as the most efficacious yet employed. Besides being swifter than the old method it is con-



To escape from a burning building, a belt is put on, a safety-hook is adjusted and a swift descent is made through space

In the detail illustration the crane of the apparatus is shown and the brake cylinders which regulate the speed of descent. A coiled spring just above the belt rewinds the rope automatically

sidered safer and the exit is apt to be less frenzied than down a stairway.



The Electrical Scrub-Woman—  
Brainless but Efficient



The machine is fitted with four to eight brushes the pressure on which is regulated

IT IS only a matter of time before the scrub-woman will give way to the scrubbing-machine, just as the horse has given way to the automobile.

Scrubbing by hand requires physical strength and is slow and sloppy. There is nothing slow or sloppy about the mechanical scrubber.

The machine is fitted with four to eight brushes, which are regulated by an interlocking spider, so that the amount of pressure on the brushes may be adjusted according to the condition of the floor. The scouring soap-powder is carried in a can containing an agitator to stir the powder when the machine is in operation. Hence the powder is sprinkled evenly and not in cakes and lumps. The

can is only four inches from the floor. Hand-sprinkled powder must drop about three feet.

The water-sprinkler is so placed that it applies the correct amount of water directly to the powder. The powder and water are immediately set in motion by the brushes.

After the floor is thoroughly scrubbed the dirty water is removed by means of a squeegee with a suction-pump so placed that when the squeegee gathers water the pump forces it from the floor to a can.

An electric scrubbing-machine with two operators will scrub three thousand square feet of floor in an hour.

Trundling Your Washing-Machine  
on Wheels

AMONG the most recent labor-saving devices for the woman in the home is a set of casters designed for use on washing-machines. Equipped with these the washing-machine is as easily trundled as a go-cart or other light vehicle.



When the machine has been wheeled into the position required for work the casters are detached by means of tilting the tub first on one side, thus dismantling

those on that side, and then tilting it on the other side to release the two opposite.

A lever and notch are employed. Tilt the machine and the lever slips out of the notch. Lower the machine with a quick motion and the lever will slip over the notch so that the machine will rest firmly on its feet. When the machine is tilted and then lowered slowly the lever will slip into the notch, and the machine will once more be on wheels.



The casters are easily detached by tilting the machine

Small Electric Pump for Draining  
Seepage from a Cellar

**H**OUSEHOLDERS living on low ground are continually troubled with water seeping into the cellar. The condition is seldom easily remedied, for not even concrete floors and walls are successful in stopping the water's inroads. For cellars so afflicted a new electric seepage pump is proving highly effective. The idea is to make a tank-like hole in one corner of the cellar into which the water can seep in preference to working its way up through the concrete of the floor.

The motor used with this device has a vertical shaft, and is located on the cellar floor. The shaft is connected with a centrifugal pump under water in the hole beneath. The contrivance is entirely automatic in operation. A float sets the motor going when water has collected to a certain height and shuts off the current when a sufficient amount has been pumped out. The hole, being at a much lower point than the surrounding cellar floor, serves as a Mecca for all the ground-water beneath, leaving the floor dry and sanitary.

Pumping Up His Interest  
in Your Wares

**T**HERE is no business man who can withstand a working model. With this fact as a basis for a sales campaign,

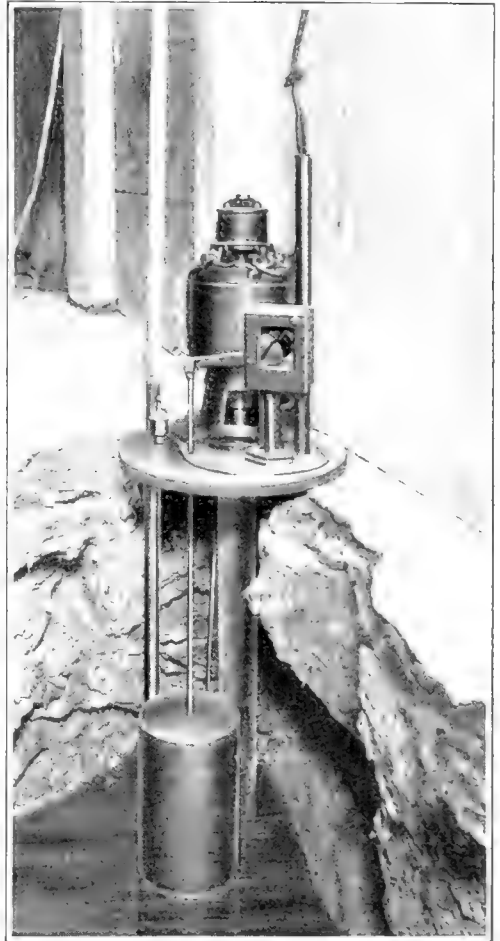

The motor has a vertical shaft connected with a centrifugal pump under the water in the hole beneath the floor

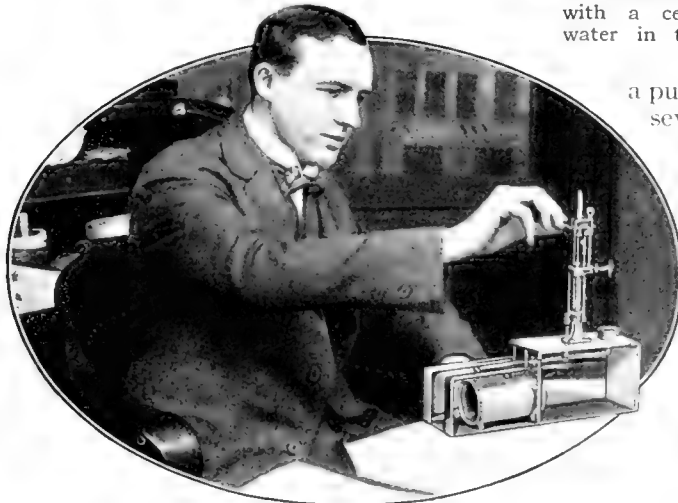

Many a sale is made by arousing the grown-up boy's interest in a mechanical toy, getting him to watch how it works

a pump company has turned out several models of their gasoline tanks for use by their salesmen.

This picture illustrates a salesman demonstrating a pump to a prospect. The tank is filled with water, and by operating a lever the water is pumped out and a complete demonstration made.

The usual plan of relying on arguments to convince the prospect does not compare in results with the model.

### Playing Ball with a Revolving Fan as a Target

A NEW game has been invented which makes it extremely difficult for an experienced ball-thrower to display his ability. Indeed, luck vies equally with marksmanship in running up a score. For instance, the player throws a ball at the target, which is made up of paddles or fingers held yieldingly in either active or inactive position. If the ball passes through and does not touch the paddles it rolls gently down the alley and into one of the high-score openings, generally one on the outside. On the other hand, if the ball hits the paddles it is deflected against the wire cage with such force that it rolls with considerable speed down the alley and thus into one of the low-score openings. However, there is nothing to prevent a poor shot from scoring high, which means that the inexperienced ball-thrower has an equal chance with the experienced. A novel feature of the device is that the score is constantly before the eyes and that the balls are returned to the thrower as fast as they are thrown. Of course, a person who can throw a ball with considerable force has a better chance of running up a high score than the person who cannot throw hard. The ball has to be thrown rather than tossed at the revolving fan, to make a score.

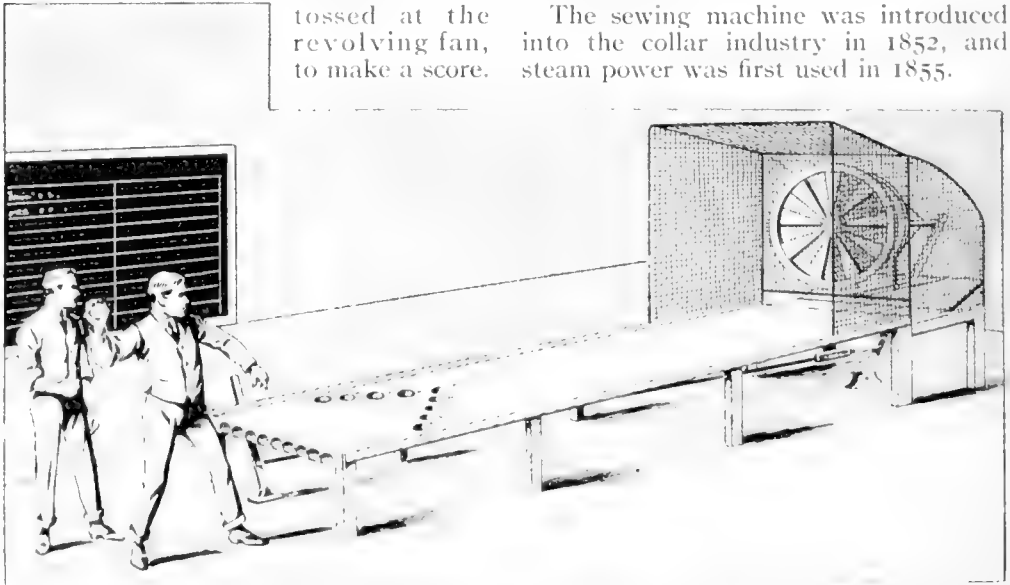

The target is a fan composed of paddles and the object of the game is to throw a ball through the openings between them while the fan is revolving, without touching them

### Where the Linen Collar Started and Who Started It

THE wife of a Troy, N. Y., blacksmith is said to have been the first person to have made separate collars for men's shirts. This happened in 1825 and men have been suffering ever since. Outside of inventing the separate collar this woman did the family washing.

Accordingly she set herself to work making separate collars for her husband's shirts and then made enough to sell outside the home. This innovation attracted the attention of the Rev. Ebenezer Brown, a retired Methodist minister, and he, with the aid of the women of his family, went about selling collars. This was in 1829.

All the work on these early collars was done by hand, for the sewing machine had not yet been invented. In those days not more than a dozen collars a day were sold. Their name—"string collars"—was especially appropriate, for they were tied around the neck with a string of tape attached to each end of the collar. Except the bands, the first separate collars were generally all linen and of two thicknesses, although some were faced with cotton cloth. They were slightly stiffened and had high points extending above the chin on either side.

The sewing machine was introduced into the collar industry in 1852, and steam power was first used in 1855.

# Motoring on Roller-Skates

IF we had wheels on our feet, something like the wings on Mercury's heels, would we "get there" much more quickly? Walking is admittedly an energy-consuming method of locomotion. A man's legs weigh forty or fifty pounds apiece, and the sheer labor of shifting them one ahead of the other means a considerable expen-

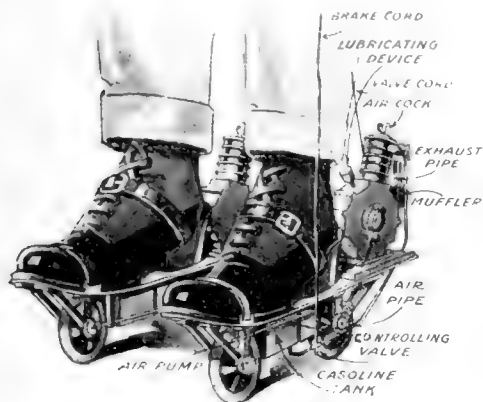

Fig. 1. The driving agency is a small gasoline engine in the rear of each skate

diture of energy. Placing the same weight on the respective pedals of a bicycle will convey a man much farther. Wheeled locomotion has time and again demonstrated itself to be the most efficient method of getting over the ground.

This leads up to the subject of roller-skates. Why is it they are not more in use? A man on skates can propel himself half a block with a stroke or two. Is there any reason why their use should be confined to children? Is it the dignity of the thing? Assuredly Americans never stop for dignity if a new contrivance will get them where they want to go faster than has before been possible.

Scores of different kinds of roller-skates have been invented. All the inventors appear to be striving toward an unattainable ideal, and each approaches the problem from a different angle. The ordinary four-wheeled skate such as children use is too tame for most inventors. They would make the vehicle

self-propelling, apparently believing that therein lies the secret of the ultimate roller-skate.

The easiest way to make a skate propel itself is to put something on it to do the propelling. In some forms the driving agency is a small gasoline engine; mounted at the rear. (Figs. 1 and 7.) The machines have shaft or chain-drive and are complete as to detail, some of them resembling miniature Ford automobiles. They even have a gasoline tank under the instep and heel-part of the skate, the heel-brace being shaped somewhat like a miniature automobile seat. The great difficulty with the gasoline engines which must be employed is that the cylinders are so small. It is hard to get an explosive mixture into

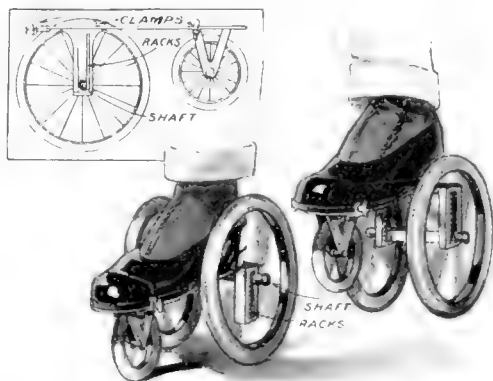

Fig. 2. A sort of pantograph-motion causes the rear wheel of this skate to revolve

them and to discharge the burnt gases. Consequently the engines are inoperative three-fourths of the time. Other self-propelled skates have been made along similar lines, but driven by an electric motor. These have, on the whole, been more successful.

The second general type is also self-propelling, but utilizes the weight of the rider in some way to supply the driving agency. The methods of doing this are legion. Most of them depend on the fact that a man raises his foot in taking a step forward. In swinging his weight onto this foot he exerts downward pressure on his heel. The skate shown in

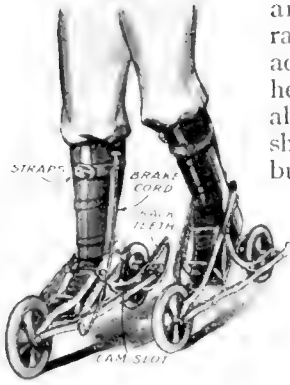

Fig. 3. The spring on rear wheel must be wound up at each stroke

Fig. 10 has a rack-and-pinion arrangement to take advantage of this heel pressure. So also has the one shown in Fig. 3, but with greater complication, since a spring on the rear wheel must be wound up at each stroke. The spring keeps unwinding and is thus supposed to

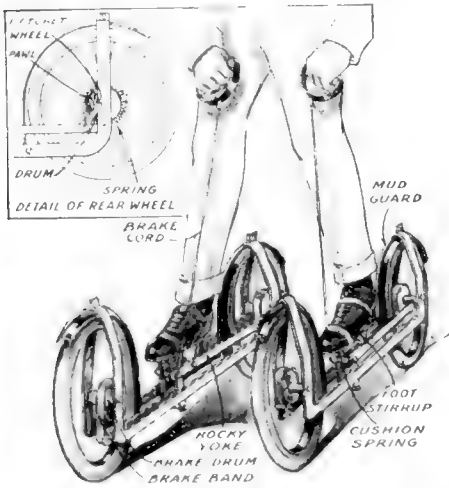

Fig. 4. Large wheels, a low center of gravity and a brake on the front wheel

propel the rider at a steady gait. In the machine of Fig. 8 the rider's foot must incline at an angle with each forward stroke. The heel in descending makes a pawl catch in a cogwheel and thus drives the skate.

It is impossible to get more power out of a machine than you put into it. The inventions discussed fail to allow for that fact.

The skate shown in Fig. 2 uses a sort of pantograph-motion. In descending the foot moves a lever downward. This engages a ratchet arrangement inside the hub and causes the rear wheel to revolve, thus driving the skater forward at a proportionate rate of speed.

All of the methods just mentioned are open to the objection that they use fine gearing at a point where great stress is imposed. Gear-teeth are likely to shear off under such conditions and the small bearings to wear excessively. However, the several mechanical movements are decidedly interesting for their ingenuity. The skate illustrated in Fig. 4 uses a ratchet and pawl at the rear hub but is operated by a long lever reaching to the center of the skate, to which lever the foot-rest is attached. This skate has large wheels and a low center of gravity—both desirable features. A handle just ahead of the foot-rest oper-

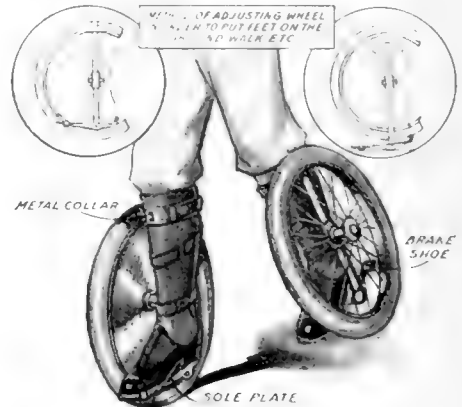

Fig. 5. A single large bicycle-like wheel to be fastened to each of the rider's legs

ates a brake on the front wheel through the medium of a connecting rope.

Other skates are difficult to classify. For instance there is the one shown in Fig. 9, a kind of mechanical centipede. It has nine rollers per skate, arranged in single and double rows, the object of the single rows being to give more of knife-edge

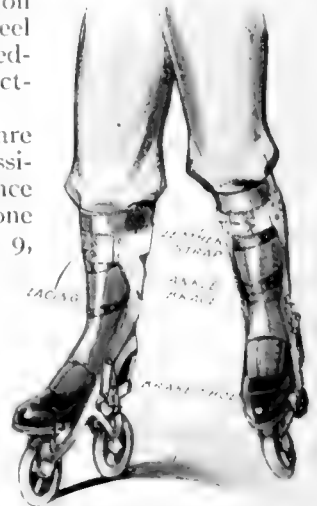

Fig. 6. Skate propelled by taking strokes in the usual simple way

support when desired, as in an ice-skate. This is supposed to be of value in performing fancy evolutions. The axes of the rollers are not all in the same plane but follow a curve, so that by tilting his foot the operator can ride on any pair of rollers he likes. One wonders what would happen if a fat man unexpectedly struck a downhill stretch of slippery sidewalk. Sometimes simplicity, and even hard-running features are Heaven-suggested virtues.

Another skate (Fig. 6) is of the simpler sort. It is propelled by taking strokes,

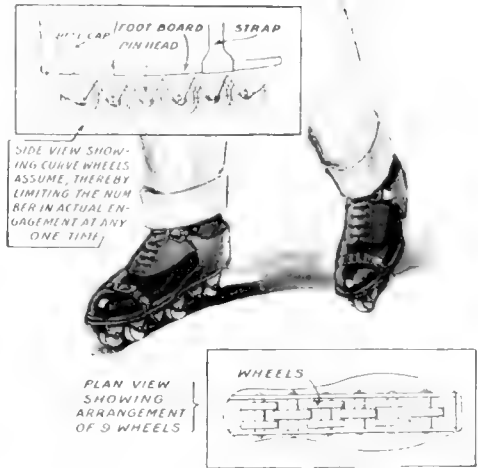

Fig. 9. A mechanical centipede with nine wheels arranged in single and double rows

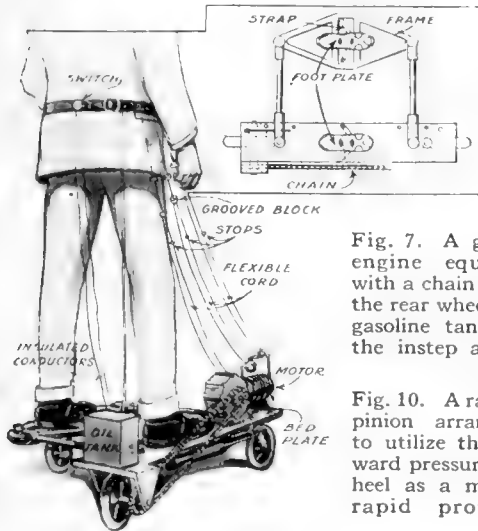

Fig. 7. A gasoline engine skate with a chain drive to the rear wheel and a gasoline tank under the instep and heel

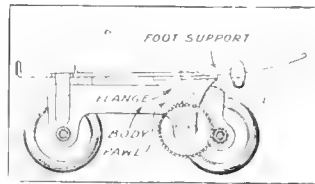

Fig. 10. A rack-and-pinion arrangement to utilize the downward pressure of the heel as a means of rapid propulsion



in the usual way. Skates somewhat similar to this are also made with four wheels each. Fig. 5 shows a type making use of a single, large wheel, fastened to the leg of the rider. By tilting his toe forward the rider can get a hold on the ground and thus bring about "energetic propulsion," to quote the inventor. The large size of the wheel makes it easy to ride over irregularities in the street. But the idea of proceeding down the street with a bicycle-like wheel strapped to each foot does not seem exactly conventional, either.

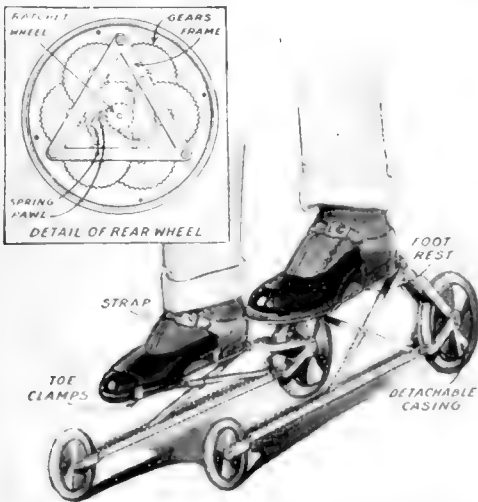

Fig. 8. The descending heel makes a pawl catch in a cogwheel and drives the skate

### A Danger Signal Which Compels Attention

ONCE upon a time it was possible to stand on the corner of a reputed dangerous thoroughfare in a large city or even in the large towns and especially at railroad crossings and experience many of the thrills of melodrama at the narrow escapes of pedestrians and vehicles from accidents. But to-day so many precautions are taken and danger signals are so numerous and so cleverly planned that the number of accidents is minimized.

An electric signal has been designed for a dangerous corner where obstructions, such as trees and buildings close to the sidewalk or fences, shut off the view of approaching streets on a cross street from vehicles on the main street until it is almost too late to prevent a serious accident.

The cross-piece on top of the signal-post is connected by wire with a magnet over which the wheels of the car pass as it nears the corner. This contact of the wheels with the magnet sets the cross-piece in motion, and it continues to oscillate, flashing its brilliant colors insistently, until the car wheels have come in contact with a lever on the other side of the danger zone, the pressure upon which has released the signal wire. This serves as a reminder to the motorman to slow up as he nears the corner and as a warning to pedestrians and drivers of vehicles that a car is approaching.

At night the word DANGER shines out in illuminated red letters, the lights being enclosed in the box on which the lettering appears. A space is also reserved for the name of the crossing streets, making the signal-post a sign-post as well. The colors employed are eye-compelling, and the device has proved to be an efficient guardian of the public safety at that particular corner which has no traffic policeman.



The brilliant colors and the revolving cross-piece cannot fail to attract

### A Safety-Bicycle for the Timid Fat Man

THE fat man who wants to reduce by bicycling but who does not want to fall off and injure himself in the attempt, can now ride with safety on a bicycle fitted with a new rear attachment which will prevent him from losing his balance.

The frame of the bicycle carries an extra pair of small wheels at the back alongside the rear wheel. When these are attached it is no effort to maintain one's balance. Moreover the new attachment makes it easier to mount and dismount.

The wheels are so small that they are scarcely noticeable to the casual observer. Besides the feeling of security which their perfect balance gives, they also share the weight.



How could any one fall off if his wheel is constantly propped up?



# Removing High Lamp Bulbs

HOW are burnt-out bulbs renewed in large electrically-lighted canopies over the entrances of hotels, theaters and public buildings? Ordinarily a long extension ladder is required. A man holds the foot of the ladder to prevent it from slipping; another climbs it to remove the burnt-out bulbs and insert new ones.

A simple device has recently been put on the market which is intended to be used on the end of a long bamboo pole and which enables one man with an ordinary ladder to do this work.

The device consists of three sleeves carrying a set of metal tongues which are bent in the shape of a bulb and covered with rubber protectors for nearly their entire length. The two end-sleeves slide within the middle one. The lower sleeve is fixed on the end of the bamboo pole by means of a spread cotter-pin. The lower ends of the tongues are joined to a disk held in the upper sleeve and joined to the fixed bottom sleeve by means of a coil-spring. To a small eye-lug at the top of the upper sleeve a string is attached which extends down to the hand of the operator.

The man stands on the top of his ladder and lifts the pole up so that the bent tongues slip over the bulb. If the bulb is too large, the man pulls the string, thus moving the top sleeve down so that the tongues can spread out to fit the bulb. By turning the pole around screw-driver fashion, the bulb is taken out of the socket. It is prevented from dropping to the floor by the tendency

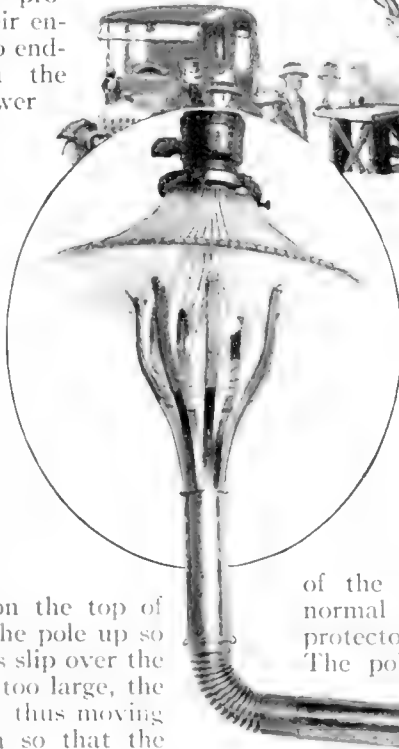
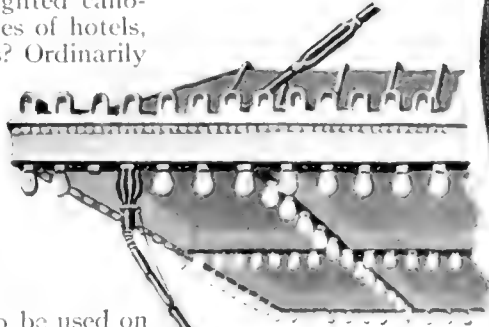

Above, a device for renewing the bulbs in high theater and hotel canopies consists of a long pole at the end of which are rubber-covered fingers to grip the bulb securely

At left, the end of the pole, showing how the rubber-covered fingers grip bulb. The fingers can be spread out or contracted to suit the size of the bulb

of the tongues to return to their normal position and by the rubber protectors, which grip the bulb firmly. The pole is lowered, the old bulb taken out, and the new one inserted.

If the operator does not wish to move his ladder for each bulb to be taken out, he slides the middle sleeve down over the first one. The top sleeve and the tongues can then be bent to either side.



In Victor Hugo's "Les Miserables" Jean Valjean crawled through a sewer. An engineer in Pasadena used a motorcycle

#### A Six-Mile Trip Through a Sewer on a Motorcycle

**N**OT since the fictional days of Jean Valjean has a trip through a sewer occupied so much space in print as the one made recently by the engineer of the newly constructed six and one-half miles of sewer at Pasadena, California. The trip was an inspection tour and was made on a motorcycle. To have walked the full distance would have taken several hours. So the engineer conceived the plan of lowering a motorcycle into the pipe at the clean-out hole in the beginning of the main artery and making a trip de luxe. He had never before ridden a motorcycle. Hence he

chose one equipped with a tandem seat and selected an experienced driver.

A gas headlight on the motorcycle illuminated the passage. The distance was traversed in two hours, in spite of the numerous stops made to investigate walls and manholes. The only unpleasantness experienced was the noise of the motor exhaust, which was almost deafening on account of the narrow confines. Otherwise the plan worked perfectly, the headlight on the motorcycle making the passage as bright almost as daylight.

#### Transforming a Beauty Spot Into a Public Utility

**T**HE water-works of Salt Lake City was recently augmented by the completion of the five-million-gallon Pleasant Valley Reservoir. This was obtained by the simple operation of lining with concrete an old pond. The cost was only \$3,744 per million gallons. That the name—Pleasant Valley—is deserved is apparent from the accompanying view.

Nature is the great resource; she supplies the material. Man is the manufacturer. He transforms a mere scene into a public utility, yet preserves the beauty of the scene. The neglected pond had but one customer—Old Sol—while the concrete-lined city reservoir supplies water to thousands.



By lining a useless old pond with concrete five million gallons were added to the city's storage water supply

Why Isn't This Used Instead of Hooks and Eyes?

AN ingenious German invention for shoe-lacing is intended to take the place of shoe-hooks and shoe-eyes. The ordinary hook is liable to bend out of shape. Often it causes the shoe-lining to bag and press uncomfortably on the foot. Besides, threading the lace through many eyes is tedious.

The new device is a flat clasp on the surface of the shoe or boot. The clasp is made of the best spring steel. When the lacing is passed around it and the clasp snaps down it is hardly seen under the lacing. In an unlaced shoe the clasps spring up and stand away from the shoe, as can be seen on the top left side of the one in the illustration, so that there is no difficulty in bringing the shoe-string around the hook. By drawing the lace tight the hook is pressed down firmly on the surface of the leather. The leather then rises a little and covers the edges of the clasps. The new clasp does not lose its shape.



The clasps spring up and stand away from the sides of the shoe when unlaced

The patient, seated comfortably, places his feet on the slats and envelops his entire body, except his head, in a covering which confines the steam.

A somewhat similar method is employed in the steaming of the different parts of the body. One of the most important uses of the generator is for a steam footbath in case of a sudden rush of blood to the head. The way it is used is plainly indicated in one of the illustrations.

The apparatus also gives excellent service as an inhaler for the throat or to steam the nose or ear. The equipment for such adjustment consists of a short, straight tube and a bulb, as shown

in the upper left corner of the illustration. Three lengths of tubes are used.

Steam Yourself and Drive Away Your Ills

A SMALL steam-generator for family use in case of illness has been invented by a German. His generator can be used to steam either the entire body or a single affected part, whether that part be your left foot or your right ear or any other member.

When a steam bath for the entire body is desired the kettle shown in the accompanying illustration is half filled with water. The shallow pan at the end of the connecting pipe is then set under the wooden slatting seen near it and the whole generator is placed close to a cane chair, when a bathtub is not used, after which the lamp below the kettle is lighted.



The device may be used as an inhaler, or to steam the entire body or any separate organ

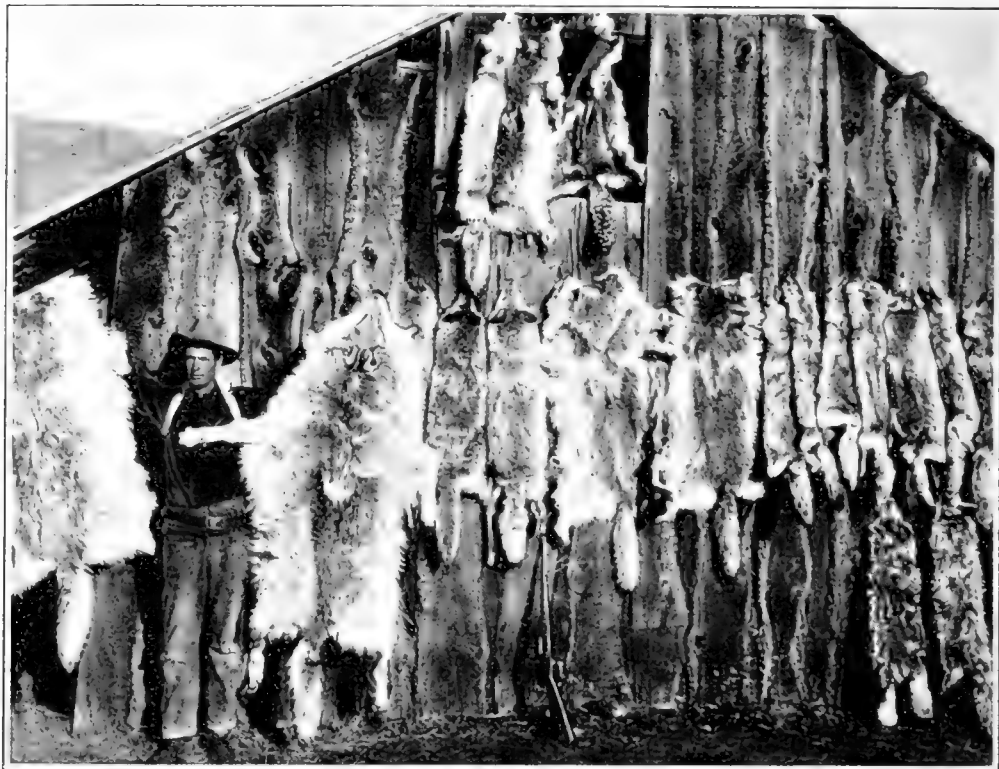

A catch made in the Gallatin National Forest, by an expert hunter of carnivorous animals. Coyotes are the most numerous, but wolves, bears, mountain-lions and wild-cats abound

#### Hunting Destructive Animals in National Forests

UNTIL the work was taken over recently by the Biological Survey under the provisions of an act of Congress, the systematic hunting of carnivorous animals in the national forests of the country was one of the tasks of the Forest Service. Expert hunters and trappers were employed for this purpose, and the accompanying illustration shows a catch made by one man in the Gallatin National Forest. In assigning the work to the Biological Survey, Congress provided an appropriation of \$125,000 for this purpose.

Although private citizens have always been permitted to hunt in the national forests, carnivorous animals have at times abounded in certain of the Western reservations in such great numbers that their depredations proved a serious menace to stock-raisers. The hunters and trappers employed by the Government devote their entire time to shooting

and trapping, and many pelts are obtained by them. Coyotes are the most numerous of the carnivorous animals on the majority of the reservations, and wolves, bears, mountain-lions and wild-cats abound in the order named.

#### How the Firing of Heavy Guns Affects Animals

A GERMAN veterinary surgeon has made some curious and interesting observations upon the psychological effect produced on animals by the firing of big guns. He considered the horses and dogs used for military purposes, and the game in the area of warfare. Soon after the war it was noticed that large numbers of horses and especially dogs migrated into countries beyond the seat of hostilities. The wild boar, the badger, bear, red deer and roebuck followed, but strange to say the hare, whose timidity is proverbial, refused to leave its home. Birds which remained unfrightened were owls, falcons, sparrow-hawks and crows,

# A Machine-Shop in a Diving-Bell

**A** DIVING-BELL in a large steel tank filled with clear water was exhibited in a New York store recently. The tank was fourteen feet in diameter and ten in height.

Suspended from a stanchion overhead was an iron sphere about four feet in diameter. It hung from the stanchion by chains and could be raised or lowered by means of a triple expansion block and tackle. A stout, well insulated electric cable ran into the sphere and disappeared over the rim of the tank to a strange-looking switchboard. Protruding from one side of the ball and equally distant were four powerful electromagnets. The flat surfaces, or "heels" of these were parallel. Facing them was a thick steel plate suspended in the water. From the external switchboard, electric current was sent through the cable and into the electromagnets. They exerted a pulling force of four tons each which drew them and the sphere to which they were rigidly fastened, against the steel plate. The steel plate represented the steel side of a sunken ship. Another switch was thrown on, and a half-inch steel drill which protruded from the sphere between the four magnets commenced to turn until it penetrated the steel plate. Another switch was thrown on. The drill withdrew from the hole it had bored and wormscrews commenced to revolve which shifted the position of the ball slightly, and in a very few minutes another hole was drilled.

Under actual working conditions, this sphere would be used to carry two men to the sea bottom, who would attack the side of a sunken steel or iron ship exactly as the miniature sphere attacked

the steel plate in the diving tank. In the demonstrating apparatus, the stanchion represented the sea barge from which the hollow iron ball carrying the two workmen and their equipment would be lowered to the depths in the vicinity of the sunken ship, through the sides of

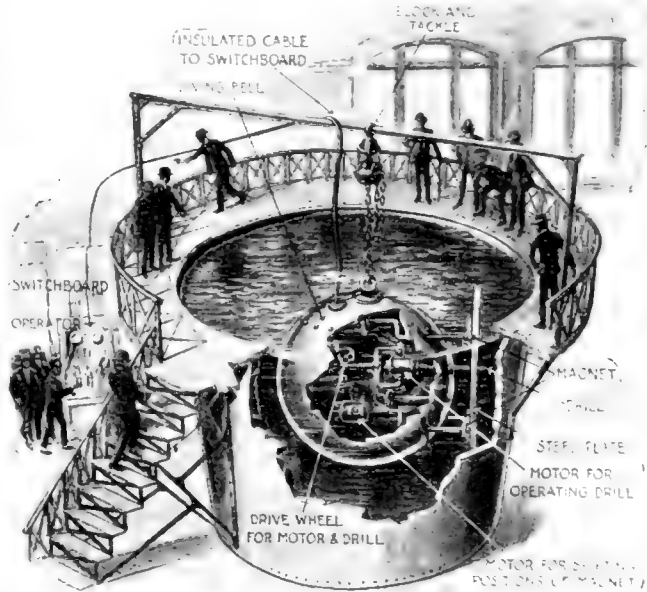

The steel plate in the tank represents the steel side of a sunken ship through which holes will be drilled for grappling hooks

which holes would be drilled as the first step toward raising it to the surface for salvaging.

When sufficient holes were drilled strong hooks would be inserted to which would be attached pontoons. When enough hooks had been inserted and enough pontoons attached to them, the water would be pumped from the pontoons from above. The ship, theoretically, would rise to the surface, and could then be towed without further difficulty to the nearest dock.

While the miniature apparatus performs admirably, the "life-sized" diving sphere has not yet been given a trial.

All the specialized knowledge and information of the editorial staff of the Popular Science Monthly is at your disposal. Write to the editor if you think he can help you.

# A Fleet of Indoor Battleships



One of the ships was mounted on a motor-truck and accompanied by six navy officers it made a two-weeks' tour through New York city recruiting men for the navy

**T**O TRAIN its officers and men in fleet evolutions and to teach recruits the nomenclature of a battleship, eight miniature warships have been so constructed by the Second Battalion of the New York Naval Militia that they can perform on an armory floor all the maneuvers of a battle fleet at sea. With the hulls cut off at the water line and with the ships mounted on wheels located inside where spectators cannot see them, they look like real battleships.

Each ship is operated by men seated within its interior so that their heads come under the forward fire-control masts. From the exterior they are invisible, concealed as they are by the bridge and by weather-cloths through which peep-holes are cut. Two men supply the motor-power. They sit under the superstructure and work hand-levers connected by gears with the forward wheels. From the steering-wheel to an axle aft run tiller ropes. The axle carries a loose wheel on either end and swings freely on a vertical shaft so that when the helm is put over, the stern swings to starboard or to port.

Night practice with the fleet of eight miniature warships is carried on in the armory with all lights extinguished. Equipped with running lights, search-light, trucklights and Ardois signal system, all supplied with current from

storage-batteries, the ships make their way about the armory floor in any formation that may be desired. They make a picturesque spectacle maneuvering in the dark with the aid of their signal lights, the flagship of the little fleet blinking its instructions to those in line behind it, and one after the other repeating the orders.

Large classes of naval men or recruits are often seated in the galleries where they watch the fleet in action and listen attentively to an official explanation of what is taking place. The exact movements of a division of ships are carried out by the same signals as at sea and the ships form column, line, echelon, turn and countermarch with remarkable facility of movement, affording practice which primes the men for the annual summer cruises.

The ships were constructed under the direction of Commander Kingsley L. Martin by the Chief Gunner's Mate of the Battalion, William H. Free, and his assistants at the armory, in Brooklyn. In addition to its value to the Naval Militia, the fleet has interested the general public. At one of the reviews given by the men, at which time the public was invited to a demonstration of the duties and activities carried on by the Naval Militia, about five thousand people saw for the first time how a fleet

of battleships is maneuvered in cruising and battle formations. The visitors were shown how a night blockade is formed. One vessel lighted up a harbor entrance with its searchlight, while the others cruised around on circular blockade with all lights out or very closely screened.

Only recently, as if to demonstrate the versatility of these little ships, one of the eight was placed on a motor-truck and with six navy men from the recruiting office standing at different positions on the deck, the motor-truck made its way through New York city, stopping at corners to give a man an opportunity to address the large crowds which never ceased to gather.

The truck with its cargo and its

### Detecting Enemy Submarines from a Ship's Look-Out

THE present war has demonstrated that effective measures can be taken against a submarine attack by maintaining an efficient look-out. The great difficulty has been that with the best of binoculars and telescopes the movement of the ship constantly disturbs the observation.

To overcome this difficulty, John Gardner, the inventor of the Gardner submarine signaling system, has devised a method by means of which the observer seated with his telescope supported on a stand can be certain that his finding instruments will always be parallel to the surface of the sea, regardless of the rolling and tossing of the ship.

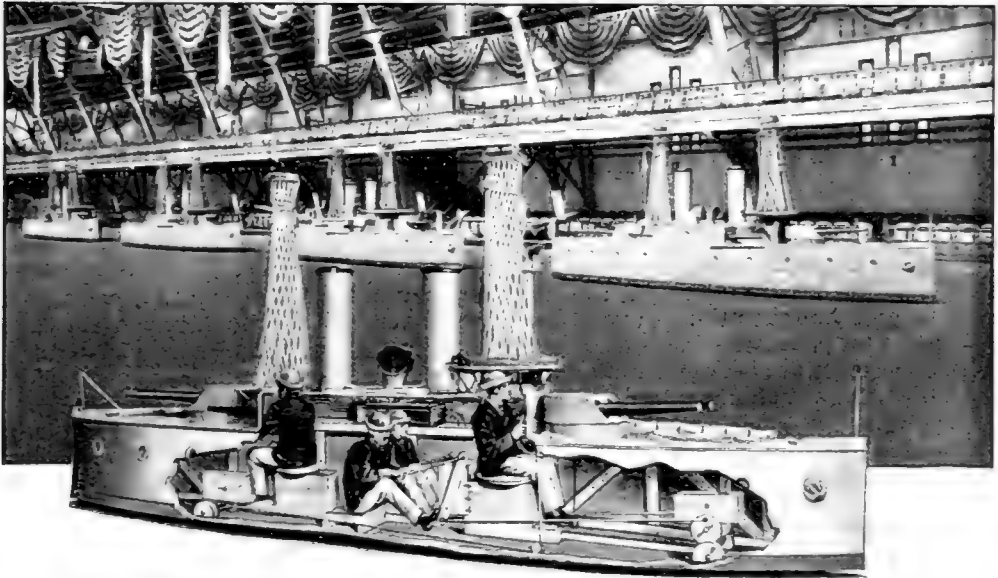

Men concealed within the ship's interior operate hand-levers which move it about on the floor in any formation desired. Each ship is equipped with a complete signaling system and with running lights, searchlight and trucklights for night practice

crew carried on its unique method of recruiting for two weeks. During that time the number of recruits increased noticeably.

The ship mounted on the motor-truck shown in the illustration is a model of the Connecticut. It is twenty-six feet long and five feet wide. The turrets are eight feet above the deck, and were so high that the truck could not get under the elevated road structure without first cropping off nearly a foot of its height.

He achieves this end by mounting a pedestal securely to the deck, and on this a seat with a table to support the telescope on a standard. By the operation of a gyroscope the seat and table are maintained in a position parallel to the sea surface. Furthermore, the platform with seat and table is rotated from left to right by the gyroscope, so that the observer need only concern himself with keeping a sharp look-out over his field.



# Testing an Air-Fighter's Nerve

Is your pulse right? Would you start at the crack of a pistol? How do you breathe? The answer spells your fitness to be an aviator

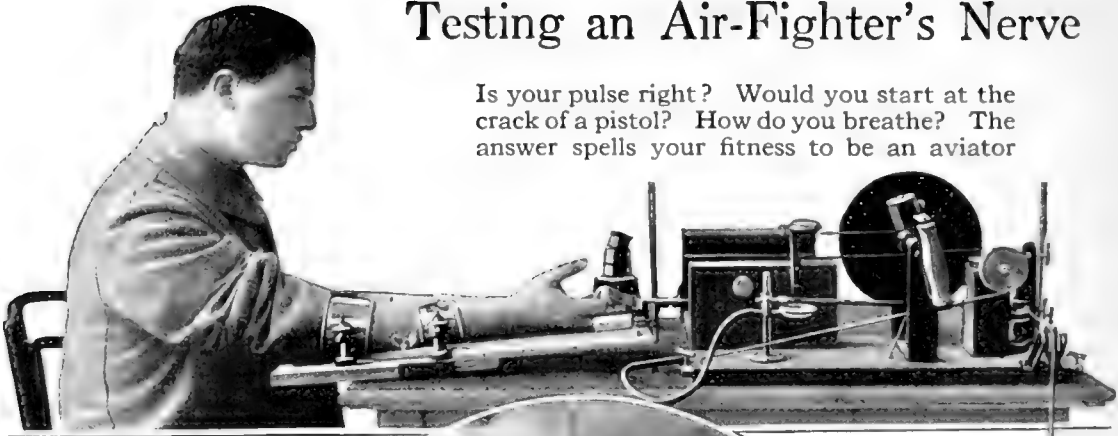

Above, the ergograph, which ascertains the exact amount of fatigue in the arms and fingers after certain exercises

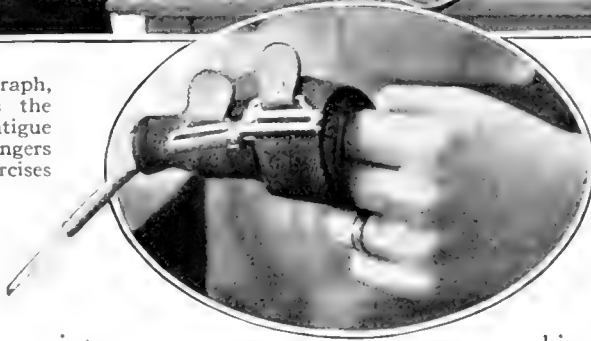

At left, an indicator strapped to the fingers to determine slight variations in the pulse-beats



**T**HE war-aviator must be so constituted that the sudden menace of danger, of shells bursting about him, of machine-gun bullets raining upon him will find him calm and collected. He must face a crisis not only with deliberate calm, but with the ability to escape with a whole skin.

Polo-players, lion-tamers, big-game hunters proved to be the best aviators in the early days of the flying-machine, simply because they were so constituted that they were not appalled by danger. Indeed, they courted perils. Men of this rare type are hard to find. Besides, every man obsessed with the daredevil spirit does not necessarily constitute the ideal aviator. Even timid business men have their moments of reckless daring. What is wanted is the stuff of which Daniel Boones and Shackletons are made.

But in addition to the daredevil spirit, has the prospective aviator muscular and nervous endurance? After clutching for an hour the control-levers of a speedy monoplane, is his hand firm, or does it tremble? After witnessing a terrible accident, is his heart-beat,

his "cardiac rhythm" undisturbed? Is his respiration still normal? Moreover, are his nervous and muscular systems so well balanced and so nicely correlated that his hands promptly obey every external command?

These important questions must be answered in his favor if he hopes to get a job as a war-flier with the French army. The French do not want daredevils to drive their air-machines if they are daredevils and nothing more.

For the purpose of finding out just how favorably every applicant can answer these difficult questions—and he can not answer them with his lips—the French war department employs an ingenious testing machine. Psychologists have known and employed what is called the d'Arsonval chronometer for many years. But it is unlikely that the delicate mechanism has ever been put to such an interesting task.

One part of it tests the pulse-beat. Another determines the tremor of the nerves. Still another registers the respiration. Another apparatus discovers the ability, or the inability, of the applicant to withstand fatigue. After he has

undergone several simple examinations, the candidate is seated in a chair and the final, supreme test is applied.

How would most men act if a revolver were discharged unexpectedly behind their ears? The answer is simple. They would leap into the air; their heart-beat would probably double; they would gasp and tremble as if they had palsy. In so doing they would promptly disqualify themselves as aviators in the French army.

In testing the possibilities of an aviator, various contrivances are attached to the body, all having a definite purpose.

Tubes lead from these devices to a slowly rotating cylinder, on which paper is wrapped. They terminate in points which record the slightest variations in his physique.

When the clockwork has started and he is perhaps wondering what the queer apparatus is all about, a deafening explosion takes place a foot behind him. The record made at that moment on the revolving paper determines whether or not he is to become a French war-aviator. If his heart-beat, his respiration and his arm nerves and muscles show no undue excitement on the paper cylinder, he goes to work. But if the stylus actuated by his pulse-beat dances about the rotating sheet, he is disqualified. It is only natural that his reflex nervous system should respond in some way to this sudden stimulus; but the man who tests him knows how wide a variation from normal may be tolerated.

Next in importance to the revolver-shot test is that which ascertains the candidate's promptness in acting upon an external command. For example, he is told to press an electric button

when he feels a light touch on his left ear-lobe, or when he sees a light flash. His quickness in acting upon these sensations determines whether or not he could meet the sudden contingencies which occur in the air. In a word, whether or not he could handle his 'plane over a roaring battlefield without losing any part of his nerve.



The jagged line on the chart shows the breathing before and after the explosion, indicated by the cross

The d'Arsonval chronometer which records on a smoked paper cylinder the pulse beats, respiration and nervous tremors of the applicant when a pistol is fired behind him

# A Voting Machine for Congress



Above: How the two large registering boards of the mechanical voting system would look if they were installed in the House of Representatives

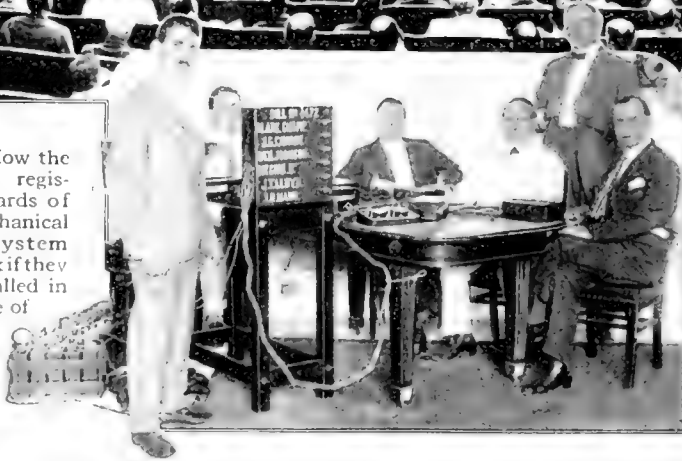

At left: The mechanical voter reduced to a demonstrable size with batteries and connections for a committee examination. It is really a form of telegraph with many key-boards

**F**OR nearly a century, inventors, spurred on by the deplorable roll-call system in use, have devised instruments of one sort or another to enable Congress to register its vote in a few minutes instead of in the forty to forty-five minutes which are consumed by the roll-call. In each case it has been conclusively proven that a mechanical system of voting would not only greatly economize time, but would also effect a large saving in money. And yet, there is no mechanical voting system in use. If there was it would kill filibustering on votes.

During a long session of Congress a mathematician figured that fifty-six days had been consumed in roll-calls alone. A voting machine, which is now being considered, has taken ninety thousand roll-calls. It would give Congress two

hundred years' work to call the roll that many times. The inventor, Bornett L. Bobroff, of Milwaukee, Wisconsin, has installed his system in the State Legislature of Wisconsin, and it is giving excellent service there. In a single session of Congress he says he can lop off thirty days' work by calling the roll with his machine.

Each member votes by pressing a button on the desk in front of him. He and everybody else can see how he voted, as his vote duplicates itself on a large board within the view of all. The board also totals the vote automatically. In the event that a member wishes to change his vote he merely presses another button provided for that purpose and the total of "yeas" and "nays" is accordingly corrected on the board.



The bridge will be erected over the shortest distance between the central shores of San Francisco and Oakland, the bay there being very shallow and beyond the busy shipping district

### A Bridge Five and One Half Miles Long

**S**AN FRANCISCO is planning to build the greatest bridge in the world. It is to connect Oakland and its contiguous districts with San Francisco, and is to relieve five ferry systems of passenger and vehicular traffic.

The proposed bridge will cost twenty-two million dollars and will be five and one half miles long. It will be one of the heaviest bridges ever built, carrying three roadways and four railroad tracks. Its main portion is to be made up of sixteen spans each two hundred and fifty feet long.

Near the San Francisco shore there will be two long and high spans under which the ships will pass.

The bridge will be a double-deck structure. Three roadways will extend along the upper deck and four railroad tracks along the lower deck. Its capacity has been made great enough to provide for traffic for many years. It will have two tracks for overland passenger trains, two tracks for electric trains, and three separate roadways.

### Fanning Yourself with the Rocking-Chair

**E**VERY time you sit in the family rocker and move yourself backward and forward you are unconsciously wasting energy. Why not use the energy? Dozens of inventors have asked themselves that question. Charles H. Towers, of Philadelphia, has answered it by making the rocker drive a fan at the rate of four hundred and fifty revolutions a minute.

The accompanying illustration shows a young lady fanning herself by rocking the chair in which she sits. The fan, mounted on a pedestal at the right

elevation for a good breeze, is connected by a flexible shaft with a gear-wheel, which, together with an operating lever resting on the floor, can be attached to any chair-rocker.

The operating mechanism consists of a casing with a gear-wheel affixed to an arm which travels over the floor on a small roller. As the chair rocks the arm tilts up and down, thus rotating the gear-wheel. The gear-wheel meshes with a small pinion attached to a shaft.



A gear-wheel with a small pinion attached to a flexible shaft imparts the motive power of the chair to the fan

# Flood-Lighting Niagara Falls

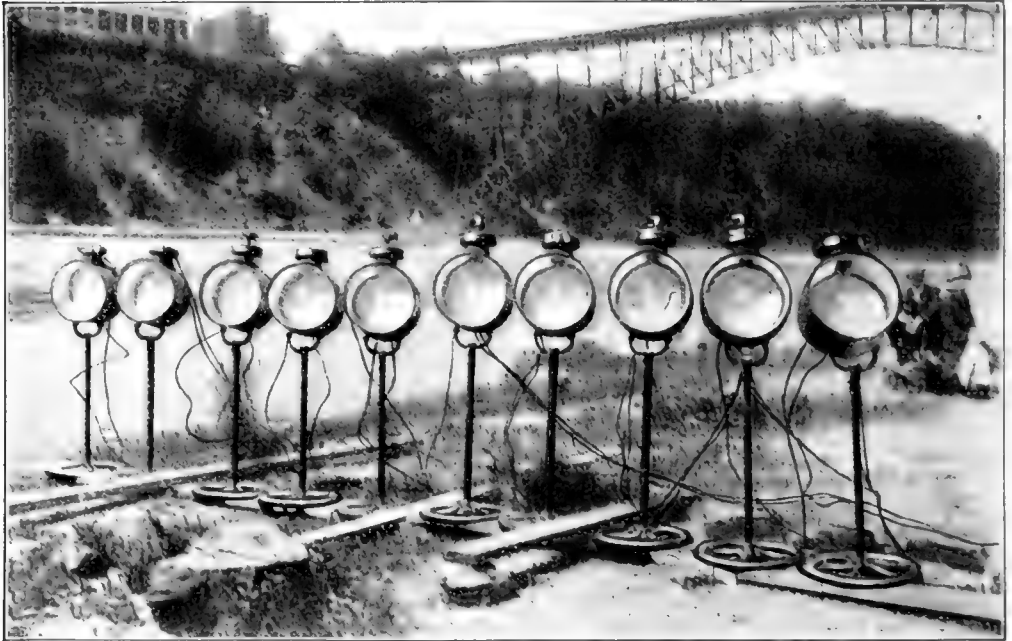

A battery of incandescent lamps which play upon Niagara's waters. With these lamps Niagara is to be brought out of the night and bathed in electric radiance

**I**LLUMINATING Niagara Falls at night by artificial sunlight is the ambitious scheme now occupying the attention of prominent engineers and the officials of Niagara Falls, New York, who have authorized an expenditure of ten thousand dollars for the project.

For several nights a battery of twenty-five flood-lights was turned on the American Falls and the rapids of the Niagara River, to the great delight of thousands. Indeed, the effect was so successful as to exceed the expectations of the promoters. It is now planned to double the number of lamps in service and from time to time to enlarge the battery as new lighting effects are desired.

In illuminating the waterfall at night the light is projected from an ingenious patented reflector, which spreads beams of pure, yellow light which very closely resembles sunlight upon the curtain of falling water and mist. An artistic realistic effect is produced, which would be unattainable by any other means. With this system of flood-lighting,

receiving its power from the Falls themselves, there is no dark center or wing-shadow in the light beam. The Falls are smoothly and softly lighted. On the other hand, the beam is powerful enough to penetrate the densest parts of the rolling mist.

Strange as it may seem, the Falls are thus illuminated not by electric arcs, but by incandescent lamps. This achievement was made possible by the gas-filled lamp, remarkable for its renewing properties. It is a one thousand-watt one hundred and ten-volt tungsten lamp, which is filled with an inert gas, such as nitrogen or argon. Such lamps are now competing successfully with arcs in street-lighting. The reflectors used at the Falls are as true parabolas as it is possible to make them commercially, and they give a powerfully concentrated beam of light rated at one hundred and fifty thousand candlepower in the center of the beam, when used as a flood-lamp, and as high as five hundred thousand candlepower when they are employed as a searchlight.

## Artificial Sunlight to See Niagara by Night



Niagara as a night attraction. When the installation is completed the Falls will be illuminated by artificial sunlight from one hundred and thirty incandescent lamps arranged with such skill that their soft rays will not reveal their hidden source.

### Testing the Lifting Capacity of Balloon Fabric

THE accompanying photograph gives an accurate idea of the great strength of balloon fabric. Six men are shown in a basket suspended from a balloon patch. In the ordinary balloon there are twenty such patches, which means that the huge gas-bag is strong enough, considering only its fabric, to bear the combined weight of one hundred and twenty men.

The photograph is interesting from another angle. It shows how the ropes are attached to the fabric. The ends of the ropes are first separated into four strands which are frayed out and sewed to the fabric after which another layer of fabric is cemented over it. The basket is designed to accommodate two persons, yet the combined balloon patches have a lifting capacity of more than ten tons.



There are twenty patches in each balloon

### The Night Eyes of the Coast Artillery

IN ORDER that the coast of the United States may be guarded by night as well as by day, the officers of the Coast Artillery have developed a type of searchlight larger than any hitherto used in the United States Army. The one illustrated is located at Fort Terry on Plum Island, where the United States maintained a military camp for boys this summer.

Guarding the entrance of the sound there are fifteen such searchlights. Under favorable conditions the beam from one of these giant searchers can "pick up" ships at a range of ten thousand yards, or almost six miles. Under

ordinary conditions its range is about seven thousand yards. The light itself consists of the barrel, which is a large horizontal cylinder, in the back of which is a great parabolic mirror which measures sixty inches across. The front of the barrel is closed by plate glass. Between the glass and the mirror an arc plays between two horizontal carbons, capable of developing eighty thousand candlepower. The carbons are fed automatically and last for about five hours when the light is in steady use.

Each searchlight, a unit in itself, is mounted on a truck, by means of which the light may be moved to various points. A motor operating the moving mechanism of the light is connected electrically with the controller which may be at any distance from the light.

By means of this arrangement an officer in an observation tower may manipulate the light in any direction desired by using a series of levers.



Under favorable conditions the beam from this giant searchlight can "pick up" ships almost six miles distant



**A Peaceful-Looking Hat Which Makes You a Walking Arsenal**

"HANDS UP!" is not such a disconcerting command after all, provided one wears the hat shown in the accompanying illustration. When the highwayman gives directions as to how he would like to have you hand over your valuables, you look him calmly in the eyes and then shoot him by simply blowing a tube passing from the mouth to the trigger of the gun mounted in the top of the hat.

Several cartridges are provided in the magazine, so your aim need not be perfect. Furthermore, the recoil from the explosions will not unsettle the hat. It cocks the hammer for the next shot and ejects the used shell. The cartridges are automatically fed to the breech of the gun

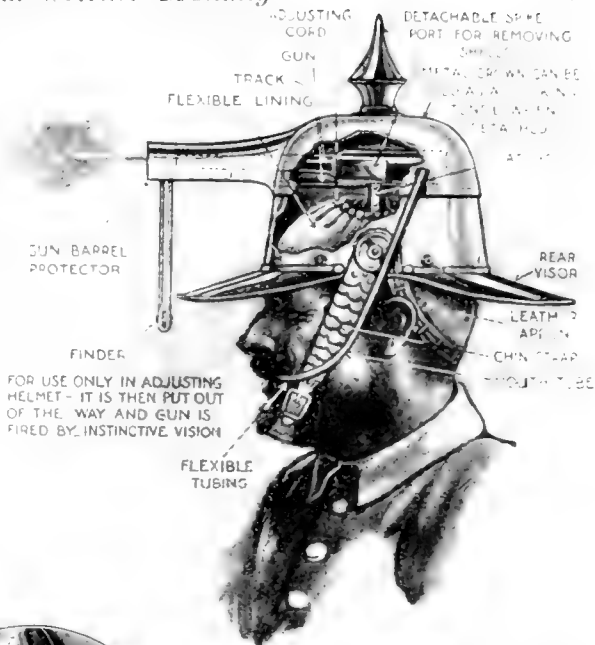

The gun is aimed by turning the head and fired by blowing through the tube in the mouth



The suit is provided with numerous tubes through which air passes to the wearer

and when the magazine is empty the trigger can not be operated. A new magazine is then substituted by removing the hat. The gun is aimed with the turning of the head and by blowing through the tube a bulb is expanded which trips the cocked hammer, exploding the cartridge. When detached from the base of the helmet the crowned section may be inverted and used as a cooking utensil, the elongated hood serving as the handle.

**Mechanical Lungs for the Protection of the Fire-Fighter**

A SMOKE-MASK suit has been devised which operates on the principle of the human lungs. Two tubes supply the wearer with oxygen from a tank carried in a pocket attached to the suit, one for the mouth and the other for the nose. The suit is provided with numerous air-circulating tubes connected with the nose. The mouth exhalations are carried to the tank and come in contact with the purifying oxygen before the air is again breathed.

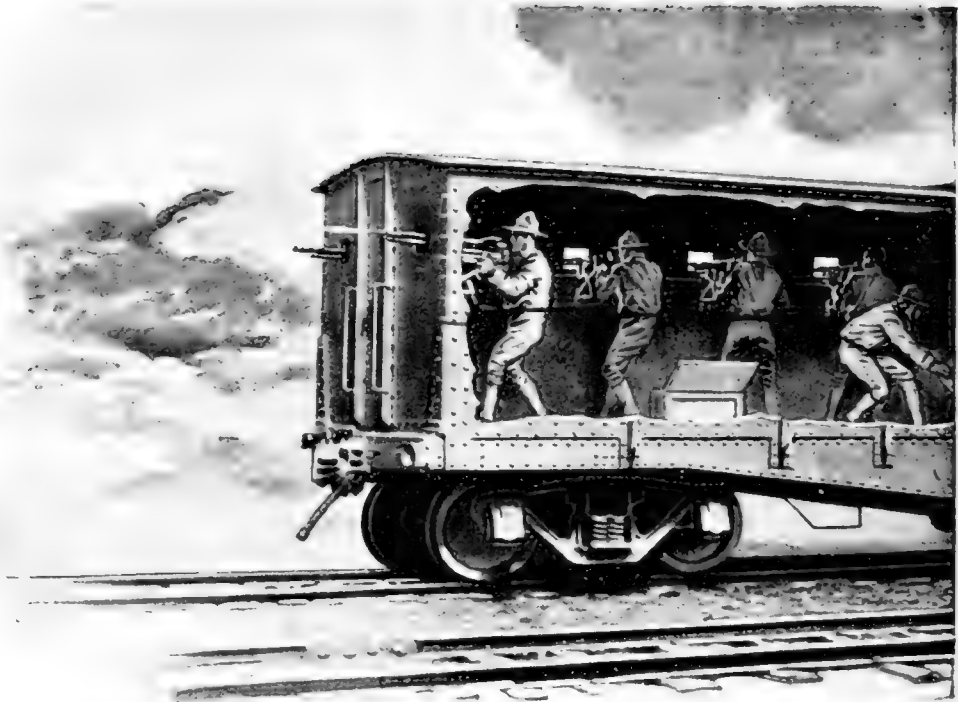

The United States Army's first armored car has twenty port-holes for machine-guns and a well in the center for a three-inch rapid-fire field piece

## Our First Armored Car

THE first armored car to be constructed under the direction of the Board of Engineers of the United States Army has been inspected at the Sandy Hook proving grounds. The car was designed and built within twenty-seven days. It will no doubt be sent to the Mexican border, to be used in actual operation.

The service for which the car is intended is primarily to guard railroads and depots adjacent to railroads. It is not ordinarily to be employed in aggressive movements. In effect, it is a movable blockhouse which may be used at any point along the line. It may serve as a retreat for troops past danger points, or for the transportation of explosives or material of a perishable nature which might be damaged by fire from the ends.

The car consists of a heavy steel-plate structure erected upon a standard flat-

car frame. The plate is of sufficient thickness to withstand fire from small arms. The interior is divided into three compartments. Through port-holes in the end compartments, machine-guns and rifles may be fired by soldiers within the car. The center compartment, which is lower than the full height of the car, is used for the storage of ammunition. Enough ammunition may be stored to supply the small arms and the three-inch rapid-fire field gun mounted on top of the car. This gun has a special recoil mounting. It takes a crew of three trained men to operate it. The gun-well may also be used as a fighting-top for troops armed with machine-guns or rifles.

The car will accommodate a platoon of infantry seated on camp stools or on benches. When used for patrol purposes there would not be more than twelve men in the car, to operate the rapid-fire

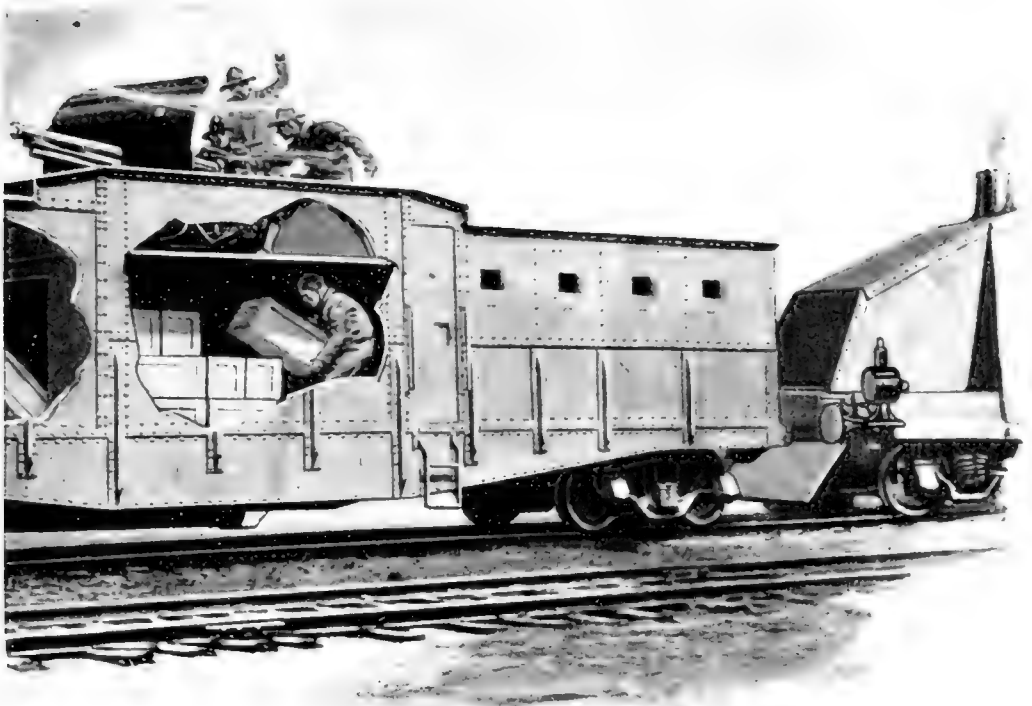

gun and machine-guns. A dry-hopper lavatory and a water tank having a capacity of three hundred gallons, from which the water is brought to the interior of the car by a hand-pump, has been installed for the convenience of the soldiers. The car weighs approximately ninety-seven thousand pounds, which is less than the weight of the armored railroad cars now in use abroad.

There are twenty port-holes for machine-guns or small arms, eight being located on each side of the car and two in each end. These openings are covered with sliding doors of heavy steel when they are not in use. In addition there are also six peep-holes, two in each side of the car, and one in each end. Access to the car is obtained through four door openings, one on each side and one on each end. A ladder in the middle compartment enables the gunners to

reach the gun-well at the top of the car.

The armored railroad car first came into use in South Africa. There it met with conspicuous success, opening the eyes of European nations to its serviceability in war. During the recent periods of internal strife in Mexico Villa's troops converted a freight car into a movable fort on wheels. It took part in a number of pitched battles and did excellent service in guarding the railroad's right-of-way and in transporting ammunition stores. Port-holes were cut in the sides and ends of the car and through these rifles and machine-guns were fired. The active part played by this car in a desultory war convinced our army officials of its military value. On the other hand, armored railroad cars were long ago introduced in Europe as the direct result of the splendid showing made by the first car in South Africa.

---

Maybe you have special needs. Write to the editor about anything within the scope of the magazine. He will be glad to help you.

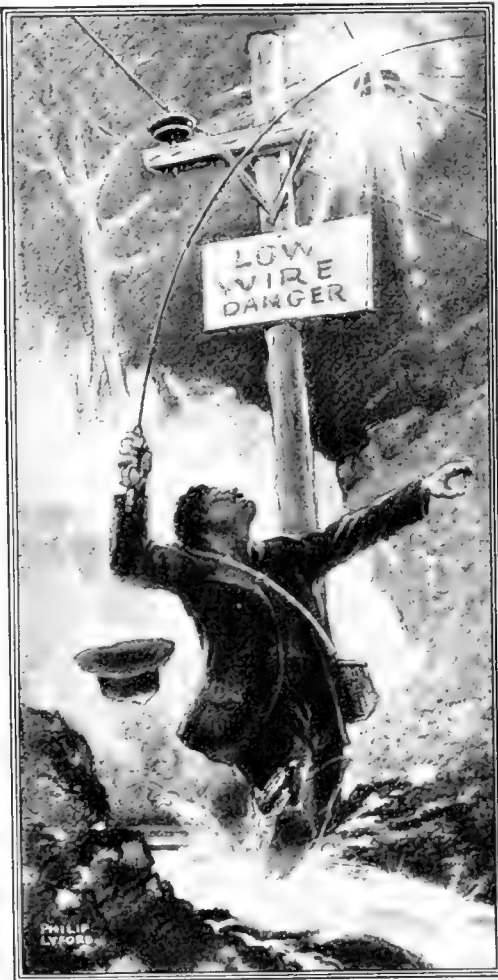

In making a long cast the steel fishing rod was thrown against high-tension wires and the fisherman was killed almost on the instant

#### A Warning to Fishermen

WHILE fishing in a small Pennsylvania stream the Rev. W. P. Perry was killed almost instantly when the steel rod he was holding became entangled in high-tension transmission wires over his head. He was wading in the stream at the time and whipping the water in the

usual way. With no thought of the live wires he made a cast with the line and there was a blinding flash. The current of twenty thousand volts leaped down the rod, coursed through his body, and killed him before he could make an outcry.

This is said to be the first instance on record of the death of a man under such circumstances. During severe winter storms it is not infrequent to hear of electrocutions, due to fallen live wires hidden in debris.

#### Expending Four Tons of Energy in Playing the 'Cello

A SIMPLE air played on the violoncello calls for a total expenditure of energy equal to two and three quarter pounds per note or more than four tons of energy for the single selection. This statement is vouched for by Professor Poffenberger, of Columbia University, who made some experiments in his laboratory with the aid of the famous Dutch 'cellist Michael Penha—experiments made to determine the amount of sheer physical strength required to play the violoncello in the style of a great artist.

A special apparatus is necessary to conduct the tests. Against the surface of a revolving carbon cylinder is suspended a chalked point which is actuated by a slender wire attached to the musician's finger. At each pressure the tension vibrates along the communicating connection and records the energy expended.



When Michael Penha played a simple Bach aria this instrument registered an expenditure of more than four tons of energy

At a recent test Michael Penha at times raised the point to a distance equaling three pounds in weight, that being the record of the forefinger. The pressure alone required to produce the characteristically luscious tones of a simple Bach aria averaged two and three quarters pounds per note. The total energy expended amounted to nine thousand four hundred and fourteen pounds, or more than four tons.

This same amount of energy would be sufficient to carry a laborer through his entire day's work. Yet it took but five minutes for the artist to exert the same amount of force.

**Old Dobbin Carries His Umbrella With Him**

A CINCINNATI teamster who wants to make life more endurable for his horse during the torrid summer days when it is out in the broiling sun earning a living for him, has devised a horse umbrella which consists of a canopy of canvas stretched over a steel frame which clamps to the shafts of the wagon. The horse is thus effectively protected from the rays of the sun and wherever he goes he carries the umbrella.

When hitching or unhitching the animal it is not necessary to detach the canopy. The horse backs right under it between the shafts as if it were not there. The umbrella not only serves its purpose as a protection against the sun, but it shelters the animal from rain.

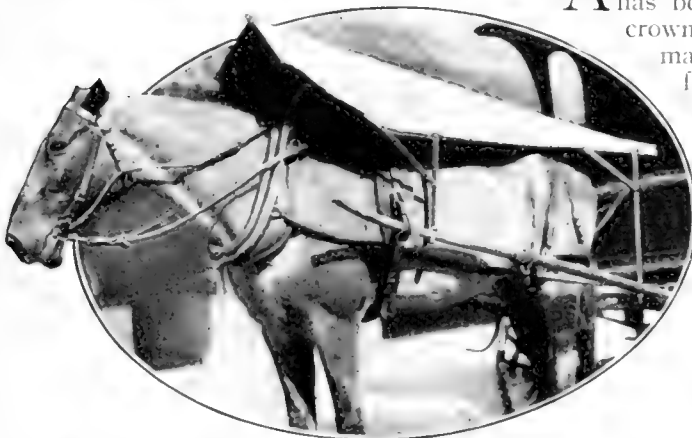

A canopy of canvas is stretched over a steel frame which is clamped to shafts of the wagon but does not touch the horse



The dust collects in a drawer in the bottom of the hopper and the corks emerge cleaned

**Cleaning Crown Bottle-Corks in a Portable Hopper**

A PORTABLE automatic screener has been invented for cleaning crown bottle-corks and any material of granular or lump form, such as coffee-grain or the like. The illustration shows crown corks being dumped into the device. The corks emerge at the bottom, cleaned of any particles of cork or splinters.

The hopper has a series of zig-zag sloping screens in the interior. The corks roll from these zig-zag screens to a rotating wheel with radial screen vanes, which agitates them.

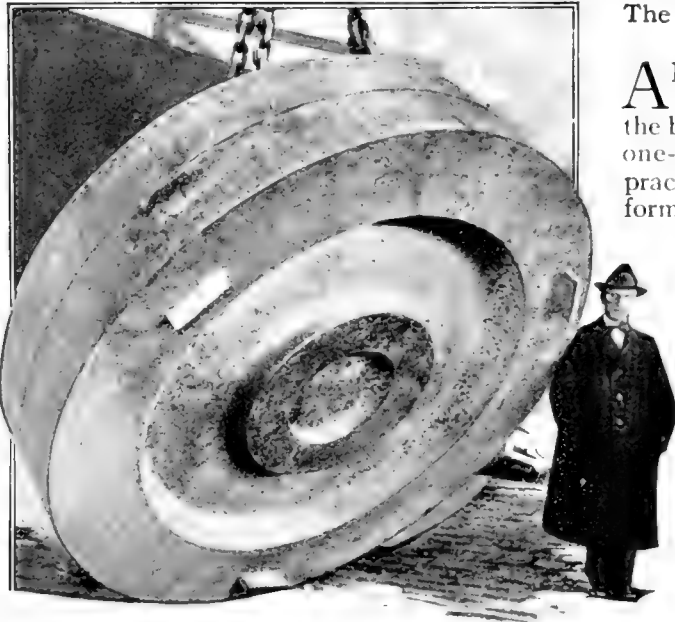

When this fifty-six-thousand-pound flywheel is spinning in the hold of a ship seasickness is prevented

#### Preventing Ships from Rolling by the Use of Giant Flywheels

**T**O travel over the roughest seas or through the most varying winds with no rolling or rocking of the craft is believed to be a coming possibility—if it has not already been achieved. The new principle has been applied to some of the smallest yachts and to aeroplanes and is now being extended to larger vessels.

The accompanying illustration shows the largest steel casting ever made for this new purpose. It weighs 56,000 pounds and is 10 feet in diameter and 27 inches thick on its face. Two of these are now being installed on a United States army transport. They constitute the principal part of what is termed a gyroscopic stabilizer.

The mechanism depends for its success on the fact that when revolving at a high rate of speed, the usual motion imparted to a vessel by the waves is offset by this revolving mass. This particular casting revolves 1150 times per minute.

#### The Sidewalk Coaster Becomes an Automobile

**A** MECHANICAL cross-breed between the motorcycle and the boy's sidewalk coaster, is the one-passenger motor vehicle practically a motor-driven platform, illustrated below. Its pressed steel platform suspended four inches from the ground between wheels is fitted with pneumatic tires. The motor is attached to the front wheel and provides ample power to meet all road conditions.

The fact that you stand in driving the vehicle and the further fact that your weight is carried between the wheel centers, makes it very easy to balance the machine. There is practically nothing to watch but the handlebar which supports the rider and steers and controls the operation and speed of the machine. Both brake and clutch are operated by moving the handlebar forward or backward.

The machine is intended primarily for short distances but enough gasoline can be carried in the tank for a trip of one hundred miles. The speed can be increased to twenty-five miles an hour.



The handlebar controls the speed of the machine, steers it and operates the brake and the clutch



# For Practical Workers

## How to Make an Alcohol Lamp and Blow-Torch from an Oil-Can

THE spout of the can is cut off so that about  $2\frac{1}{2}$  in. remain above the thread. This portion of the tube is then filled with a wick the same as for the ordinary torch. A piece of brass tubing, bent as shown and soldered to one side of the spout, provides a means of attaching a small rubber tube for a blow-pipe. Wood or denatured alcohol is used for the fuel. A torch made up in this manner can be used for soldering in very difficult places as the flame may be easily directed into places that cannot be reached with a soldering iron or with the flame from the ordinary kind of alcohol lamp.—LAWRENCE V. GREENHAUS.

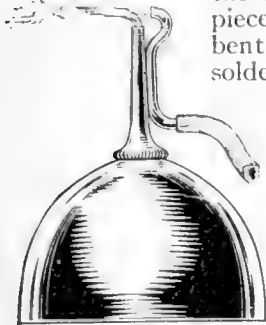

The piece of brass tubing carries a rubber blow-pipe

Two Good Calking Compounds for Boats

## Two Good Calking Compounds for Boats

THE best calking compound used is made of equal parts, by measure, of white lead ground in linseed oil and paraffin. Put the white lead in an iron pot and heat it, then stir in the paraffin. While still hot apply to the seams with a seam brush. This mixture will make any boat water-tight and will not contract and fall out of the seams as some compounds do.

Another good compound is one part Portland cement to six parts coal-tar. Boil and brush over the entire boat bottom while hot. This mixture is generally used as an extra heavy calking for old boats.—J. J. STURMER.

## Making Automobile Wheels Track Correctly

MOTORISTS are often puzzled because one tire will wear out faster than the others and give considerably less than the required mileage. Generally the trouble is always experienced with the same wheel and the tread appears to have been ground away by a coarse emery wheel. If this condition exists, it is time to check the alinement of the wheels to make sure they track correctly. The recently invented device illustrated makes it possible to do this in an accurate manner.

It consists of a base-piece of pipe resting on cast-iron feet or pads and having sliding heads in the pillars at

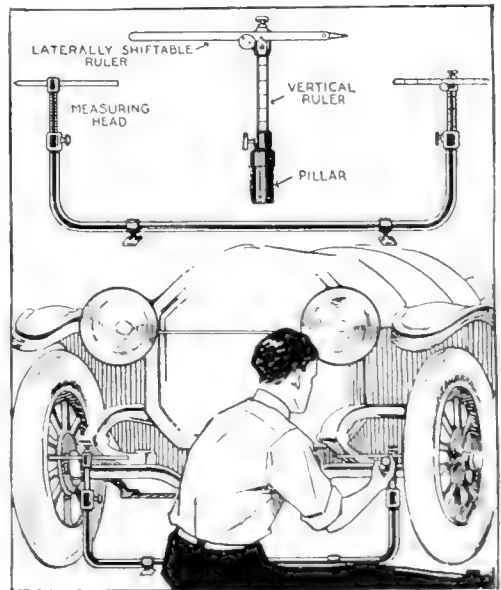

The base-piece rests on cast-iron pillars with sliding heads which are graduated rulers

each end. These are graduated, one of the rulers having a vertical movement whereas the horizontal one can be moved laterally and both can be set when the measurements have been as-



certained. The front wheels are the worst offenders and if the wheels "toe-in" or out unduly, rapid tire depreciation is unavoidable because the wheels do not roll freely and the tires have a combined rolling and sliding action which is very destructive to the treads. The method of using this fixture is also clearly outlined.

#### Accelerating the Cooling Water Circulation

THE engines of many popular light automobiles are cooled by the natural or thermo-syphon system of water circulation, which depends upon the displacement of hot water in the water-jacket by heavier, cooler water from the radiator. This method of circulation gives good results, but some favor the more positive and faster movement of the cooling liquid such as is produced by the use of a pump.

Unfortunately, it is not always possible to instal a pump in a system designed for natural circulation. The flow of water may be accelerated by the simple device shown in the illustration. One of the water-pipes is fitted with a

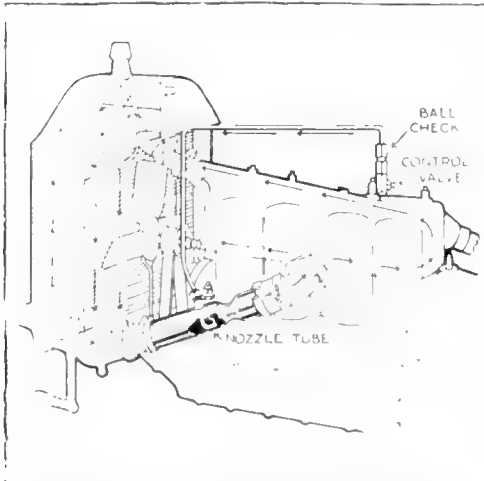

An arrangement for quickening the cool water circulation by an injector action

tube so that the enclosed end points up and on the outside carries a nozzle connected to the exhaust manifold by a tube attached to a ball-check fitting. At every explosion an easily variable quantity of gas is by-passed to the

nozzle and circulation is quickened by an injector action. The check-valve is necessary to prevent water being drawn back into the engine should it backfire. Arrows show the direction of gas and water.—V. W. PAGE.

#### A Pencil Sharpener with an Adjustable Blade

MANY persons find it a serious objection to pencil sharpeners that it is impossible to get a sufficient length of point on a pencil, the sharpeners ordinarily cutting the lead at the same taper as the wood, bringing it to a point only a short distance beyond.

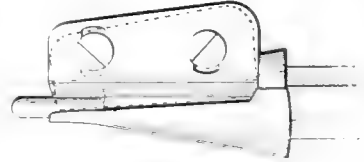

By loosening the outer set-screw the blade is adjusted

A pencil point of any length may be obtained by the use of one of the familiar forms of sharpeners such as illustrated, in which the blade is adjustable by means of set-screws at each end, the cutting edge of the blade extending across the axis of the pencil.

By loosening the outermost set-screw and moving that end of the blade outwardly to a slight extent, as indicated by the dotted line, the lead is allowed to pass the blade without being cut, and the thickness of the point portion may be determined by the distance the blade is swung.—CHRISTIAN NIELSON, JR.

#### A Quick Method of Repairing a Broken or Cracked Die

PART of a broken tooth on a male gear-die which was wanted in a hurry had to be renewed. The broken tooth was dovetailed (after annealing) and a piece of cast steel fitted in and roughly finished. It was then carefully brazed and annealed while cooling. After cooling, the brazed tooth was finished with a file and the whole die tempered as usual, care being taken not to heat enough to melt the brazing.

The job stood well, thousands of brass gears 1 16 in. thick having been punched with the repaired die.

# Equipment for the Home Worker

J. H. Constantine

Instructor in Industrial Arts, Teachers'  
College, Columbia University



ANY man with a few well selected tools and an ordinary amount of skill can eliminate the expense and trouble of calling in a mechanic every time there is some little house repairing to be done. In selecting an equipment it is not a good plan to buy one of the sets made up in cabinets, as there are generally tools in these that are unnecessary and in some instances of an inferior quality. A better plan to follow is to consider the character of the work likely to be done, then select the necessary equipment to do it, purchasing only high-grade tools, as these will do the best work, last longest, and therefore are cheapest in the end. Any dealer who makes a specialty of supplying tools for schools or amateurs can give valuable advice on this subject. The following tools generally meet all the requirements of the beginner and additional ones can be obtained as the need for them arises.

## The Bench

A strong bench is a necessity if accurate work is to be done, the essential features of which are:

I. Rigidity: This may be secured in a bench made with mortise and tenon joints, or of draw-bolt construction, Fig. 1. The bench should be firmly fastened to the floor by lag-screws passing through the two foot-pieces.

II. An ash or maple top with a trough at the back.

III. A drawer or rack where the tools can be kept when not in use. The former is more satisfactory.

IV. A side vise: The strongest, most durable and convenient is the rapid acting vise, with all working parts of metal. This vise requires oiling occasionally. Facing the jaws with maple prevents injuring finished work.

V. A tail vise: This vise, also of metal with a long screw not rapid acting, is very convenient for certain kinds of work.

The bench may be made at home, or bought for from \$9.50 to \$24, depending on the style and size.

The following list of tools may seem large to the average man, but the writer has found from experience that occasions are sure to arise when each tool will be needed in general house repairs.

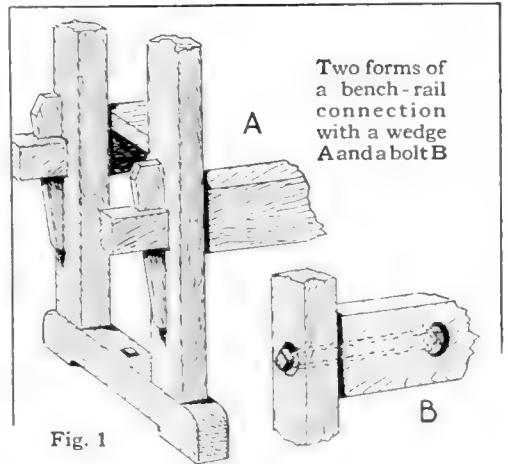

Fig. 1

Two forms of a bench-rail connection with a wedge A and a bolt B

- 1 Stanley jack plane No. 605.
- 1 Stanley block plane No. 65½.
- 1 Iron spokeshave No. 54.
- 1 Disston cross-cut saw 22 ins. 10 points.
- 1 Disston rip-saw 22 ins. 8 points.
- 1 Disston back-saw 10 ins. No. 4.
- 1 Buck Bros. socket chisel 1¼ in. handled and sharpened.
- 1 Buck Bros. socket chisel ¾ in. handled and sharpened.
- 1 Buck Bros. firmer chisel ¾ in. handled and sharpened.

- 1 Buck Bros. firmer chisel  $\frac{1}{4}$  in. handled and sharpened.
- 1 Hammond adz-eye claw hammer, 9 oz.
- 1 Disston hardened blade try-square 6 ins.
- 1 beech marking gage.
- 1 Buck Bros. outside bevel gouge 1 in. handled and sharpened.
- 1 Buck Bros. inside bevel gouge  $\frac{1}{2}$  in. handled and sharpened.
- 1 box-wood rule, No. 2, 4 fold.
- 1 Disston sliding T-bevel No. 3, 6 ins.
- 1 pair Starrett spring dividers 8 ins.
- 1 bit file.
- 1 slim taper saw file 6 ins.
- 1 rat-tailed wood file 8 ins. handled.
- 1 key-hole saw.
- 1 Barbers ratchet brace No. 33, 8 ins. sweep.
- 1 mitre-box.
- 2 Jorgenson hand-screws 10 ins.
- 1 monkey-wrench 6 ins.
- 1 screw-driver 8 ins.
- 1 screw-driver 4 ins.
- 1 pair pipe-pliers.
- 1 pair side-cutting pliers.
- 1 hack-saw frame.
- 6 hack-saw blades.
- 1 Stilson wrench 10 ins.
- 1 glass cutter.
- 1 nail-pull (nippers).
- 1 Carborundum oil-stone, medium and coarse combined, in iron box.
- 1 set Russel Jennings auger-bits 4 16 in., 5 16 in., 6 16 in., 7 16 in., 8 16 in.
- 1 nail-set 1 16 in.
- 1 set twist-bits 3 32 in., 4 32 in., 5 32 in., 6 32 in., 7 32 in.
- 1 Clarke's expansive bit  $\frac{1}{2}$  in. to 1 1/2 ins.
- 1 Taintor saw-set.

The cost of the equipment listed, without the bench, will be about \$24.

Supplementary list of tools useful but not indispensable:

- 1 Langdon iron mitre-box with back-saw.
- 1 Parker iron vise.
- 1 pair Compton's metal snips No. 12, 2 ins.
- 1 foot-power grind-stone or No. 10 Carborundum tool-grinder.
- 1 saw-filing vise.

The cost of this supplementary equipment is about \$20.

### Care of Tools

One of the most common faults of the beginner is to work with tools after they are dull. All edged tools should be sharpened often and carefully, in order to keep them in perfect condition.

### Chisels and Plane-Irons

These tools come ground to 20 or 23 degrees as indicated in Fig. 2. They should be whetted on the medium side of the oil-stone to an angle of 25 degrees. Use plenty of kerosene oil to prevent burning the tool or glazing the cutting surface of the stone. Rub over the entire surface so the stone will wear evenly. The whetting will raise a thin wire edge on the tool which can be partially removed by turning the chisel or plane-iron over on the flat side and rubbing it gently back and forth on the stone. It is very essential, however, that the tool be kept perfectly flat during this operation, as any bevel on the flat side impairs its efficiency. If any roughness remains on the cutting edge it may be removed by stropping on a piece of

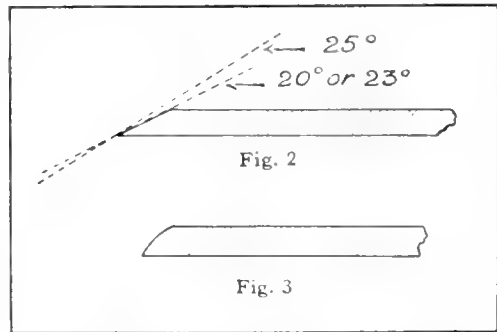

The bevel of a chisel as it is when new and after it has been used for some time

leather. After these tools have been whetted often the bevels will assume the shape shown in Fig. 3. In this case they must be ground to restore the original angle of 20 degrees. The grinding may be done on a grind-stone or emery-wheel. If neither of these is available the coarse side of the oil-stone will answer the purpose. The cutter for the spoke-shave may be sharpened in the same way. The gouges must be sharpened on a slip-stone, that is, an oil-stone, shaped to fit the curve of the tool.

### Saws

Saws are divided into two classes: those for ripping and those used for cutting across the grain of the wood. In the rip-saw the teeth act like chisels and chop off the end grain, while the cross-cut tooth is shaped like a knife,

and has the same shearing action. The shape of the two types of teeth is shown in Figs. 4 and 5. The best modern

rough and jagged surface. It may be used, however, in making a diagonal cut, where it works much faster and nearly as smoothly as the cross-cut.

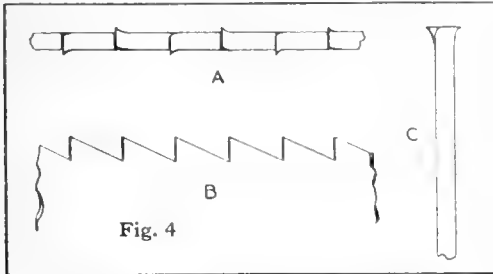

The teeth of a rip-saw act like small chisels to chop off the end grain of the wood

The cross-cut saw with its knife-shaped teeth, cuts slowly across the grain, leaving a smooth surface which for many purposes does not require any further finishing.

In all fine cabinet work an allowance should be made for chiseling or planing the cut surface, to remove saw marks. When ripping a board, keep the saw cut about 1/16 in. away from the line, and plane the edge true. To start a cut with the rip-saw hold the saw firmly and

saws are made thinner at the joint than at the heel (handle end) and the blade tapers from the cutting edge to the back. This stiffens the saw where stiffness is needed, and saws made in this way need very little "set."

The rip-saw is designed to work with the greatest efficiency when cutting with the grain of the wood. The shape of its teeth is the result of experience in combining such features as the strength of the tooth, the acuteness of the cutting angle, and the ease with which it may be sharpened. The steel in this saw is softer than that in many other wood-working tools, in order that it may be more easily filed and set. This necessitates frequent sharpening, particularly when the tool is used on hard woods. In general the rip-saw tooth has an included angle of 60 degrees, with the face at an angle of 90 degrees to the line of the teeth and to the blade. (Fig. 4.) This saw will not work successfully

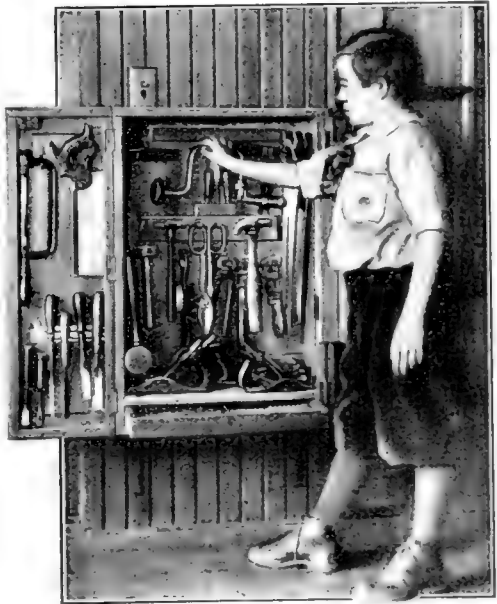

The arrangement of the tools in the cabinet back of the inner swing-door

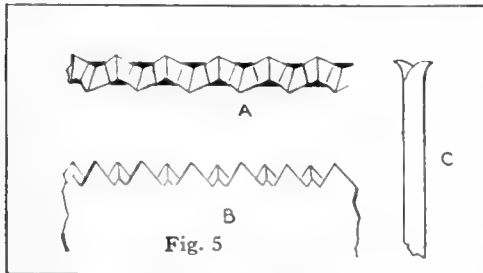

The cross-cut saw with its keen knife-shaped teeth cuts slowly across the grain

across the grain, as the teeth, having no shearing angle, tear the wood-fibers instead of cutting them, and leave a

move the teeth lightly over the edge of the board. Use the thumb of the left hand as a guide. If the saw is kept nearly parallel with the board it is not absolutely necessary to start with a back stroke.

A light, slow stroke is much more effective than a hard, quick one, which tends to buckle the saw and cause it to jam in the board. Sometimes, due to shrinkage, the board has a tendency to bind the saw in the "kerf," or cut. To remedy this, insert a screw-driver in the "kerf" and rub a little heavy oil or grease on the blade of the saw.

Filing and setting a saw correctly requires considerable practise; it is therefore a good idea to obtain an old or cheap saw on which to practise before attempting to sharpen the good one. A saw for this purpose can be purchased for ten

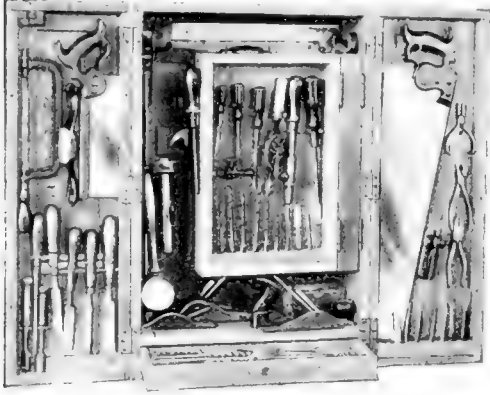

Fig. 6. A well arranged cabinet to hold all the necessary tools for hand wood-working

or fifteen cents in any store that handles cheap tools. The saw to be filed and set is first placed in the saw-vise, which may be two pieces of hardwood held in the vise, or a vise made especially for the purpose. The teeth should project about  $\frac{3}{4}$  in. above the top of the vise. "Joint" the saw by running a flat file over the points of the teeth from end to end, bringing all the teeth to the same level. Then "set" or bend every alternate tooth to one side, turn the saw and repeat this operation, following the original set of the saw. When this is done the saw is ready to be filed. Use a triangular file for both the cross-cut and the rip-saw. In filing the cross-cut saw, the file should be held at an angle toward the point of the saw sufficient to give the tooth a knife-like cutting edge. First file the alternate teeth, set away from the worker, filing with the set. When each tooth has been brought to a point, reverse the saw and file the remainder in the same manner.

The rip-saw is jointed in the same way as the cross-cut, but all the filing is done on the back of the teeth, and the file held at right angles to the line of the teeth and the blade. File with the set. When this operation is finished, rub the sides of the teeth lightly with the oil-stone to remove wire edges.

Auger-bits may be sharpened by filing the nibs and cutting lips with a bit-file. This must be done carefully in order that the bit may cut evenly.

Rub all tools with a piece of oily waste occasionally, to prevent them from rusting.

A cabinet in which to keep the tools can be easily made. A very well arranged one is shown in Fig. 6. The joints can be fastened with screws to simplify construction.

### To Make a Combined Drawing Table and Stand

A DRAWING board which when not in use may be set to a lower position and used as a stand will be found useful in places where the need for such a board is too infrequent to warrant the expense of a drawing table. The size of the board will depend on the drawings to be made. For ordinary use, 24 in. by 36 in. will be sufficient. Cleats of wood are screwed to the lower surface of the board about 3 in. in from its ends. The screws should pass upward through

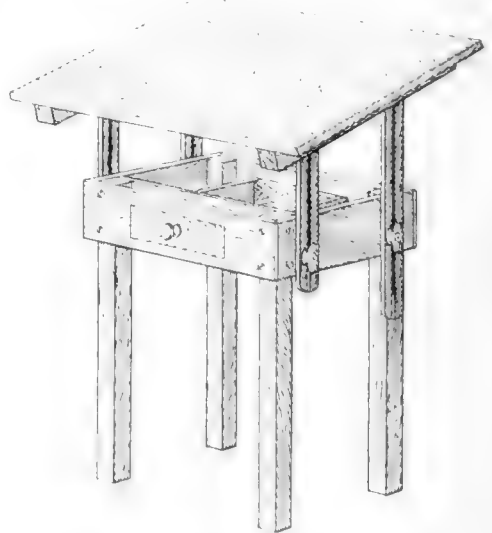

The drawing board, which is easily adjustable, forms a top for the table

the cleats and enter the board. Holes 1 in. deep are bored into the cleats to countersink the screw-heads. The cleats are made of stock 2 in. square.

The legs of the stand are about 28 in.

long and are also made of the 2-in. square stock. The common rabbet joint may be used for the front and side rails of the stand and the side rails are then nailed to the front and back rails with finishing nails. The rabbet joint may also be used for making the drawer.

The legs are screwed to the rails as shown. Four slotted bars are used for supporting the drawing board above the stand. Each bar is made of two strips 1 in. by  $\frac{3}{4}$  in. The front bars are 16 in. and the back bars, 24 in. long. Select two strips which are to constitute one bar and place small blocks of wood 2 in. long between them at their ends and nail the strips together.

Screws pass through the bars about 1 in. from their upper ends and enter the cleats, thus supporting the drawing board.

When changing the adjustment of the drawing board, it is best to raise or lower one side, say the front or the back, at a time. Since the drawing board is supported at four points, it provides a more solid working surface than the usual type of boards supported at the center only.—C. H. PATTERSON.

#### A Spanish Windlass Made from Two Broomsticks

ROBINSON CRUSOE had a hard time of it moving his big canoe down to the water, but if he had known of the Spanish windlass his task would have been much easier. This windlass is used by lumbermen for pulling with ropes, the only apparatus needed being two stout sticks.

Two broom-sticks are strong enough to pull to the limit of the strength of a large rope. One end of the rope being tied to the boat, log, or other object to be moved, and the other end being made fast to something stationary, one of the sticks is held upright against the rope, with one end resting firmly on the ground.

The first stick should be held by the left hand on the near side of the rope. The other stick, held in the right hand, is next thrust down on the far side of the rope, and brought against the near side of the first stick. By pulling and bearing downward it is brought to the position shown in Fig. 1. By continuing to swing

the second stick, it is an easy matter to wind the rope on the first stick, as shown in Fig. 2.

The first stick, which serves as the windlass, will move toward the stationary object half as fast as the movable

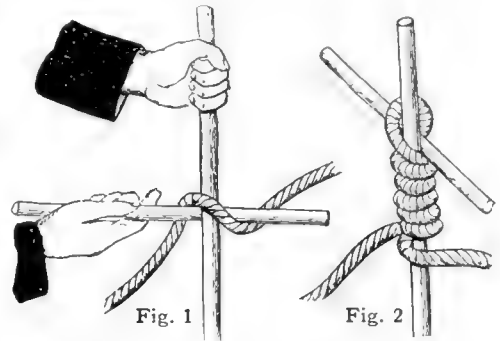

Manner of using two broomsticks as a windlass for hauling objects with a rope

object at the other end of the rope, and must be held approximately upright, so that the two parts of the rope will wind as closely together as may be. If these are not allowed to run apart, the tilting strain on the windlass will be comparatively slight.

Of course two can work the device much more easily than one, but one alone can do very effective work with it. The object cannot be moved any great distance at one operation, but if you unwind the rope after the windlass is wound full and take up the slack and repeat the operation, the probable distance which it can be moved becomes unlimited.—E. R. THORNTON.

#### How to Protect the Surface of an Enamelled Road-Sign

THE use of enamelled road-signs has become very popular, but although they are very attractive when in perfect condition they are anything but things of beauty when the enamel has begun to chip. There is a remedy for this evil, which will effectually protect the signs from serious injury from stones or other objects. Drill holes at the back of the sign, at the top and bottom. Attach supporting brackets for holding a thin wire mesh over the face. This will not interfere in the least with the reading of the sign.—C. H. THOMAS.

### An Ingenious Attachment for a Door-Lock

AN attachment shown in the accompanying illustration of an ordinary door-lock, permits of opening the

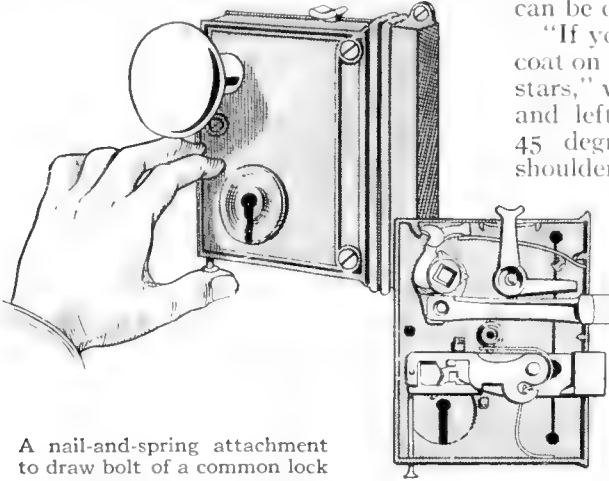

A nail-and-spring attachment to draw bolt of a common lock

lock from the inside, without the use of a key. The lock is not changed from its original form, and can be operated with the key in the usual manner if desired.

An ordinary wire nail and a small piece of clock-spring constitute the necessary parts. The spring is attached to the bottom of the lock in such a way that when it is released the bolt is withdrawn. The nail is inserted through the bottom edge also so that its upper end will lift the tumblers out of position and release the bolt.

### Finding Your Bearings at Night Without a Compass

AN English survivor of the South African War who was often sent on long-distance night reconnoissance has worked out a system whereby anyone can be right at home in the dark without compass or other instrument to aid the sense of direction. He worked out the exact movement and direction of the largest and most easily distinguished lights in the heavens so that the least scientific eye can recognize these signs by sight and the whole dome of the heavens becomes a vast compass.

If there were fire balloons or beacons placed in the heavens north, east, south

and west it would be easy for anyone to go in these directions by simply following the signs. Similarly, if one wished to go, say, a hand's breadth to the right or left of the beacons one could easily do so. The largest stars in the heavens can be depended upon in the same way.

"If you put the front buttons of your coat on the North Star or other direction stars," writes this authority, "your right and left breasts give you an angle of 45 degrees from the star and your shoulders a right angle. Also, it is only a matter of a little practice to be able to measure 15 degrees of horizon with your hand, so you can get any number of degrees to the right or left of your direction stars, and after a little practice it becomes second nature to recognize the points of the compass at sight, and you acquire the same sense of direction as Bushmen, Arabs,

and people who live far away from civilization.

"The North Star, Altair and Vega are all-sufficient night-guides during the spring and summer, and for autumn and winter the North Star, the sword and belt of Orion, Procyon and Regulus."

### To Make a Sanitary Cap for the Milk Bottle

TAKE a piece of flat spring steel, such as a piece of corset stay or clock-spring, if not too heavy,  $\frac{1}{4}$  in. wide, the length to be determined by the size of the milk-bottle neck over which it fits. Probably  $4\frac{1}{2}$  in. will be about the right length. Bend as shown in the illustration, making a spring clip to conform to the top of the bottle. Drill or punch a hole  $\frac{3}{32}$  in. in diameter in the center of the clip. Cut out a disk of transparent celluloid, such as is used in automobile curtains, of the right diameter to drop easily into the neck of the bottle but large enough so that it lodges on the ledge, in the neck of the bottle upon which the original paper cap rested.

With a punch or sharp-pointed knife, make three circular holes in this disk, one in the center  $\frac{3}{32}$  in. in diameter, another one  $\frac{1}{8}$  in. in diameter  $7-16$  in.



from the center, and the third 9-32 in. in diameter 7-16 in. from the center. Make these three holes in line.

Procure a snap fastener, such as is commonly used on women's clothing, and insert the ball end in the center hole of the celluloid disk. Place the spring clip on this and snap the top part of the fastener in place. If desired, a rivet and small metal washer may be used in place of the fastener, as this allows the cap to be taken apart. Be sure to have the ears of the clip high enough to allow the disk to rest on the ledge in the neck

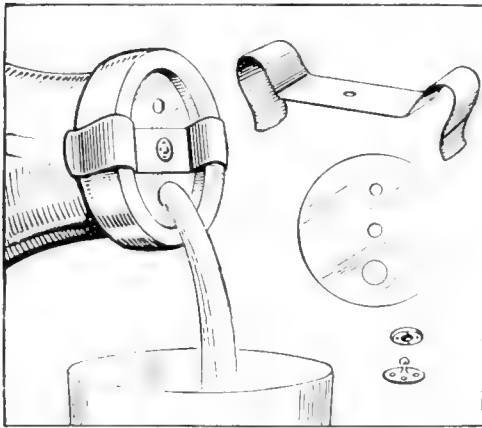

The cap in position in the bottle neck and the materials necessary to make it

of the bottle and use a tight fastener.

To use the cap, place it in position on the milk bottle and revolve the spring clip around the neck of the bottle, uncovering the holes in the disk. The milk pours freely from the large hole, while the other hole admits air.

### How to Lighten the Finish on Woodwork

**I**N treating woodwork to match another finish, it is frequently difficult to secure the right effect. If the woodwork is too dark, oxalic acid, diluted in water and applied with a cloth, will produce the desired result. It should be sand-papered before it has completely dried, with No. 1, and after completely drying, with No. 1/2. This method holds equally good in acid and water-stain. If varnish has been applied, it must be removed by a varnish remover (adelite), otherwise the oxalic acid will have no effect.

### Repairing Worn Wheels of a Carpet-Sweeper

**T**HE revolving brush of the ordinary carpet-sweeper is driven by the friction of the wheels on which the sweeper runs against driving wheels on either end of the brush axle. To insure good friction the peripheries of all of these wheels are covered with tightly fitting rubber rings. In time these rings wear out, or the rubber becomes hardened and loses its grip.

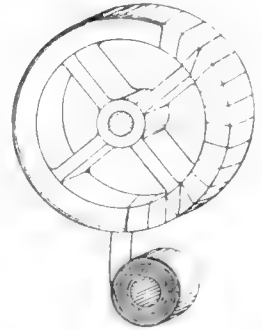

Adhesive tape on a sweeper-wheel

An efficient method of repairing a sweeper having imperfect or worn rubber rings is to cover the wheels with common electricians' tape such as is employed for covering joints in wire. The tape should first be wound around the periphery of the wheel until a covering nearly equal to the thickness of the original ring is attained. This should then be secured in place by passing the tape around the ring and between the spokes of the wheels. The gripping power of the tape is fully equal to that of the original rubber rings, and the sweeper will be good for service until other parts wear out.—GEORGE H. HALL.

### A Bottle-Stopper Made of Glass and Rubber

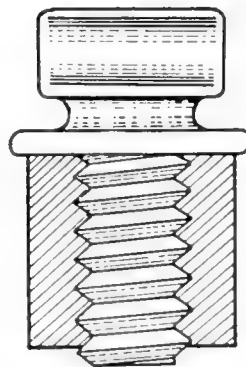

The glass part is threaded to screw into the rubber

**A** NEW stopper for bottles is composed of glass and rubber. The glass part is in reality a small stopper, threaded to screw into the rubber. It has a narrow flange above the rubber, and ends in a flat key-like knob for turning. When fitted into the bottle, a turn or two tightens it.

### Drying Negatives by Heat from a Kerosene Lamp

THE invention illustrated is a simple lamp heater for quickly drying photographic plates. In the old form of lamp heater, the hot air from the lamp is made to circulate in a chamber con-

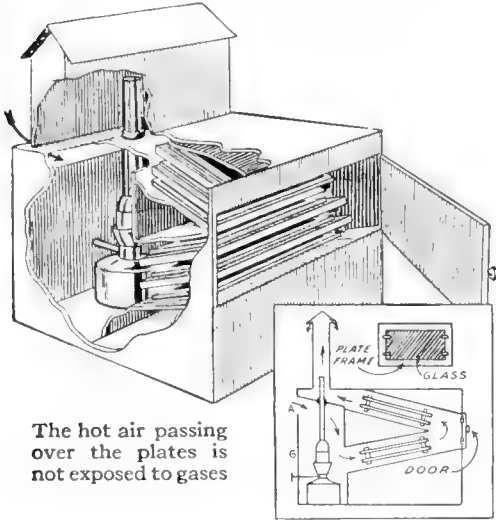

The hot air passing over the plates is not exposed to gases

taining the plates, but this exposes the plates to the gases formed by the combustion of the lamp and also to smoke, especially if, as often happens, the lamp does not burn well. In the new makeup, care is taken that the plates are exposed only to fresh air. As will be seen, the lamp is placed in the sheet-iron box, but it occupies a separate chamber. The lamp chimney projects up into a tube portion, and is prevented from overheating the metal by the use of an asbestos packing. The photographic plates are placed in two inclined chambers which open into the lamp chamber. The action of the lamp causes a suction in the upper tube due to the rising current of hot air, and this causes air to be drawn into the front opening *A*. The air passes up through the two plate chambers and out through the chimney. Only fresh air circulates in the plate chambers. Plates are first put in metal frames and these are slid into racks inside the chamber through the end door. If desired, a ruby glass front can be used at *G* so as to make the device useful as a dark-room lantern.

### Making a Scrap-Book Out of Old Ledger Covers

A SCRAP-BOOK can be made at home from an old ledger back, paper, twine, and glue, as follows: Take an old ledger and remove from it all pages, saving only the back. Next take about one hundred sheets of heavy type-writer paper (the number depends on the thickness of the ledger) and cut these to a size a little smaller than the back of the ledger. Between each of the pages place a thin strip of cardboard about  $\frac{1}{2}$  in. wide. Now take some sharp instrument, such as a large darning needle, and punch holes through the edge of the sheets of paper that contain the thin strips of cardboard. Place these holes about 2 in. apart. After they have been made, thread the needle with twine and sew them loosely together by passing the needle and thread in and out of the holes you have punched.

When the sheets are fastened together take a piece of linen cloth as long as the sheets of paper and about  $\frac{1}{4}$  in. in width. Where they have been fastened together wet the edge with glue and press it in the center of the cloth. After it has dried put the sheets in the ledger cover and fasten it there by gluing the cloth that extends out on each side of the sheets to the inside of the ledger cover. When it is thoroughly dried you have a scrap book that has cost you little or nothing.

### A Thumb-Tack Gage for a Paper-Cutting Board

THE drawing shows an accurate and easily applied method of gaging a cutting-board to trim exactly to size any number of sheets. It consists of a

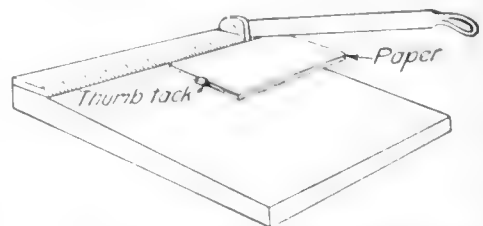

The thumb-tack can be set at any desired point on the cutting-board for a gage

thumb-tack stuck into the cutting-board surface at the right spot to hold the edge of the paper in place.—G. P. LEHMANN.

**A Photographic Printing-Box for Use with Electric Current**

**T**WO of the chief difficulties confronting the amateur photographer are getting a light just right for printing, and coloring glass a ruby which will not spoil plates or films during development. To overcome these I constructed a printing-box which worked very well. Of course, it can be used only where there is electric current.

Procure four boards 14 in. long, 12 in. wide and  $\frac{1}{2}$  in. thick. On one of these boards fasten two lamp sockets as shown in Fig. 1. Make the connections as shown, letting the two cords pass through holes in the board to the underside. In another of the boards an 8-in. square hole is cut, which is located by the dimensions given in Fig. 2. This hole is covered with a ruby glass 9 in. square, glued, pasted or fastened with strips of wood to make it entirely light-tight around the edges. These two boards serve as front and back; the other two are for the sides of the finished box. All of them are nailed together with brads to form a box with overlapping joints at the corners.

The top consists of a board  $12\frac{1}{2}$  in. square and  $\frac{3}{4}$  in. thick. The printing frame is placed on the center of this board and marked around the outside, making the outside line shown at A, Fig. 3. The frame is then removed and a line drawn  $\frac{1}{4}$  in. inside as at B, which is used to cut out the opening necessary for the printing window. Cut halfway through the board on the lines A to make it appear as shown in Fig. 4. This recess is for the printing frame to rest in during exposure. Secure another board  $12\frac{1}{2}$  in. square for the bottom and nail it in place, as well as the top board, to form the box, Fig. 5.

Paint the box a dead black on the inside and insert the electric lamps in the sockets. Connect the ends of the wires extending from the lamps to a lamp socket with a cord and plug, and the box is ready for use. It is best to have a switch in the circuit for turning the light on and off while changing papers from the frame. The hole in the top of the box is covered with some light-proof material, such as a cardboard or a book, when using it in the dark-room for

the purpose of developing negatives.

To use the box for making prints, place the negative and printing-out paper in the printing frame in the usual manner and drop the frame in the

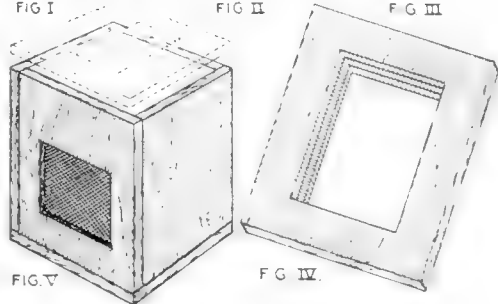
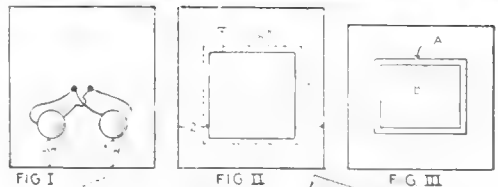
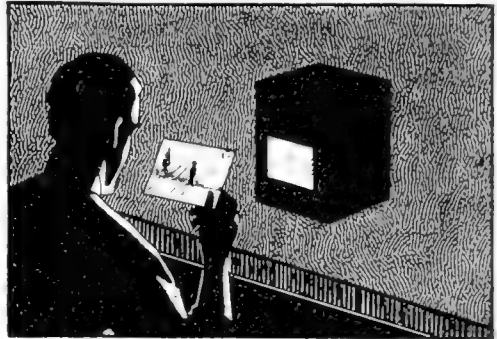

An easily made box for exposing developing papers; also for a dark-room lantern

recess cut out for it in the top board; then turn on the light by means of the switch. The time required to expose the print is found after repeated trials. By using a timing device one print may be developed while another is exposing.—HARRY WILSON.

**A Scheme for Keeping Pictures Hanging Straight**

**I**F two pieces of rubber are secured to the lower ends of a picture it will prevent it from assuming different angles on the wall when a jar tends to move it from its proper position. The pieces of rubber act as a frictional break and are effective in holding the picture steady.

Removing and Applying Valve-Stem Guides by Pressure

AFTER an automobile engine has been in use for a time, the guides or bearings for the valve-stems depreciate to such an extent that there is appreciable looseness between the valve and its bear-

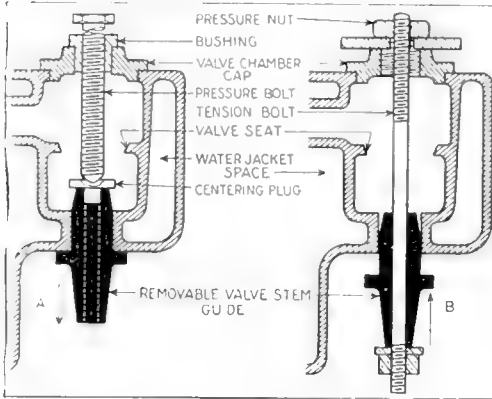

Pushing the valve-stem guide out of its place by screwing down a pressure bolt

ing. This not only results in noisy action but also interferes with proper engine operation, because air leaks in on the suction stroke through the inlet valve guides, dilutes the mixture and makes for unsteady engine operation at low speeds. On well designed engines, the valve-stem guides are removable and new ones can be easily inserted in place of the worn members.

A simple and effective method of removing is illustrated at *A*. The valve-chamber cap carrying the spark-plug is used as a basis for the device. A bushing to replace the spark-plug is screwed into the cap, this being tapped out for as large a bolt as possible. If the spark-plugs are 1/2-in. standard pipe size, a 3/8-in. or 7/16-in. bolt can be used to advantage. The bushing is easily forced out by pressure obtained by screwing down the bolt. This is superior to the ordinary method of driving the bushings out with a drift, because the seating or casting may be damaged by a careless blow of the hammer.

The method of applying the new guide is outlined at *B* in the accompanying illustration. A long bolt, the size of the valve-stem is used as a tension screw, this passing through a piece of steel or

iron bar resting on the valve-cap. Pressure applied against the guide by either the top or bottom nut will draw the bushing in place in the cylinder-casting without injuring it. The usual method followed of driving the bushing in is apt to result in breaking that member. While a lead or copper hammer is not so apt to mar the surface as the steel hammers are, still there is always danger of breaking the bushings. This is entirely eliminated by the forcing in process.

Quickly Adjustable Automobile Fan-Belt Fasteners

A NEW type of automobile fan-belt fastener has just been brought out. It is quickly attached, adjusted or repaired. The fastener consists of two metal parts, each attached to one end of the belt by means of three small brads. One metal part, the male, has two curved hooks which are slipped into two corresponding slots cut in the female half to make the belt continuous.

The fasteners are used with a special fabric belt and may be attached in a few minutes by means of the small brads. If the belt works loose on the pulleys, it may be taken off in a few seconds simply by unhooking the fasteners, whereas with a laced leather belt this takes several minutes and is a disagreeable job if one has to lean over a hot engine that has been running for several hours. To adjust the loose belt, the three brads of one of the fasteners must be removed, the fastener itself moved back a short

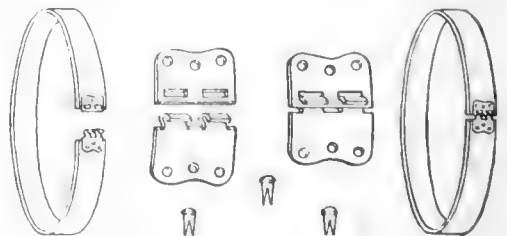

Any length of belt can be made up and adjusted by the use of the fasteners

distance on the belt and the brads pushed through the belt at other points.

The fasteners are made of cold rolled steel, the hooks being heat-treated but not made brittle, while the female fastener is left soft.

**Loading Small Luggage on the Outside of the Car**

A CONVENIENT "carry-all" may be constructed in the following manner and attached to any automobile. Obtain two strips of board 1-in. thick and 2-in. wide and cut them to the shape of the front and back fenders respectively.

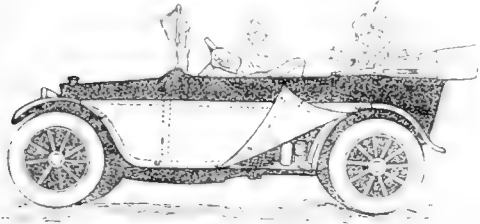

The carry-all takes up the space on the running board on the left of the car

Then purchase 20 ft. of blind stop and from that make a frame as indicated by the dotted lines in the illustration. This frame should be covered with black fiber board on the outside.

Drill six 1/4-in. holes through the frame and then holding the frame up to the proper position on the car, drill corresponding holes in the shoulders on the fenders and running boards on the left-hand side of the car. This leaves the "side-walk" side of the car free for entrance. The holes are practically invisible when the "carry-all" is removed. Six 3/16-in. stove bolts 2 in. long with split washers complete the device which gives sufficient room to store luggage. Camp equipment for ten people can be carried without loading the inside of the car.

A black oilcloth tucked in over the equipment keeps rain and dust from the contents and takes away the "bag and baggage" appearance. It requires only five minutes to take off or put on the frame.

Its cost is as follows:

- 2 curved pieces and blind stop.. \$.40
- Covering by trunk maker..... 1.00
- 6 stove bolts..... .05

Total..... \$1.45

It takes about two hours to make it. The entire contrivance can scarcely be noticed at a short distance from the automobile. A large quantity of duffel can be carried in it where it may be easily obtained when wanted.

**How Piston-Ring Defects Have Been Overcome**

THE highly successful behavior of the average automobile and motor-boat engine is due in large degree to the present state of development of the piston-ring. The function of the piston-ring is to form a vapor-tight chamber in which gas may explode, impounding its freed energy upon the piston-head which transmits this energy to the working parts of the engine. It is evident that the piston-rings must be as vapor-tight as it is possible to make them.

The earliest type of piston-ring was round, of the same thickness throughout, and was slotted to allow for expansion and contraction of the engine as it became hot or cold. The concentric ring was soon followed by the eccentric ring. The eccentric ring had a slot similar to the concentric type, but it overcame one of the defects of the older type—an unequal distribution of friction against the cylinder-wall. This was accomplished by tapering the thickness of the ring to the point at which the slot was cut. In overcoming the defects of the concentric ring, however, the eccentric ring acquired disadvantages almost as undesirable. One of these was that the unequal thickness of parts of the ring caused carbon to collect in the grooves on the

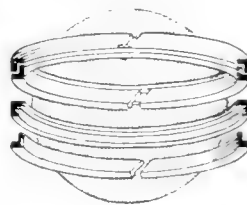

The rings are grooved to fit perfectly

piston-head into which the rings fitted. The great disadvantage of both these types of ring was their loss of energy, which resulted in their inefficiency. High compression was impossible, as the

gas would escape rapidly into the crank case below the cylinder. This defect, together with the undesirable features of the two types of rings, has been overcome in a new ring that is now in use. Two of the eccentric-type rings are grooved in such a way that they fit each other perfectly. Vapor cannot escape through either slot because a thin steel wall prevents it. Consequently, while the compression is high, the friction is equally distributed and the wear reduced.

### A Simple Tracing Method for Electrical Draftsmen

A TIME-SAVER for electrical draftsmen is shown herewith. The idea is to draw standard details on a paper, or still better, on a tracing cloth template, repeating each figure to each of the standard scales used in the office.

When these figures occur in tracing a drawing, the template is slipped under the tracing cloth so as to bring the proper figure, drawn to the proper scale, into position, when it is traced direct, saving the time necessary to make a

### Lightening Automobiles with Aluminum

THE most pronounced tendency in connection with modern automobile development is the reduction of car weight that has been made by all leading manufacturers in their recent models. One way of lightening the power-plant is to use small cylinders and obtain the power desired by increasing the piston speed and, of course, the number of explosions in a given time. The experimental work done in connection with high-speed motor design brought out the desirability of using light reciprocating parts. To attain this end, aluminum-alloy pistons were tried instead of cast-iron and these have been so successful that many new engines will be equipped with pistons of the lighter metal. Aluminum parts weigh about one-third as much as cast-iron ones of the same size, so the reduction of reciprocating weight materially reduces vibration and makes higher speeds possible.

All of the higher grade engines have always used aluminum crank-cases, but it remained for an ingenious designer to use aluminum for his cylinder-block casting in a 1916 power-plant. This engine is the nearest approach to the aluminum motor that has ever been made, since every part that could be made of that material has been constructed in some alloy of it.

Of course, there are numerous parts where it is not possible or practical to use aluminum. The crank-shaft, cam-shaft and connecting rods, for instance, must be of steel and very excellent metal at that. The valves and wristpins must be of steel and the fly-wheel of steel or cast-iron, because this part must be heavy to be effective. In this engine, even the cylinder-head casting is made of aluminum, the valves seating on cast-iron valve seats, made solid in the casting by the ingenious process of placing them in the mold and pouring the molten metal around them, when the cylinder-head is cast. The valve-stem guides are

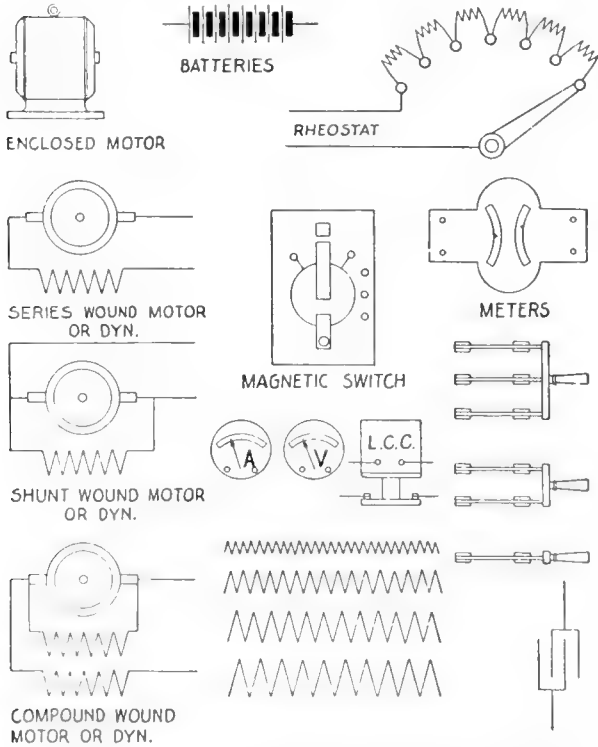

Stock drawings or templates to slip under tracing cloth as an aid in drawing in machine parts

scale drawing of that particular symbol. This idea may be extended as far as profitable, as the templates can be made up as a filler job.—FRANK HARAZIM.

### A Table-Mat That is Both Decorative and Protective

AN ingenious device for table-mats is an embroidered linen slip, inside of which is placed a sheet of white asbestos.

of cast-iron, pressed into the head casting; the piston-rings are also of that material. The heaviest parts made of aluminum are the pistons, cylinder-block, cylinder-head and crank-case. The pump, water connections, valve-motion cover and fan are also of aluminum. The valve-actuating rocker-arms are aluminum-alloy die-castings, the tappet-rods are also of aluminum alloy. Since aluminum is a soft metal, it would not be practical to run pistons of that material in cylinders of the same kind, so accurately machined cast-iron cylinder liners are pressed into the cylinder-casting to guide the pistons. An engine of this kind will weigh considerably less than one of the same size made entirely of cast-iron and steel, it being possible to save several hundred pounds' weight without any sacrifice of strength in an engine of fifty horsepower.

**A Bottle-Stopper Which Controls the Outpour**

A VERY good makeup for a special bottle-stopper intended to let out only a small portion of liquid such as perfume or the like, at a time, is shown here. It also makes it impossible for the stopper to be removed without

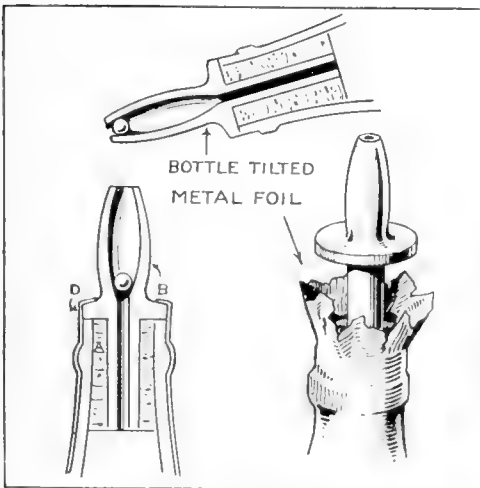

The ball within the stopper allows only a small portion of the liquid to pass out

detection. Into the cork portion *A* is fitted the metal part *B* which has a flanged portion so as to cover all the top

surface of the cork. The end is made as represented, the ball being placed inside in order to prevent escape of the liquid except in small portions. A cap of metal foil fits over the neck of the bottle and the upper flanged part of the stopper, so that to remove the latter necessitates breaking the metal foil.

**A Gage Which Tells the Amount of Moisture in Wood**

A GAGE that ascertains with accuracy the amount of water present in lumber has been put on the market. In

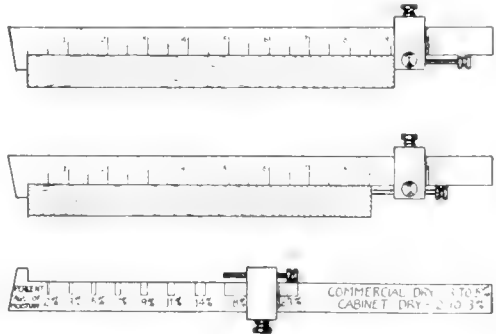

Gage used to determine the amount of shrinkage in wood in process of drying

appearance it closely resembles other commoner forms of gages used for other purposes, but its markings are different. A section of the wood to be tested is cut from the lumber and placed between the gage-jaws. The sample is then removed and thoroughly dried in a kiln. When the sample comes back from the kiln, it is again measured and the amount of shrinkage is noted.

**Mending Picture Frames with Laundry Soap**

A PICTURE may often be bought at a reduction in price because of a damaged frame. A badly marred or chipped frame can be easily and effectually mended with common brown laundry soap. Fill in the portions broken away with the soap, which can be molded with the fingers into any desired shape. Let it dry thoroughly and it will be as hard and strong as it is necessary for it to be. Gild or paint as the case requires, and the frame will look like new.—JENNIE E. MCCOY.



### An Easily Made Bathroom Cabinet and Medicine Chest

THE simple construction of this cabinet will recommend it to those who would take pride in making some useful piece of household furniture, but

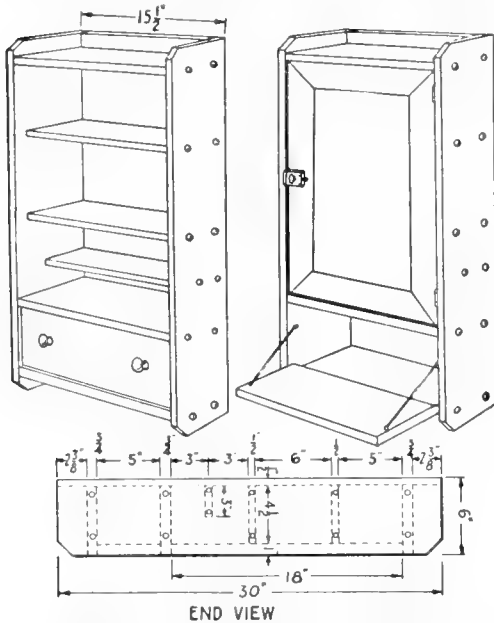

Medicine cabinet with mirror and drawer for toilet articles for the bathroom

who because of lack of skill have not attempted the articles designed for the experienced craftsman. It is made of oak. The pieces may be ordered from a planing mill planed, sandpapered and cut into the desired lengths. The mirror door is a standard size framed mirror, which can be purchased at any department store.

The upper or main cabinet is partitioned for medicines by two full-width shelves and one half-width shelf. Below the main cabinet there is a compartment for toilet articles. The front of this compartment is hinged to the bottom and lets down to form a shelf on which to rest the shaving mug or other toilet accessories. This front or door is provided with a small drawer-lock. The two knobs are added to relieve the plainness.

The following materials are required to make the cabinet: 3 pcs.  $\frac{3}{4}$ "x $5\frac{1}{2}$ "x14," top, bottom and bottom shelf; 2 pcs.

$\frac{1}{2}$ "x $4\frac{1}{2}$ "x14," upper shelves; 1 pc.  $\frac{1}{2}$ "x3"x14," lower shelf; 2 pcs.  $\frac{3}{4}$ "x6"x30", sides; 1 pc.  $\frac{1}{2}$ "x14"x30", back; 1 mirror, framed, 14"x18"; 1 pc.  $\frac{3}{4}$ "x5"x14" front of lower compartment; 1 cupboard-catch for mirror door; 1 pr.  $1\frac{1}{2}$ " butt-hinges for mirror door; 1 pr.  $1\frac{1}{4}$ " butt-hinges for lower door; 2 small wooden knobs for lower door; 1 small drawer-lock for lower door; 2 pcs. of dog chain for lower door.

The cabinet is put together with  $1\frac{1}{4}$ " round head blued screws; 46 are required, 22 to attach sides to shelves, top, and bottom, 8 for sides to back and 18 for back to shelves, top and bottom. The easiest way to assemble the cabinet is to tack the back to the shelves, top and bottom, using small nails, two in each. This will hold them in place while boring the holes and setting the screws. Then screw sides to back, shelves, top and bottom, boring  $\frac{1}{8}$ -in. hole for each screw. Then hang the two doors and finish with a stain.—T. H. LINTHICUM.

### A Clothes-Rack for Use Indoors and Outdoors

A GOOD clothes-rack for use in the line out of doors. It is made out of a few large galvanized wires and some light strips of wood. A pair of ordinary hinges may be used to hold the two parts together or a joint may be made like the one in the drawing, with a long wire and a half dozen screw-eyes. Half-inch lumber an inch and a half wide is strong enough for the frame. The dimensions should be about 18 by 36 ins. for each side. This will give 24 ft. of drying space, nearly as much as the ordinary clothes-horse which sits on the floor and

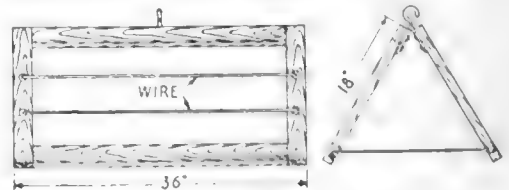

A V-shaped back for hanging laundered articles where there is a limited space

takes up more room. A screw-hook secured in the middle top enables it to be hung up in the house when full of articles to dry.—PAUL R. STRAIN.

**A Blacksmith's Hand-Blower Made of Wood**

A WOODEN blower for a forge is something of a novelty. A reader in the southwest sends us the accompanying drawing.

In the drawing *A* is the nozzle, *B* is the fan-casing proper, which might very

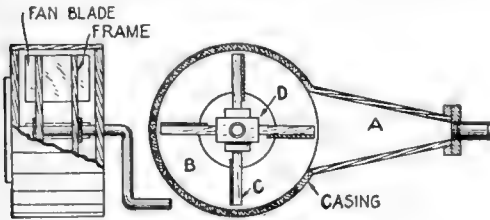

'A large hand-blower made of wood for use in connection with a blacksmith's forge

easily be a cheese-box. The fan-blade and frame are shown at *C*. *D* is the opening in one side of the fan-casing for the air supply. It has a batten across it to support the shaft on which the fans are fixed. This shaft has a crank for turning. The apparatus is cheap and practical, as a sheet-iron or wrought-iron pipe connection can be made between the blower and forge.

On account of the absence of multiplying gearing, the blower should be made several times larger than the geared blowers so common on portable forges. The dimensions and proportions, however, will have to suit the individual requirements.—LESTER SMART.

**Four Good Recipes for Acid-Proof Cements**

AN excellent recipe for an acid-proof cement contains the following ingredients:

- Crude, finely cut  
 rubber . . . . . 1 part by weight  
 Linseed oil, boiled . . . . . 4 parts by weight  
 Fire-clay . . . . . 6 parts by weight

Another equally satisfactory mixture requires the following materials:

- Rosin . . . . . 1 part by weight  
 Sulphur . . . . . 1 part by weight  
 Fire-clay . . . . . 2 parts by weight

The following mixture will resist all acid vapors (even nitric acid):

- Litharge . . . . . 80 lbs.  
 Red lead . . . . . 8 lbs.  
 Flock asbestos . . . . . 10 lbs.

These substances should be fed into a mixer, a little at a time, with 6 quarts of boiled linseed oil.

A good cement for dilute hydrochloric acid is the following:

- White China clay . . . . 1 part by volume  
 Fine white sand, or powdered quartz  
 and sand . . . . . 2 parts by volume

Mix the ingredients thoroughly, working them up with just enough silicate of soda, diluted with an equal volume of water, to make a paste. If a little fine casein is added to the silicate of soda, the mixture will be smoother.

**To Convert a Pair of Shoes into Slippers**

THE shoe illustrated has three separate parts, the upper *A*, body *B*, and heel *C*. To form the complete shoe, the heel is screwed on by the use of four screws. In order to attach the upper, there is used a set of lugs *D*, spaced all along the edge and these correspond to a similar set of lugs *E* on the body of the shoe.

The upper set of lugs fit exactly into the spaces between the lower ones, and a leather or any suitable lace is run the entire length of the shoe with the two ends brought out in front. The remainder goes through the eyelets in the upper. Again, when a slipper or low shoe is wanted all that is required is to take off the upper and the heel.—F. P. MANN.

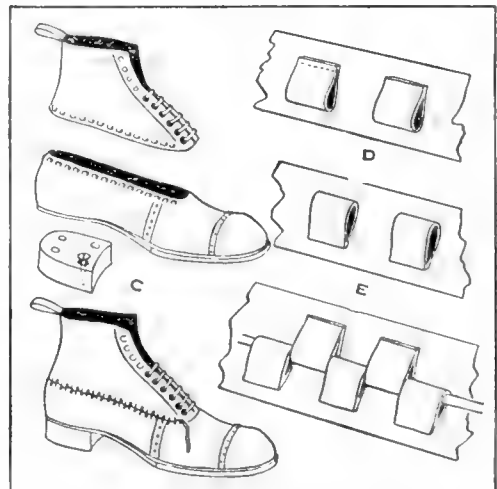

The heels may be unscrewed and the tops taken off or put on whenever desired

### Improved Method for Decorative Glass Blowing

A RECENT French patent describes an improved method for blowing glass in molds, so as to obtain ornaments in relief upon the surface of the object. A form having the shape of the bottle or vase has the decoration put on in wax; then it is covered by a suitable molding substance. By heating in the oven, the wax runs out, leaving the impression in the hardened mold. Then the glass is blown into the hollow mold, and the glass now takes the shape of the cavities so as to stand out in relief. The mold is carefully broken off the glass, and the design appears in sharp relief.

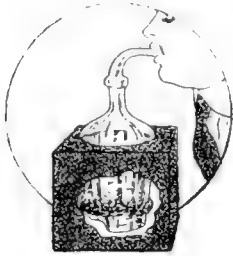

ing the impression in the hardened mold. Then the glass is blown into the hollow mold, and the glass now takes the shape of the cavities so as to stand out in relief. The mold is carefully broken off the glass, and the design appears in sharp relief.

### What to Do with Small Pieces of Bath Sponge

HERE is a small economy for cleanliness and comfort in the bath. As is well known, large sponges soon break up and become useless, and again they

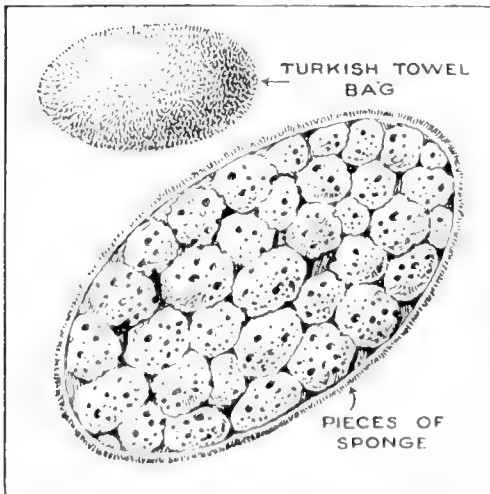

A bag made of Turkish toweling for enclosing sponges to prevent their clogging

are subject to being clogged up by impurities which are now recognized to be due to microbe growth within the

sponge. This is difficult to remedy in the case of a large sponge. A new idea is to assemble small pieces of sponge in a bag so as to give about the same shape as an original large sponge. The bag can be made of Turkish toweling or any suitable material. Thus all small pieces of sponge can be utilized and can be kept clean easily.

### A Draftsman's Inkstand Which Will not Overturn

A ROVING ink-bottle on a drafting-table is a treacherous thing. To keep it from turning over, take a piece

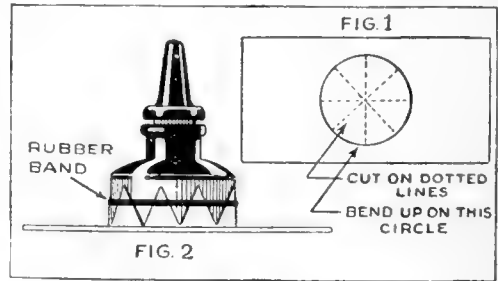

The stand holds the ink-bottle in an upright position and prevents it from tipping

of tin or cardboard 3 in. wide and 5 in. long, cut as shown in the drawing, and bend up the tips. Push the bottle up into this circular grip, and the tin tips will hold it securely. If cardboard is used, put a rubber band around the tips. The bottle will be held securely and cannot be accidentally overturned.

### Renovating Nickel Plate with Tinfoil and Solder

WHEN touching up worn or rusted nickel parts, first remove all rust and dirt with a file or emery cloth. Heat the surface and cover it with a soldering flux. When sufficiently hot, rub a stick of solder or some pieces of tinfoil over it, until it is thoroughly tinned. After cooling, the surface may be smoothed up with fine emery paper and a piece of flannel.

This method may be used successfully on motorcycle handlebars. It is hard to tell the difference between the lead and nickel, when the work is properly done, and the lead will wear longer.

Keeping Rats Out of the Corn-Crib

**S**PECIALISTS in rural engineering have worked out plans for a corn-crib that will aid in the drying of corn and protect it from the rats. There are usually two cribs in the complete structure, each 32 ft. long by 8 ft. wide, with a capacity of 1,000 bushels each.

The cribs are separated by a driveway 12 ft. wide and covered by a gable roof. The driveway may be of concrete or dirt. If the ground is well drained, a dirt driveway will answer. If the floor is of concrete it will serve as a feeding floor for hogs. A wood floor would harbor rats.

A concrete foundation is put in for all the walls. This should extend from below frost line to 6 in. above ground for the outer wall and 8 in. for the inner wall. The space between the walls should be filled with well tamped cinders or gravel, and on this a concrete floor laid. The difference in height between the foundations will give a 2-in. pitch to the floor towards the outer edge and drain off water that may beat through the walls. The cinders or gravel under

reinforced concrete with the surface troweled to a finish.

If a concrete driveway is used, 6 in. of gravel should be tamped down in a 4-in. floor with float finish laid on top. The iron sockets, which can be readily obtained on the market, should be set

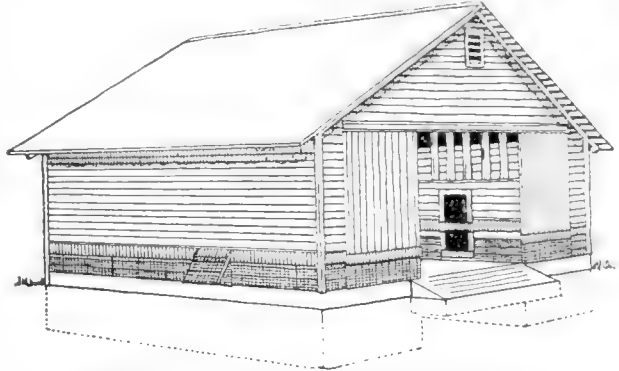

Double corn-crib with concrete floor, wire mesh and iron strip on lower part to keep out rats

while the concrete floor is being laid. The studs should be 2 in. by 6 in. The siding on the outer walls consists of 1-in. by 6-in. boards with upper and lower edges beveled at 45 degrees. They should be about 1½ in. apart. This permits entry of air, while the beveled edges lessen the danger of rain or snow beating in.

The siding facing the driveway need not be beveled, as there is no necessity for protection from rain at this point, and the siding should not be carried higher than 6½ ft. This permits the crib to be filled by throwing the corn over the boards. If the quantity is sufficient to fill the crib above this point, additional siding can be hung on 20-penny nails driven into the inner side of the studs. The boards have holes at proper intervals to fit over the spikes and are held in place by the pressure of the corn.

The rat-proofing is a feature which the farmer cannot afford to neglect. Wire netting of ½-in. mesh is put on all sides of the corn between studs and siding and carried to a height of 30 in. above

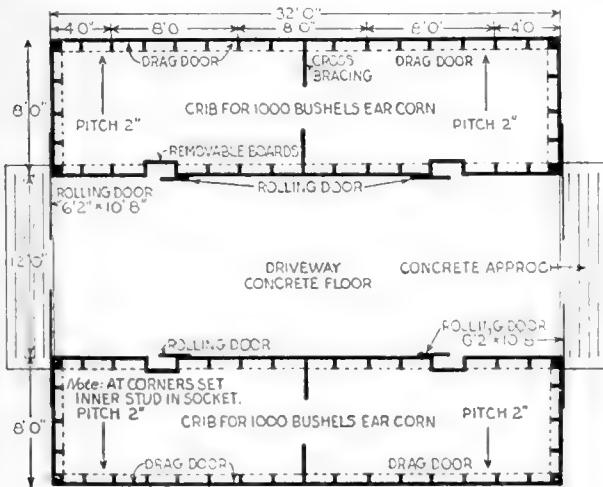

Floor plan of the double corn-crib in which is incorporated a driveway made of concrete

the floor prevent moisture rising. The crib floor should be constructed of 4-in.

the ground or above the floor of the driveway. A strip of 8-in. galvanized iron is placed at the top of the wire and nailed to the outside of the siding. The bottom of the galvanized iron is 2 in. lower than the top of the wire, making a total height for the wire and iron strip of 36 in. all around. This strip will halt rats that may climb up the walls. The rat-proofing is put on the drive side of the cribs so that if the doors are left open rats will be unable to get at the corn. Care should be taken not to leave objects near the walls which would enable a rat to jump above the proofing.

Provision is made for four drag doors on the outer side of each crib and two rolling doors on the inside. The drag doors are so designed that the corn will roll out of them on the conveyer-belt of the sheller. The rolling doors on the inside are for access to the crib. They should consist of a frame completely filled with wire netting, with a galvanized iron strip at the same height as on the wall. The drag doors are made of siding nailed to the cleats with the wire mesh between.

Movable inverted troughs of slats are placed on the floor lengthwise of the cribs. These are in sections to facilitate handling and are designed to increase the circulation of air. As a further aid to circulation, movable shafts may be placed at the side or on top of the troughs. The shafts are constructed of strips 3 in. wide by 1 in. thick nailed vertically to frames made of material 2 in. wide by 1 in. thick. To hold the shafts in place they may be nailed to the cross-ties overhead.

#### An Easily Constructed Support for a Trap-Door

**M**ANY people have an out-door cellar, entrance to which is had through a trap-door. The hinges on the

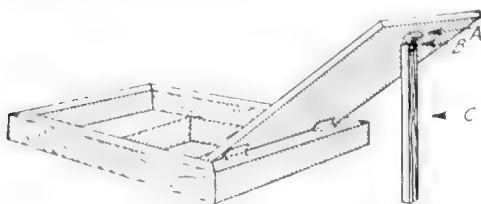

A support attached to a cellar door to prevent breaking hinges

door usually become bent and broken in a short time, because, when the door is opened and laid back, it seldom rests on the ground. Usually it touches the door-frame, which strains the hinges and causes them to break. To avoid this, fasten a hinge (*B*) on a block (*A*) near the outside edge in the center of the door, and to this hinge fasten a stick (*C*) that will reach nearly to the other side of the door, and see that the hinge works very freely. When the door is opened and let down on its back, the stick will swing out and support the door, as shown in the drawing, so that it will not touch the frame. When the door is closed the support swings back, and lies flat on the door.

#### Adjustable Overshoes to Prevent Horses from Slipping

**A** NEW horse overshoe has only one strap to buckle. No tools whatever are necessary. The two front links are



Easily fitted overshoes for a horse

made to tip in or out and fit any shaped hoof. Nothing projects which can possibly hurt the horse. The overshoes are made of malleable iron to prevent the calks from breaking off. The side calks prevent side-slipping entirely, so that the horse can trot with perfect

safety on icy pavements.

The use of overshoes is particularly recommended because they can be removed at will, so that a horse is not walking or standing on sharp points when the calks are not needed. New ones can be put on with the first ice or sleet, or even used in summer weather on bad roads without first visiting a blacksmith.

**F**OR sanitary reasons never paint a kitchen a color to hide the dirt. A color should be used that will show every particle of dust and dirt, which will then be removed for the sake of appearance.

**To Make a Dry Battery Having Lasting Qualities**

FOR the person who cares to experiment, this type of a battery is a good example to try out; for, if properly constructed, it will last much longer than the ordinary dry cell. The container consists of a glass jar of a size suitable for the battery. Coil up a cylinder of heavy zinc plate to fit closely against the inner surfaces of the jar and line the

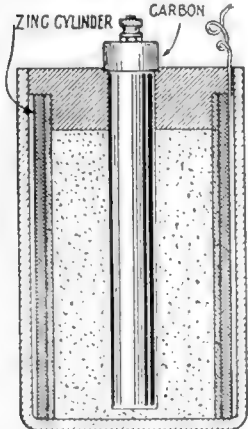

A Home-made dry battery cell

inside of the zinc with a good grade of thick blotting paper. A paste is made as follows: For the liquid mix together 3 parts water to one part muriatic acid. (In mixing acids and water remember to add the acid to the water slowly while stirring the water.)

The body matter for the paste is made of four parts powdered charcoal, 2 parts flour and 1 part plaster of Paris. These parts are measured by volume. Mix this powder with the acid liquid to form a paste. Procure a carbon from a discarded cell and place it in the center of the jar, then fill in around with the plaster to the top of the jar and finish by sealing with wax. After this stands for a few hours it will be ready for use.

**Insulating the Ground Connection in Radio Work**

A GOOD ground connection is of the utmost importance in radio working. If you use the gas, steam or water pipes be sure that they run out to the system of mains with good electrical conductivity. In some parts of the country it is customary to insulate gas or water pipes at the meters. Where this occurs a wire shunt should be connected between the house-pipes and the outside mains.

**A Weight and Pulley to Adjust Flexible Lamp Cords**

WHEN working around a machine it is necessary to have a portable light. A good way to make one is as follows:

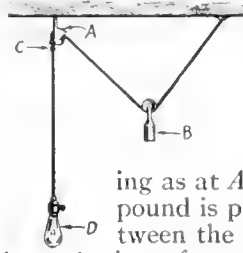

An electric lamp is let down from the ceiling to the floor. This wire is run through a pulley placed in the ceiling as at A.

A weight B of 1/2 pound is placed on the wire between the pulley and the outlet. A piece of tape is then wrapped on the wire on the outside of and below the pulley at C to keep the lamp from going up out of reach. When the lamp is to be used under the machine, take hold of the wire above the light D and pull it down. Afterwards the weight A pulls the lamp up into its former place again.

**To Lengthen a Shot-Chain on a Pull-Socket**

THIS simple operation will prove to be an economy to those handling these goods. It will be found that the small balls are split. These are opened up with a knife-blade until the edge of a cold chisel will take effect. They are then further opened up to release the small pin on the inside. This pin has a head at each end. One ball must be removed so that an extra pin may be had to start the lengthening of the parts. The pins are then put in to form a part



The small balls are split and may be opened up with a knife-blade and a chisel

of the chain instead of being just a fastening means. To do this properly the parts are laid out on a bench, and the balls clamped over the ends of the pins with pliers.—E. B. WILLIAMS.

### An Easily Made Self-Locking Device for Barn-Doors

THE drawing shows a self-locking device that is very useful on barn doors to prevent large animals from entering or leaving the buildings at will.

It permits a full amount of light and air to pass the doorway, and is easily set aside when not needed.

It is made as follows: Chisel a mortise in right-hand door-post  $5\frac{1}{2}$  in. long,  $1\frac{1}{4}$  in. wide and  $4\frac{1}{4}$  in. deep. Cut a slight vertical groove over the top  $1\frac{1}{4}$  in. wide. Then bore a  $\frac{1}{2}$ -in. hole at right angles with the mortise 1 in. from

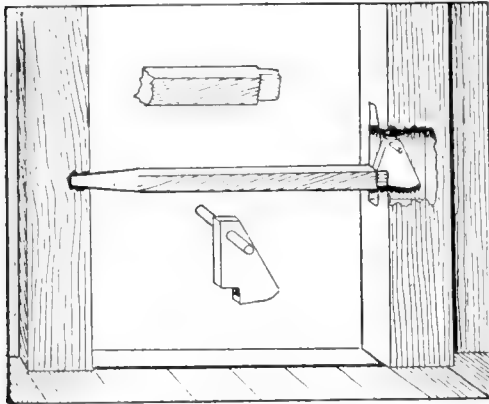

A self-locking bar across the barn doorway to keep the large stock in or out

the top and  $1\frac{1}{4}$  in. from the front for a pin. Place a wood dog of 1-in. oak in the mortise and insert pin through the door-post and into a  $9/16$ -in. hole in the dog, suspending it to swing freely. In the left door-post bore a  $1\frac{1}{2}$ -in. hole to a depth of  $1\frac{1}{2}$  in.

Select a bar of hardwood 2 in. by 3 in. and cut it  $2\frac{1}{2}$  in. longer than the exact width of the doorway. At one end make a tenon 1 in. long by  $1\frac{1}{4}$  in. wide, and nearly the thickness of the bar, rounding the two corners a trifle on the upper and lower sides, that it may be easily raised and lowered.

Round the opposite end of this hardwood bar to fit the  $1\frac{1}{2}$ -in. auger hole in door-post.—GALE PINCKNEY.

### Two Types of Inexpensive Depth Gages

ONE of the handiest tools for all mechanics is the depth gage. One can easily make a gage that is inexpensive as well as practical.

In the illustration the lower figure shows a simple gage made of  $\frac{1}{8}$  in. steel wire and a small pulley key; the measuring rod is locked by a small thumb screw.

The upper figure is an automatic locking gage of steel or wood, pressure on the split ends being required to release it. A small rod is split  $\frac{7}{8}$  of its length, and it is then sprung slightly so that friction is created great enough to hold it in place when in operation.—L. E. FETTER.

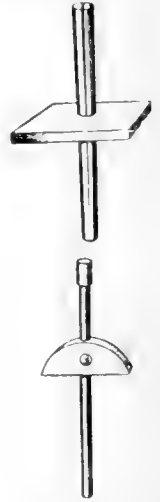

The upper figure shows an automatic locking gage of steel or wood. The lower one is made of steel wire and a pulley key

### Annealing Brass Pipe for Bending

IT is usually necessary in bending brass pipe or tubing to first anneal it to prevent the metal from cracking or breaking.

The customary way is to heat the pipe at the point where the bend is to be made by applying the torch to the outside of the pipe, turning the pipe until it is heated thoroughly and evenly all around.

A still better method is to place the pipe on an incline and place the torch so that the flame is blown into the end of the pipe. This will heat the pipe evenly the full length, after which it should be dipped in water. This will give the pipe an even color over its entire length.

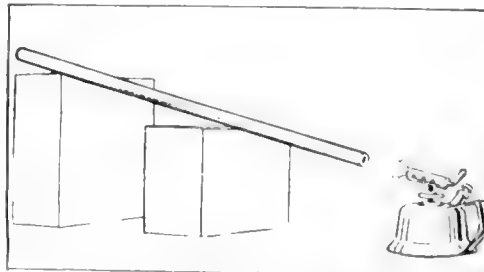

The flame is blown up into the pipe heating it evenly for the entire length



**A Watch-Carrier for the Motorcycle Handlebar**

EVERY motorcycle owner desires to have a watch placed on his handlebar, but the cost of a good watch-holder is entirely too expensive for the service it gives.

A thoroughly practical and easily constructed holder is made by removing the back of the watch and boring two small holes in it. A piece of nickel-plated brass or tin is then cut in a strip 1 in. wide and from 6 to 7 in. long, depending on the diameter of the bar. Two small holes are bored in the center of this piece, coinciding with those bored in the back of the watch, and out at each end to receive a bolt and nut when bent in a circular form.

This piece is then united to the watch-back and securely soldered. The watch-back is then pressed back on the watch and the metal strip curved around the handlebar and a bolt run through the two ends and tightened up, fastening it securely.

This makes a very attractive ornament on the machine, as only the watch itself is seen from the rider's seat. A little shellac or solder should be used when the watch-back is pressed on again to insure its safety.—N. S. MC EWEN.

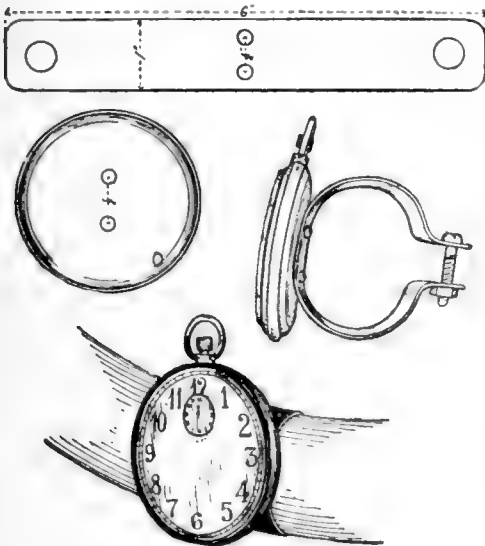

A metal strip is soldered to the watch and then curved around the handlebar

**Operating the Oil-Pump of an Automobile by Valve Action**

IT is seldom that the valves of an automobile engine are called upon to perform more than their usual function of admitting the mixture to the cylinder on the intake stroke and releasing the

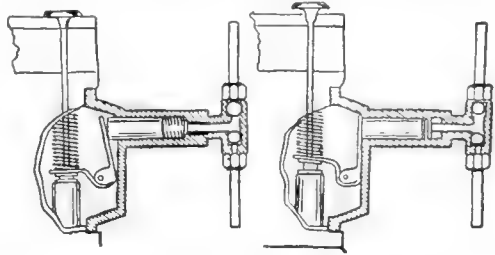

The upward movement of the valve stem and a strong spring operate the piston

burnt gas on the exhaust stroke; but the manufacturer of a new sight-feed oiler for a well-known light car has made use of one of the valves to actuate an easily-applied oil-pump.

The pump is operated directly from the valve through a rocker-arm which is raised with the valve travel. The rocker-arm is slotted to fit against the valve-stem between the valve-tappet and a special washer, and is pivoted. The upper end is in contact with the end of the pump-piston, and the reciprocation of this piston forces the oil to the engine. The upward movement of the valve-stem causes the rocker-arm to move the pump-piston outward, thus forcing oil out of the little pump chamber. A strong spring forces the piston back on the downward valve-travel to suck oil into the chamber and force it out on the upward stroke of the valve. Two simple ball-valves direct the flow of the oil to and from the pump.

**How to Make a Mallet from a Piece of Broomstick**

A MALLET can be very easily made by utilizing the remains of an old broomstick. The stick of the broom should be cut off to the length desired (about the size of an ordinary hammer). The head of the mallet is cut from 4 in. square lumber, such as oak or maple, or in fact any hard wood. Drill a 1-in. hole through the head.

### Making a Polisher for Table Cutlery from a Piece of Carpet

AN efficient cutlery polisher, as here shown, is easily made from a small board and a piece of carpet. To a board about 6 in. wide, 8 or 10 in. in length and an inch in thickness, with both long edges quarter rounded, is tacked a piece

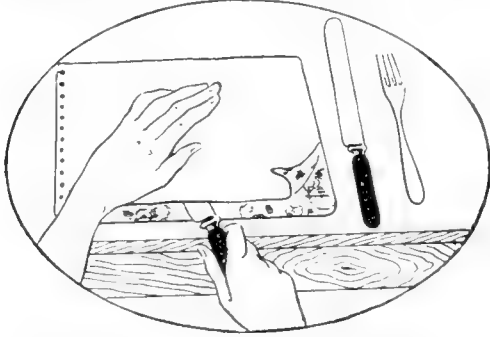

Powdered brick is sprinkled between the layers and the articles are rubbed over it

of carpet to entirely cover the board on one side and extend over the rounded edges. Over this carpeted board is placed another piece of carpet the same size as the board, but tacked fast only on one end. The nap surfaces of the two pieces of carpet should face each other.

Sprinkle a little cut bath-brick between the layers, moisten knife or fork and rub in and out, as shown in the illustration.—JOHN HOECK.

### How to Make Your Watch-Dial Luminous

THE first thing to do is to procure an ounce of calcium sulphide, luminous. The cost since the war is one dollar an ounce, but you can fix perhaps fifty watches with that amount. This element absorbs light, and after being exposed to any bright light for five minutes will glow with a purple light for about four hours.

Remove the crystal from the watch to be treated, and with a pen dipped in shellac go over the numerals and the hands. Some may prefer to make dots only at the numerals. Pour out the calcium on a clean piece of paper, dip your finger in it and press some on the moist shellac. Allow about five minutes for it to dry. The calcium not used may be returned to the bottle.

### Some Peculiarities of Different Styles of Eye-Glasses

WEARERS of eye-glasses often give offence to persons whom they meet in the street by looking, and apparently staring at them obliquely in a seemingly critical manner.

The offenders are usually near-sighted persons, who wear the old-fashioned biconcave glasses, and who have acquired a habit of looking obliquely at approaching persons, because they are thus enabled to recognize them at a greater distance. This peculiarity does not seem to be generally known. Far-sighted persons, on the contrary, see less distinctly when they look obliquely through their eye-glasses, if these are of the old biconvex form.

The strength of an eye-glass is inversely proportionate to its focal length and is reckoned in units called diopters. A glass of one diopter has a focal length of one meter, a glass of two diopters has a focal length of one-half meter, and so on. As one meter is nearly equal to 40 inches, the focal length in inches, according to which eye-glasses are still occasionally classified, can be obtained by dividing 40 by the dioptric number.

The effective strength of an eye-glass of the old flat form, whether concave (Fig. 1) or convex (Fig. 3) is slightly increased and the distinctness of vision is slightly impaired by looking obliquely

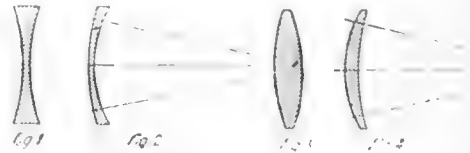

The old flat and convex forms of eye-glasses and the meniscus, or periscopic, glasses

through the peripheral portion. These peculiarities are nearly eliminated in the newer meniscus or periscopic glasses (Figs. 2 and 4). For far-sighted persons the new curved glasses are always to be recommended. Many near-sighted persons, on the contrary, prefer eye-glasses of the old flat type, which give them distinct direct vision of objects at a moderate distance.

**Benches for Electrical and Mechanical Machinery**

THE benches illustrated are designed to meet requirements where strength and rigidity are essential. A bench is shown in Fig. 1 on which medium weight electrical machinery has been tested for a number of years, without the bench showing any signs of weakening. The top and battens of this bench are made of 3-in. yellow pine, which can be bought dressed to size, at any mill. The top may be tongued or doweled together as shown in Fig. 3, and can be made the length designated, or extended to 12 or 15 ft. by adding another batten and two more pipe-legs.

The battens are fastened to the top with  $\frac{3}{8}$ -in. by 5-in. lag-screws; these lag-screws to have washers under their heads. It is necessary to bore the holes in the battens slightly larger than the screws, about  $\frac{1}{2}$ -in., to allow for the shrinkage and swelling of the top. In boring the top for the screws, use a  $\frac{1}{4}$ -in. bit, running the bit into the wood about  $\frac{1}{2}$  in. less than the distance the screw will penetrate; also cover the threads of the screw with soap before turning them in.

While the pipe used for the legs may seem a trifle heavy, it has been proved by experience that to eliminate vibration it is necessary to use this size. The pipe may be obtained cut to length and threaded on both ends to fit the standard flanges. Screw the flanges on the pipes until

the bench is the desired height, and parallel to the floor; then fasten them to the floor and to the battens with  $\frac{3}{8}$ -in. by 3-in. lag-screws.

Drawers will be found very convenient for holding tools and equipment. They may be made of  $\frac{3}{4}$ -in. maple, suspended from the bottom of the bench as shown in Fig. 1, which also shows the possible methods of construction.

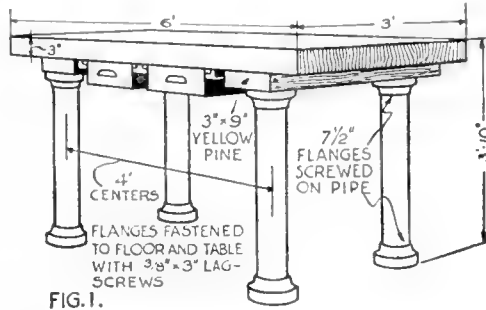

FIG. 1.

A wood-top bench supported by large gas-pipe posts which eliminate vibration

methods of construction. Finish the wood parts with four coats of oil-finish, made by mixing 1 part of boiled linseed oil with 2 parts of turpentine. Apply with a brush and allow it to stand about 3 hours; then rub off with a piece of cloth or cotton waste. Each coat should dry 24 hours

before applying the next. A finish of this kind preserves the wood and prevents warping.

Another bench for light machinery is shown in Fig. 2. The frame of this bench is made of 2-in. angle-iron, bolted together with  $\frac{3}{8}$ -in. by 1-in. stove-bolts. The holes for these bolts can be drilled, or if the iron is purchased from a construction company, they may be punched at the works for a small extra cost. The top and shelf are made of 1 1/2-in. oak or maple, screwed fast to the frame with 1 1/4-in. No. 12 flat head screws.

In making the top and shelf, it is advisable to use boards not more than 6 in. wide to prevent warping. The mill will supply this stock, dressed and jointed, ready to be glued together. A clamp, such as shown in Fig. 4, to hold the boards together while gluing, is easy to make.

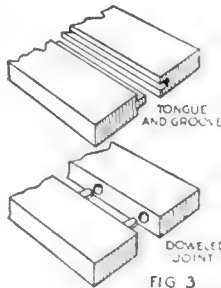

FIG. 3

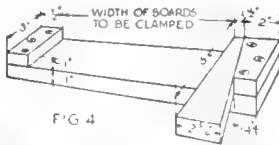

FIG. 4

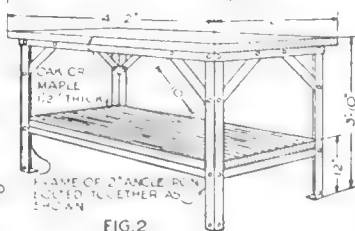
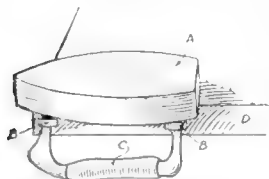

FIG. 2

A bench for light machinery. The strength of the joints is increased by doweling them together

### Utilizing an Old-Fashioned Flat-iron as an Anvil

A FLAT-IRON of the old cast-iron variety can be made into a useful bench anvil by simply stapling it to the work-bench as shown in the diagram, in which *A* is the body of the iron, *C* the handle, *D* the bench top, and *B, B*, staples to hold the handle in position.



Ordinary flat-iron fastened to the work-bench

If a slot is cut in the bench top, fairly heavy work can be done on it.—JAMES MULLEN, JR.

### Protecting the Gas Range with a Wind-Shield

DURING warm weather the draft from open doors and windows produces a bad effect on the flame of a gas range, sometimes blowing it out. A simple wind-shield may be easily constructed as shown in the illustration. The parts necessary are two pieces of molding, each about 2 ft. long—hardwood being the best material—and a piece of heavy cardboard.

The two pieces of molding are joined together as shown in the sketch at *A* to provide a substantial base. The holding means may be a thin wood strip, or a bit of tin nailed across the ends. In fastening this piece in place be sure to allow enough space between the strips to admit the cardboard. The shield can be shifted to any position desired to protect the flame and will prevent irons cooling from the draft. As it is not stationary it may be made to serve other purposes also.—MRS. JESSIE MCCOY.

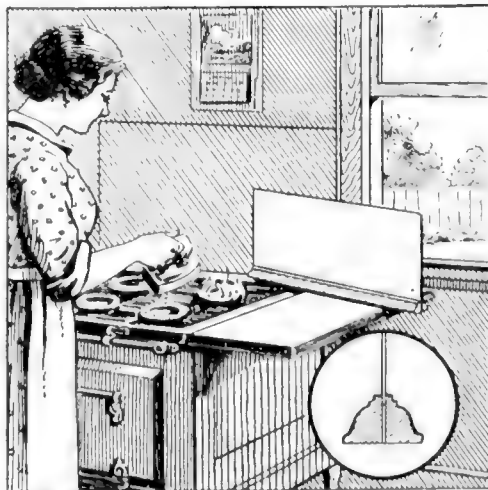

The shield may be set in any desired position in order to keep the draught from the flame

### Easily Attached Shock-Absorber for the Automobile

LIGHT cars have a tendency to jounce the passengers uncomfortably unless the springs are checked in their rebound by some shock-absorbing device.

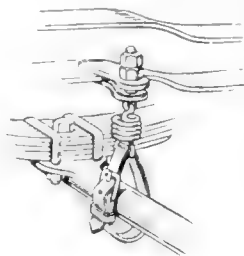

Most of the devices on the market require special work on the frame of the car or the springs; some need drilled holes. A new type of rebound check has now been invented which does away with the necessity of drilling holes in the frame, and which can be quickly attached to any type or size of car. The device consists of an adjustable strap attached to a strong, heavy coil spring, which is fitted with a special clamping device, to be attached to the inside of the frame chamber.

### A Simple Method of Filing Checks and Receipts

AS a safeguard against duplicating payments and as a matter of a receipt cancelled checks should be kept on file. Unless a special file is provided it is quite difficult to keep them in any kind of order. However, this can be done quite easily with a container made from boards of the ordinary check book cut down to the size desired and the metal back and rings of a narrow loose-leaf notebook. Two small holes are punched in the checks to permit their being placed on the rings. They are then transferred to the container in regular order, and if it is desired to look up a check it can be done without

disarranging the whole bundle. When one of the containers is filled another may be started. Where checks are numbered,

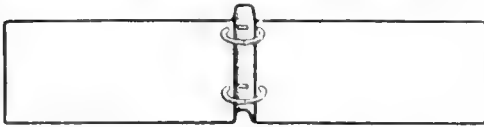

The metal back and rings of a narrow loose-leaf note-book used to file checks

mark on the outside cover the number of the first and last check—as 1 to 150.

The Indian's Method of Tethering a Horse

THIS method of tethering a horse may seem impossible at first thought, yet it is quite a simple matter.

A good sized knot is tied in the end of the rope, and a hole dug straight in the ground with a large knife. The hole should be small and quite deep. The knot in the end of the rope is pushed into the hole and the dirt packed down upon it. This makes the horse fast, and to loose him it is only necessary to stand directly over the hole and pull up in a vertical line.

The smartest horse cannot pull the rope from the hole. The only way for him to get loose is to grab the rope with his teeth and pull it out.

Keeping Your Ties in Good Condition

A GOOD "dry method" for taking wrinkles out of neckties is indicated by the drawing herewith. Just wrap the tie tightly around a mailing tube, spreading it out flat while wrapping, and if left in position for a day or so the wrinkles will disappear. A rubber band is most convenient for holding the tie in place, although a string can be used also.

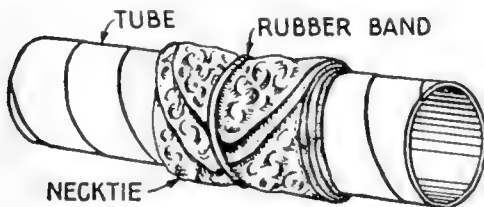

A mailing tube around which several ties may be wrapped to remove wrinkles

In case of the absence of a mailing tube, use a cylindrical bottle or anything of that shape.

This is much better than hanging the tie and "hoping" that the wrinkles will disappear, for here they are "forced" out.

As for capacity, almost any number can be wrapped on the tube, one outside the other.—N. G. NEAR.

A Canteen Made by a Junior Boy Scout

JUST to be equipped the same as his older brother with camping and traveling utensils, one boy scout

made for himself a canteen as shown in the illustration. The parts necessary are two pie pans and a strip of tin, together with a screw-cap like those attached to an oil-can or flask. These may be obtained from a tin shop.

The strip of tin is bent around to fit in between the flat upper surfaces of the pie pans, where it is soldered. The screw-cap is soldered into the strip of tin. Small pieces of tin are soldered on the edge of the canteen at intervals to form loops for a strap to pass around the center tin strip. By this arrangement a means is provided for carrying the canteen in the ordinary manner.

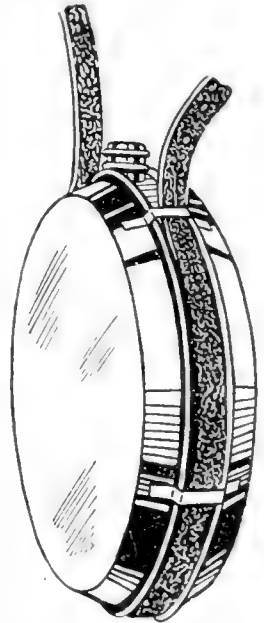

A Canteen made from ordinary pie tins

A Simple Way of Making a Canoe Unsinkable

SECURE two ordinary five-gallon tin oil-cans, place one under the thwarts at each end of the canoe and wire them in place. If the canoe is upset it can be turned over and even if filled with water will sustain the weight of two people without sinking.

### How to Avoid Excessive Oiling in Automobile Cylinders

**W**HEN the cylinders of a motor-cycle or automobile show the effect of excessive lubrication, the fault is often in the piston-rings.

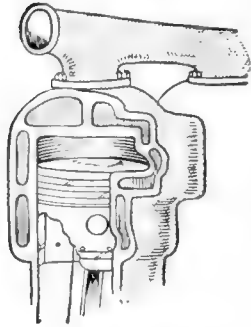

An extra groove in bottom of the piston

In order to permit the superfluous oil to run back into the crank-case, the following scheme has been found very effective.

Turn a narrow groove in the lower part of the piston, with the lower edge beveled. Then bore six or seven holes at equal distances around the piston, at an angle through

the groove. The sharp edge of the groove scrapes the inside of the cylinder clean, and the excessive oil returns through the drilled holes into the crank-case. It is self-evident that no piston-ring is fitted into this groove.

This method of avoiding excessive oiling will be found particularly efficacious in old-style cars, which have been run for a number of years.

### A Novel Experiment with a Lamp-Bulb

**A**VERY weird and interesting experiment may be performed with a lamp bulb. The materials needed are a motor or other means of rotating the bulb, at fairly high speed, and the incandescent lamp-bulb and its socket. All bulbs will not work in this experiment as the vacuum must be right. Most bulbs that are now manufactured have too high a vacuum, but if the experimenter has an old bulb made several years ago, it will probably work well.

The Editor of the **POPULAR SCIENCE MONTHLY** is always glad to hear from readers who have made simple and useful things for the home and the shop with their own hands and who would like to tell others of their own success. Articles from amateur mechanics, electricians and wireless operators are paid for on acceptance, promptly and liberally. But contributors must understand that only unpublished contributions, offered exclusively to the **POPULAR SCIENCE MONTHLY**, are desired.

The method of mounting the socket on the motor-shaft is shown in the illustration. The socket is threaded for  $\frac{1}{8}$ -in. gas pipe which is about  $\frac{3}{8}$  in. in diameter. If the motor-shaft is the same size and is threaded it can be screwed right on. If not, a hard rubber or fibre bushing can be used. The hard rubber bushing which is used with the socket is shown in the detail. This should be screwed into the socket and a hole bored in it below the set screw hole. A screw with the same thread as the set screw and long enough to reach the shaft through the bushing may be used for the set screw. The inside of the bushing can be enlarged with a rat-tail file to fit very tightly on the motor-shaft. The set screw should be turned up tight against the shaft through the bushing.

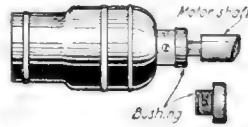

Mounting the socket on the motor-shaft

The bulb should now be placed in the socket and rotated, the hand being held against it. If the hand is damp it should be allowed to heat up by the friction until it is quite dry. The pressure of the hand need not be great.

If the bulb is right it should light up with a pale violet hue. It appears to work best if the hand is held on one side of the bulb only and does not completely encircle it. Sparks may be observed between the bulb and the hand and also where the filament touches the bulb. It is needless to say that the room should be quite dark.

### Prolonging the Usefulness of a Saucepan Cover

**W**HEN a saucepan cover seems useless because the little knob or handle is lost, push a cork part way through the opening and secure it by driving a nail 1 or  $1\frac{1}{2}$  in. long horizontally through the cork on the under side.

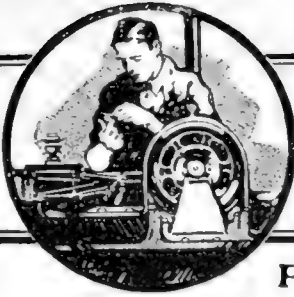

# The Home Electrician

## Practical Electrical Hints

### Spark-Plugs Tested Without Removal from Cylinders

THE device shown in the accompanying drawing enables motor spark-plugs to be tested without removing them from the cylinders. It consists of a

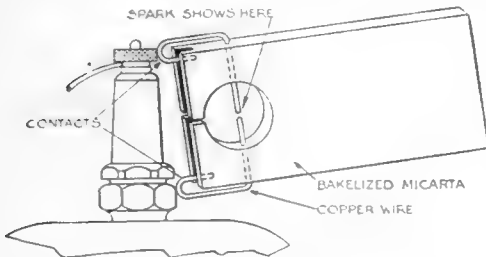

Connecting the parts of a spark-plug so as to test for short circuit

thin slab of non-conducting Bakelized Micarta  $3\frac{1}{2}$  in. long,  $1\frac{1}{2}$  in. wide and  $\frac{1}{8}$  in. thick, to one end of which are attached two short pieces of copper wire as shown. The wires are of equal length. One end is bent around with the end in a groove in the Micarta slab. The other is carried along the edge of the slab for a short distance and then bent at right angles and forced down through a hole in the slab to the center of a circular opening cut in the face of the slab as shown. The other wire is bent in the same shape, the ends within the circular opening being about half the thickness of a dime apart.

In operation, one piece of wire contacts the central electrode and the other the shell of the plug. If the spark is in good condition, enough of the current will be shunted through the two wires to cause a spark to jump between the adjacent ends of the wires. No spark will result if the plug is short-circuited and it will then have to be removed for inspection.—JOSEPH BRINKER.

### Converting a Plain Zinc-Gap into an Air Blast Spark-Gap

AN interesting suggestion for radio operators is presented herewith. The spark-gap has long been known as one of the most wasteful instruments in the wireless sending set. Many amateurs have been experimenting to reduce its losses. One object of rotary gaps is to prevent arcing because of the ionization of the air in the gap. This disadvantage may be overcome by the use of an air blast gap made from a plain zinc spark-gap. Remove the lower zinc plug and drill a  $\frac{1}{16}$ -in. hole through its center, as shown by the dotted lines in the drawing. Drill another hole  $\frac{1}{8}$  in. in diameter, on the side, so that it will connect with the first. A brass or copper tube is forced into this second hole on the side, as shown, to make a tight fit. Replace the gap terminal in the stand, so that the tube will project out at the back. The gap is connected in the circuit and a small rubber tube is slipped over the brass tube.

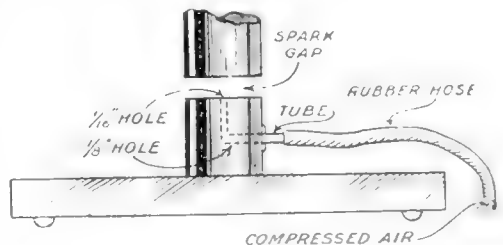

An air blast gap made from a plain zinc spark-gap as a means of reducing waste

The air may be supplied through this tube by a pair of foot bellows of the kind used by glass-blowers. If a reservoir is added the action becomes similar to that of an organ-blower.

A still better way may be to use a small tank filled with compressed air.



### Tapping Field Telephone Wires with a Pocket Connector

THE device illustrated is used in field work for tapping telephone wires where it is necessary to make a call on the line at any point. It is made from the body of the arms that form the ordinary machinist's divider. The sharp, tapering points are cut from a 9-in. tool, leaving square stubs 5 in. long. In the ordinary divider the arms are set apart to allow space for the spring. The arms must be bent to take up the space so that their inner surfaces come close together, then holes are drilled with their centers on the parting surfaces so that one-half the hole is in each member. Two of these holes are shown having different sizes to admit wires of different diameters. Small holes are drilled at right angles to these holes to intersect the half-hole in one arm and steel phonograph needles are inserted in them.

Another small hole is drilled through one arm and intersected at right angles with another, which is tapped to receive a knurled head machine screw. This is used for attaching a connecting wire to the receiver of the telephone.

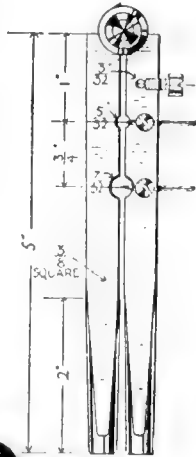

A small pocket device for making connections anywhere on a field telephone line

In ordinary use the connector is held on the wire by hand, but if connections are wanted for any length of time it is best to retain the wing with its nut and screw. In this case the wing should be cut off, allowing only a  $\frac{3}{4}$ -in. stub to project. The device is opened wide enough to clear the stub of the wing to admit the wire, then it is closed and the wing-nut set. The needles should not project too far or they will sever the wire.

### Strengthening the Static Field of an Amplifier

THE so-called audion principle, especially when used in telephone relays, has been applied to vacuum tubes built in a great variety of ways.

When the grid, or corresponding electrode through which energy to be amplified is led to the device, is placed close to the filament, the local battery current is usually controlled most efficiently. The closer the grid and the filament are brought together, the stronger will be the static field between them, and the better the amplification. It is necessary, however, to keep the two out of actual electrical contact. If current could flow directly from the grid to the filament the relay would be partially short-circuited and consequently would not work.

U. S. patent 1,169,422, issued in 1916 to A. M. Nicholson, shows the type of vacuum tube relay illustrated. The U-shaped electrode 1 is that through which the incoming feeble currents produce their effects, and takes the place of the grid in the more usual form of tube. The filament 2 is entwined about the U-electrode 1, being wound actually upon it. The two are kept apart by the insulating effects of a thin layer of nickel oxide on the forked conductor. The plates 3, 3 are connected with the local battery, and the whole relay structure is enclosed in the evacuated bulb 4.

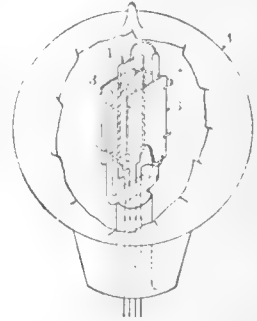

A new type vacuum tube relay

# Overcoming Troubles in a 200-Meter Wave Outfit

By R. H. G. Mathews

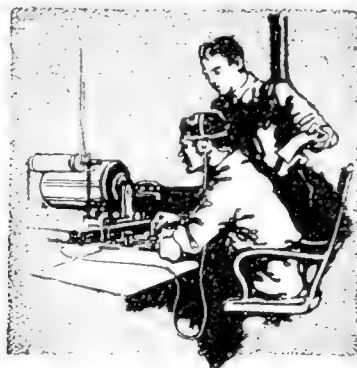

The following article won the second prize of Fifteen Dollars in the POPULAR SCIENCE MONTHLY'S Radio Article Contest. We would call it to the attention of wireless amateurs because it shows how, with a little ingenuity, a wireless amateur can overcome discouraging obstacles. We want more articles of this type.—EDITOR.

WHEN the radio law of 1912 went into effect, many of the amateur operators of the United States dismantled their apparatus and gave up experimentation with wireless telegraphy, thinking that a station which complied with that law could not do successful work. "Successful work" at that time in the amateur field meant transmitting 30 miles, with an input of 2 to 3 Kilowatts. Many amateurs whose stations comply with the present law, are now able to work over distances of from 800 to 1,000 miles with less than one Kilowatt input. To do this long distance work, using a short wave and low power, requires specially designed apparatus. A minimum of condenser with a maximum of inductance must be used in the closed oscillating circuit.

In order to obtain this condition, I designed and built a 43,000-volt, 1-Kilowatt, closed core transformer. Because of the use of this extremely high voltage, a condenser consisting of only 358 sq. in. of conducting surface, on opposite sides of  $\frac{1}{4}$ -in. plate glass sheets, is used. With this small condenser capacity, the primary inductance which may be used on a short wave is quite large, and consequently an easy transfer of energy from the closed to the open circuit is obtained.

At first, I made my condenser of the usual packed type, suspended in a tank of oil. I found, however, that my plates were continually puncturing, due, I thought, to my excessive voltage. I eventually discovered that the breakage was caused, not by direct puncturing, but by what appeared to be a crushing of the glass by a force exerted on it by the attraction of the charges of opposite polarity on opposite sides of each glass plate. When the plates were clamped

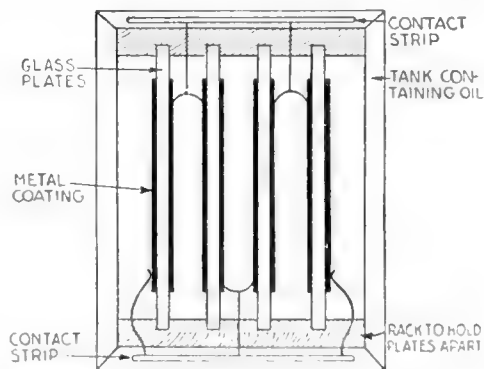

Fig. 1. Method of spacing plate glass sheets to eliminate breakage when immersed in tank of transformer oil

together the crushing strain exerted by this force was tremendous. I entirely eliminated this breakage by spacing

each glass sheet, with its two coatings of metal,  $\frac{1}{4}$  in. from the next sheet, in a small wooden rack, and then immersing the whole in a tank of transformer oil. See Fig. 1.

I was then troubled with a "dragging" spark. Judging from some of the sparks I hear every night, others are troubled in the same way, especially those who

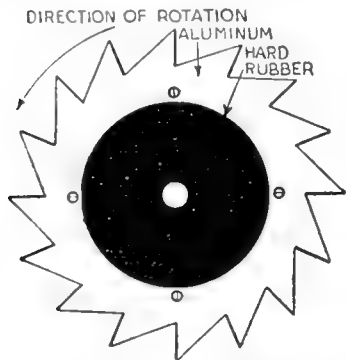

Fig. 2. Type of rotary-gap wheel which eliminated a very ragged sounding spark

are using high voltage transformers. I got rid of this trailing and cut out the ragged sounding spark by making my rotary-gap wheel as shown in Fig. 2. This spark break obtained by the use of this type of wheel entirely eliminated the pulling out of the spark, which had been the cause of my ragged tone.

Every little while, however, the armature of my motor would burn out on account of an electrostatic kick-back. I tried many kick-back preventers, and many different motors, until I finally tried an induction motor. This type of motor has no revolving coil to be burnt out, and consequently this problem was solved.

I was not yet rid of the troublesome kick-back effects, however, for whenever I sent for any considerable time I would burn out a few secondary sections of my transformer. To stop this annoyance, I made two secondary choke coils, as shown in Fig. 3. Each consisted simply of a single layer of about 50 turns of No. 18 wire wound on a threaded spindle of hard rubber. One coil was connected in series with each secondary lead.

The action of the coils chokes back the dangerous high-frequency surges originating in the condenser, yet allows the low-frequency currents from the transformer to pass through them with ease.

I have found that a low-pitched tone of about 480 sparks per second will carry farther and can be read more easily at a distance than the more common high tone. Other advantages of a low discharge rate are that time is given for the condenser to charge and discharge fully, and also that the points on the revolving wheel do not come opposite the stationary electrodes so rapidly that a back surge from the oscillation-transformer may jump across the gap, and be wasted instead of continuing in the aerial.

The most important thing in doing long distance amateur work is tuning. To get good results, the sending set must be in perfect resonance. The condenser must be of correct size for the spark-frequency used; the primary circuit must be tuned to exactly the wave desired, and the secondary circuit must be put into exact resonance with the primary circuit by the use of a hot-wire ammeter.

To adjust the whole set to resonance, a procedure such as the following should be used. The transformer should be disconnected from the condenser and oscillation-transformer, and a short straight gap connected across its secondary terminals. The aerial should be connected to one side of this gap, and the ground to the other. An arc is then started across the gap and the fundamental wave length of the aerial is determined by a wave-meter. For the best results it should be about 175 meters.

The smallest condenser that will give a clear spark should then be connected in the circuit with the rotary gap and oscillation-transformer primary. By the

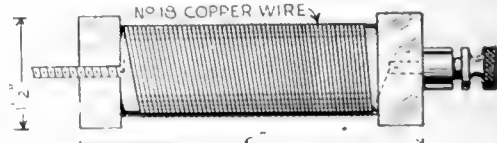

Choke coil consisting of a single layer of about 50 turns of wire wound on a spindle of hard rubber

use of the wave-meter, the number of turns of primary should be adjusted until the wave is 200 meters. The secondary of the oscillation-transformer should then be connected with the

ground and also with the aerial, in series with a hot-wire ammeter. The secondary should then be adjusted until the maximum radiation is obtained. The aerial and ground should then be disconnected, the condenser increased by one plate and the primary again tuned to 200 meters. The secondary is again connected and adjusted for maximum radiation. This should be continued until the condenser is all in use. A table must be made with spaces for entries of each set of adjustments, and the set finally adjusted according to the combination which gives the highest radiation.

The adjustment marked X would be used, according to the table, since it gives maximum radiation current. In receiving, I have noticed that the chief trouble is interference. The ability to tune out one station and still hear another whose wave is nearly the same as the first, is a coveted ideal, especially since all the amateurs are on one wave, all the commercials on another, etc. A considerable advance in sharp tuning comes with the use of an audion-detector, since with this type of detector the operator must tune sharply if he wishes to hear anything at all. Another useful way of obtaining sharp tuning is by inserting a variable condenser in series with the aerial. By using large inductance in the primary and small series capacity, it is often possible to eliminate much local interference and still hear the desired station readably, although perhaps not as loud as with the straight primary.

If a loose coupler is handled intelligently, and the coupling between its coils is adjusted carefully, it will get rid of a lot of interference. A small condenser placed in shunt with the loose coupler secondary is always of assistance on the longer waves, such as those from 600 or 1,000 meters up. A sample table is shown in Fig. 4.

Many amateurs pay too little attention to their ground connection. It is fully as important as the aerial. A ground which I have been using for over a year with the best of results is made of a 1/16-in. sheet of copper, 4 by 6 ft., buried 10 ft. underground. Connection is made to this sheet by a

No. 4 bare copper wire. This size wire is required by the Fire Underwriters, for both lead-in and ground-lead, and besides satisfying their requirements, it is a help towards good transmitting results on account of its high conductivity.

Many of the aeriels seen as one goes through the city are not constructed with any idea of what their wavelength will be, or of which type of aerial is best

Fig. 4. TUNING CHART

Wave Length	Power	Condenser	Primary Turns	Secondary Turns	Radiation
200 M.	1 K.W.	4-Sheets	6	14	1/2 Amp.
"	"	5- "	5 1/2	13	2
"	"	6- "	5	12	1
"	"	7- "	4 1/2	11	2
"	"	8- "	4	10	3
"	"	9- "	3 1/2	9	5
"	"	10- "	3	8	6 X
"	"	11- "	2 1/2	7	5
"	"	12- "	2	6	4

for the work desired, etc. For 200-meter work, the "T" type aerial is probably the best. It can be made almost double the length of an "L" aerial having the same wavelength, thus giving increased aerial capacity. A three-wire "T" type aerial 100 ft. long, not too high, has a fundamental wavelength which will be about right when used with sufficient oscillation-transformer secondary to bring the emitted wave up to 200 meters. Enough secondary may be used to insure good transference from the closed to the open circuits with an aerial of this kind. The wires should be spaced 3 or 4 ft. apart.

If an amateur's wireless set is given careful study in its design and careful work in its tuning and adjustment, there is no reason why, with operators of 1/2 by 1 K.W. input it should not do the long distance work that is being achieved by the few operators who have given their outfits careful study.

#### Removing Old Putty from a Window-Pane with a Hot Iron

A HOT soldering or other iron run over old putty will soften it so that its removal can be easily accomplished with a knife or chisel. Care should be exercised that the glass is not heated enough to cause it to crack.

### More Light on the Occupant of the Dentist's Chair

**A**N ADJUSTABLE lamp for dentists' use will doubtless be appreciated by the profession. In the one described the base, which is 18 inches in diameter, is turned from wood to match the office furniture. If not convenient to turn it, it can be made of two crossed arms, making a base with four feet. A half-inch pipe, 5 ft. 10 inches long, is fastened to the base by passing it through a hole

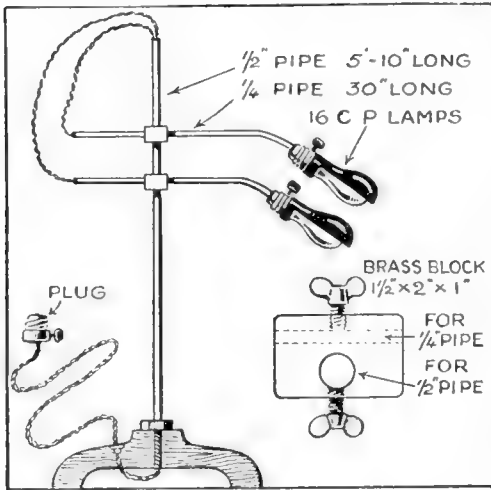

A dentist's light adjustable at any angle which furnishes light from two directions

in the center. A long screw, lock-nut and bottom nut and washer make it secure.

Two blocks are drilled so as to slide on this pipe, and thumb screws are topped to bear on the pipe. This permits adjustment at any height. Each block is drilled at right angles for the  $\frac{1}{4}$ -in. pipe arms, and is also furnished with a thumb screw. This makes movement in any direction possible. The arms are 30 in. long, and bent to an angle of 30 deg. about 4 in. from the end, which is threaded for an ordinary 16 C.P. lamp socket. The openings through base and the ends of the pipes are fitted with fibre bushings. The apparatus is wired as shown and fitted with screw plug for wall outlet.

This lamp, properly adjusted, will furnish light at any angle and from two directions at once, the advantage of which is apparent.—H. S. RUCKER.

### A Tool for Fishing Wires Through Small Openings

**O**RDINARY cork screws or screws made from a steel rod in a similar shape will make a very handy tool for



A tool with screw for pulling wires through small holes in insulation or walls

the electrician in pulling wires through small holes in insulation, walls, etc. In making a special tool, twist one end in cork-screw fashion so that its center will fit over the regulation size, No. 14 gage, rubber-covered wire.

The screw-end is inserted in the hole and turned around to make it take hold of the wire. The wire-end can be easily drawn through the opening. Holding the tool in a slanting position makes it take hold of the object to be removed quickly. The length of the tool will depend on the user and the kind of work.

### Magnet-Power of Toy Automobiles for Window Display

**W**HEN plug *P* is inserted it furnishes current for the motor, which in turn revolves the shaft and also the

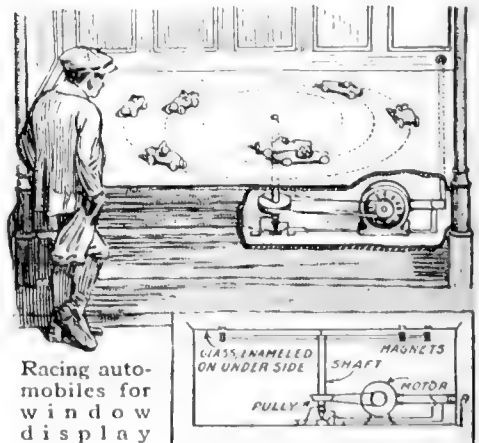

Racing automobiles for window display

magnets. The same current energizes the magnets. The little automobiles are made of soft iron and when the shaft revolves, taking the magnets with it, the cars follow in the magnetic field. Gears of any size can be applied so the magnets can revolve at different speeds, and even in opposite directions.—H. B. PEARSON.

# How to Become a Wireless Operator

## II.—Construction of a One-Mile Wireless Transmitter

By T. M. Lewis

(Continued from September issue)

**I**N AN article published last month, directions were given for putting together a little buzzer wireless telegraph set which would operate over a distance of a few hundred feet or even more. This small outfit was sufficient to demonstrate such of the principles of wireless telegraphy as should be known by every student and to send messages from one house to another nearby. The receiver was sensitive enough to pick up messages from commercial stations for some distance around, provided that a fairly long antenna wire was connected to it and properly tuned.

The amateur who has built and tested the buzzer set will want next to own and operate an outfit with which he can signal over greater distances. It is the purpose of this article to describe the construction of a wireless telegraph sender which can be made cheaply and easily, and which will give good strong signals at a suitable receiving station located as much as a mile or more away. The apparatus for the receiver will be taken up in later articles; the experimenter may well spend the intervening time in building his sender.

### *Transmitting Coil*

One of the first requisites in increasing the distance over which messages can be sent is to increase the effective power of the sender. The buzzer run from a couple of dry cells is not strong enough to make waves which will carry very far, so it becomes necessary to get an instrument which will do better. Such an apparatus is the ordinary induction or spark-coil. The amateur may build his own spark-coil by following the descriptions which are given in a great many books on experimental electricity, but in the long run he will find it cheaper and more satisfactory to buy one. An automobile jump-spark coil is about as good a small induction coil as can be obtained. Often it is possible to get one

at a nominal price from a garage or an electrician in the neighborhood. Even if purchased new from an electrical supply house, a good coil capable of giving a 1-in. spark between needle points in air will not cost more than three or four dollars.

There is also needed a Morse key, for sending the dots and dashes which make up the signal letters. This may be an ordinary telegraph key, which costs about seventy-five cents, or even a "strap" or signal key of the kind that sells for only twenty-five or thirty cents. If he desires, the experimenter may build his own key as shown in last month's article. For the heavier currents used in the spark-coil (as compared to the buzzer) it is a good plan to use larger key-contacts than those illustrated. They may be made by soldering copper washers on each of the contact screws.

To furnish power for the coil, the best thing is a 6 or 8-volt storage-battery.

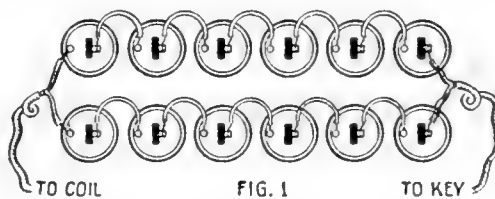

FIG. 1  
Twelve dry cells arranged so as to distribute the load between the two sets

This is quite expensive, however, and also requires occasional recharging. Satisfactory results may be secured by using 12 dry cells connected as shown in Fig. 1. With the battery arranged in this way the voltage is no greater than can be had from 6 cells, but the load is distributed between two sets of cells working side by side in parallel. As a result, the battery will last much longer than if only 6 cells were used. The vibrator on the spark-coil should be adjusted so that it buzzes freely, with a high-pitched sound, whenever the sending key is pressed. A spark-gap connected

across the secondary winding will break down whenever the vibrator is started buzzing, and a singing, clear spark will jump across as long as the key is held down.

### The Spark-Gap

A good spark-gap for the wireless sender can be made as shown in Fig. 2. Two battery zincs,  $Z, Z^1$ , which can be bought from any electrician, are cut off to about 3 in. in length, leaving the connection screws at the head of each.

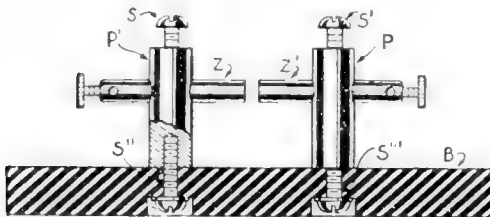

FIG. 2

A spark gap made from two battery zincs and a hardwood base boiled in paraffin

Holes to fit these a trifle loosely are bored through two stubby brass standards or pillars,  $P, P^1$ . A smaller hole is bored lengthwise through each pillar and tapped to take a 10-24 machine screw, such as  $S$  and  $S^1$ , to clamp the zinc electrodes in any position desired. Similar screws,  $S^2$  and  $S^3$ , pass upward through counter-bored holes in a hard rubber base,  $B$ , and serve to fasten the pillars in place. Hardwood boiled in paraffin may be used for the base, but rubber is better because it is a better insulator. The ends of the zinc rods, where they come close together, should be filed perfectly smooth and parallel.

### The Loading Coil

It is essential to use a "loading coil" with this outfit in order to get the best results, and to make the transmitter meet the requirements of the Federal laws governing the operation of wireless telegraph senders. This coil can easily be made by following the suggestions given in Figs. 3 and 4. Two square boards, about 12 by 12 in. with rounded corners, are first cut out of hardwood about 1 in. thick. A hole  $\frac{1}{4}$  in. in diameter is drilled at the center of each, and counter-bored to about 1 in. in diameter in the bottom of the baseboard

at  $C$ . Four  $\frac{1}{2}$ -in. holes are then bored in each, at points a little less than 2 in. from the corners, along diagonals as shown in Fig. 4. Twelve porcelain insulators of the sort shown in Fig. 5 are slipped over each of four  $\frac{1}{2}$ -in. hardwood dowels, whose ends pass through the  $\frac{1}{2}$ -in. holes just referred to and are cut off flush with the upper and lower surfaces of the top and base. A long  $\frac{1}{4}$ -in. brass bolt is passed upward through the central holes, so that its head drops into the counter-bored space in the base and its threads project a short distance above the top. A washer and nut put on the upper end will then hold the entire framework together.

Some No. 10 bare copper wire, or some stranded bronze tiller-rope or aerial wire, is to be wound spirally on the insulators. Referring to Fig. 3, the end is first wrapped around the upper front right-hand insulator  $A$  and spliced on itself. The wire is then led straight back to the top insulator of the back right upright, then across to the top back left insulator, as shown by the dotted line, then forward to the top front left insulator, and then to the next lower front right porcelain. The winding is continued as shown until the last insulator,  $B$ , is reached; there the wire is made fast by splicing, as before.

Two connected clips must be made or purchased. The spring testing clips sold by electrical supply houses are admirable for this, though anything of the sort will

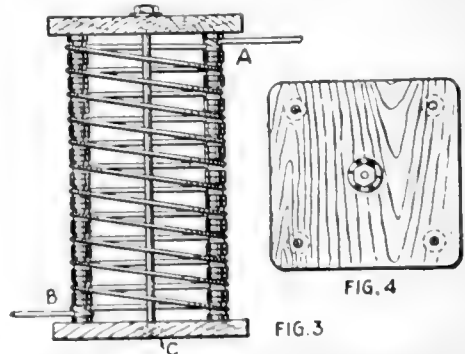

A loading coil to make the transmitter meet the requirements of the federal laws

do. Flexible wires are soldered to each of them, so that connection to any part of the bare wire-spiral may be made merely by clipping on the desired point.



The Aerial

The laws permit amateur wireless stations to use any wavelength up to 200 meters, provided that the wave sent out is sharp and pure. This means that the aerial wire system to be used with the sending apparatus described must not be more than 75 ft. long, measured along the conductor from its top to the ground connection. It is a good plan to use two wires about 50 ft. long running side by side to the top of a tree or chimney or specially built pole, keeping the wires about

five feet apart by fastening them at each end to a light wooden spreader. The top, and in fact the whole aerial, must be thoroughly insulated, if good results are to be secured. An excellent plan for preventing electrical leakage is to connect in series, with loops or rope, five or six porcelain insulators of the kind used in building the loading coil (Fig. 6). These are inserted between the spreader which carries the antenna wires and the rope halyard which is used to haul up the aerial. Similar strings of insulators must be used to guy out the bottom of the aerial. Where the lead-wire enters the house and connects to the instruments it should pass through a thick porcelain tube, as shown in Fig. 7.

The ground connection may be made by wrapping several turns of bare copper wire tightly around a scraped water or steam-pipe. The connection should be made at a point near to the sending instruments.

If no water pipes are available, a large copper or iron plate may be buried deeply in moist earth. As a rule, though, such earth connections are not as satisfactory as a pipe forming part of the town water system.

Connecting the Set

The several instruments making up the complete sending set must be connected up as shown in Fig. 7. The spark-gap should be adjusted with its electrodes quite close together—never more than  $\frac{1}{8}$  in. apart and at least half of the loading coil is to be

put in series with the antenna. Unless a large part of this coil is used the transmitter will not radiate pure, sharp waves, and its use will violate the law and make its operator liable to prosecution by the government. If the spark-gap is kept short and a considerable portion of the loading coil used, there will be nothing to fear so long as neither of the aerial wires is over 75 ft. in length.

Whenever the key is pressed, if the set is properly connected and adjusted, a bright, snappy, singing spark will jump across the gap. Each spark starts a train of high frequency currents oscillating back and forth in the aerial wires, and a train of electromagnetic waves is radiated into space. A suitable wireless receiver located

where a portion of these radiated waves will reach it, will pick up some of their energy and produce from it a sound which indicates the dot-and-dash buzzes of a Morse signal.

(To be continued)

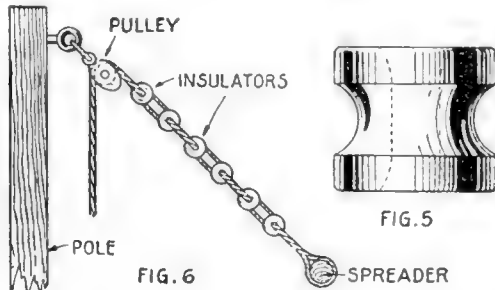
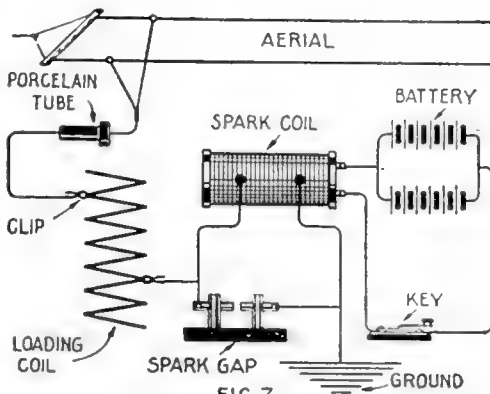

Fig. 5. Type of porcelain insulators  
Fig. 6. The insulators connected in series



Manner of connecting the several instruments making up the complete sending set

### Employing Kites to Support an Aerial

A DOZEN years ago there occurred an Army officers the idea of sending up a wireless aerial to a great height by means of kites, in order to increase the sending and receiving range of a field radio set. A few experiments were made, but without great success. In 1908 further attempts were made in this line, but again without especially encouraging results.

After the German steamship, Prinz Eitel Friedrich, had been interned at Norfolk, Va., last spring, a story leaked out as to how her captain (Herr Thierich-

make some further tests at the July maneuvers of the Militia in northeastern Massachusetts. Late one afternoon, at Newbury, Mr. Perkins sent up four of his huge hexagon kites. The aerial was attached to the kite line about half way between the kites and the earth, and hung vertically a distance of about 600 ft. to the ground. The lower end was attached to an ordinary  $\frac{1}{4}$ -k. w. field radio set, such as is used ordinarily with a 25 or 30-ft aerial. The swaying up and down of the kites caused the end of the aerial to be jerked off the earth or to coil up upon it, and consequently the operator was unable to tune, because of the constantly varying length of the aerial. He explained to Mr. Perkins that this was the cause of failure in many earlier kite experiments. With Yankee ingenuity Mr. Perkins soon put an end to the varying in length of the wire, and from that moment almost startling results were obtained.

The method by which the aerial was kept at an unvarying length is illustrated in the diagram, where *A*, *B* and *C* represent the kite line in three different positions corresponding to the verticals *D*, *D*<sub>1</sub> and *D*<sub>2</sub>. *A* shows the lowest and *C* the highest positions of the constantly swaying kites. By securing the vertical aerial wire to the ground when the kite line has reached its lowest angle, any further rise of the line occurs from the point *D* at the top of the aerial instead of from the point where the kite line is secured to the ground. Consequently, the point *D* always remains at a given height and the length of the aerial is always the same. It was this simple idea of holding down the kite line by means of the aerial itself that made the difference between success and failure, and made it possible to increase the range of an ordinary  $\frac{1}{4}$ -k. w. wireless set so greatly that it became in many ways the equal of a big tractor-set worth thousands of dollars.

As soon as the aerial was kept at an unvarying length in the experiment mentioned above, messages were received from the Filene Station at Boston, from the Battleship Georgia off Newport, from Arlington, Va., and even from as far away as Bermuda, a distance of over a thousand miles.

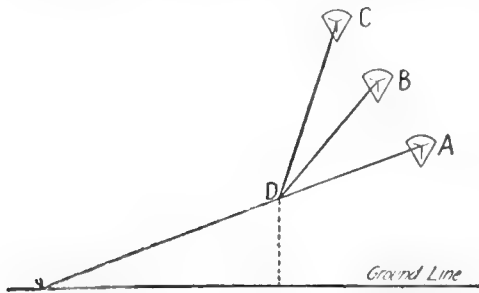
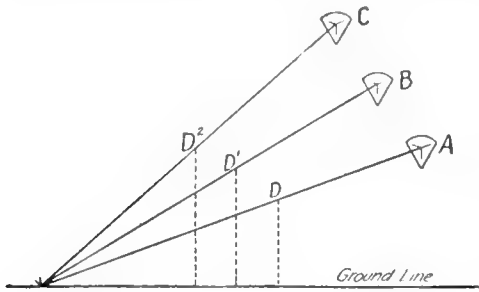

Manner of keeping aloft aerials with a string of kites on a line of unvarying length

sen) kept posted as to the whereabouts of enemy ships, and was thus able to avoid them for many months. He adopted the simple expedient of sending aloft an aerial supported by a string of kites. Such excellent results were obtained that a paper containing wireless news of the war was printed daily on board ship.

Recalling this use of kites by the German ship, Adjutant General Cole, of the Massachusetts Volunteer Militia, decided to resume experiments with a kite-supported aerial. Consequently he invited Samuel F. Perkins, of Boston,

Lieutenant H. C. Gawler, the chief radio inspector of the New England District, and Inspector Cheetham, the Marconi expert, were even more surprised when they began sending from their improvised station, for the replies they received showed that they were able to send a distance of 150 miles, or six times as far as would have ordinarily been the case. The normal record for a government field set is 44 miles, but it is probable that an ordinary field outfit can be made to send to a distance of 300 miles or more, when a kite-supported aerial is employed and if all conditions are favorable. It is possible to send up the kites and the aerial when there is very little breeze.

In last summer's Plattsburgh maneuvers the signal corps were shown that they could increase the range of their field set by about 200 miles if kite aeriels were used, and also that they could do this almost any day. When it is impossible to send up kites, it is proposed to use a small hydrogen balloon. A later test of the improved pack set at Fort Leavenworth demonstrated that it is now possible to send even farther than was believed possible.—STANLEY Y. BEACH.

### A New Spark-Gap for Wireless Telephony

IN order to transmit speech by wireless it is necessary to produce continuous waves, or, as a substitute, groups of electromagnetic waves at a very high

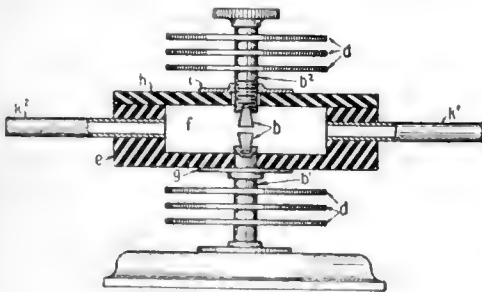

FIG. 1

A special gap with highly cooled sparking surfaces inclosed in a gas-filled chamber

will flow out from the sending antenna. The various forms of arc generators, when very carefully adjusted, or now familiar high-frequency alternators, can be used in this way. It has been suggested by various inventors that sparks occurring at very high frequencies might

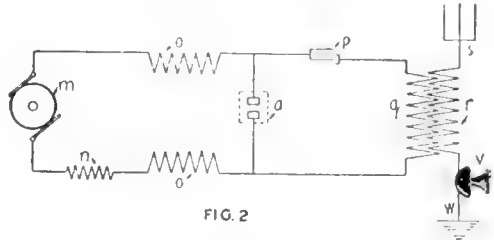

FIG. 2

A diagram showing how the telephonic sparker may be interposed in the line

also form a basis for radio-telephonic power generation; many forms of quenched and rotary-gaps for this purpose have been proposed.

In U. S. Patent 1,173,562 there is shown a special gap having small highly-cooled sparking surfaces enclosed in a chamber through which passes carbon dioxide gas. The inventor, W. T. Ditcham, points out that if large electrodes are used the spark will not remain sufficiently constant for the transmitted speech to be clearly articulate. In his new gap, which is shown in Fig. 1, the spark is restricted to the ends of the small plugs *B*, which are firmly set in the shafts *B*<sup>1</sup> and *B*<sup>2</sup>. These rods carry cooling flanges *D*, and are secured to the walls *H* of the gap chamber *F* by the flanges *G*, *I*. Fresh carbonic acid gas is fed through the tubes *K*<sup>1</sup>, *K*<sup>2</sup> and serves to cool the gaps.

Figure 2 shows one of the circuits in which the new discharger may be used. *M* represents a direct-current generator, of about 1,000 volts, which is connected through resistance *N* and choke-coils *O*, *O*, to the terminals of the gap *A*. The high-frequency circuit is composed of the gap, the condenser *P* and the primary *Q*; to this last-named coil is closely coupled the secondary *R*, which, with the microphone *V*, is connected between the antenna *S* and ground *W*. The two oscillation-circuits are not tuned to the same frequency as if measured separately, for the best transfer of

frequency. The transmitter should be uniform in operation, so that a practically continuous stream of radiant energy

energy from primary to secondary is secured with couplings as high as 40 per cent; this close linkage requires an apparent detuning for the best results. It is preferred to have the resonant frequency of the aerial circuit somewhat higher than that of the highly-damped primary.

Several other ways of relating the two circuits and the microphone are shown in the patent. In one of these the telephone transmitter is placed in an intermediate coupling-loop which contains no condenser and is therefore a periodic. Other minor variations are possible. The power leads may be connected across the condenser *P* instead of across the spark-gap, or several spark-gaps may be used in series. In operation the voltage and gap-length are adjusted so that sparks are produced at a very rapid rate; each spark creates a rapidly damped train of oscillations in the primary, and the energy of these is transferred to the secondary, where the result is a series of feebly damped and practically constant-amplitude high-frequency currents. The strength of these antenna currents is altered by the resistance changes in the microphone, and speech-waves are thus radiated.

#### Tracing Initials on Tools with Electricity

**T**OOLS may be marked very easily with electricity, which is easier than marking with acid. Screw the plug of an old cord into a socket, and wrap wire *D* around point *A*. Connect another wire with *B*, which is connected with the tool to be marked. The other

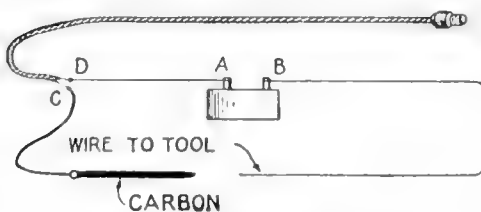

Connections to a rheostat and carbon for writing letters on steel

strand of wire *C* is connected with the graphite from a pencil or a piece of carbon from a dry battery. If carbon is used, care should be taken in sharpening it to a fine point, since it is extremely brittle. After insulating the whole ar-

rangement, the initials may be traced. The carbon makes deep, sharply-defined outlines. Graphite lines are shallow and rough. —H. WORTHMANN.

#### A Switch Operated by Pressure on a Footboard

**T**HIS type of switch will be found useful in a wireless station, especially for a test buzzer. It is operated

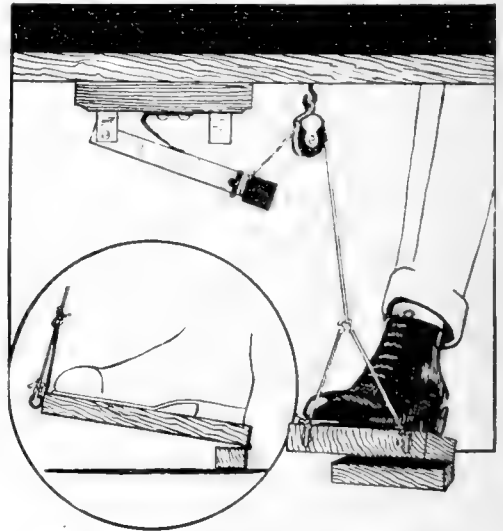

The switch is fastened to the underside of a table or shelf

by pressing on the footboard.

A common S.P.S.T. switch has a bent spring of stiff brass fastened to the base and so adjusted as normally to keep the switch blade away from the jaw.

The switch is fastened to the underside of the table or shelf. A stout cord is tied to the handle and passed over a pulley, and the other end is fastened to a hinged piece of board, as shown in the drawing.—JOHN B. RAKOSKI.

#### Differences in Time Between New York and Foreign Points

**E**XPERIMENTERS are sometimes confused by the difference in time used at various foreign points. France and England use time five hours ahead of New York, Germany's time is six hours ahead. San Francisco is three hours later than New York, and Honolulu time is 5½ hours slower than New York.

**Making a Crystal Detector from Cheap Materials**

THE base is a piece of oak about 2 by 3 in., having the top edge beveled to improve its appearance. A hole is drilled  $\frac{1}{2}$  in. from one end and in the center of block, to admit a short length of  $\frac{1}{8}$ -in. threaded brass rod, to be held in place by two nuts taken from an old battery. Next a small piece of thin spring brass *A*, 2 in. long by  $\frac{1}{16}$  in. at one end and tapering to  $\frac{1}{4}$  in. wide at the other is made. At the larger end a hole is drilled to allow this spring to be mounted on the upright brass rod by two thumb nuts, also taken from an old battery.

At the smaller end a hole is drilled, large enough to allow a piece of brass hatpin to slide freely through. Make a small tapered coil spring by winding fine springy wire on a match which has been whittled to a point and solder this spring at the smaller end to the piece of hatpin, which should be about  $1\frac{1}{2}$  in. long, so that the free end of the spring will be  $\frac{3}{4}$  in. from the point of the hatpin. Now place the pin, point downward, in the hole in the smaller end of brass strip. Solder the larger end of the fine coil spring to the brass strip so that

The pointer may be moved about over the crystal to find the most sensitive spot

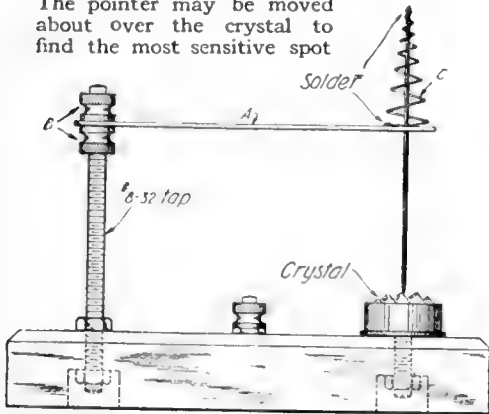

the hatpin floats freely within the hole.

Now you are ready to fasten your detector cup with crystal mounted in it, to the base so that the pointed end of the hatpin will make a light contact with the surface of the crystal. If the point of the pin does not touch the crystal its height should be adjusted by means of the thumb nuts *B*.

The fine coil spring *C* allows the contact point to be moved about over the crystal to locate the most sensitive spot, and also acts as a shock absorber to take up all ordinary vibration. The holder can be improved by mounting the crystal cup movably, according to any of the well-known methods.—RAY MAXWELL.

**Saving the Picture Show with a New Rheostat**

RECENTLY a new moving picture theatre found itself short a rheostat on its opening night, with no time to get

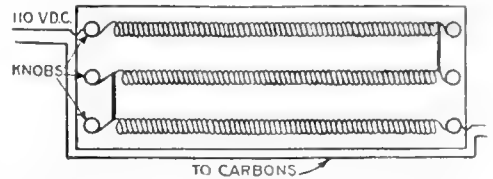

An emergency rheostat constructed for theatre use when one could not be obtained

one if the show was to start promptly. The man from the power-house was equal to the emergency, however, and made one, shown in the drawing, from the following materials:

One baseboard, 18 in. by 4 ft.; six porcelain knob insulators; six brass screws and three common coiled steel gate springs. These springs are  $1\frac{1}{2}$  in. by 16 in. coils. The baseboard is covered with heavy asbestos paper. The springs are connected in series with each other and the lamp carbon circuit. They are mounted with sufficient tension to open the spring far enough to prevent the coils from touching.

As shown in the drawing, they will pass about 30-35 amperes, without heating very much. This insures a nearly constant current, as there is not much change in resistance. More springs in series will cut down the current, and a reduction of the number will increase the amperage at the carbons.

**Wireless Telegraph Stations in the West Indies**

THE Cuban government has nine wireless telegraph stations in Cuba and on the Isle of Pines. There are two radio stations in Haiti. The respective governments have also equipped stations in Bermuda, Nassau, Curacao, Bonaire, Trinidad and Tobago.

### A Combination Front and Back Door Alarm-Bell

**F**ASTEN a common alarm clock on a block of wood, after removing the bell and legs. The block must be cut out to expose the back of the clock so

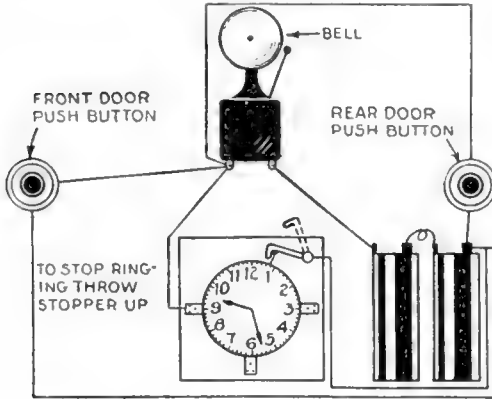

Diagram of the wires for alarm in connection with the front and back door bells

it can be wound. Two strips, about 4 in. wide, hold the block from the wall for this purpose. Three light angle strips hold the clock to the board. In the upper corner of the board place the contact hook, loosely pivoted and supported by a small brad driven into the board.

When the alarm is released the hammer makes contact with the hook, closing the bell circuit. This bell will ring until the hook is thrown back. The connection to the door-bells are ordinary. Partially run-down batteries from an automobile may be used for this arrangement, connecting a sufficient number in series to ring through the bell circuit.

### Insulating and Decorative Enamel for Electro-Magnets

**I**N half an ounce of wood alcohol dissolve one small stick of colored sealing wax; shake thoroughly at regular intervals to facilitate complete dissolution; put mixture in a tightly corked test tube or small vial. This mixture will keep indefinitely, and may be applied with a small camel's hair brush. Shake tube well before using. This is a quick drying and lustrous enamel.

### Electric Burner for Making Storage-Battery Connections

**I**T is well to have all connections on storage batteries fastened to the binding posts in a permanent way by soldering or lead burning. To do this work properly requires an oxygen burner, but the layman is not always sufficiently familiar with the use of this gas to make the proper application, and the apparatus is a rather expensive one to keep on hand.

The current taken from the cell is sufficient for the heat element and it is only necessary to make connections as shown in the illustration. Almost any partially experienced person can fasten the connector by lead burning.

To produce the proper amount of heat, an old carbon taken from an arc lamp is filed down to a small point to reduce the cross section area and is used the same as a soldering iron. The carbon is fastened to one terminal binding post of the battery with a large wire, using a piece of sheet brass around the carbon to make a better connection. Clean the binding post thoroughly to make a good weld. The carbon held on the binding post as shown quickly heats it to a point that will melt the lead; then the carbon is used in the same way



The current taken from the cell is sufficient to weld the connections to the binding-posts

as an ordinary soldering iron in making a good union of the parts.

To Change a Gas Lamp into an Electric Light

To change from gas to electric light on motorcycle headlights and retain the convenience of both, all that is necessary is to solder a candle-labrum socket to the old burner. Care should be taken to have the burner just the right height so that the lamp can be focussed properly.—F. G. DALY.

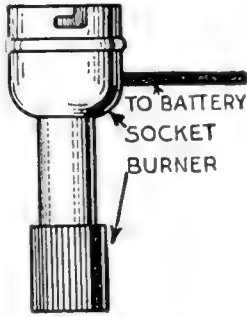

Best Wavelengths for Certain Distances

It has been figured out that for sending 700 kilometers the best wavelength is only 275 meters, in so far as the conditions between the two stations are concerned. For 1000 kilometers, the best wave is about 560 meters long, and for 1500 kilometers about 1250 meters. This computed result may be greatly modified by the characteristics of the sending and receiving antennas, however.

Lighting an Oil-Stove with an Alarm-Clock on Cold Mornings

No one really enjoys getting out of bed on a cold morning before the room is heated. And it is not really necessary; for with an oil-stove, an alarm-clock, a spark-coil (a 1/4-in. coil is sufficient), an old bell, some spring-brass, binding-posts and wire, an arrangement can be made to obviate it.

The oil-stove, with the hood turned back to expose the burner, is shown in Fig. 1. The wire may be ordinary 14-gage, asbestos-covered. The principal thing to be observed is that the distance from the wire *A* to the burner *B* is less than from the wire to the flue *C* (which comes down and covers the burner); otherwise the spark would jump from *A* to *C*, instead of through the wick to *B*. This distance is best determined by experiment. Over the wire *A* is a tin strip *F*, soldered to the tank to hold the wire in position. The connector

*E* may be removed by loosening the connecting screws; this permits taking out the tank without disturbing the spark-wire. Grounded to the frame of the stove is a binding post *D*.

The alarm-clock is mounted on a small board, as shown in Fig. 2. Have the brass springs sufficiently heavy and far enough apart to permit the key, when turning, to be held by the bend at the top of the spring. The important part of the mechanism is the relay, which turns off the current when the stove is lighted. A buzzer or an old door-bell is shown at *A*, Fig. 3, with the hook *B* soldered on to the end of the armature. A piece of sheet metal *C* is bent snugly around the screw *H*, which has a shoulder filed in it to prevent *C* from lying on the board. A piece of brass, *D*, is bent as shown, with a hole drilled for the screw *E*, which adjusts the tension of *D* on *C*. The spring *F* tends to pull *C* to the stop *G* out from under the spring *D*. The wiring is shown by dotted lines.

The action is as follows: The magnet *A* draws the armature *B* to its core. This releases the spring *C*, which slides slowly (its movement is regulated by the screw *E*) out from under spring *F*, causing a sliding contact of a few

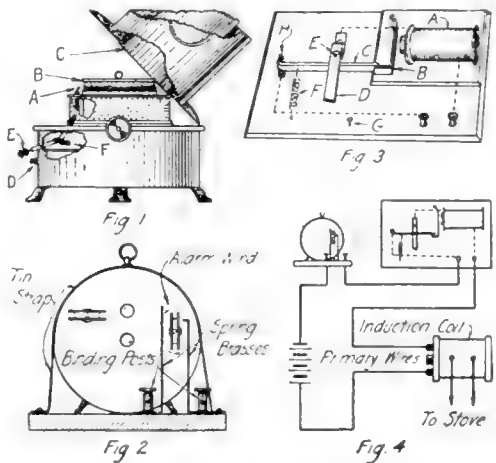

Wiring diagram and connections (Fig. 4) to an alarm-clock for lighting an oil-stove

seconds' duration, which ends in disconnecting the primary circuit. Dampening the movement of the spring gives the spark time enough to to ignite the cold oil.—ARTHUR F. STILSON.



# What Radio Readers Want to Know

## Calculating Wavelengths; Circuits of Audion Amplifier; Helix for Spark-Coil

E. B., Pittsburg, Pa., inquires:

Q. 1. I have a loading coil for an inductively coupled receiving tuner consisting of 625 turns of No. 22 enameled wire wound upon a tube  $5\frac{1}{2}$  in. in diameter, also a secondary loading coil wound with No. 27 enameled wire for a distance of 7 in. on a similar size tube. Approximately what is the wavelength of each?

A. 1. We cannot give the possible wavelength adjustment of a coil without knowing the constants of the circuit in which it is to be employed. It is easy to calculate the natural wavelength, but this data would be of no value for ordinary usage. The primary loader has inductance of approximately 12,400,000 centimeters and the other coil about 15,875,000 centimeters (15,875 microhenries). You of

but with .001 microfarads in shunt the wavelength of the circuit is about 7000 meters.

Q. 3. I require two loading inductances for this set to be adjustable to 14,500 meters in steps of 500 meters at a time; but they cannot occupy a space more than 8 in. by 5 in. by 3 in. Can you supply the data for the windings?

A. 3. We know of no method by which you can obtain this value of wavelength with a coil of these dimensions unless you wound it with very fine wire which, of course, would make them useless. Also keep before you the fact that there are no stations in operation that use the wavelength of 14,500 meters. Why not construct a set like that described by McKnight in the April, 1916, POPULAR SCIENCE MONTHLY?

Q. 4. Can you furnish me with the circuits of the single step Audion amplifier?

A. 4. See the accompanying diagram.

Q. 5. What is the voltage of the filament battery?

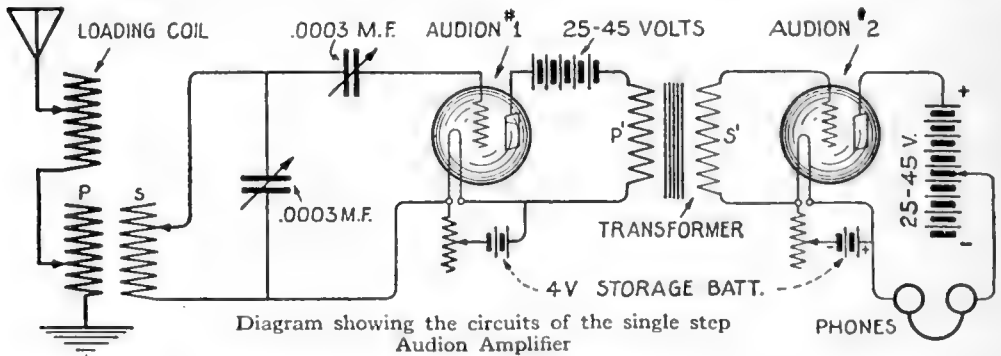

course understand that the increase in wavelength to be obtained with a given loading coil depends upon the natural inductance and capacity of the circuit in which it is to be connected; consequently, if these values are unknown, no general estimate can be given. You will then see that there is no such thing as a "2800 meter loading coil" even though manufacturers are prone to use the notation.

Q. 2. My Navy type receiving tuner has a primary winding consisting of a single layer of No. 20 enameled wire wound upon a tube  $4\frac{1}{2}$  in. in diameter for a distance of 5 in. The secondary tube is  $3\frac{3}{4}$  in. in diameter, wound for a distance of 5 in. with No. 30 enameled wire. What is the maximum wavelength this tuner will respond to?

A. 2. Lacking the dimensions of the aerial it is difficult to advise; but with one of the usual amateur dimensions, the primary circuit is adjustable to waves of 4500 meters. With a capacity of .0001 microfarads in shunt, the secondary circuit will respond to 2400 meters

A. 5. 4 volts.

Q. 6. What is the voltage of the second battery?

A. 6. 25 to 45 volts.

Q. 7. Is the Audion tube suitable for this?

A. 7. Yes.

Q. 8. Can you give me the voltage of the telephone battery in the RJ5 Audion?

A. 8. 25 to 45 volts.

Q. 9. What type of battery cell is used?

A. 9. A 20-ampere hour storage cell for the filament and 10 tungsten flashlight cells for the telephone battery.

Q. 10. How many turns of edgewise wound copper ribbon  $7\frac{1}{2}$  in. inside diameter,  $8\frac{1}{2}$  in. outside diameter, 1-16 in. in thickness, are required as a helix for a 3-in. spark coil?

A. 10. The helix requires 10 turns of the copper spaced  $\frac{1}{2}$  in. apart. A condenser of .002 microfarads is sufficient. A single plate of glass 14 in. by 14 in. covered with thin foil 12 in. by 12 in., the glass being  $\frac{1}{2}$  in. in thickness will give the required value of capacity.

**Umbrella Antenna; Variometer;  
Loose Coupled Tuner**

E. C. S., Deer Lodge, Montana, writes:

Q. 1. Please state the dimensions for an umbrella aerial to have a natural wavelength of 165 meters. The pole for support of same is to be 55 ft. in height and the antenna proper is to consist of from 12 to 20 wires. The lead-in wire will not be over 15 ft. in length.

A. 1. We know of no formula by which the natural wavelength of an umbrella aerial can be computed exactly but as an approximation we should say that if the ribs of the umbrella are extended to a distance of 20 to 30 ft. from the top of the mast, the natural wavelength will be about the value you require.

Q. 2. Can a rotary variometer be made to tune from 200 to 1500 meters? If so, please state the correct dimensions.

A. 2. We are not quite sure as to the type of apparatus you refer to. Some misunderstanding seems to exist among amateur experimenters regarding the action and the use of a variometer. Ordinarily the term variometer is applied to a variable inductance the value of which may be varied from nearly zero to maximum by means of two concentric inductance coils of fixed value which are connected in series. The inner coil usually rotates on an axis and is constructed so that it can be turned completely around. In one position the magnetic fluxes of the two coils are opposite with an approximately zero value of inductance. In the other position the magnetic fields of the two coils are accumulative and the inductance value is at a maximum. The variometer for amateur purposes may have the following dimensions: The outer coil may be a cardboard tube 6 in. in diameter wound with a single layer of No. 24 S.S.C. wire to a width of 2 in. The inner coil is 5 in. in diameter wound to about 2½ in. with No. 26 S.S.C. wire. The inner and the outer coils are of course connected in series.

Q. 3. In the case of a receiving apparatus where a distant transmitting station can be tuned to by means of inductance alone, will the use of a variable condenser intensify or assist in any manner in securing a higher degree of sensibility?

A. 3. In an instance where the audion is employed as a receiving detector and the inductance is of such value as to permit the receiving apparatus to be tuned to the distant transmitting station, a variable condenser is of little use, but where the secondary winding of a receiving tuner is fitted with a multipoint switch, the variable condenser gives a closeness of adjustment between the taps of the switch which cannot otherwise be obtained. The variable condenser in shunt to the secondary winding of a receiving tuner is only of value under conditions of loose coupling between the primary and secondary circuits.

Q. 4. From the standpoint of long range and efficiency, which is the better, an inductively receiving tuner or an ordinary straight-coupled tuning coil?

A. 4. Practically equal degrees of signal loudness can be obtained with either type, but the inductively coupled tuner is preferred on account of the ease with which the mutual inductance between the primary and secondary windings can be regulated and the sharper tuning which results. Similar effects of course can be obtained in a simple tuning coil by the use of three sliding contacts, but the operation is more complicated.

- - -

**Photographs of Marconi Apparatus  
and Books on Radio Topics**

H. P. B., Chicago, Ill., inquires:

Q. 1. Where may photographs be obtained of Marconi apparatus either on board ship or inland stations?

A. 1. Application for such photographs may be made to Mr. George W. Hayes, superintendent of the factory, the Marconi Wireless Telegraph Company of America, Aldene, N. J., Underwood & Underwood, New York City, also have in stock photographs of wireless telegraph equipment.

Q. 2. Are there any books on the market which cover the quenched spark system of radio telegraphy in detail?

A. 2. No; there is no publication that covers distinctly the quenched spark system in detail, but practically all modern books of wireless telegraphy cover the subject partially. Perhaps Zenneck's "Wireless Telegraphy" gives about as complete a description of the action of the quenched spark discharger as can be obtained.

Q. 3. Kindly tell me in what publication the following subjects are treated in a simple manner and in a way that may be understood by the beginner, viz.: Damping; Logarithmic Decrement; Inductance.

A. 3. No simpler description of the Logarithmic Decrement and the effects of Damping can be obtained than that given in the May, 1916, issue of the POPULAR SCIENCE MONTHLY.

- - -

**Copper-clad Antenna Wire and  
Thickness of Copper**

P. L. D., Grants Pass, Ore., inquires:

Q. 1. Is copper clad wire with a core of iron wire suitable for wireless telegraph purposes?

A. 1. Yes; it has been used on commercial installations for a number of years.

Q. 2. How thick should be the copper coating?

A. 2. A coating of 1-64th of an inch is quite sufficient.

### A Simple Electrical Device for Purifying Water

A DEVICE for purifying water by means of electricity can be made at very little cost by the use of a few elements which are easily obtainable. It may be done by procuring an aluminum tube *A*,  $4\frac{1}{2}$  ins. long, and  $1\frac{1}{2}$  ins. in diameter. It is immaterial about the gage. Also purchase an aluminum rod *B* the same length, of  $\frac{3}{8}$ -in. material. A piece of hard rubber, or fiber, *C*,  $\frac{5}{8}$  in. thick, and  $1\frac{1}{2}$  ins. each way. This is to be turned in a lathe so it will fit into one end of the aluminum tube.

The rubber cork thus provided has a central hole to receive the  $\frac{3}{8}$  aluminum rod, as shown. One of the set-screws *D*, for holding the head *C* and tube *A* together, serves as a means for connecting with one of the terminals *E*, while a screw *F* in the upper end of the rod *B* acts as a binding-post for the other terminal *G*.

The tube *B* should have a few notches, as at *H*, at its lower end. An inch from the upper end are two or more holes *I*, the object being to provide a means for circulating the water when the current is doing the work.

This manner of treating water is known as the direct electrical method; whereas ozonization is the indirect means. Both systems, however, depend on the generation and application of ozone, or nascent oxygen, which attacks the organic matter in water. The result is that such substances are coagulated and precipitated, thus leaving the water pure and wholesome. This system is in every respect superior to filtration. The latter method clarifies, but does not purify.

The article thus constructed is admirably adapted to stand in a glass of water, as shown, for a minute or two,

and then be taken out. The action of the current in passing through the water between the electrodes *A*, *B*, causes a milky appearance, which gradually changes. The solid matter first gathers at the surface of the water, and after giving off the gases contained in the globules, falls to the bottom, leaving a clear liquid.

A wonderful test of the efficiency of this method of purifying may be made by adding a few drops of ink to the water before putting in the device. It will be found that the precipitate will contain all the ink, and that the water will be as clear as before.

The water moves up along the space between the two electrodes, passes out through the holes *I* and down outside of the tube *B*. By means of the circulation thus set up every part of the water is treated and the oxygen bubbles pass through the water, thus attacking the organic matter and eliminating it entirely.

The duplex wires *E*, *G*, should have an electric plug at the other end which may be applied to the ordinary socket. The dimensions given will be correct for a 220-volt circuit. In case of a 110-volt circuit the tube *A* should be  $1\frac{1}{4}$  ins. in diameter, or the rod *B* should be larger, say,  $\frac{1}{2}$  in. or  $\frac{5}{8}$  in. in diameter to give the most efficient service.

There is some difference in the resistance of various waters, which is not sufficient to require a change in the specifications, but in such cases the experimenter will soon learn the correct time required to treat a certain quantity of water, and not allow the device to remain in action too long.

The device will act equally well by plunging it into a pitcher of water, if left there long enough to thoroughly ozonize the whole.

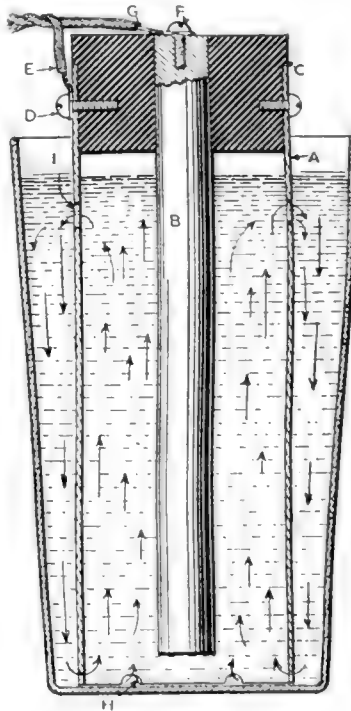

The water moves up along the space between the two electrodes and down outside the tube

Converting a Freight Car Into a Wireless Station

WHEN the United States troops went into Mexico, they were forced to meet a number of unusual conditions. In Vera Cruz, for example, they found new and difficult situations and their ingenuity in overcoming some of these handicaps is interesting.

A train was run twice daily under a flag of truce from Vera Cruz to the interior. This was always accompanied by a small guard. Inasmuch as a treacherous attack upon the cars was likely to occur at any time, it was considered desirable to keep in communication with the train. Since this could not be accomplished in any other way than by wireless, a complete installation was made in one of the passenger coaches. An upright was erected at each end of the car, and aerial wires were strung between cross-arms mounted upon these. The instruments themselves were placed upon the cushioned seats within the car, thus avoiding difficulty from vibration. The ground connection was made through the trucks of the car, and power for the transmitter was supplied by a small hand-power generator. A fixed radio station was also installed at headquarters in Vera Cruz, and messages were exchanged between this plant and that on the train, even

when the latter was in motion.

When the Army landed, the Navy men were relieved of guarding the city and train, and the Signal Corps took over the wireless work. A small gasoline-driven motor-generator was placed on the train, and the satisfactory work was continued until the main railway line was reopened and through trains began

running between Vera Cruz and Mexico City, some months later.

A new Headquarters station was erected on the roof of the Terminal Railway Station, hav-

ing a four-wire umbrella antenna supported from a 40-ft. pole, and maintained constant communication with all the neighboring plants as well as with the ships in the harbor. By use of the network of wireless and buzzer-systems it was possible for Headquarters to learn instantly of conditions at all the outposts.

A narrow gage railway line connected Vera Cruz with the detached post at El Tejar, about nine miles south, and the train wireless equipment was transferred to cars run over this division. No passenger coaches were available, so a framework with a flat-top aerial above it was built upon one of the springless flat-cars. When the

train was still this worked well, but with the cars in motion there was so much vibration that a springboard was arranged to support the apparatus.

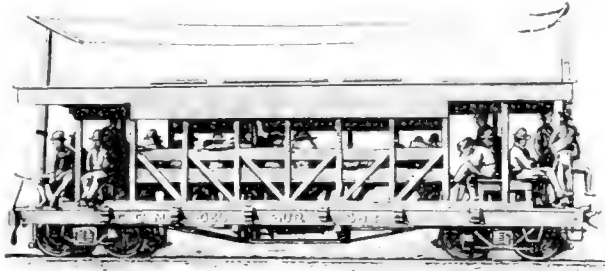

The exterior view of the car with aerial on top



Interior view showing the apparatus in working order

### A Combined Farm Implement Shed and Machine-Shop

THE accompanying drawings show a plan for a farm implement store-room and machine repair-shop. The construction is very simple, being a rectangular building with an ordinary plain gable roof of one-third pitch, all being set on a concrete foundation. The size of the entire building is 72 ft. long by 24 ft. wide, with a 9-ft. studding. This size is sufficient to house an automobile, a tractor and much of the farm machinery, leaving a space 24 ft.

Such a building can be made attractive and substantial if properly located. The cost is not prohibitive. The materials required for the concrete work are 32 barrels of cement, 15 yards of sand and 24 yards of gravel. The framework will require 2,800 ft. of 2-in. dimension lumber, 2,300 ft. of siding, 2,400 feet of lumber and 21,000 cedar shingles.

If the plot is not level excavate the ground the size of the building and thoroughly tamp it down, or place in cinders and tamp them well before

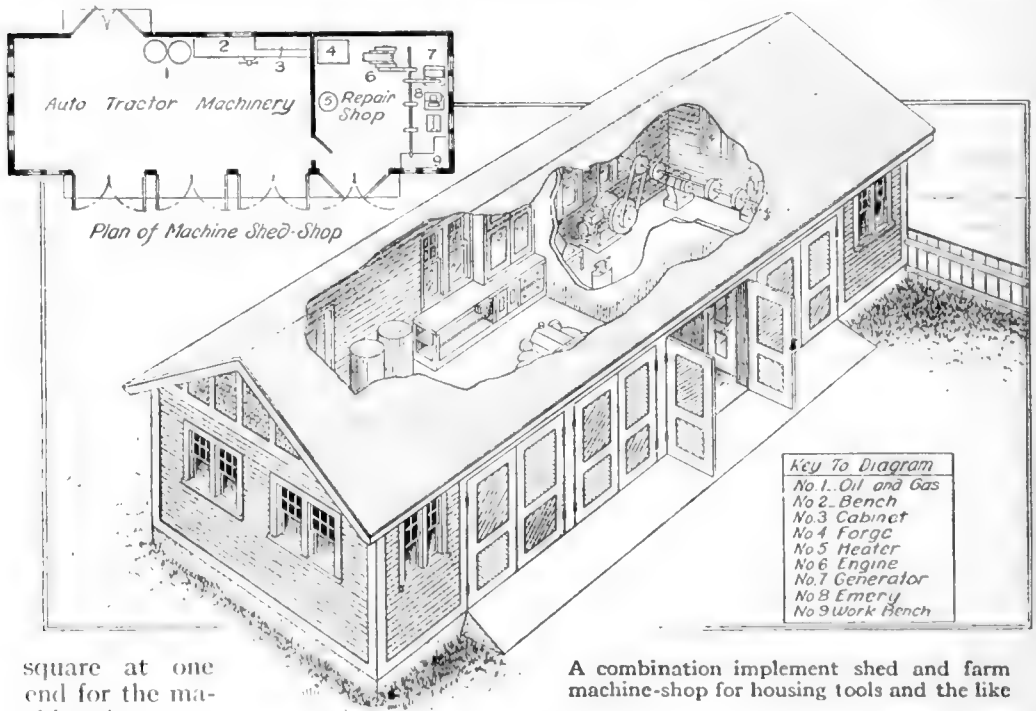

square at one end for the machine-shop.

The shop end of the building is essential; for the intricate machinery of the farm equipment to-day requires better facilities for mending and keeping in order than just a forge and an anvil.

The shop part is large enough to accommodate a gasoline engine, about horsepower, for driving a line-shaft, where power may be used to drive a drill press, lathe or emery wheel, or to house a farm lighting-plant. If a good partition is provided this part of the building can be heated with a small stove at practically no cost.

A combination implement shed and farm machine-shop for housing tools and the like

beginning to put in the concrete mixture. Forms of rough boards may be held in place with stakes on the outside line of the building and the concrete put in the same as for building a sidewalk, making the surface of a neater mixture and troweling it down smooth. The building is raised on this in the usual manner.

The approach to the doorways is also made of concrete and should be a part of the floor. The forms can be built up at the ends sloping so that the surface can be struck off with a straightedge. This is the most economical method.

#### Key To Diagram

- No. 1. Oil and Gas
- No. 2. Bench
- No. 3. Cabinet
- No. 4. Forge
- No. 5. Heater
- No. 6. Engine
- No. 7. Generator
- No. 8. Emery
- No. 9. Work Bench

# To Our Supporters

When Edward Livingston Youmans founded the *Popular Science Monthly* in 1872, he had a very clear purpose in mind. "Science is not the mystery of a class," he put it, "but the common interest of rational human beings." And so he would tell a contributor: "Keep in your mind's eye a person of common intelligence and quite unacquainted with the subject you are seeking to explain."

When I assumed the editorship of the *Popular Science Monthly* a year ago, I made up my mind that we must never lose sight of Youman's ideal. The opportunity was rich. Wireless telegraphy, aeroplanes, automobiles, radium, X-Rays, all were unknown in his day. In a single year more scientific discoveries and important inventions are now made than in a whole decade forty years ago. And then, the technique of printing and illustrating has developed marvelously. There was no half-tone process when the *Popular Science Monthly* was founded, no rapid and effective way of driving home a point by picture.

With this wealth of modern material and with wonderful modern facilities, the *Popular Science Monthly* entered upon a new phase of its career a year ago. In that brief space of time its circulation has more than doubled. Over two hundred thousand copies are now printed. And the circulation is growing by leaps and bounds.

I wish to thank the many thousands of supporters who have made this success possible and, above all, the hundreds of contributors who have helped me to present the facts of current science, engineering and invention interestingly and truthfully.

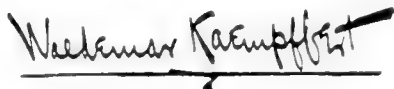
A handwritten signature in black ink, reading "Waelamar Kaempffert". The signature is written in a cursive style with a horizontal line underneath it.

PHILIP  
LYFORD

The football coach, gripping the lever-handle firmly swings the dummy away from the tackler as he rushes at it. The effect is that of an active, dodging, living opponent



# Popular Science Monthly

239 Fourth Ave., New York

Vol. 89  
No. 5

November, 1916

\$1.50  
Annually

## Training the Football Tackler

A tackling dummy which moves as if it were a live player running around the end

FOOTBALL as now played is a well-balanced, interesting game, with emphasis laid more than ever on the physical development of the players. During recent years the game has undergone refining at the hands of experienced sportsmen, with the result that open playing is encouraged in preference to the rough and tumble close formation of other seasons. The demand today is for more speed and better generalship.

Football is so strenuous a game that it may not be played without preliminary training. A thorough mastery of the sport calls for the proper coordination of brains and brawn.

A number of mechanical contrivances have been invented to harden the football recruit during his practicing season. Tackling dummies are perhaps the most numerous. They require tactics which are far removed from the actual operation of bringing a player to the ground when he is running at full speed. Throwing a lifeless figure prostrate is entirely different from tackling a moving figure.

Oliphant of the "Army," the human battering ram, carried from one to four tacklers down the field with him when he was running with the ball. No amount of preliminary practice enabled players to halt his terrific rushes. It is just possible, however, that if a tackling

device such as that illustrated on the opposite page had been used in teaching the players the rudiments of scientific tackling, Oliphant might have met his Nemesis.

John H. Ashton, a Brown University man, has overcome many of the most serious defects in existing tackling devices. His dummy moves exactly as if it were a live player on a quick run around the end. When the player tackles the dummy, it does not immediately fall to the ground, but furnishes a positive resistance to a downward drag, so that the player must use the

same force that he would employ to down an opponent. The dummy hangs by a steel cable from an arm mounted upon a hollow mast. Attached to the mast, at a point where a bracket meets it, is a handle, used to rotate the frame at any desired speed to impart the proper momentum to the dummy. As the player rushes toward the dummy, the coach pulls the handle, causing the dummy to swerve away from the attack. There is a counterweight in the hollow mast.

The dummy hangs by a steel cable from an arm mounted upon a hollow mast. Attached to the mast, at a point where a bracket meets it, is a handle, used to rotate the frame at any desired speed to impart the proper momentum to the dummy. As the player rushes toward the dummy, the coach pulls the handle, causing the dummy to swerve away from the attack. There is a counterweight in the hollow mast.

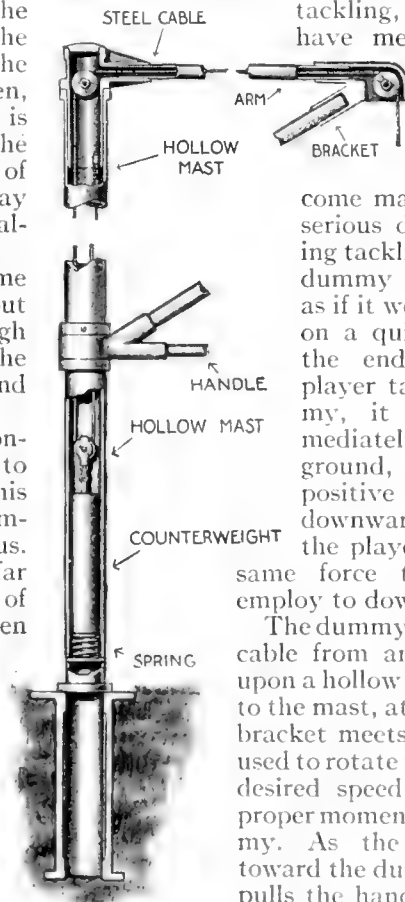

The hollow mast and its various parts

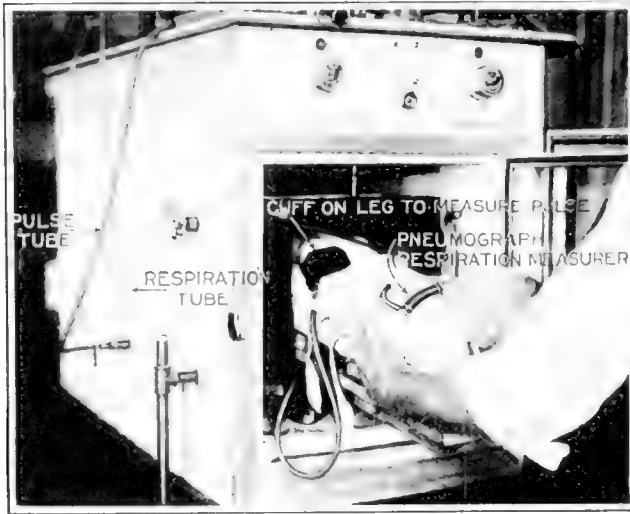

The instruments showed that underweight babies produced more heat units or possessed more horsepower than did fat babies

#### Measuring the Horsepower of That Baby of Yours

**D**R. JOHN R. MURLIN, of Cornell University Medical College, has devised an apparatus which causes a baby to record its own horsepower. Horsepower is used in this sense merely as the expression of a unit of energy. Dr. Murlin devised this apparatus for use in the study of the energy requirement of the new-born child.

A baby unconsciously writes the story of its energy by means of its pulse and its breathing. A small cuff is attached to the left leg of the infant above the knee. From this cuff a tube leads to a glass connection, passing through the wall of the incubator and finally to a T-tube on the top of the incubator. One limb of this tube passes to an air-pump and the other to another T-tube. To the second T-tube a mercury pressure gage (manometer) is connected by one limb and a pressure-bottle to the other. From this bottle a transmission-tube leads to a recording drum. Thus with each pulse the baby makes a record.

Oddly enough, the fattest baby produced the smallest degree of horsepower. While sleeping the babies produced an average of .004 of a horsepower. It was determined that the normal heat production of recently fed, sleeping babies between two months and one year of age is .09 horsepower.

#### A Magnet Made from Two Discarded Cannons

**P**ROBABLY the largest and strongest magnet in the world is at Willett's Point, N. Y. It was made by accident. The commander of the post happened to see two old fifteen-inch Dahlgren guns lying unused side by side on the dock. He conceived of the idea of converting them into a magnet of enormous power by winding submarine cable around them.

The magnet, which stands about ten feet from the ground, is eighteen feet long, and has eight miles of cable around the upper part of the guns. It takes a force of twenty-five thousand pounds to pull off the armature. A crowbar applied to the magnet requires the combined force of four strong men to tear it away.

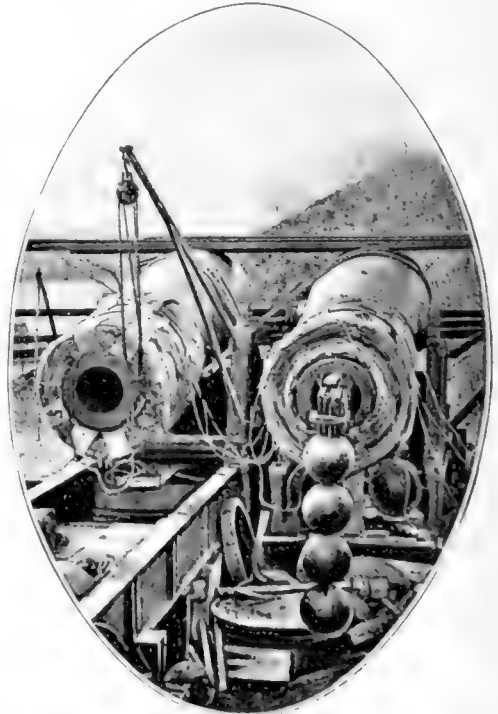

Two 15-inch Civil War cannon converted into an electromagnet which is so powerful that it takes a force of twenty-five thousand pounds to pull off the armature

# A Washstand Light for Garages

Plenty of light is needed in the garage, and so an ingenious, movable box of lights is used



A flood of light may be thrown upon any portion of the body of the automobile without subjecting the bulbs to contact with the spray. The box can be elevated to any height

**T**HE washing of automobiles in garages which is the regular night work of the attendants, is greatly simplified by the use of the novel lighting device shown in the accompanying illustration. It is hung from the ceiling and may be moved up or down alongside the car according to the part being cleaned.

The unit consists of an enclosed tin box with eight electric-light bulbs in sockets in the bottom. On the top of the box are two hooks to which are connected two small ropes running over two pulleys which are suspended from the ceiling.

The ropes then pass to a two-sheave pulley on the side wall near the ceiling and then down to a cleat within the reach of a man on the floor. By letting out or taking in the ropes the box may

be lowered or elevated to any desired height. It is kept just high enough above the parts being cleaned to prevent the water from splashing on the bulbs and breaking them.

The bulbs are further protected from injury by means of a small wire guard on the bottom of the box, as shown. The cable carrying the light current is attached to the wall with considerable slack, so that it will not interfere with the upward or downward movement of the lights.

The box containing the lights may also be laid flat on its side on an improvised stand in order to throw a flood of light underneath the automobile when repairs are to be made or when cleaning or oiling is to be done. Heretofore, individual lights enclosed in wire guards were used. This method was found dangerous.

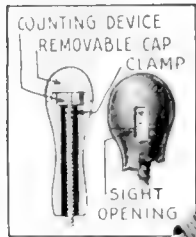

A mechanism in the handle counts the jumps



### Letting the Jumping Rope Record the Jumps

ALL the vocal gymnastics have been taken out of the youthful pastime of jumping rope. No longer will numbers be called as the prodigy next door jumps up to five hundred or more, and the chances are that "Pepper, salt, mustard, cider, vinegar," will be forgotten. Two inventors of New Brunswick, New Jersey, Edward H. Stokes and Raymond E. Grymes, have invented a jumping-rope which will automatically register the number of times it is turned. In other words, children can jump themselves to death without uttering a sound.

In a handle at one end of the jumping-rope is a counting mechanism which registers each turn of the rope. The handle is hollow so that the rope enters it and connects with the counter at the front end. A removable cap makes it possible to adjust the counter. A sight opening is provided in the side of the handle to enable the jumper to note the number of turns.

### Why You Hear Well on a Clear, Frosty Night

SCIENCE says that the loudness of sounds varies inversely as the square of the distance. This is merely another way of saying that if you walk three times as far away from the source of the sound as you were before, its loudness will be not one-third what it was, but one-ninth what it was, for nine is the square of three.

On the other hand, the density of the medium which conveys sound is very important. On a frosty night the air is dense. One consequence of this is that an automobile runs better, because the engine gets larger supplies of oxygen. Another result is that sounds are heard more loudly. However, the report of a gun high up in the mountains is like the sound of an exploded firecracker. In the Colorado Rockies giant boulders are carried along by snowslides. On a warm night the slides make little noise, but on a clear, frosty night the noise is deafening.



As dangerous as it is exciting

### Increasing the Thrills in Ice-Skating

SKILFUL skating on ice is difficult enough with ordinary skates but with stilt-skates, such as those illustrated, it is in a class with dangerous sports. The ice is hard enough when hit from the usual height. How must it feel when stilt-skates skid out from under you?

There are only three people in the United States who have attained proficiency in the art of skating on stilts. C. P. Muldoon, who appears in the illustration, is one of them. His stilts are twenty-four inches high and carry a steel plate at the top and bottom.

There are nine parts to the skating apparatus, adjusted to suit the skater. According to those who have used stilt-skates they are just as safe as ordinary ice-skates, and they give just as much pleasure and comfort. There is no denying the fact that they afford pleasure; but as for comfort—that is for professionals.

**A High-Speed Bit That Bores Without Choking**

**A**n auger-bit has been invented with several novel constructional features. The twist is just the reverse of all other so-called double-twist auger-bits in that the bit is made very thick at the edges and thin in the center. The technical reason for this change is the generally acknowledged weakness of an auger-bit that is caused by its tendency to clog or choke when boring holes more than two or three inches in depth. The twist of an auger-bit is essentially a conveyor. The rubbing of the chip against the wall of the hole being bored causes it to be retarded and it finally packs so tight that the bit refuses to bore.

In the new type of bit the thickened edge which keeps the chip closer to the center of the bit provides ample room for chip passage.



The thread of the bit extends beyond the center of the point

Generally the tubs are so low that they make washing a back-breaking operation. For this reason, probably, stationary tubs in the more modern of our apartment houses are seldom used for washing.

With the advent of an electric washing-machine for stationary tubs, however, it looks as if the family washing might be done at home after all. A new electric washer will help in attaining that end. It is enclosed in a stationary tub and is provided with two motors, one of which is attached to the bottom of the tub. The other, which operates the wringer, is on a special platform which holds a basket, into which the clean clothes fall from the wringer.

As will be seen from the accompanying illustration, a switchboard is built into the tub between the two sets of faucets, so that it is entirely out of the reach of mischievous children.

**Turning the Stationary Tub Into an Electric Washing-Machine**

**T**HE stationary tubs in the kitchens of our apartment houses have not simplified the task of housekeeping.

**Some Weather Bureau Duties We Overlook in Criticising the Weather Prophet**

**W**HY do we have a Weather Bureau? This question is likely to be asked, in more or less querulous tones, whenever the local weather prediction fails, as it often does. The inquirer overlooks the fact that the Weather Bureau has much more important things to foretell than ordinary changes of weather. It predicts with certainty great windstorms, destructive floods, severe freezes and other atmospheric visitations that endanger life and property on a large scale and collects climatic statistics for scientific agriculture.

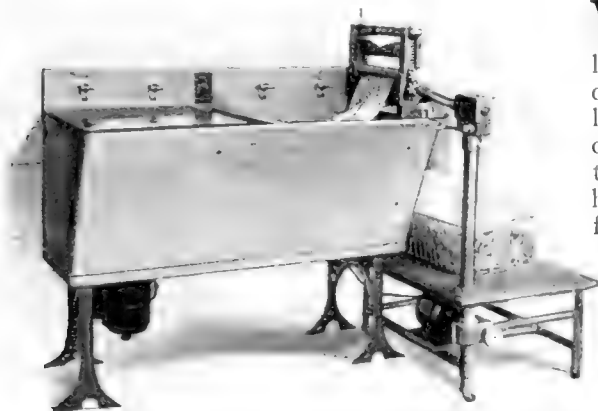

The washer is enclosed in the stationary tub and is provided with two motors and a switchboard

# The Mechanics of Shoplifting

The department store parasite turns inventor and devises some ingenious tools for stealing under the detective's eye



A capacious repository a bag sewed inside a coat

A skirt-bag large enough to hold a baby grand piano—almost

**F**OR sheer cleverness the professional shoplifter deserves the iron cross of thieftodom. He or she (there are just as many men as women in this vocation), must work under the vigilant eyes of detectives. Yet shoplifters ply their trade with seeming indifference, pilfering finery that totals hundreds of thousands of dollars a year.

Although department stores reluctantly admit it, the fact is that shoplifting is as profitable as ever. There are reasons enough. The professional shoplifter has his regular customers for whom he steals. The customer selects the article in the store, the shoplifter steals it, obtains a fair price for it—plus his cleverness, and the deal is closed and forgotten. It is purely a business transaction—cash only, and no questions asked. There is no dickering with a "fence" or second-hand dealer; con-

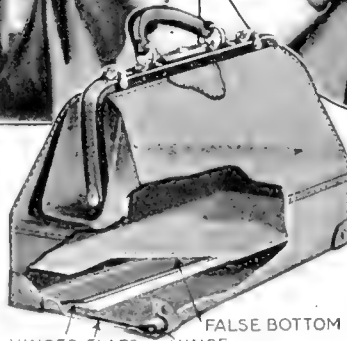

HINGED FLAPS HINGE  
The false bottom travel-bag a Hungarian contrivance

sequently the police are thrown off the usual beaten path.

Unfortunately for our stores the professional shoplifter has found time and opportunity to turn inventor. His tools are

ingenious mechanical contrivances. One of these is the false bottom, hinged-flap traveling bag, recently found in the possession of a Hungarian team—two young men and a woman.

Innocent looking in itself, the bag is a veritable storehouse for purloined articles. The thief places the bag on the counter over the article to be stolen. By leaning carelessly on it enough pressure is exerted to force the article up past the hinged-flaps into the false bottom. If the thief is apprehended the bag is opened and reveals nothing, unless the searcher suspects that there is a false bottom.

When a thief is caught with the

side-flap suitcase, conviction is almost always sure to follow. However, the contrivance is very effective in stealing ribbons, gloves, handkerchiefs and hosiery. The bag is placed on the floor and the articles are simply rolled off the

lished story of her arrest created a furore. Often thieves are caught with two roasting pans wrapped in heavy paper under their arms. Of course, the paper is torn underneath and the articles de-



A shoplifter's sleeve rolled back to reveal the artificial third arm



A bag, sewed in the shoplifter's skirt, filled with all manner of stolen articles

counter on to the flap as the thief calmly looks the salesgirl in the eye. The flap is returned to its position by the foot.

Then there is the subtle third arm used for over a century—an artificial arm, fitted into the sleeve of the coat, which rests quietly on the counter while the real arm inside the coat is busily tucking away stolen stuff. A woman using this means to steal imported laces was arrested in Philadelphia. The pub-



Stealing with a side-flap suitcase. The flap is closed by the foot

posed in the pans. False packages are not uncommon. They consist of paper wrapped around a frame. The interior is large enough to hold six dozen handkerchiefs.

There are muffs, umbrellas, long gloves, blouse-bags, skirt-bags, men's pockets with the bottom at the knee line, shoes with false soles, real babies with conveniently long dresses up which valuable are stored, and many, many others.



# The Constant Warfare Between the Trees and the Rocks



Above: All rocks have cracks which sooner or later the rootlets of some tree search out. The rootlet may die but it leaves a little soil on which another coming later may feed. Then a seed is wafted there and real rock splitting soon begins

Above: The lower part of the trunk and the root of a juniper tree on a mountain side which is slowly but surely splitting a great boulder. The top of the tree has been broken off by the winds but the roots keep up the struggle



An aspen which is forcing apart the rock into which it is growing. The rock could probably trace back a long line of ancestors of this tree each one of which has carried on the warfare relentlessly

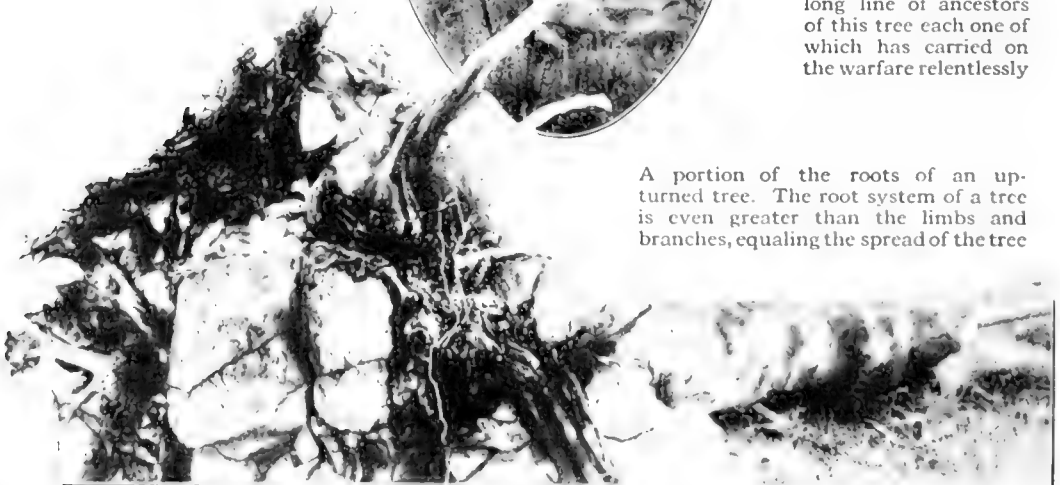

A portion of the roots of an upturned tree. The root system of a tree is even greater than the limbs and branches, equaling the spread of the tree

# A Tree Like the Rock Which Moses Smote with his Rod



Photo Janet M. Cummings

The Traveler's Tree, so called because when its stem is cut a quantity of pure, cold water spurts out, grows throughout the West Indies. Its leaves resemble those of the banana tree

# The Wiles of the North Sea Blockade Runner

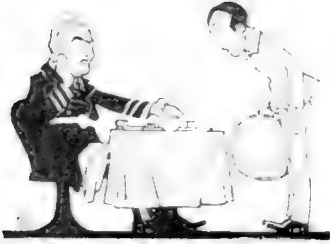

To deceive the British naval officers of the North Sea Blockading Fleet, shippers who used neutral vessels resorted to many ingenious devices. Thus, "rubber honey" was sent in honeycombs filled with a curious mixture

Rear Admiral Sir Dudley de Chair, Commander of the Tenth Cruiser (Blockade) Squadron in the North Sea, states that "whenever a ship is discovered to be carrying contraband, an officer and an armed guard of five men are put aboard to conduct the blockade runner into our nearest port, where examination usually takes from two to five days according to the disposition of the cargo and the consequent difficulty of removing it. The weekly average of ships passing eastward through our patrols is fifty; in summer time, about eight per cent of these are sailing vessels. . . . The British customs officers did not slide easily into new grooves. Accustomed for years to board a ship and inquire merely for dutiable wines or spirits, they were perhaps too easily satisfied. . . ."



According to Rear Admiral de Chair, rubber was sometimes smuggled through in the form of onions. "These were discovered when one of our officers dropped one on the deck; the onion bounced up ten feet into the air"

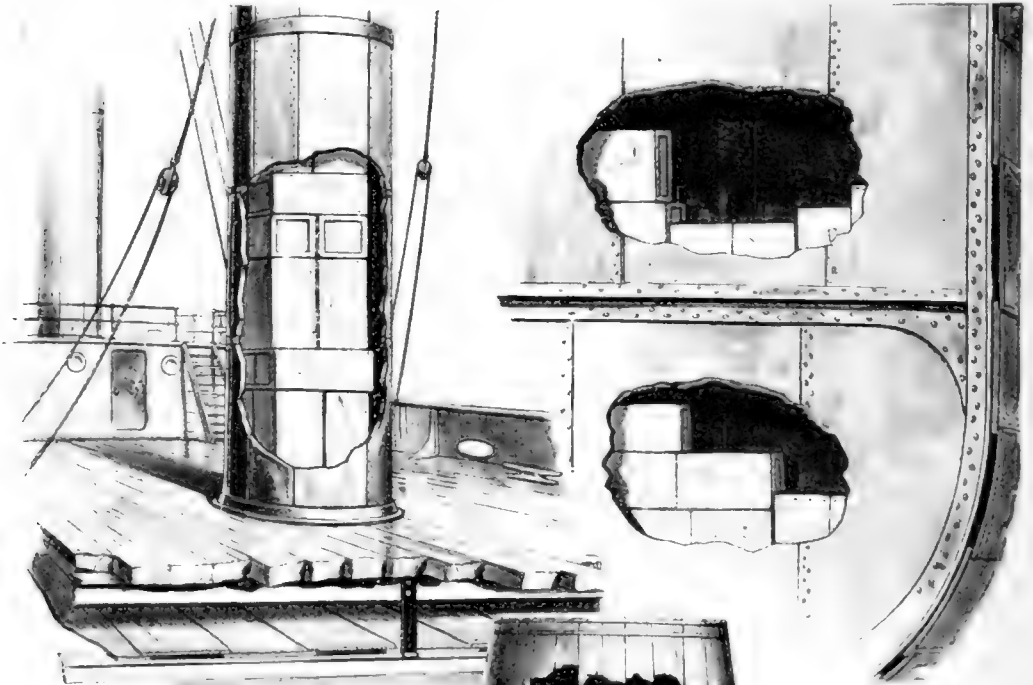

Contraband concealed in the hollow masts of neutral vessels. Below: Rubber hidden in coffee sacks

Cases of guns, rifles, and other firearms or ammunition were stowed away in double bottoms, decks and bulkheads, as shown above. To the left is illustrated the method of concealing cotton in the center of barrels of flour

# Exercising Machines for Wounded Soldiers

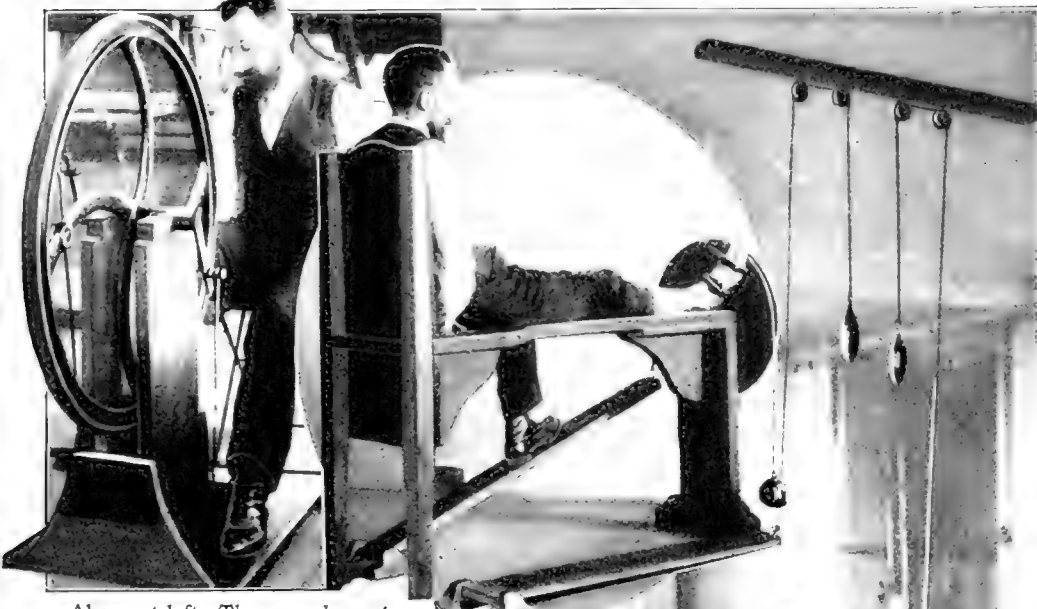

Above at left: The convalescent sits before an iron wheel to which the wounded leg is strapped. He pedals with his sound foot

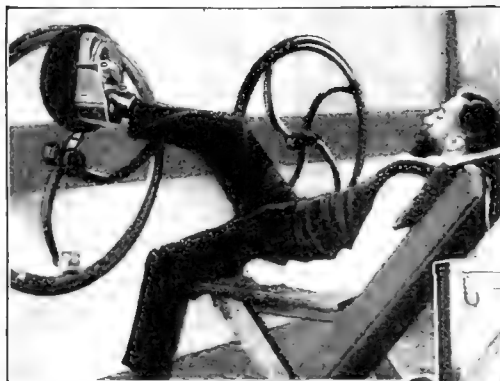

An uncomfortable position? Yes, but better this for a little while every day than a hip that won't work. Stiffness resulting from hip wounds is stubborn but it will yield to this treatment. As the wheel rotates, the foot describes a circle, moving only a few inches at a time at first



Above: Limbering up stiffened wrists by sitting in a chair and pedaling. The wrists are fastened to hinged hand-boards from which weighted cords extend to pulleys attached to the ceiling. From the underside of the hand-board are bars which connect with a pedal below

At right: Hand wounds, where fingers will not straighten out, are treated by a machine operated by pedal, weight and pulley. The hand is strapped to a shelf and the fingers to a sliding board which gently draws them out as the patient pedals

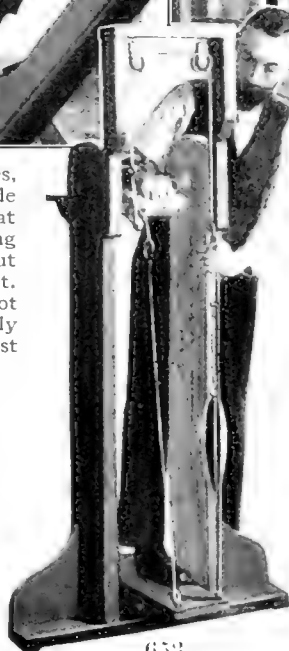

In oval at top: Exercising leg muscles from the ankle to the hip. The foot is strapped to a wooden disk which is revolved by pedaling with the sound leg. Note the cord running over the rim of the disk, and the weight which is attached to the pedal

## A Fish That Builds a Nest Like a Bird



The Stickleback is one of the most interesting members of the finny tribe. It constructs a home for its prospective mate and then mounts guard over it until the mate comes along. The home is built from sea-weed, twigs and aquatic plants which are ingeniously woven together. There are two entrances to the home, which are never left unguarded by the master of the house until the lady of his choice signifies her willingness to enter

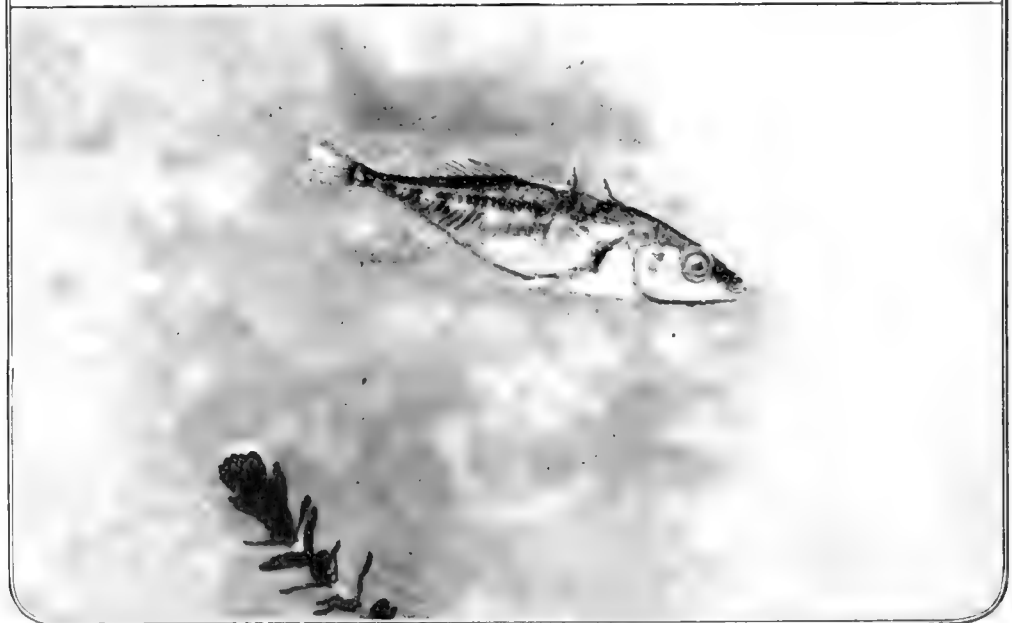

# The Great Hoodoo Temple

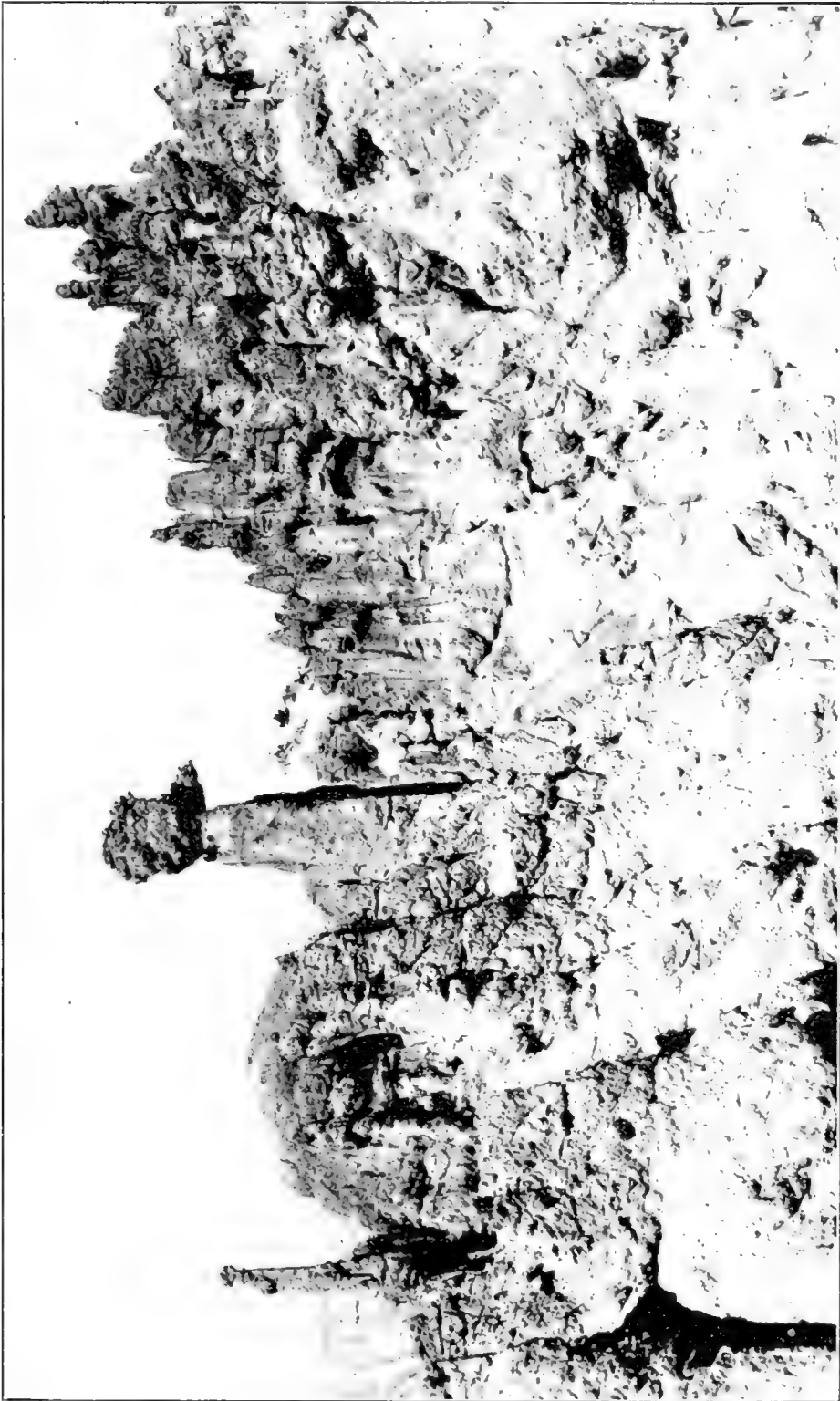

In the Hoodoo Basin of Western Wyoming are curious formations which resemble Punch and Judy heads, grim savages, simpering of maids, monkeys, rabbits, birds and animals in every grotesque and exaggerated shape imaginable, and in every possible position. There are fifty different shapes of heads; over forty different animal and human faces have been counted, and inspiration for innumerable artists may be found there. The rock out of which the hoodoos have been carved by Dame Nature is what is known as volcanic breccia



## Where Germany Gets Her Basalt Paving Blocks



Although basalt wears away rapidly and becomes slippery in wet weather, yet a German company has found it practicable to quarry it in large quantities for paving blocks. The material is quarried in long strips, following the natural lines of its formation, the peculiar construction of which is shown in the photograph below, taken at the quarries at Wilscheidberg. A good workman can make about six hundred blocks in a day





## Introducing Our First Anti-Aircraft Gun



Photo Central News

Mounted on a special platform forty feet high on the battleship Texas is a three-inch naval gun adjusted so that a high angle of elevation can be attained. It is said to be the forerunner of a new type of anti-aircraft gun with which those most interested in our naval and military "preparedness" will adorn the first-line battleships of the future

# The Indian's Conception of Angels and Devils

Below: Two totem poles which formerly marked the headquarters of tribes in Old Mangel, Alaska. To the Indians these designated a religious as well as a clannish bond

At left: A wooden mask carved and painted in the elaborate style dear to the heart of the Iroquois Indians and used by a false-face society



A typical ceremonial mask of the Iroquois. These masks, which seem only hideous, have a tribal significance

The mask on the right would doubtless frighten away any kind of a demon. It was worn by the medicine man



On the left: Another ceremonial mask less typically Indian but evidently meant to depict his enemy-friend, the white man



The Indians were especially fond of animal masks. To them they symbolized the kinship of man to his dumb neighbors



# Some Curious Clocks of Paris



Above: The dial is a soup plate; the numerals are oyster shells; and the hands are a knife and a fork



To the right: The strange clock of a lead-pencil maker. The hands and the numerals are formed of huge lead-pencils

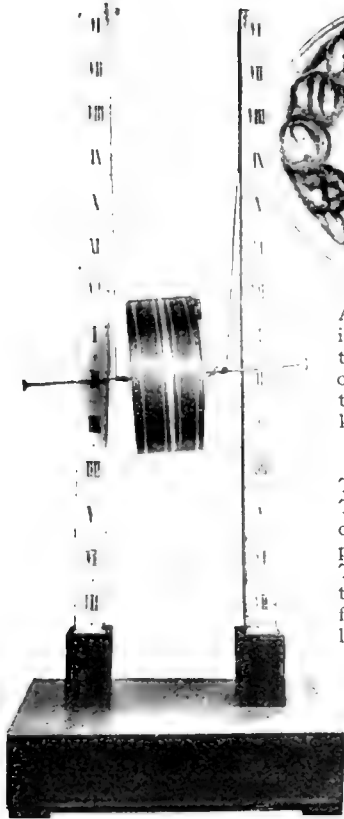

A water-clock which works on the principle of the ancient Greek time-pieces

A clock surrounded by human teeth and resting on human skulls



The clock below, in a Parisian shop window, is made of rosewood and ebony and is composed of two thousand pieces

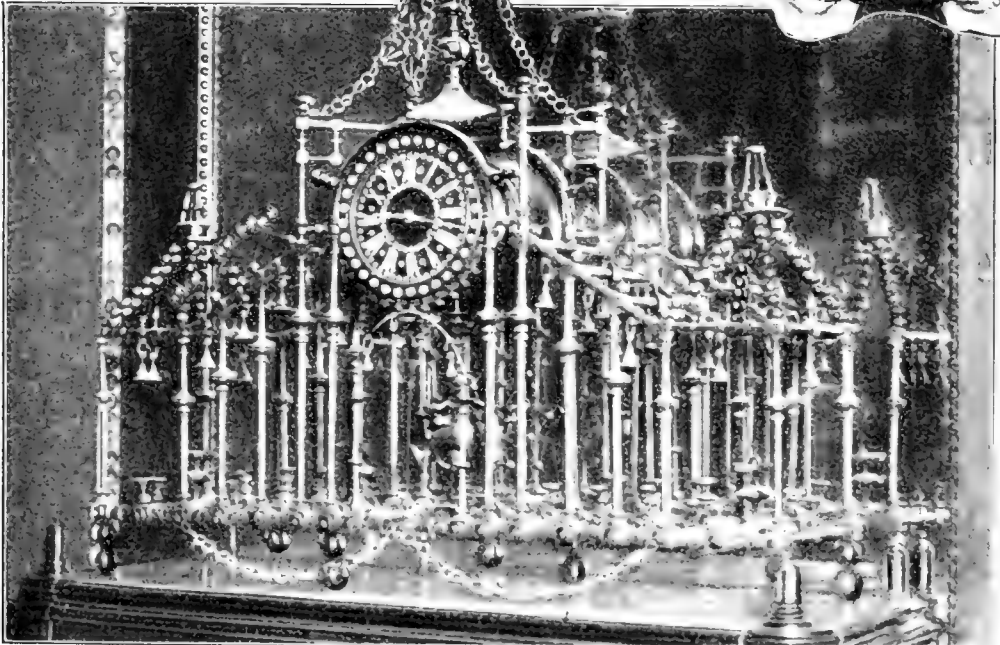

## A Great Collapsible Field-Periscope

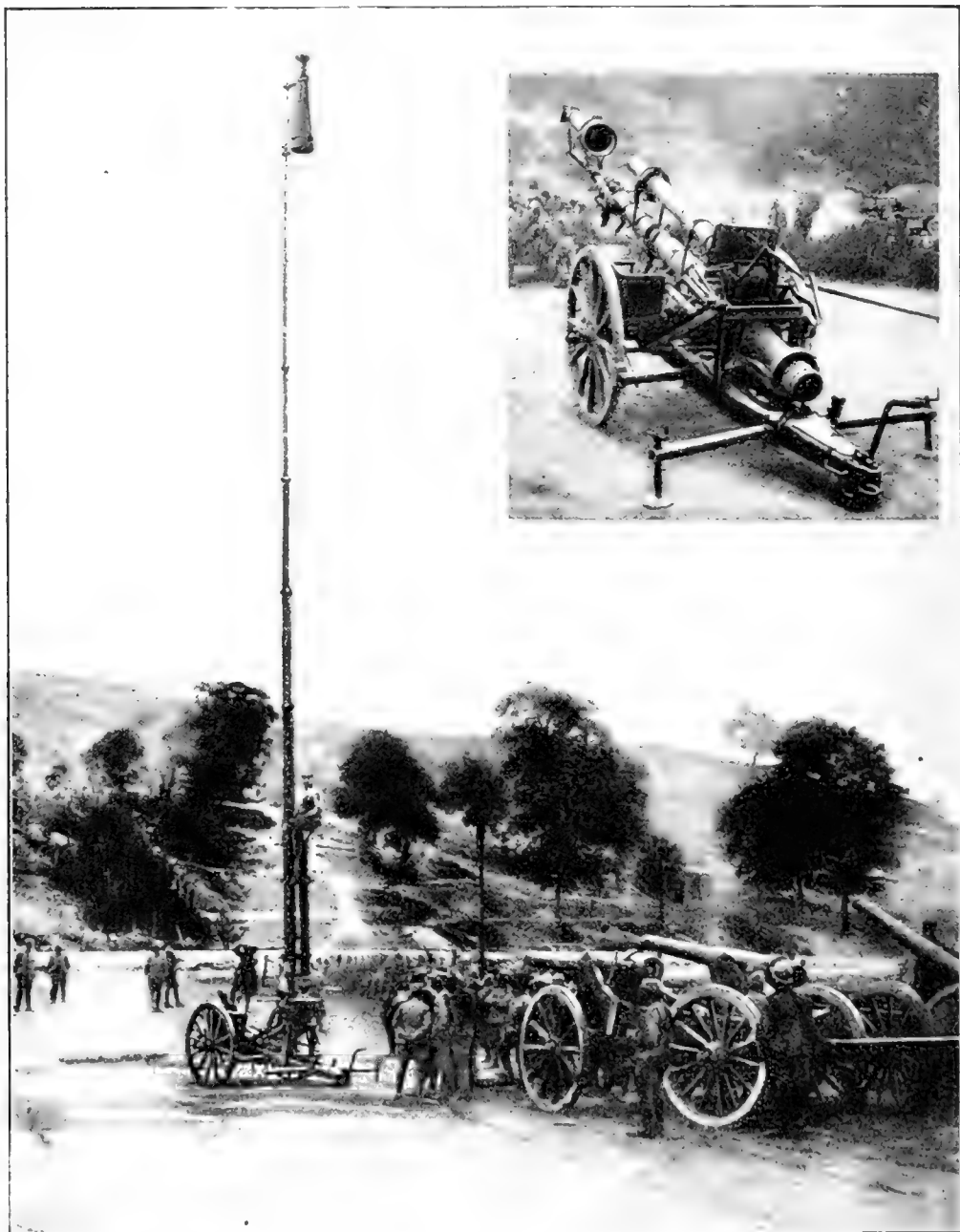

A giant German field-periscope captured by the French during the earlier battles on the Somme. It was constructed by Zeiss, of Jena. The illustration shows it elevated to a height of fifty feet, the carriage supporting the collapsible tube at that height without any props or other assistance. However, with the aid of stays and struts, the periscope can be extended to eighty-five feet, its greatest height. The insert shows the instrument packed for transporting

# Watching a Battle Through a Super-Periscope

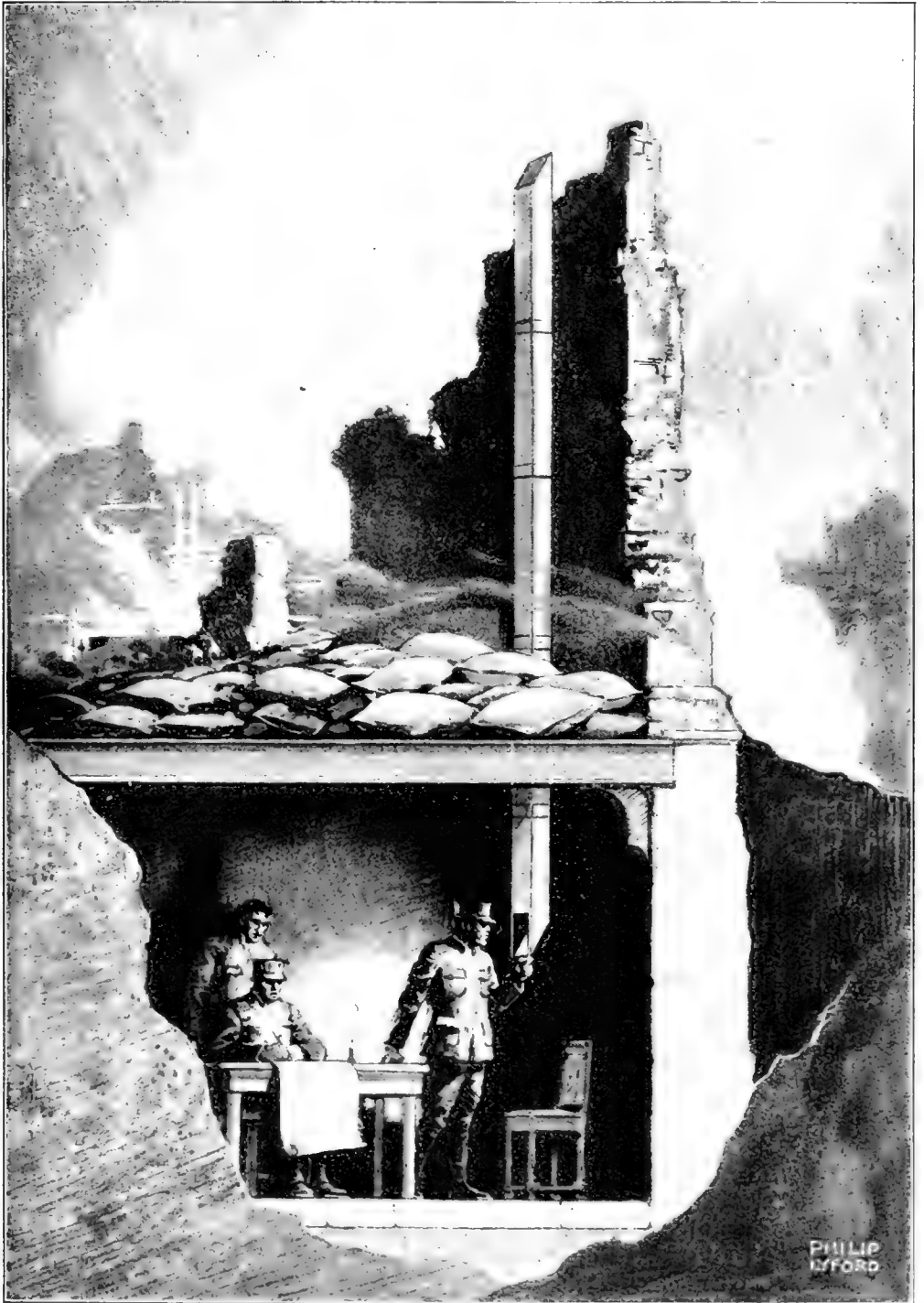

Secreted in their headquarters in the wine cellar of a demolished chateau, the officers are able to watch the battle raging outside with the aid of an immense periscope supported in its place by a wall of masonry. The roof of the cellar is covered with bomb proof pads

# Supplying the Market with Ducks From



Above: A duck farm where 124,000 ducks are raised for the market each year. About seven thousand ducks are hatched each week. The photograph shows the ducks drinking from a trough. Water is supplied from the pipe running above



Below: Taking the temperature of the eggs in the incubator. About 2,200 ducks are kept in the nest pens. The eggs are gathered from these pens at the rate of 1,800 a day and put in the incubator

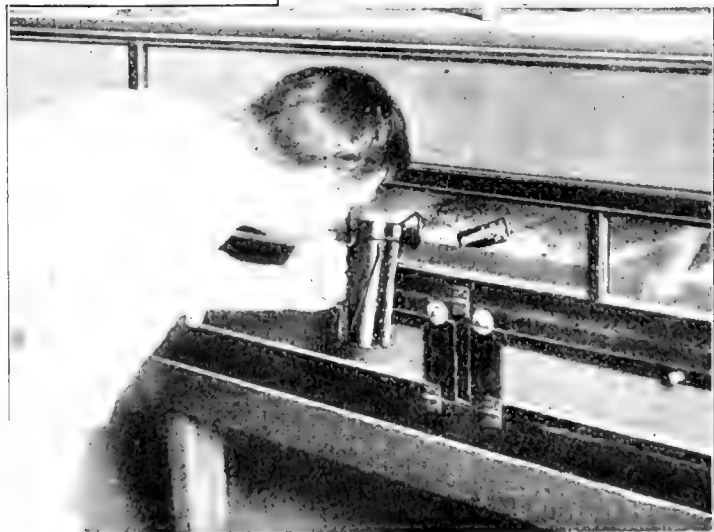

Above: The farm upon which the ducks are raised is traversed by a creek which is divided into pens with sloping banks of sand upon which the feeding troughs are placed. The brooding season is not continuous. The incubators turn out their hatchlings from early in March until early in July. Marketing of the six-months-old and year old birds begins in April and lasts until about November. The season for the younger ducklings is considerably shorter



# The Largest Duck Farm in the World



Above: A huge flock of full-grown ducks, ready for the market. The ducks are kept until they are about eleven weeks old, when they are killed, picked, and dressed for city consumers

Below: Food is carried to the numerous pens in cars which run on a narrow elevated railway. Twenty tons of feed are shoveled out in a day. The feed consists of corn, oats and other grain and green food





# Let a Blast of Air Do It

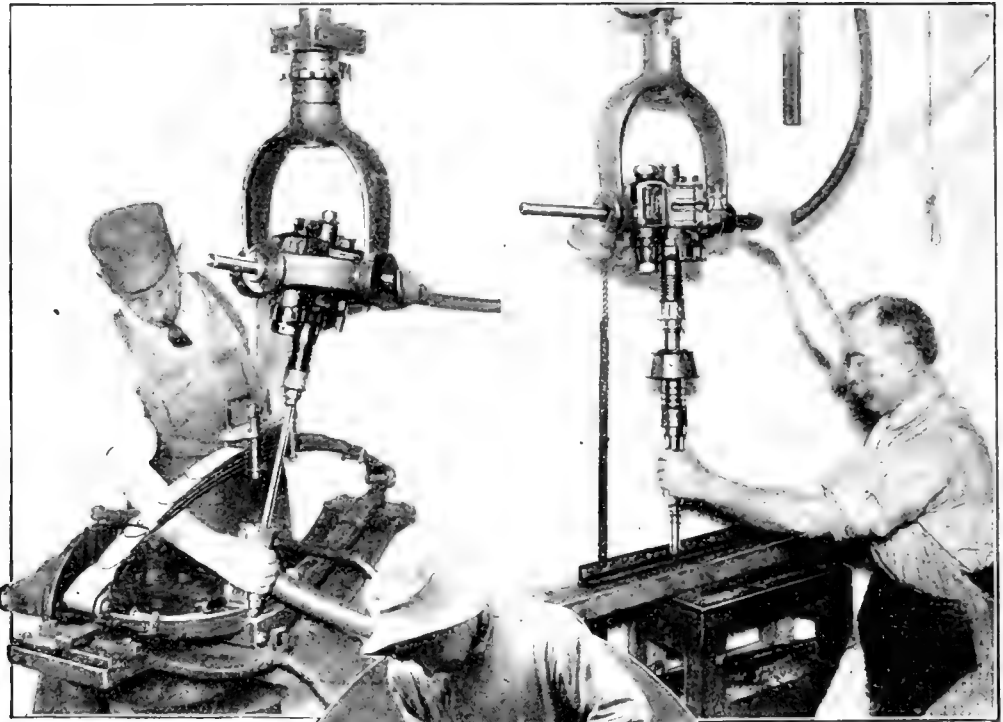

Driving home the spring-clip nuts on an automobile front axle by compressed air. This air-driven wrench saves fifty-six per cent of the time required in using the hand wrench

In this operation a saving of seventy-five per cent in time is effected as compared with the hand-operated drill



At left: A hand hammer drill for use in restricted quarters. It weighs about fifty pounds and requires no mounting or extra help



Below: A rock drill, gasoline - operated. The air is not permitted to escape but is used over and over again

# Air Is Stronger Than Human Arms

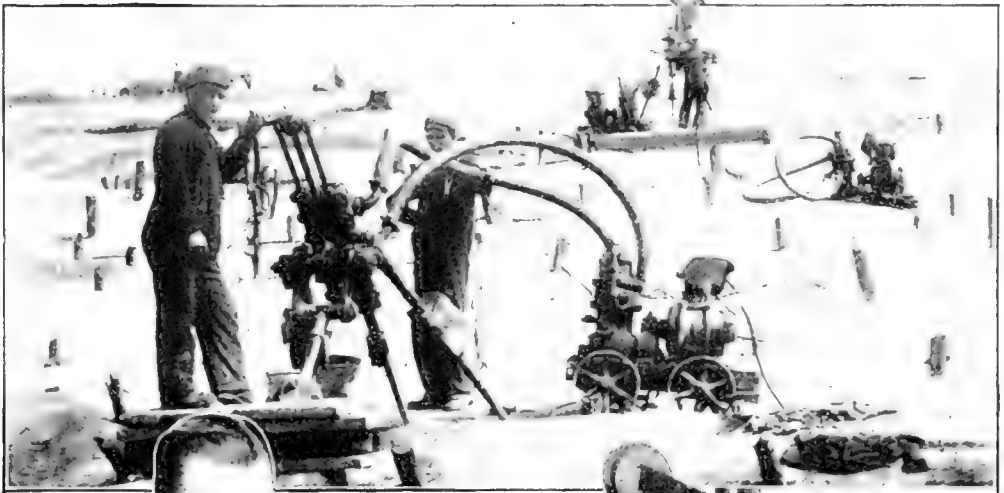

The little truck carries a gasoline engine which operates the air-pump

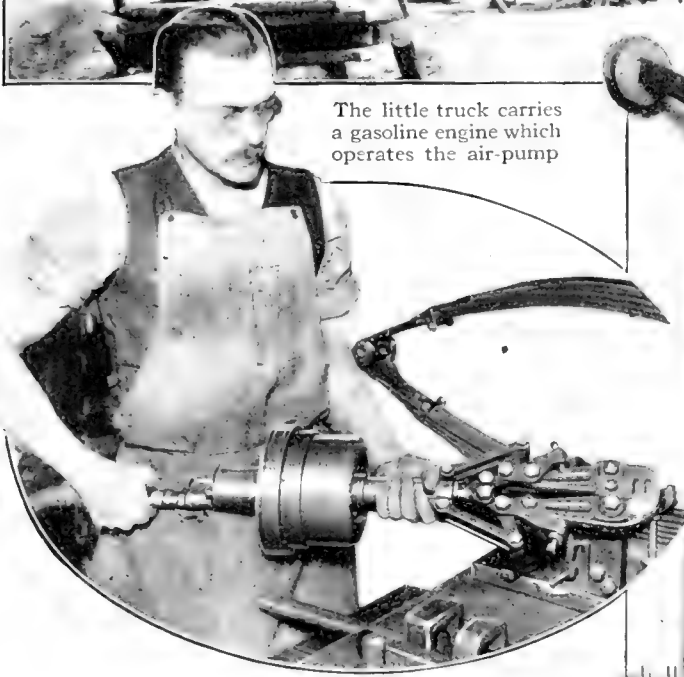

Above: In a Syracuse automobile factory bolts are clipped with this pneumatic tool, with the result that a saving in time of fifty-six per cent is effected. In addition to this, the jaws last twice as long as formerly

Screwing automobile studs and nuts in place with a compressed-air tool instead of by hand, thus saving seventy-one per cent of the time required for hand work. A counterbalance holds up the motor and tool

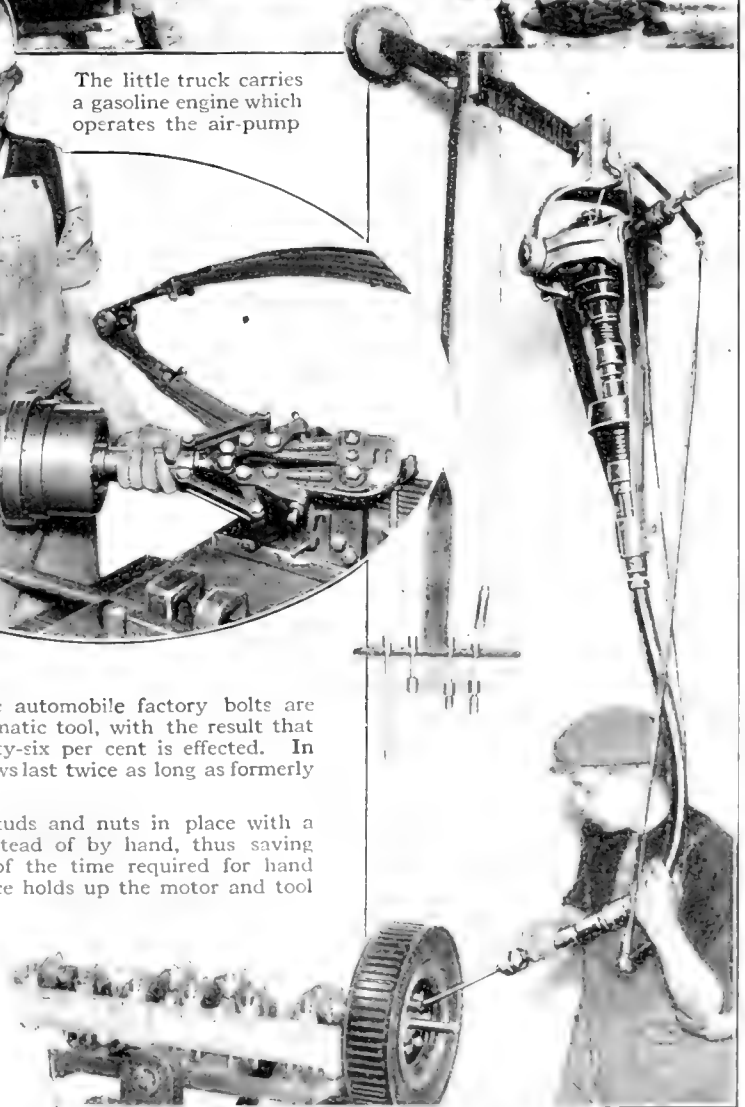

# Dummies That Dance and Play

Wonderful mechanical musicians that  
smoke, bow, wink and pirouette

TWO hundred years ago, before the days of the steam engine and of the factory, the inventive ingenuity of a mechanic, who was bubbling over with ideas, expressed itself in the making of huge automatons—artificial human beings crammed with clockwork and capable of executing with astonishing fidelity acts which seemed to require the control of a brain. There were automatons that danced minuets, automatons that could write stilted phrases in praise of a reigning monarch far more clearly and correctly than most courtiers, and automatons that even went through the motions of playing a game of chess. They were mechanical curiosities—nothing more.

But it must not be supposed that the art of making mechanical dummies is dead. Indeed, it flourishes more richly than ever, simply because it has been

put upon a commercial basis. Only once in his lifetime would an eighteenth century mechanic produce a dancing or letter-writing figure; it was years before he completed his labors. But with the aid of modern factory machinery, automatons are turned out as easily and as rapidly as automobiles. Who wants them? The Coney Islands and the Earl Courts of the world. Somehow the huge, automatic musical orchestras, to the accompaniment of which one eats popcorn and marvels at the tattooed man, are far too tame for the sensation-loving showmen who enliven popular seaside resorts. The orchestras lack the human touch. And so, the machinery that grinds out the latest dance or the

latest song must be adorned with mechanical figures—figures clothed with garish care and very life-like in their stiff, mechanical way. They beat drums, dance, and juggle; indeed they behave very intelligently and correctly.

Triboulet of Paris, is the man who invents many of the more ingenious dummies. That he is exceptionally ingenious follows from the very nature of his creations. He must be something

of an artist, too; for he devises not only the machinery by means of which figures of wood and metal cut capers, but creates a wholesetting like any stage manager.

First of all, a scene is planned. Then a model of that scene with all the figures in it is made in plaster or in wax, and a cast taken. If this piece of sculpture turns out satisfactorily, working drawings are made of heads, arms, legs and the like for the guid-



Painting the faces of the mechanical musicians in Triboulet's shop

ance of shop mechanics.

The animating mechanism of these huge dolls is complicated enough, as our illustrations prove. The clown who grinds the organ, the pyramid of tumblers, the monkey who plays the piano with astonishing skill, are all operated by spring motors and are wound up like any clock. The machinery within the dummies is operatively connected with the music-producing mechanism. By means of starwheels (little copper plates, regular or irregular in form) levers are thrown which operate subsidiary mechanism for the purpose of making a dummy smoke a pipe, whistle, wink mischievously, bow, and perform a dozen ordinary actions.

# Acrobatic and Dancing Dummies



The clown musical director who grinds the organ is a masterpiece of ingenuity

Below: The automatic acrobats, the piano-playing monkey, and the pirouetting clown

Above: Assembling the intricate mechanism which animates the organ-grinding clown

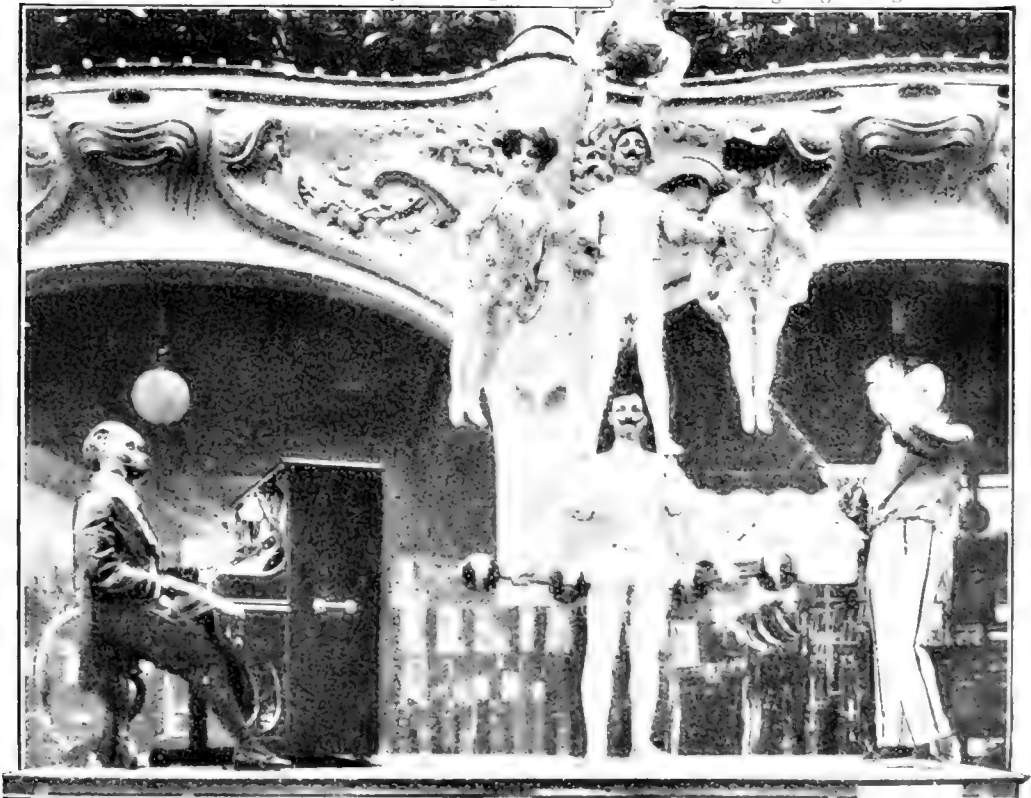



A map of West Virginia made on muslin sheeting. The cities and large towns are designated by tiny electric lights

### Making a Huge Electrical Map of West Virginia

AT a recent gathering of telephone men in Wheeling, West Virginia, a map of the state, ten feet by twelve feet, was made at short notice by A. J. Schulz, of Baltimore. It was hung in the banquet hall and as telephone connection was made with a particular city a little electric light representing that city would appear at the proper place on the map. It was a practical demonstration of how the telephone lines bind together the parts of the state, regardless of mountains, rivers and other barriers.

In its completed form the map was seven times larger than the one from which it was made. Tiny electric lights represented the cities and large towns. A switch was installed behind the map and an operator flashed in the different cities as they were called.

### Collecting Money for Belgians by a Sidewalk Chute

IN order to increase the Belgian Relief Fund, the Boston Headquarters have invented a novel scheme to secure money

from the busy throng which pass the headquarters day and night.

A steel tube four inches in diameter with a funnel-shaped top has been inserted in the sidewalk in front of the building. It is painted with the colors of Belgium, black, yellow and red, and over it is the inscription: "Money Dropped Here Goes Direct to Belgium."

The chute runs directly into the basement and into an iron box from which the money is collected and then forwarded abroad.



A coin dropped in the tube fell in an iron box in the basement, from which point it went straight to Belgium a few days later

Just How You Wear Out  
Your Clothes

WE speak, and speak correctly, of "wearing a suit of clothes" when we have in mind only the use of the clothes; but the garments are literally worn away. We might also speak of "wearing" bed-clothes, because the fibers of the bed linen are worn away in much the same manner as a carpenter wears away the surface of wood when he sand-papers it. Draughts and other air currents waft these fibers to and fro until they collect in small clusters of "fluff." The "bits and cantles" that have begun to attract others to them gather more and more, until a large proportion of the aerial flotsam has been transformed into what the housekeeper calls "little rolls of dust" that she finds under the bed and in the corners. These are fibers that friction has removed from the bed linen and from one's clothing.

Whenever cloth is handled, some fibers are rubbed off and in time become visible and objectionable. The formation of this fluff is not unlike the growth of snowballs that boys roll.

Under the microscope, especially with reflected light, these balls of fluff are wonderfully beautiful, gleaming with a brilliancy that cannot be captured by a photograph.

A New Check Protector No Bigger Than  
a Pocket Match-Safe

A NEW check protector has just been invented by an Oakland, California, man. It is so small and compact that it resembles a pocket cigar-lighter and can be carried in a vest pocket as easily as a match-safe.

It consists of a metal holder, at one

end of which is inserted a round steel die, containing hatched lines. This steel die revolves and its surface comes in contact with an ink pad placed inside the holder. The check to be protected is placed upon a small corrugated aluminum board, furnished for the purpose, and then the hatched wheel of the protector is brought into position on the surface of the check, over the written amount. With a slight pressure the wheel is slowly revolved across the face of the check.

The revolving wheel both prints and perforates the paper, following the grooves of the aluminum sheet underneath. The result is a series of printed, and perforated hatched lines, in a faint-

colored ink, which does not interfere with the legibility of the writing but does prevent any erasures or changes.

The chief advantage of the new protector is its size.

A small, compact instrument for preventing the erasure of signatures on checks

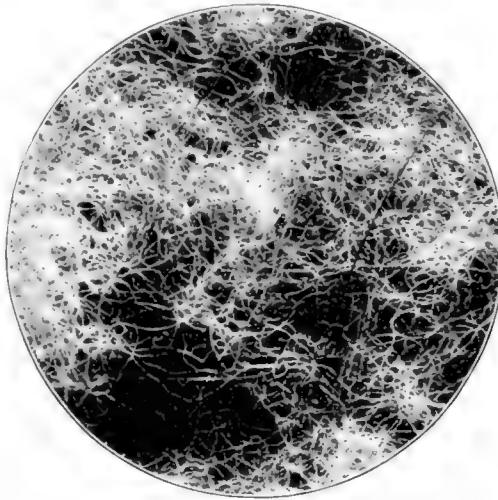

Small clusters of "fluff" blown into what the housekeeper calls rolls of dust



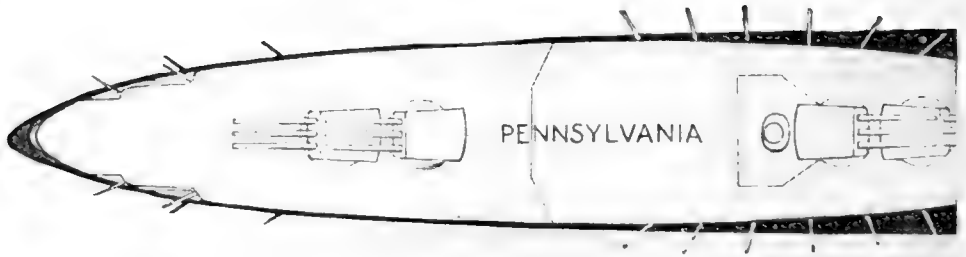

"Is it not fair to assume, nay, is it not certain, that if battleship displacement has increased from ten thousand tons in 1896 to thirty-two thousand tons in 1916, that it will continue to do so until the limit has been reached? Why not go the limit at once? By so doing we scrap the battleships of every navy in the world. . . ."

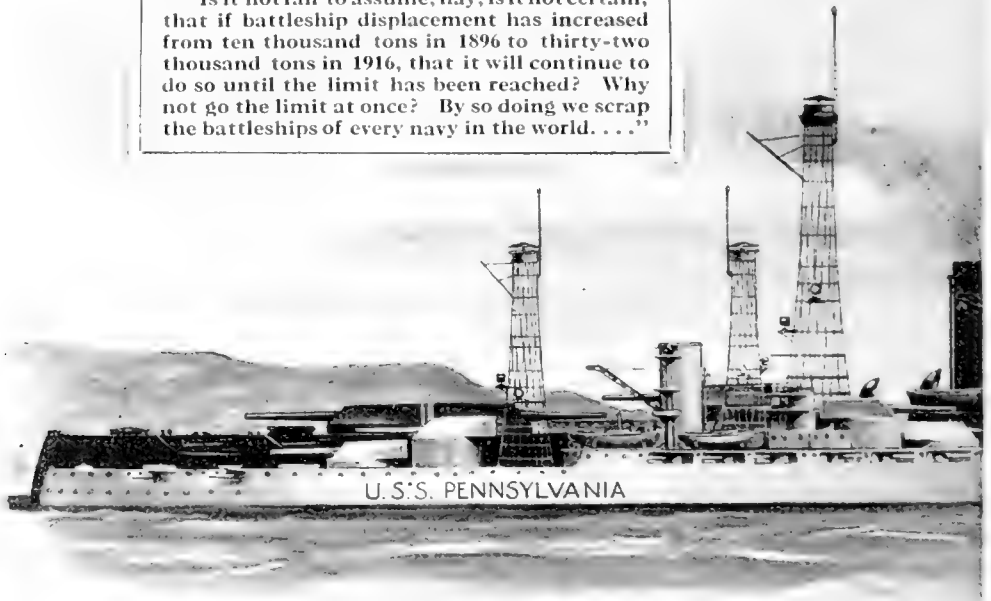

Moffett's ship, shown behind the Pennsylvania and Oregon, is about as long as both vessels.

## The Thousand-Foot Battleship

Commander Moffett's daring plan to beat the world

**H**ITTING a target at ten miles with fifteen-inch guns seems so easy a task in view of the naval battles fought off the Dogger Bank and Jutland that Admiral Sir Cyprian Bridge of the British Navy, maintains that it is inadvisable to build warships bigger than those now in commission. Commander William Adger Moffett of our own Navy, takes direct issue with him, arguing that the whole tendency in warship construction from the days of the sailing frigate to the modern super-dreadnought has been toward the large ship with large

guns. He boldly advocates a vessel more than twice as large as any battleship hitherto constructed—a veritable Titan of the seas.

In an article published in "Sea Power," Commander Moffett points out that only the size of the locks of the Panama Canal limits the size of battleships. That limit applies to the warships of the entire world as well; for no power would sacrifice the advantage of being able to send its fleet through the Canal. Since the Panama Canal locks will receive vessels of one thousand feet length and



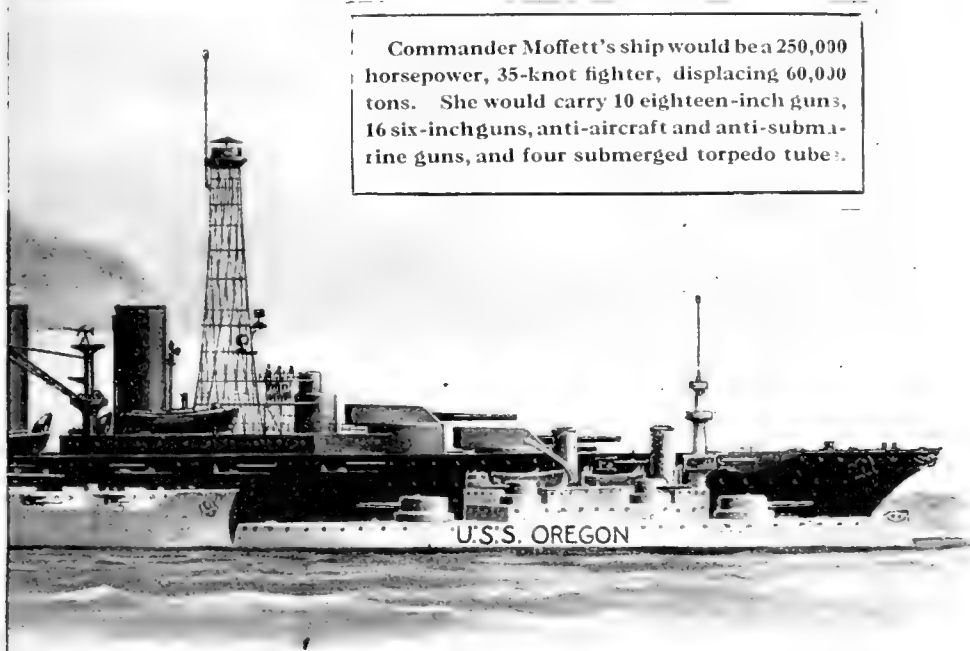
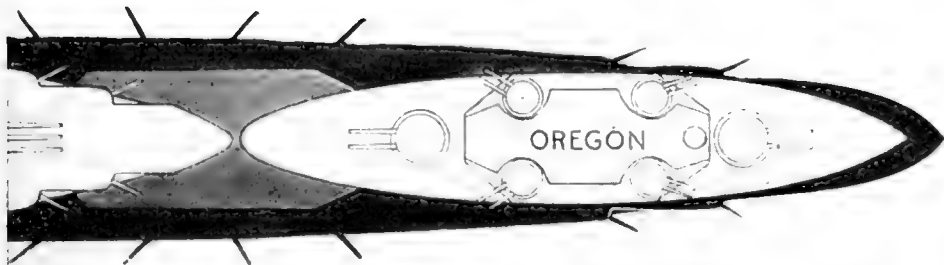

Commander Moffett's ship would be a 250,000 horsepower, 35-knot fighter, displacing 60,000 tons. She would carry 10 eighteen-inch guns, 16 six-inch guns, anti-aircraft and anti-submarine guns, and four submerged torpedo tubes.

She could carry the Pennsylvania and Oregon on her decks, as illustrated in the top plans

one hundred and ten feet beam, the maximum length and beam of the future warship are fixed. "Go the limit at once," urges Commander Moffett, "while we have the opportunity to do it, ahead of all our rivals, and go the limit at the same time in everything; that is to say, in speed, caliber of guns, endurance, fuel, ammunition, etc."

*Puts Limit at 60,000 Tons*

Commander Moffett points out that the growth of the United States battleship from the Oregon type to the new Pennsylvania has been accomplished in less than twenty years, and submits in addition the specifications of his proposed sea giant, the Limit, in the following comparative table:

Battleship	Date	Length	Arm'm't.	Ton'ge
Oregon . . . . .	1896	358 ft.	4 13-in.	10,288
So. Carolina . . . . .	1909	450 ft.	8 12-in.	16,000
Delaware . . . . .	1910	510 ft.	10 12-in.	20,000
Pennsylvania . . . . .	1915	600 ft.	12 14-in.	31,400
Limit . . . . .	1917	995 ft.	15 18-in.	60,000

**To quote Commander Moffett:**

"Other navies would have to follow our example, and build ships like ours or give up the competition. We could stand the cost better than any other nation. It is, therefore, an advantage to us to make navies cost as much as possible. We have more money than any other nation and will have more, comparatively, at the close of the war, when most of them will be bankrupt.

"In this way we will scrap England's navy, as well as all others. In no other way can we hope to overtake Great Britain.

"Build the limit in displacement, in speed in caliber of guns, with proper proportion of fuel and ammunition, endurance, etc., and we will have, indeed, the first real superdreadnought."

### Strenuous Search for Durable Roads in a St. Louis Park

TO the average motorist there are only two kinds of roads, good roads and bad roads. To the road engineer, roads are divisible according



From the dial which the engineer is examining the durability of the roadway is determined

to materials, such as asphalt, brick, etc.

An interesting case came to light recently when the road engineers of St. Louis began discussing stresses, temperature coefficients and other highly technical things in connection with the roadbed of a St. Louis Park. Then an effort was made to find a pavement which would maintain its smoothness regardless of weight and speed of vehicles. The roadway was divided into small sections and concrete applied in various mixtures. Then the roadbed was tried out. The motorist looked upon it as an excellent stretch for a spurt; the engineer looked upon it with an instrument almost as delicate as a microscope.

In the photograph the gage used by the engineers is shown with a solid bar of steel laid parallel to it for purposes of accuracy in measurement.

### Charging the Weak Magnetos of Automobiles

THE magneto on your Ford can be effectively rejuvenated by means of a magnet-charger specially designed for use where a 110-volt direct current line is not available. When your car fails to start easily and you have to change from high to low speed frequently, you may be sure the magneto has become weak.

When someone tells you that he cannot hear your voice in the telephone, it is because the receiver magnet is weak. Party lines are especially liable to suffer from weak generator magnets.

The magnet-charger can be operated from an ordinary six-volt storage-battery, or from a storage-battery charging outfit, such as that used in garages to charge starting or lighting batteries. Three or four applications of the current on each end of the magnet up to its maximum strength may be made.

The charger is in the form of a small box having a handle and also a hole in which one end of the magnet is placed.

The two ends are placed on a piece of iron which closes the circuit. The magnet-charger is raised to the curved part of the magnet three or four times, each time closing and opening the switch. The

charger is then held over the top of the magnet, and the same operation is repeated with the switch open. The magnet is now fully charged.

The simplicity of the operation is its chief recommendation.

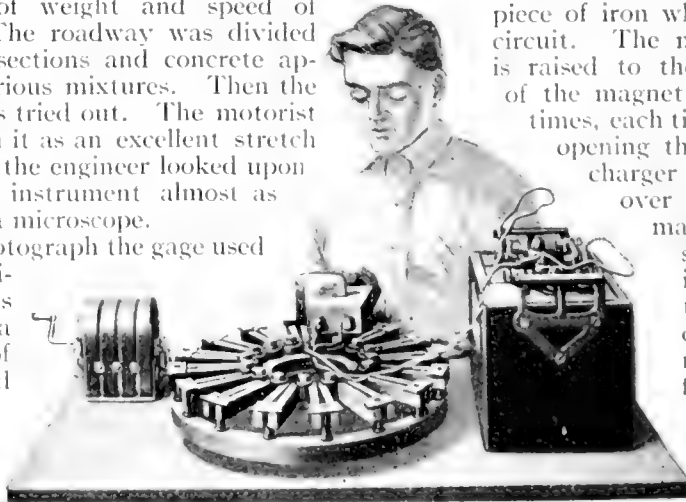

Rejuvenating your Ford magneto is the work of five minutes with this new specially designed charger

Maybe you have special needs. Write to the editor about anything within the scope of the magazine. He will be glad to help you.

**Lifting Street Cars with a Powerful Electric Hoist**

THE lifting of street and interurban cars without the use of a hoist or crane is tedious and expensive. A dozen men or more are required, and the task consumes much time. The hoist shown in the accompanying illustration does its work with practically no human aid and cars are lifted and removed from railroad flat-cars in five minutes.

The hoist can be used for loading as well as for unloading cars, the operation being about the same. Four long lifting-chains, after passing over the chain-sheaves, are wound on right and left hand-drums situated at the top and center of the hoist. The shaft on which both drums are mounted carries an ordinary railway gear. Lifting power is supplied by a motor.

It takes but five minutes to remove a car with the hoist. The railroad flat-car on which the street car is loaded is run under the hoist. After the chains have been secured to blocks, which have been put under the car to be lifted, the car is hoisted high enough so that the flat-car can be pulled out from beneath it. The street car is then lowered to the rails.

The electric hoist does not confine its usefulness to the lifting of street cars alone. It has been used successfully in unloading heavy motor-trucks from railroad flat-cars and for temporarily suspending automobiles and other vehicles.

Its advantage is that it obviates the use of a pit.

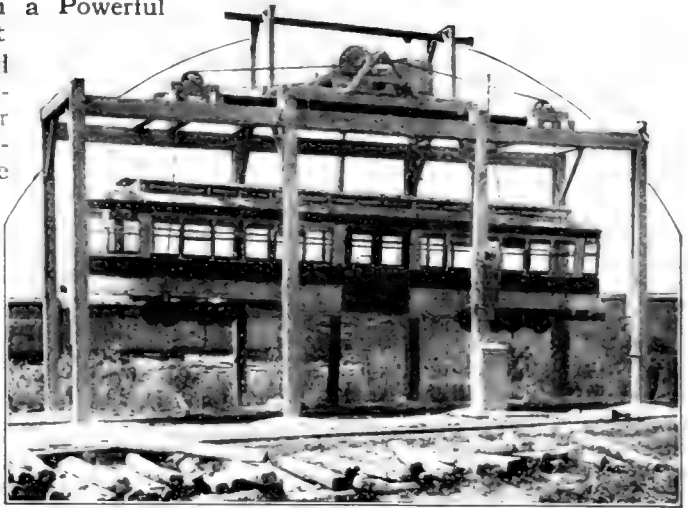

With practically no human aid the electric hoist lifts and removes street cars from railroad flat-cars in five minutes

**Getting Drunk with a Pair of Ordinary Opera Glasses**

THE same sensations, minus the alcohol, experienced by an intoxicated person who is trying to walk in a straight line or on a narrow sidewalk which is only thirty feet wide, can be had by anyone who takes the trouble to draw a straight line on the floor and then look at the line through a pair of opera glasses in a reversed position.

After the glasses are focused try to walk on the line. You will find it impossible to follow it closely. The line will look like an ink scratch on a surface miles away and the closer you look and try to follow the line the more vexed your vision becomes and as a result your feet wander from side to side, getting farther away from the line all the time.

Even with the naked eye it is difficult to "walk the chalk" for any distance without growing dizzy and staggering suspiciously.



Reverse the opera glasses and walk on the line if you can

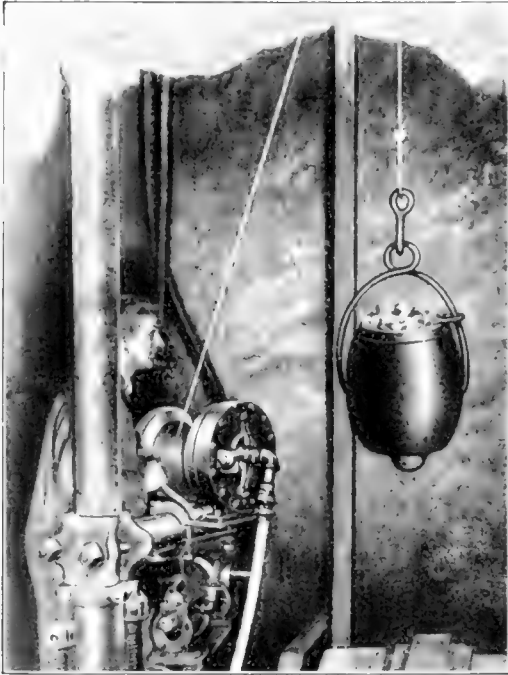

There are no exposed levers or flywheels and the motor is enclosed in a casing

#### A Tiny Portable Hoisting Engine of Dual Power

**A**DIMINUTIVE but powerful hoisting engine that handles loads of one thousand pounds or less over distances of several hundred feet has been designed recently. It is operated either by steam or by compressed air.

This little hoist, said to be the smallest practical one of its kind, has the additional feature of safety, having no exposed levers or flywheels. It is designed for rough service, particularly for use in mines and quarries. It is portable, and can be mounted almost anywhere—clamped to a pipe or column or bolted to the wall.

Both for safety and durability, the motor is contained in a casing. The brake is a band-type operated by a worm—a screw with a long pitch—to constrict it, so as to give greater holding power.

#### Why the Rain Follows the Thunder and Lightning

**W**HYY does a heavy downpour of rain often follow a clap of thunder? Not, as is popularly believed, because the thunder jostles the cloud particles together into raindrops. In the violent turmoil between the positive and negative electricity in a thundercloud there will be places where the production of drops, by condensation, and their subsequent breaking up proceeds more rapidly than elsewhere. Hence in these places there will be more drops to fall as rain, and also more electrification, the rainfall occurring about the same time as the flash. We have, then, starting toward the earth at the same time, light, sound, and raindrops. The light, traveling at a speed of about 186,000 miles per second, reaches us almost instantly. The sound travels far more slowly—about 1,090 feet per second—but the rain falls much slower still. Thus we observe, first, the lightning, then the thunder, and then rain.

#### A Tobacco-Can with a Roll of Cigarette Papers Attached to It

**F**OR the convenience of smokers who prefer to roll their own cigarettes, Bertram A. Rose, of Fort Worth, Texas, has invented a cigarette-paper holder attached to the under side of a tobacco-can cover.



The paper is pulled out and the edge of the box-cover cuts it

When he wants to roll a cigarette the smoker pulls the paper outward and downward from its position on the roller, and then tears it off for a long or short smoke by using the outer edge of the lid as a cutter.

In pulling the paper outward and downward over the edge of the lid the "roll" is taken out. The paper may be perforated to facilitate the tearing and cutting operation, but the inventor relies mainly upon the outer edge of the lid for cutting each piece of paper as it is pulled from the roll and pressed against the tin.

# The Handiest Barn Ever Built

Hay, grain and water are all stored in the center

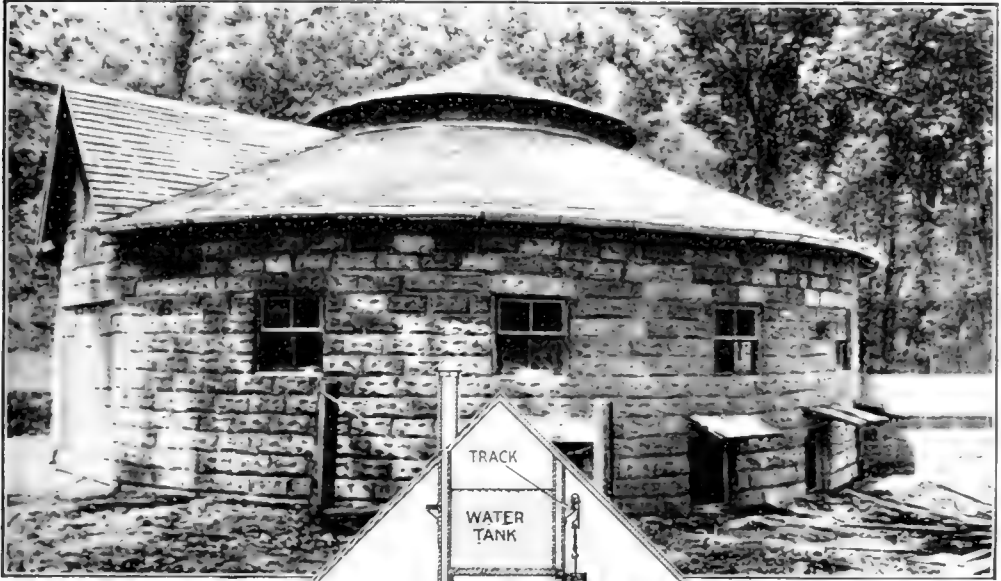

The barn consists of two cylindrical cement walls, one within the other

**A** BARN, built like a fort, with the feeding-hoppers and watering-troughs grouped together around the center of the building, has been patented by Peter O. Swedberg, of Marshalltown, Iowa. The barn is constructed of cement blocks. It consists in the main of two cylindrical walls, one within the other.

Within the inner or central barn chamber are kept the troughs and feed-hoppers, together with chutes leading to them from chambers in the upper part of the barn.

No time is wasted in traveling from one end of the barn to the other to feed the cattle: for hay, grain and water are all at hand in the central portion of the barn. Here also are located the troughs and hoppers in front of the stanchions radiating from the central chamber.

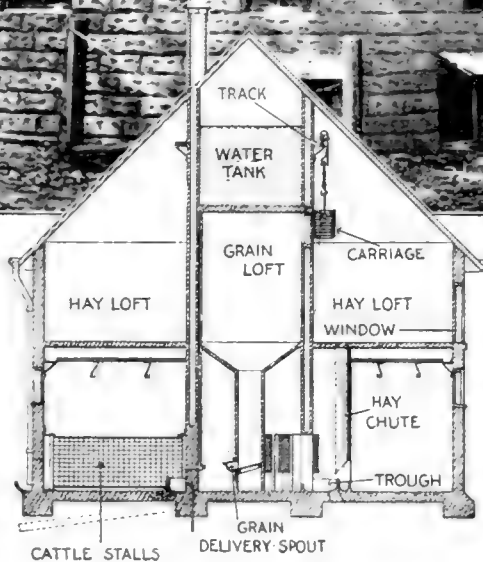

The building is forty feet wide, with a sixteen-foot feed-room

The building measures forty feet in diameter with a sixteen-foot feed-room in the center. The outside wall is eleven feet high. The wall of the inside chamber or feed-room is twenty

feet high. A five-foot water tank is provided at the top.

One of the principal time and labor-saving features is an elevated track or runway which extends around the interior of the barn. On the track is mounted a carriage which supports a receptacle for transporting material from one side of the building to the other.

Provision has been made for heating the interior by a stove. A pipe runs from the left of the center space up through the conical roof. Near the stove is a spout from which fine food or grain is supplied. When hot water is needed for mash it is readily available.

# A Modern "Newspaper Maker"



Over two hundred inventions are incorporated in the mechanism of the machine. The coordination of the various parts of the folder was obtained by distributing air pressures and vacuums so that the paper is carried, not pulled, along

**T**HE speediest printing press in the world, having an hourly capacity of 65,000 newspapers, has been completed for the New York Herald. Henry Wise Wood is the designer and constructor. The new press embodies a vast number of improvements, so that in

spite of its tremendous speed the attention it requires is even less than that of the ordinary newspaper press. It delivers papers folded into either 8, 16, or 32 pages. Great difficulties were overcome before the folder was perfected. Principles of aeronautics were applied.

Sitting Down in Comfort on  
a Painter's Job

THE simple skill of the sailor evolved a seat in which he could paint the sides of his ship or repair his topmost rigging. It was merely a notched board set into a looped rope-end—a child's swing, except that it depended from one line instead of two. It was an uncomfortable, one-handed affair at best; yet it was, and is still, used by steeple-jacks, painters and such like, with small variation. The inventive mind had passed it by until recently, when an employee of a New York electric company transformed the old swing into an aerial easy-chair.



Adjustable stirrups hang from the front of the chair and enable the painter to stand up when he wishes



Short chains to hold pots and brushes depend from the back of the seat

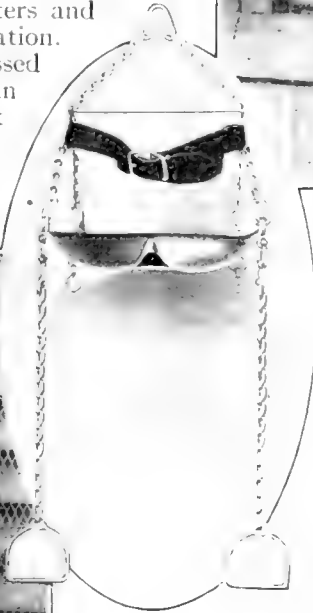

The chains are braced just above the waistline by a steel bar



and prevent the cramping strain of the weight of the legs and feet upon the under-thigh muscles. They also add tremendously to the flexibility of action. With these stirrups it is possible to straighten the body into a standing posture and to maintain balance. A belt fastens around the waist through the triangular links at the brace-bar and allows two-handed action under the most trying conditions.

This belt makes accidental falling out of the chair an utter impossibility. The suspension-ring is equipped with a hook designed to simplify the hitching of the hauling-rope, and holds the hitch securely. Short chains depend from the back of the seat, on which pots, brushes or tool-kits may be hooked. These chains are equipped with "sister" or trap-hooks to secure the articles carried.

The painter simply adjusts the seat, buckles the strap and pulls himself up to the desired height

The seat is a form-fitting, pressed-steel affair suspended at four points to insure balance. The chains are braced at a point just above the waistline by a steel bar. This prevents pinching and gives the chair a better "hang." Adjustable chair-stirrups hang from the front of the chair



# Is Jupiter Launching a Moon?

The mysterious Great Red Spot on the biggest of planets and what it means to astronomers

**I**F JUPITER were cut up into one thousand three hundred pieces, each would be larger than the Earth. All the planets together do not weigh half as much as Jupiter. Only the Sun surpasses Jupiter in size.

A year on the planet Jupiter is equal to twelve of our years. Jupiter rotates on his axis in less than half the time of the Earth. But because of the planet's enormous size, the rotation speed is much higher. While the Earth travels 17 miles a minute, Jupiter travels 466 miles a minute. If Jupiter turned on its axis a little faster, it would burst as some flywheels do, when they exceed a safe speed.

Jupiter may be regarded either as a decaying sun or a developing earth. He has not yet had time to cool. He is a great globe of gaseous and molten matter—the most extraordinary planet in the entire solar system.

Because Jupiter is a semi-sun, there is some reason to believe that he possesses inherent light of his own. But astronomers are by no means in accord on this point. Perhaps the clouds, that certainly exist on Jupiter, owe their origin to some other heat than that of the Sun. In other words, Jupiter possesses stores of heat within himself.

Look at Jupiter through a fairly powerful telescope and you will see two broad belts with two or three narrower ones on either side. They lie practically parallel to the planet's equator. Sometimes they are narrow, and when they are very narrow, there is an increase in their number.

Since Jupiter is in a more or less fluid condition, he is surrounded by a dense, cloudy envelope. In all likelihood, the belts are simply rifts in this envelope, exposing the more solid portion of the planet beneath. Not much is known about the belts. While they remain unchanged for months, the fact that they do alter their appearance has led to the assumption that great atmospheric

storms take place on Jupiter.

Occasionally Jupiter's belts appear spotted. Just what these spots are, no one knows definitely.

It was in 1878 that the great, mysterious Red Spot of Jupiter, which has puzzled astronomers for many years, was first observed at Brussels by M. Niesten. It was 30,000 miles long one way and over 8,000 miles another. The Earth might figuratively have been dropped into the Red Spot without touching the sides.

For three years, the Great Red Spot was a constant object of study. It completed its circuit about Jupiter in nine hours, fifty-five minutes and thirty-six seconds.

What is the Great Red Spot? A volcano, said some. That is impossible, because it floats freely. It has a strange effect on its surroundings; it has the property of excavating them, as it were. There is a deep bay in which the spot, rather dim now, is located.

In describing the drawing appearing on the opposite page, Mr. Scriven Bolton, the English astronomer who made it says:

"It is propounded that our earth, when once in a plastic condition, rotated on its axis so swiftly that the matter at the equator could not adhere together, and a breach caused a portion to be fractured, which portion gradually separated from the parent planet. So, apparently, in the case of our cousin-planet Jupiter, whose rotational velocity at its surface is as great as ours used to be, there is at present a phenomenon which suggests an epoch in the evolution of moon-making. That puzzling object on the surface, known as the Great Red Spot, is not a fixture of the surface, or we might regard it purely as a volcanic vent emitting hot vapors. Its constituent properties have never been ascertained. . . . It moves round with the planet's axial rotation. This is especially noteworthy from the fact that theory tells us that our moon, in its early stages of evolution, was carried round with the earth's axial motion, all the while just grazing the surface, and that its distance therefrom increased through countless ages, and is increasing. The inference denotes a Jovian moon in embryo."

# Is Jupiter Launching a Moon?

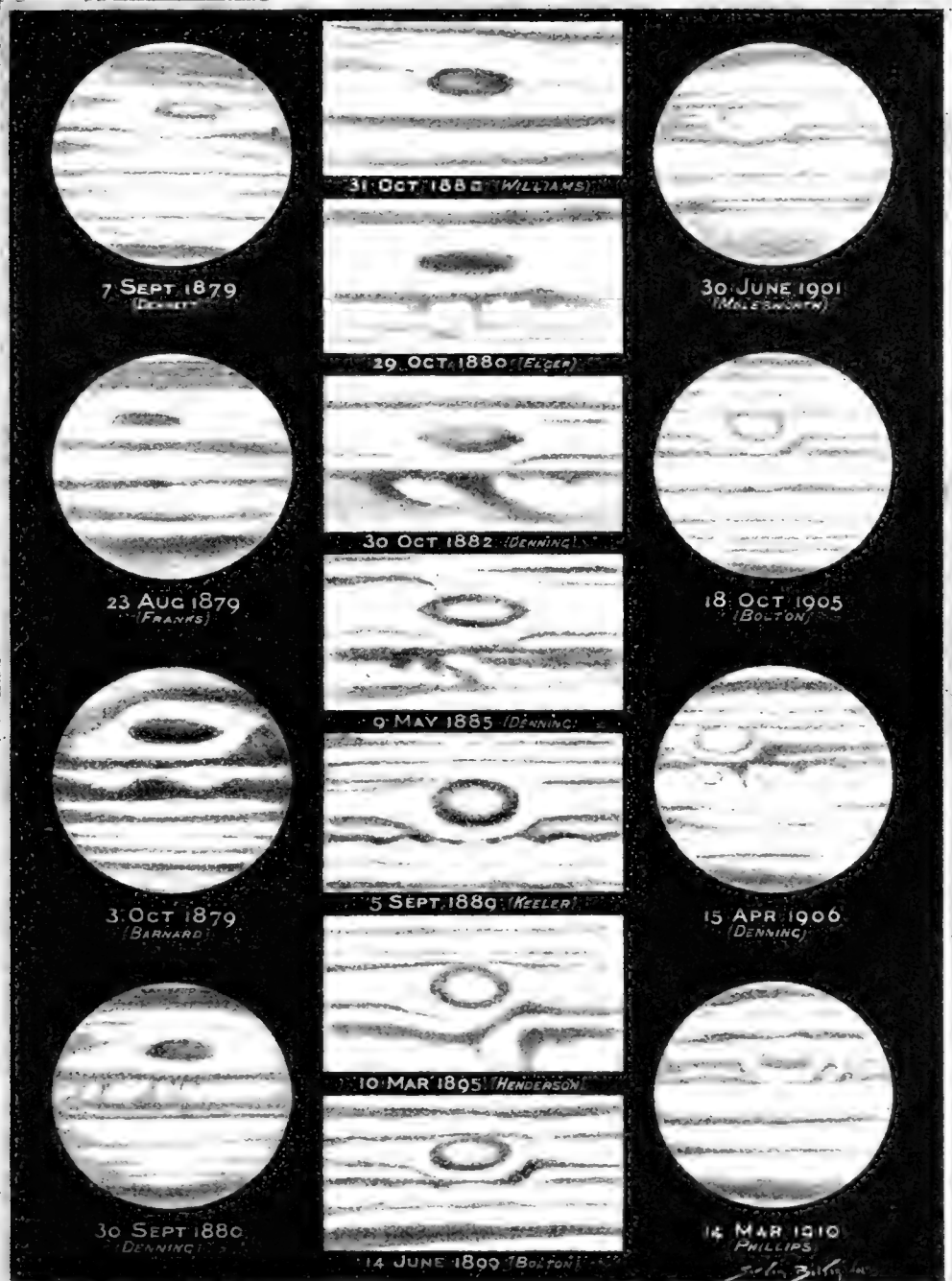

From drawing by Scriven Bolton in Illustrated London News

The Great Red Spot on Jupiter's surface is not a fixture of the surface. It moves around. This is noteworthy from the fact that theory tells us that our moon, in its early stages of evolution, was carried round with the earth's axial motion, all the while just grazing the surface, its distance therefrom increasing through countless ages. The inference denotes a Jovian moon in embryo

# Serving Yourself to a Shave

You don't tip anybody and you don't have to wait



You step in and do the job yourself as quickly as your personal skill will permit

Down one side of the room are clean, tile-floored, well-lighted booths provided with all the necessary shaving equipment

**O**N FIFTH Avenue in Chicago is the first "shaveteria" ever built. You serve yourself to a shave there, just as you serve yourself with food at a cafeteria.

When you are in a hurry for a shave, and you know that you could do it twice as quickly as it could be done in a barber's chair, you step into the shaveteria. Down one side of the room are clean tile-floored, well-lighted booths. Each is provided with porcelain lavatory, hot and cold running water, and all things necessary.

You do not have to wait. You step right in and do the job up yourself.

**A Novel Device for Generating Fresh Air in Submarines**

**A** NEW process for supplying pure air to submarines has been discovered. The inventor, William G. Bond, of Wilmington, Del., recently demonstrated the use of his apparatus by remaining in a test chamber three feet by four feet by six feet for seven hours with only the air furnished by his device. The air is purified by a chemical reaction between carbon dioxide and certain solutions exposed to the atmosphere of the chamber. The carbon is absorbed and the oxygen liberated.

The test room used was entirely surrounded by water. Mr. Bond entered the tank, clad in a bathing suit and supplied with reading matter, food, air-testing apparatus and the chemicals. He kept in communication with the observers on the outside by means of a telephone. At a stated time, the supply of oxygen furnished by the apparatus was cut off and he remained for three-quarters of an hour longer. Though the air had been perfectly wholesome for seven hours, at the end of the forty-five minutes the inventor emerged breathing very heavily.

The value of this discovery to the submarine is yet undetermined. Its advantages are the simplicity of operation and the low cost of installation and

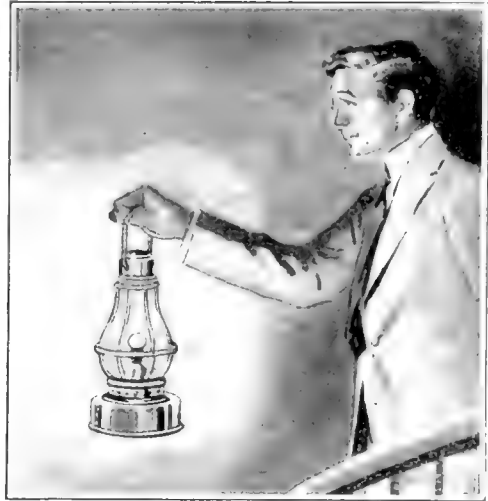

An electric lantern is cleaner, cheaper, and gives a much brighter light than kerosene

**Electric Hand Lantern Costs Less Than a Kerosene Burner**

**A**N electric hand lantern has just been placed on the market for people who have a use for the hand lantern, but who find most of them too expensive. It sells for the sum of twenty-five cents and gives as good a light as many of the more expensive models. The lamp proper is a tungsten burner which is turned on and off by a screw. It is six inches high.

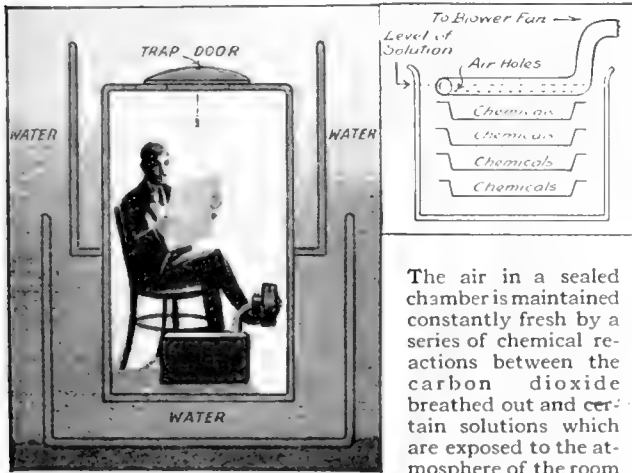

The air in a sealed chamber is maintained constantly fresh by a series of chemical reactions between the carbon dioxide breathed out and certain solutions which are exposed to the atmosphere of the room

**Electric Ranges Are Becoming Popular**

**O**NE of the most promising developments of the present time is the increasing use of electric ranges in the home. This is especially true in Canada where the rates are remarkably low. In many cities, the price per kilowatt-hour is less than three cents, and in some it is as low as one cent. The main objection lies in the fact that an electric stove installation is expensive. Tearing out old wiring and replacing it with new is almost as costly as

maintenance. Let it be said, however, that any practicable method for ventilation of the submarine will be welcomed.

the range itself. Thus the best and most economical plan is to make the proper installation when the house is first built.

## Using the Telephone on the Rifle Range

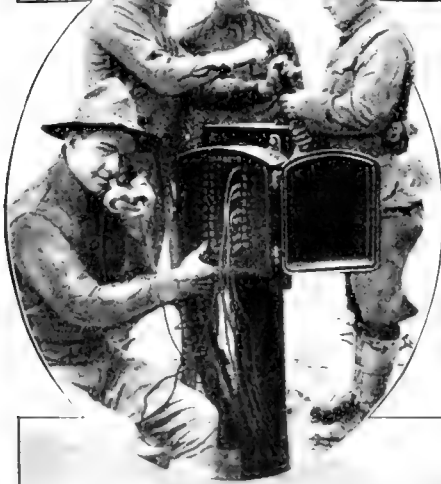
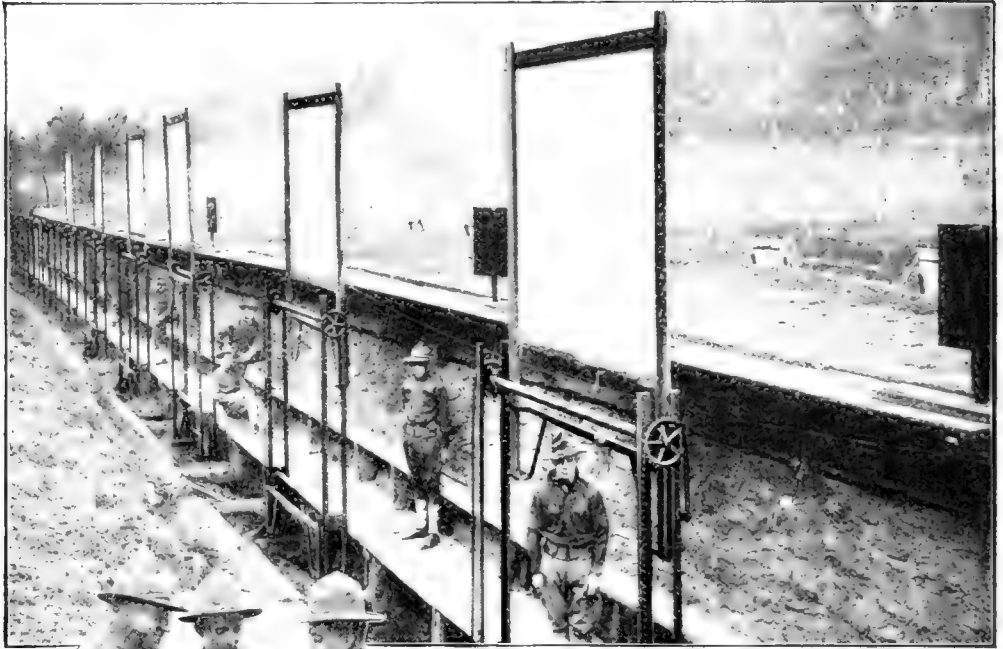

On the rifle range of the Georgia State Militia, at Augusta, scoring is done by a telephone system. A telephone in the firing pit is operated from a central station box on the firing line; so is an iron buzzer-box in front of each target. When the buzzer sounds, the target is pulled down, the shot located and another target set up

At left, the telephone box on the firing line. The operator keeps in constant communication with the men in the firing pit by means of the telephone and the buzzers located one at each target

Below, a busy firing line. As one target is pulled down and the shot noted the target in the other sash goes up automatically, so that a target is always in place above the pit. The buzzer-cords to the pit are led through the pipe-line shown



Two Mines Which Make Marine Warfare More Terrible

THE accompanying illustrations show two different types of mines which have been devised since the great war started. The mine with the periscope attached is said to be the latest Teuton lure for British skippers who are seeking the \$2,500 reward offered by the British Admiralty for ramming a submarine. Not long ago one of these periscope mines was sighted in the English channel by a steamship captain. Taking it for the periscope of a submarine the captain ordered all speed ahead, in an attempt to ram what he thought to be a lurking U-boat. As he was fast approaching it he noticed, to his bewilderment, that it did not move. He became suspicious and when almost upon the periscope, ordered his pilot to give it wide berth. Later he investigated cautiously and found that the periscope was attached to a huge mine.

The other mine is the invention of Giovanni Elia, of Paris, who believes that it is the most effective of any mine now in use. His mine cannot explode by coming in contact with strong tides or striking slight obstructions in the water.

It is anchored, and, when a moving ship comes in contact with it, a shock is produced which is absorbed entirely by the circular frame projecting from the body of the mine. Under the influence of this shock three screws in the firing mechanism are cut through.

In the meantime the mine, having come in contact with the vessel, turns, under the effect of the friction of the hull of the ship. This turning movement cocks a striker and then releases it, causing the explosion. The mine can be manipulated and transported without danger prior to its being submerged.

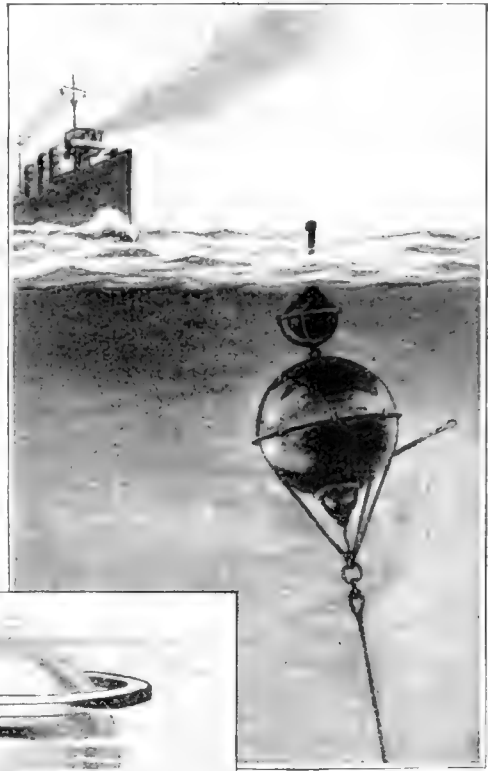

Above: The periscope mine—the Teuton lure for British skippers. The periscope is merely attached to the top of an anchored mine. At left: A mine which cannot explode unless struck by the hull of a ship. The circular frame is a shock absorber

The Deepest Known Place in the Ocean

THE greatest ocean depth known is 5,269 fathoms, or 31,614 feet. It is about seventy-five miles southeast of the Island of Guam. This figure was obtained in 1899 by the U.S.S. *Nero* when running a line of soundings to locate the Honolulu-Manila cable. The mean depth of the entire ocean is about 2,100 fathoms, or 12,600 feet.

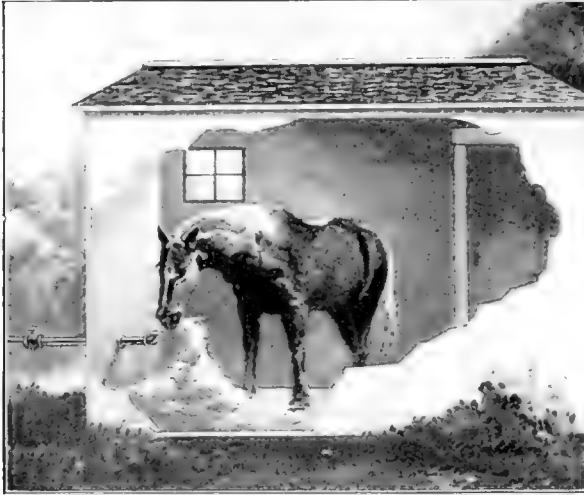

While the condemned horse eats, the gas enters the air-tight stall, causing him to die peacefully and painlessly

#### A Humane Method of Destroying Horses with Illuminating Gas

A NEW equipment for killing condemned horses with illuminating gas has been installed in the Denver City Pound. A small air-tight stall is connected with the city gas-main. While the horse is munching his oats or hay from a manger in one side of the stall, the gas enters from a pipe directly underneath. The animal gently and peacefully subsides into insensibility.

The stall is ten feet long, seven feet six inches high, and four feet wide. It was devised by Walter C. Cox, of Denver, Col., who claims that stables or buildings can be adapted to the purpose by making them air-tight. He has also devised a leather inhaler with a three quarter-inch hose connection and a strap to pass around the horse's nose. The inhaler is used where a stall is not available.

#### New Apparatus for Setting Broken Bones

THIS apparatus for setting broken leg bones, devised by John B. Hunt, Mansfield, Ohio, makes it possible for the patient to move the injured leg to a limited extent without danger of displacing the fractured ends. The bones are kept in correct alinement, as is customary in surgical practice,

by the use of an adjustable weight. But the apparatus for suspending the weight is novel. An overshoe-form is laced over the foot. To this overshoe straps are attached which run over rollers mounted in slots in the upright end-board of the frame. These straps are attached to the weight-strap, which runs up over a roller suspended from a scale. The other end of the strap has a weight attached to it.

Movement of the limb up or down or longitudinally within restricted bounds is possible, as in doing so the suspended weight is raised or lowered without altering the tension on the limb. This alleviates the discomfort,

to some degree, of a trying situation. The sides of the apparatus are hinged to permit of the letting down of either side in order that the limb of the patient may be placed in it easily, as shown in illustration.

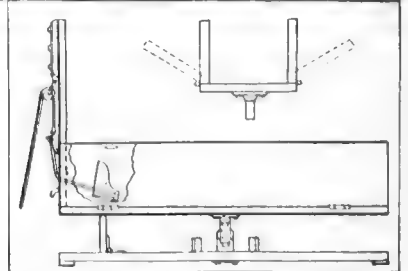
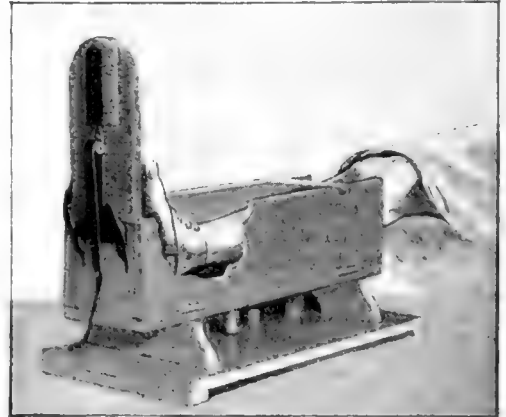

The apparatus in use. Details of the construction, and a cross-section showing how the sides open and close on hinges



Rubber-Ball Fender to Protect Unwary Pedestrians

IF THE plans of a wildly imaginative Texan inventor go through, all motor vehicles will soon be equipped with a huge rubber ball, projecting out in front. And its purpose? Oh, it just gently bumps the careless pedestrian instead of knocking him senseless or dead. What matters it that the ball will be more than a yard in diameter when puffed out to its capacity?

Of course you think that the rubber-ball safety-guard bounces the careless pedestrian to one side, allowing the automobile to proceed on its way. You are wrong. It is intended to envelop the victim in its folds. But that is not all. It applies the brake automatically when a careless man sinks in its expanse. This is accomplished by means of a compressed-air arrangement. Edison will turn green with envy when he reads about this in the POPULAR SCIENCE MONTHLY.

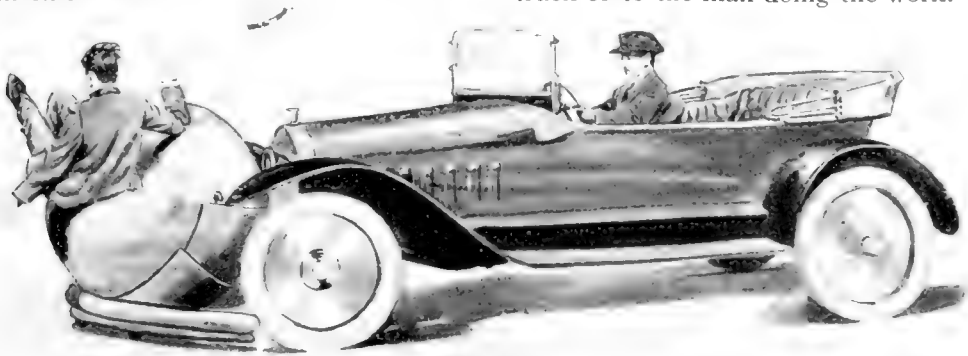

The ball envelops the pedestrian in its folds and automatically applies the brakes

An Automatic Brake for Freight Trucks

A SAFETY-BRAKE which can be applied to the ordinary truck of the kind used in warehouses has been devised by Jacob H. Balkena, of Grandville, Mich. The brake is arranged to bear against opposite portions of the peripheries of the rear wheels of the truck.

The brakes themselves are operated by opposite levers, which, in turn, are connected with a rod extending lengthwise under the body of the truck and operatively connected at its forward end with an upright lever which may be readily grasped and operated by the man handling the truck.

With this brake a truck loaded with eleven hundred pounds of mid-dlings or any other commodity can be safely rolled down a thirty-per cent incline from freight car to warehouse without the slightest danger either to the truck or to the man doing the work.

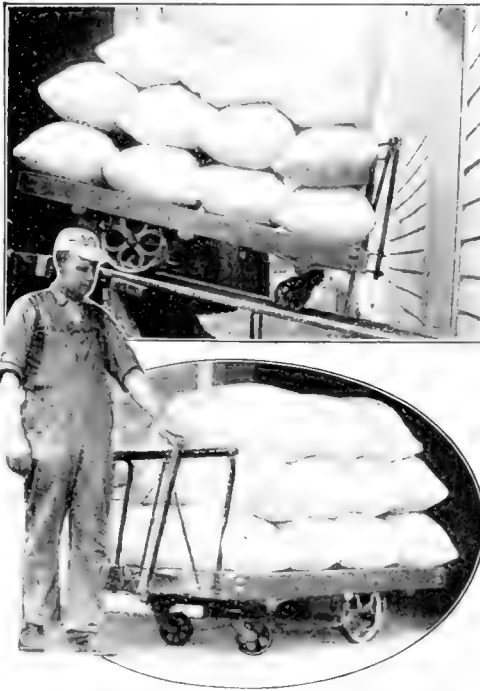

Heavily loaded trucks can be rolled down an incline without danger to the freight

### Cleaning and Sorting Beans by Machinery

A MACHINE for cleaning and sorting beans has been invented by D. E. Krause of Sobieska, Wisconsin. First, the beans are poured into a large hopper-like receptacle. From this they are shaken down an inclined chute which has a wire screen as its bottom member.

Under-sized beans, small stones and dirt drop through this screening and are thus eliminated. From this inclined chute the clean beans fall down on to an endless conveyer-belt.

As the belt rolls along, the workman sitting in front of it picks out any black or imperfect beans.

The device makes it possible to clean and sort a large quantity of beans in a remarkably short time. It does the work thoroughly, employing only one man.



One workman using the machine can clean and sort a large quantity of beans in a remarkably short time

### Electrical Extraction of Gold from Black Sand

THE black sand concentrates of the placer and quartz mines in western United States contain values in gold as well as in other rare metals. A recent invention based on electrolysis is now being demonstrated in various localities

for the extraction of the gold, which often exceeds two hundred dollars per ton.

The principle involved in the operation will be understood by reference to the drawing. Carbon bars are mounted in slots in the sides of a

wooden trough twelve inches wide and fit in depressions in the bottom of the trough, these depressions containing a quantity of mercury.

The space allowed between the carbons and the surface of the mercury is less than one-eighth of an inch. The sand is placed in a hopper perforated at its lower edge with a number of small holes. The electrolyte is stored in a barrel. A pipe furnishes pure water, which flows directly into the trough.

In operation, the positive and negative wires of an eight-volt generator are connected with the carbons and with the mercury respectively. The correct amounts of the electrolyte and pure water are turned into the trough. They mix at the head of the trough, and, in passing the hopper, gradually wash the sand down the trough through the space between the carbons and mercury, where the current, acting upon the gold, deposits it in the mercury, with which it amalgamates and from which it is extracted.

To all appearance the sand undergoes no change whatever, but an assay of the tailings seldom gives a trace of the gold.



The water and the electrolyte mix at the head of the trough and in passing the hopper wash the sand down

**Steaming Frozen Ground  
for Gold**

OVER much of northern Alaska and British Columbia the ground is forever solidly frozen for many feet beneath the surface. During the warm summer months, where the overlying moss has been removed, the soil may thaw out for a few inches or feet, permitting placer mining to be carried on by hydraulic mining methods. For the most part this natural thawing is far too slow to prove practicable in a region where the working season is only a few months in the year. The ingenuity of man, therefore, has devised a method to assist Nature in her work. Long, hollow tubes, called "steam points," tapered at one end and enlarged at the other



Long, hollow tubes are driven into the ground in rows and steam is forced through them for several hours

to withstand repeated blows and carrying a connection to a steam line, are driven in rows across the face of the ground. Steam under pressure is forced through these pipes for several hours until the section is thoroughly thawed. Then the points are removed and driven into another nearby section.

Much of this work is carried on both at the surface and beneath the ground in drifts, during the winter months, the gravel removed being piled in great dumps to await the summer season of abundant flowing water.

**Look Out! Perhaps the Man You're  
Talking to Wears a Detectaphone**

A PATENT has been issued to William Heymann, of Washington, D. C., on a device which records on a graphophone drum whispered conversations, without the speaker being aware of the fact.

The receiver, which is of the usual detectaphone type, is to be worn beneath the shirtfront, and the electric battery and cylinder of the recording graphophone are to be hooked to the wearer's belt. Release a wound-up clock-spring and the needle of the graphophone traces the zig-zags produced by the sound waves.



The receiver is worn beneath the shirtfront and the graphophone is hooked on the belt

Recording the Vibrations of a Motor-Truck Spring



The paint is first vaporized and then forced through hose and sprayed on the cars by means of compressed air

**T**HE novel device illustrated was recently designed to enable a truck manufacturing company to judge what springs are best adapted for its vehicles.

The device consists of a hollow drum mounted on a vertical axis and carried in an open-sided box attached to the truck body at the rear of the driver's cab. It is revolved by gearing from the front wheels of the truck through a flexible cable. A blank strip of paper is fed around the outer circumference of

The Hose Is Mightier and Quicker Than the Brush

**I**F KIPLING had only waited long enough before saying it our picture might have given him his idea about painting with a comet's tail for a brush and the sky for a canvas. However, the painters shown in the accompanying illustration are not artists and their canvas is not the sky but two brand-new steel box-cars which have just emerged from the shop.

This is the fastest and most economical method of painting yet devised. The paint is first vaporized and then forced through the hose and sprayed on the cars by compressed air.

While the photographer was adjusting his camera for a snapshot the ends of both these cars were painted, which gives an idea of how rapidly the work is accomplished.

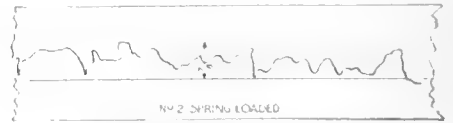
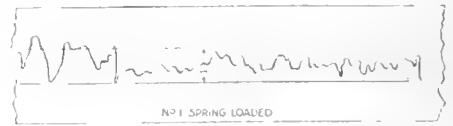

Inscription of a record on the strip of paper around the drum

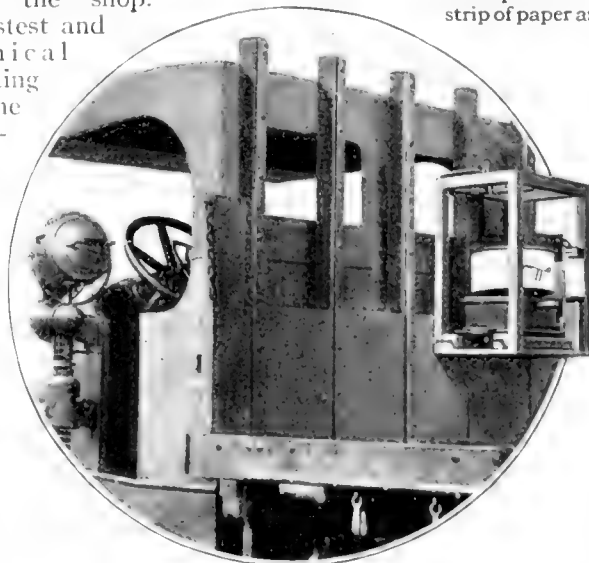

The device is carried in an open-sided frame attached to the body of the truck at the back of the driver's cab

the drum from a roll beside it.

While the truck is running the spring vibration is proportional to the motion between the body, to which the device is fixed, and the axle. This record is inscribed on the sheet around the drum by means of a pencil carried on a swivel by a spring-arm.

**Giant Slabs of Marble to Commemorate Abraham Lincoln**

THE largest stone in the great Lincoln Memorial has been swung into place. There are three of these slabs of marble all of the same size, and they are reputed to be the largest ever set in any structure in this country. Each is more than six feet high and more than nineteen feet long and weighs about twenty-eight tons.

The big blocks came from a quarry in Colorado which is situated just below the perpetual snow-line of the Rockies, on the eastern slope of the Great Divide. It is the boast of this quarry that it can get out in one solid mass a block of marble as big as any derrick can lift. The fact is that modern mechanical appliances for the hoisting of giant slabs have transformed quarrying. While the old-time quarrymen worked under unfavorable conditions, and occasionally succeeded in shipping a large slab to a customer, the modern man works with improved apparatus and deals in tons instead of pounds. The strides made in transportation facilities enable

him to ship an expensive piece of stone with the assurance that it will reach its destination safely.

According to Henry Bacon, the architect of the Lincoln Memorial, there are more than eight hundred pieces of stone in the structure. These weigh from twelve to twenty-five tons each. No other piece of architecture in the world can boast of such construction. It reminds one of the giant stones of the pyramids of Egypt.

**Meerschaum as a Building Material in Spain**

EVEN the most aesthetically inclined of our American millionaires would hardly consider the luxury of living in a residence built of meerschaum as within the range of their fortunes, yet there are many unpretentious houses of this material in the Spanish town of Vallecas, near Madrid, where a coarse variety of this substance may be found.

Oddly enough, just across the Straits are the Moroccans, who have discovered that still another variety of meerschaum lathers freely and makes a good substitute for the ordinary toilet soap.

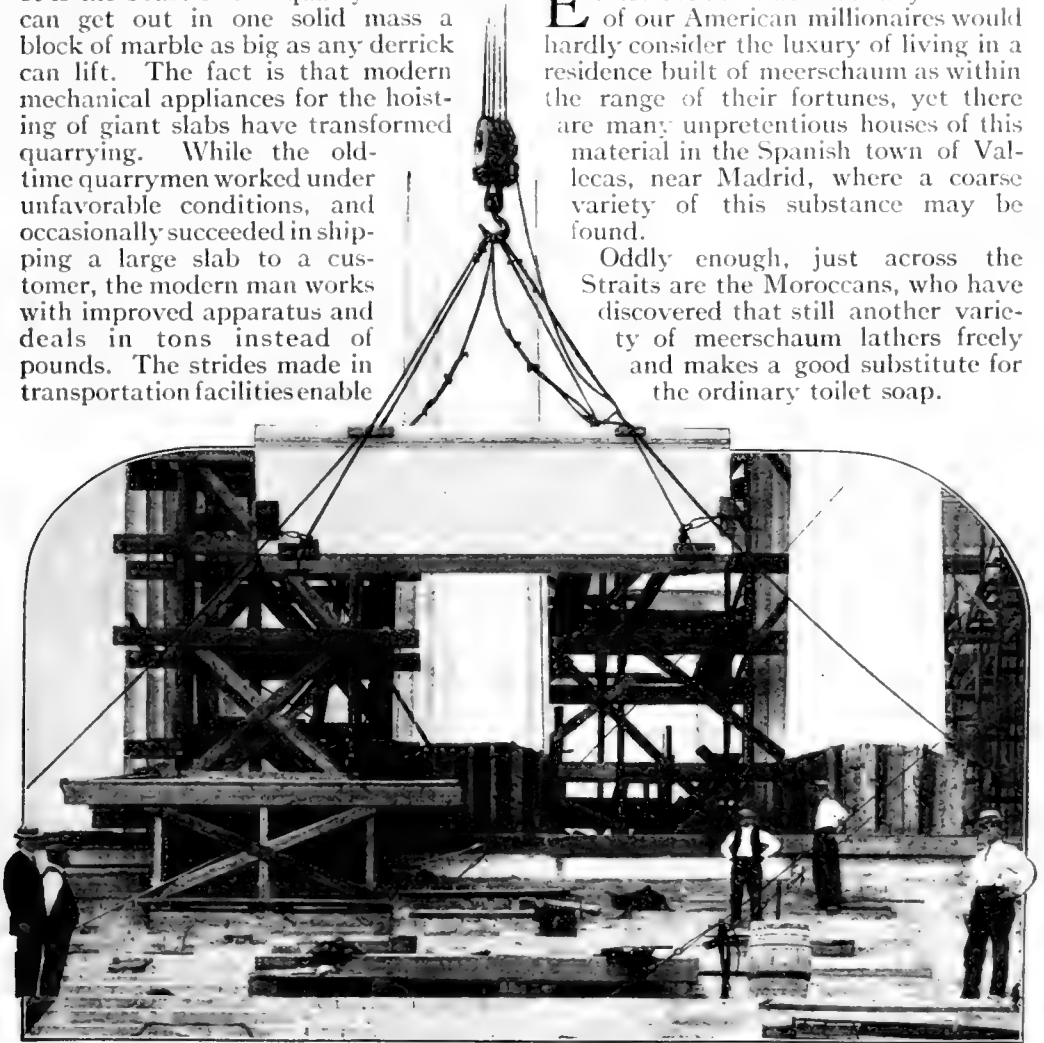

The largest pieces of marble ever set in any structure in this country have been swung into place in the Lincoln Memorial. Each one of these giant slabs weighs twenty-eight tons

# There's No Place Like a Mechanical Home

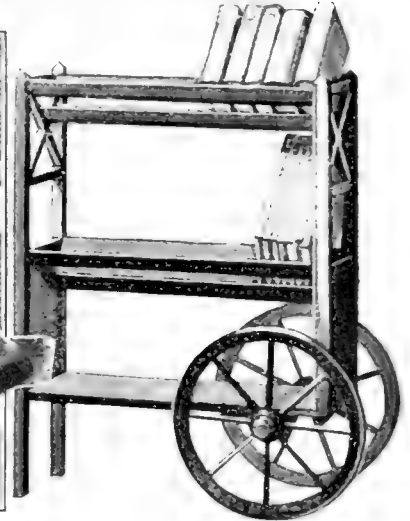

Above: An automobile seat converted into a handsome and comfortable porch rocker

Above: A mahogany book wagon will carry your books and hold them in readiness

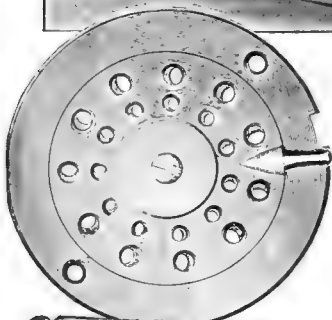

At left: A sink strainer with a revolving center plate to prevent water running out of the sink

At left below: A lemon and sugar dish. The lemon dish is of engraved glass; the sugar rack above is of pierced silver

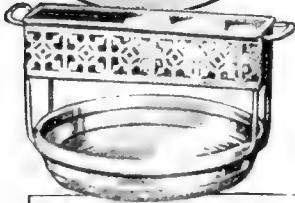

At right: An electric heater for the kettle, which can be readily attached



Above: A combined corn-holder, nut-pick and bottle-opener. It is most effective in holding an ear of corn

At left: A floor-brush constructed like a fountain pen. The handle is hollow. It contains water which is automatically fed to brush

At right: A flesh brush attached to a strap makes it easy to scrub your back

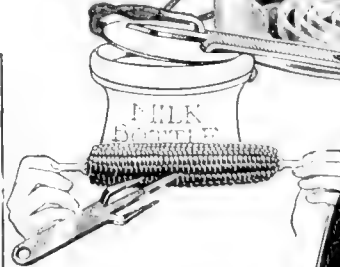

# Here They Are: The Newest Things for the Home

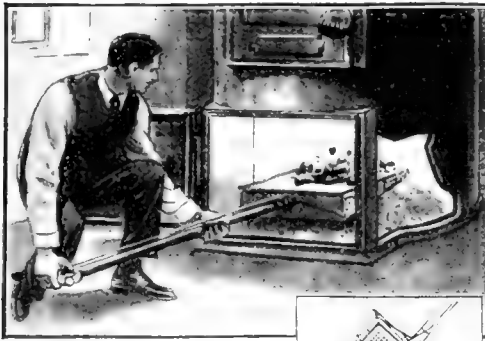

Above: A shovel ash-sifter which saves coal. The ashes sift down into the shovel and the lumps of usable coal or coke remain on top

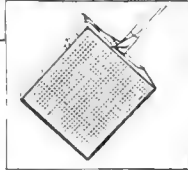

Above: A bathtub seat which partitions off a part of the tub so that it can be used as a foot bath, sitz-bath or for bathing little children

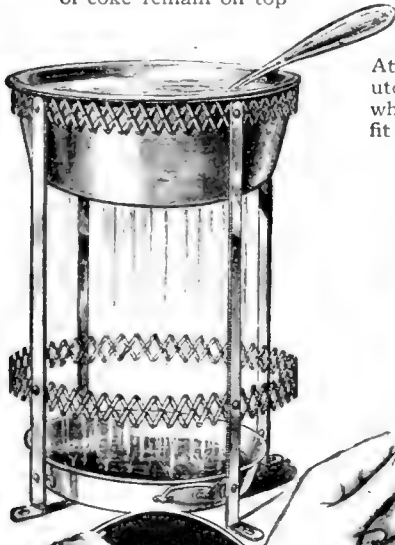

At left: A collapsible utensil holder and strainer which can be expanded to fit pans of almost any size

Below: A clothesline holder with the rope wound around a spool

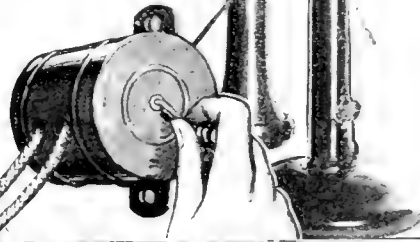

At left: A telephone lock which clasps the standard just above the receiver-hook. It is built in three curved sections and operates like a bracket



At left: A foot rest fastened to the radiator affords an excellent means of warming the feet

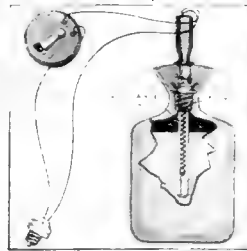

Above: A hot water-bottle heated by a resistance coil in a hollow tube



At right: A small electric motor freezes the ice-cream. Connection is made with any available electric light socket



# Our Bad Tempers

What makes you angry? Why do you fly in a rage when the soup is salty? Blame it on your grandfather

By G. Davenport

THAT bad temper is due more to an inside state than to outside conditions is demonstrated by the fact that the same mild stimulus causes so much more violent behavior in some individuals than in others. In other words it takes little or nothing to make some persons lose their temper. They lose it easily, just as children do, because they lack the braking power or ability to shut off this violent reaction.

Liability to outbursts of temper is confined to no stratum of intellect or social position. The choleric

may be rich or poor, stupid or intelligent. Bad temper is an emotional rather than a mental disturbance. Concerning the causes of this disturbance we know little. We know that over-eating and drinking, bad digestion, intestinal stagnation and exciting situations are contributory factors. But what may cause an irritable state in one may not ruffle another. To account for this difference, we are brought around again to the matter of individual constitution, *i. e.*, to the fact of heredity. In many cases that have come under institutional observation there is not infrequently a regular occurrence of tantrums at monthly or more frequent intervals. It would seem as though there were an accumulation of some substance in the body, in consequence of which the nervous system becomes so irritable that an explosion results from the most trivial cause.

Bad temper is especially frequent in families that contain epileptic, hysterical or insane relatives. Epilepsy and insanity, however, are not necessarily indi-

cated by outbursts of temper nor does a choleric temper invariably accompany these disorders; for there are mild tempered epileptics as well as maniacs. The paralysis of the braking mechanism upon which tantrums depend, seems, however, to occur most readily in those individuals whose nervous and other body functions are defective in other ways.

This tendency to outbursts of temper, whether periodic or irregular, is a return to an

infantile emotional condition. Children are more given to displays of temper, on the whole, than are adults,

just as monkeys are much more capricious, on the whole, than men. Thus ill-tempered families have either reverted, in this respect, to a more primitive condition or else they are retarded in the evolution of this trait.

Whatever may be the racial history of the trait, its present hereditary behavior is not obscure. We know that it is handed down in certain families from generation to generation without a break. That is to say, some members of each generation will possess this unsocial trait and others lack it. Those that show it, transmit it in turn; but those without it cannot do so. Traits that do not skip a generation are known in the language of modern heredity as dominant traits. Just how complete may be the dominance will depend on the hereditary history of both parents. There is an hereditary combination possible that will produce 100 per cent choleric; that is when both parents are choleric and belong to pure choleric strains.

The accompanying charts illustrate

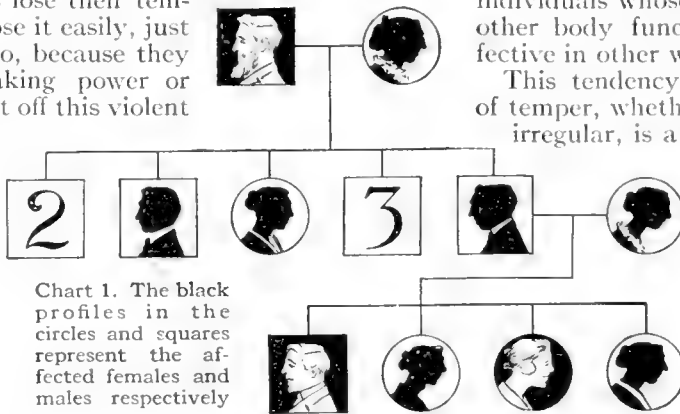
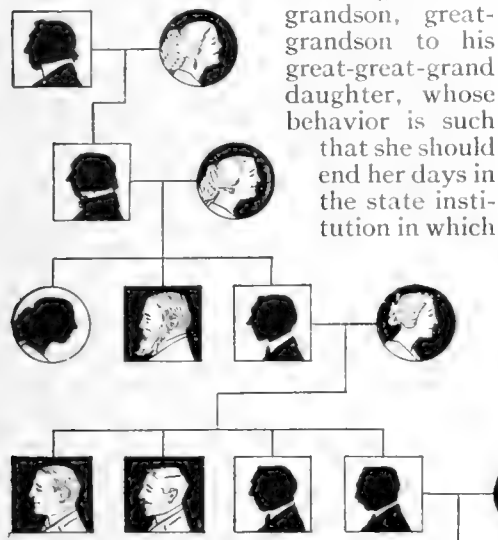

Chart 1. The black profiles in the circles and squares represent the affected females and males respectively

the law of the inheritance of this trait. The circles represent females and the squares males. The black profiles in the circles and squares represent the affected females and males respectively. Chart 1 starts with a female—a grandmother who had three bad-tempered children, two sons and one daughter. One son married a bad-tempered woman. Two of his daughters are notoriously ill-natured. One of them is under custodial care.

That the shrewish do not always hark back to female progenitors is well illustrated in Chart 2, which includes five generations. In this chart the first fiery-tempered progenitor of whom we can get record is a great-great-grandfather. He has transmitted tantrums



she is now an inmate.

In addition to the inheritableness of tantrums, these charts demonstrate that bad temper is one of the contributory causes that fill our houses of correction. These institutional cases come almost wholly from the unintelligent. Intelligent and conscientious persons will wish to do everything in their power to control temper. Abstemiousness in food and drink, sufficient sleep and attention to health in general, may avail something. The imminent

outbursts may be counteracted by physical exercise or a prolonged, soothing bath. The internal irritants seem to be destroyed or gotten rid of by these means. Much may be accomplished by establishing the habit, even at great effort, of ignoring irritating situations. When the intellect is too weak to cope with the situation or the temper is so furious as to be beyond treatment, then custodial care is advisable both from the standpoint of the individual and of society.

The Difference Between a Store Thermometer and an Official Thermometer

WHY does a Weather Bureau thermometer show lower temperatures in hot weather than the thermometer at the corner drugstore? When discrepancies exist, they are due chiefly to the fact that the official thermometer is installed in a wooden cage, where it is open to the air but screened from both direct sunshine and the heat reflected from surrounding buildings, etc. Only under such conditions does a thermometer measure accurately the temperature of the air. A thermometer in the sunshine becomes much hotter than the air

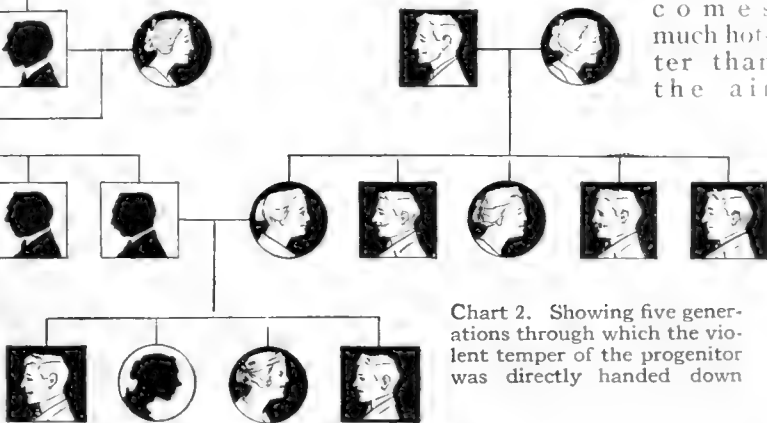
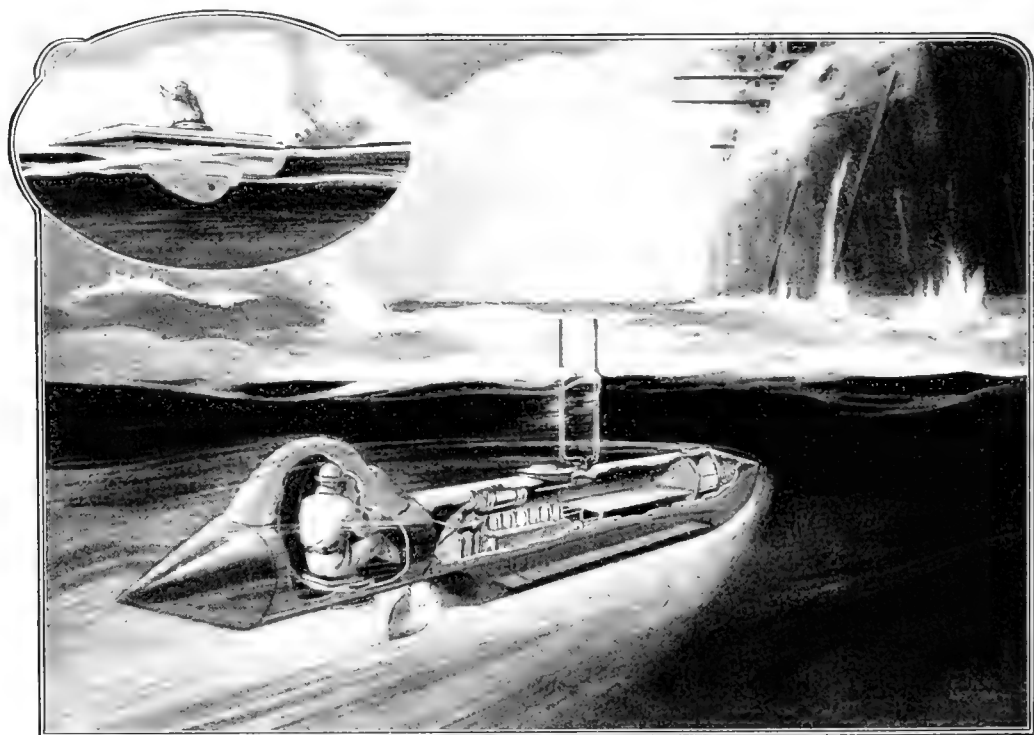

Chart 2. Showing five generations through which the violent temper of the progenitor was directly handed down

around it, and its reading simply tells us how hot the instrument is, not how hot the air is. In large cities the Weather Bureau thermometer is often installed on the roof of a high building, where the temperatures differ somewhat from those prevailing at the street level. The object sought in this arrangement is to obtain a record of the natural temperature of the locality in general, rather than the artificial temperatures of the city.

# A Deadly Man-Steered Torpedo

Would you pilot five hundred pounds of gun-cotton toward a hostile battleship and brave gun-fire?



When the torpedo has been released the weight of the conning tower section causes it to keel over, thus forming a kind of canoe in which the pilot paddles back to his vessel

THE modern Whitehead automobile torpedo is by far the most feared weapon of modern naval warfare. It is, in effect, a little automatic submarine boat, with engines and rudders controlled by a mechanical brain. The soul of the torpedo is the gyroscope—a flywheel spinning at several thousand revolutions per minute. Unfortunately, this flywheel loses speed from the moment of launching. Modern naval battles are fought at ranges of five to ten miles. The Whitehead torpedo is inaccurate at such distances. Indeed, in the whole history of naval warfare the torpedo has reached its target only at short ranges.

Among the plans which have been suggested for increasing the effectiveness of the torpedo, perhaps the most daring

is that of providing it with a real brain and a real controlling hand in the shape of a man. Commander Davis of the United States Navy, designed a little vessel, some years ago, which was to contain a huge explosive charge and which was to be guided by a super-bold mariner against a battleship amid a storm of bullets. That men will volunteer for such hazardous work recent wars have abundantly demonstrated. We have only to remember how the *Merrimac* was sunk in the mouth of Santiago harbor, during the Spanish-American war, in the effort to imprison the Spanish ships believed to lie within. Dozens of men volunteered to block the channel under the fire of Spanish guns.

Hence, when Jacob S. Walch, of Walla Walla, Washington, suggests a torpedo

controlled by a pilot carried along on its flight, we can well believe that he has not underestimated human courage.

He builds his torpedo so that the part in which the pilot sits may be detached after the explosive charge has been released to proceed under its own automatic control.

The detachable, pilot-carrying portion is attached to the main body of the torpedo and the various levers and controlling devices are all within the reach of the operator. When the torpedo is traveling on the surface of the water, partly submerged, the compressed air used by the engine may be taken from an air-chamber, which is in communication with the atmosphere, through vertical tubes resembling periscopes. When the torpedo is to be submerged to a greater depth the tubes are lowered and the engine is then supplied with gas from a compressed-gas tank. The depth of submergence may be regulated by the inclination of planes at the side of the body.

When the torpedo has been brought to proper striking distance by the pilot, who has meanwhile fixed the control for the correct course and the proper submergence, a rod is operated which causes pressure from the compressed air tank to separate the torpedo body from the pilot section. As soon as the pilot section is free from the main body of the torpedo, the weight of the conning-tower portion causes the section to turn over, the top now acting as a keel. After opening the hatch-way, the pilot maneuvers his way back to his vessel.

### The Air-Glider Which a German Boy Is Building

WHILE his father and big brothers are away fighting for the Kaiser, the German boy is taking a renewed interest in aeronautics. The accompanying photograph shows a new one-man aeroplane or glider which contains principles of construction embodied in all the flying machines which are making history these days. The glider is thoroughly typical of our modern aeroplane.

Its perfect rigidity under varying pressures and its never-changing form of wing-surface made possible by the thick, solid middle frame, the deep trussing and the large number of wing-ribs, insure a safe and enjoyable sport for the boy. Although this glider has the appearance of being clumsy and heavy, it is of just the right weight to rise in a light wind and carry the flier a considerable distance.

There is a noticeable contrast between this glider and the Lilienthal models, which are overloaded by the weight of the operator. The latter are much lighter in construction, since the frame is made of willow wands. Professor Langley told in 1896 how attempts to fly his models were frustrated by an uncontrollable "steering" action of wings that were imperceptibly changing shape under pressures. It is interesting to note that the Wright brothers, pioneers of aviation, first learned the rudiments of flying by using gliders of their own construction.

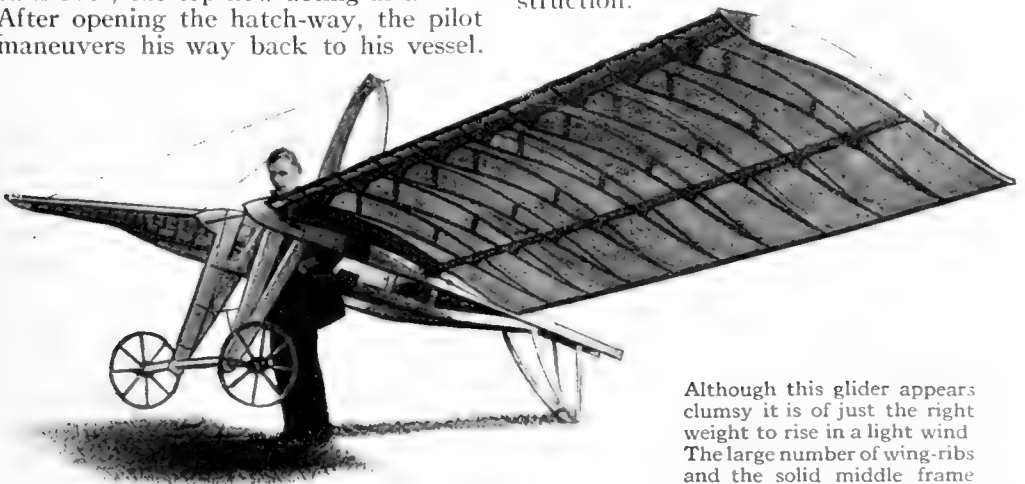

Although this glider appears clumsy it is of just the right weight to rise in a light wind. The large number of wing-ribs and the solid middle frame insure the safety of the flier.

# Using the X-Ray on Animals

A laboratory for finding out what ails injured horses, cows, cats, dogs, and birds

**W**HILE medical annals have been recording the marvelous work of the X-Ray in saving human life, and volumes have been written of the work of the great experimenters, a New York doctor has been carrying this saving light of science into another field—that of our four-footed neighbors.

Dr. Louis Griessman's Veterinary

motor. The horse stands beside the table while it is in a vertical position. He is put in a sling and shackled, and, when all is ready, the table returns to a horizontal position.

Dr. Griessman has invented a means for suspending the X-Ray tube by the use

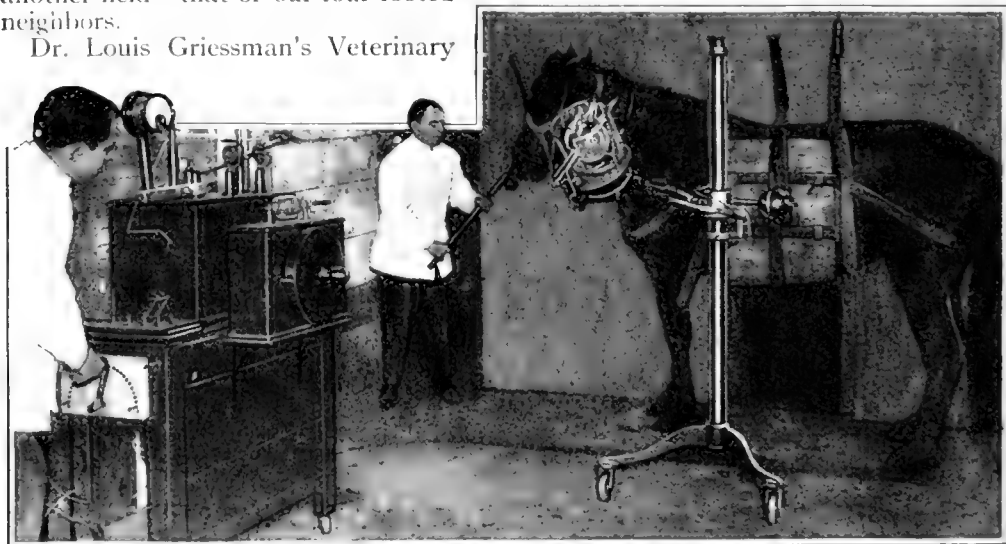

A tilting table operated by an electric motor is used for examining horses and cows. The animal is put in a sling, shackled and bound to the up-tilted table

Hospital and X-Ray Laboratory, for the treatment of horses, dogs, cats, birds, and all kinds of pets, is the only one, so far as known, in the world. Certain experimental work along this line has been done in the University of Colorado, but Dr. Griessman is the only man to organize an institution for carrying on practical work.

He has personally diagnosed under the X-Ray hundreds of cases of bone diseases, fractures, dislocations, heart enlargements and tubercular conditions, of various tissues and organs. His subjects have been horses, dogs, cows, cats, chickens, canaries and monkeys. His laboratories are equipped for handling all kinds of animals.

For horses and cows he has constructed a tilting table operated by an electric

of pulleys and wires so that it can be conveniently swung to any point. Innumerable difficulties encountered in handling the service in Dr. Griessman's Hospital were overcome by Mr. Frank V. McGirr, a young electrical engineer.

## Coal-Mine Fatalities in the United States During 1915

**T**HERE has been a gratifying decrease in the number of fatalities occurring in coal mines in the United States during 1915. The number reported during the year was 2,264, as compared with 2,454 in 1914, and 2,785 in 1913. The actual number killed during 1915 was the lowest for any year since 1906, when there were 2,138 fatalities.

**A Simple Instrument Which Measures the Height of a Tree**

**E**XPERIENCED foresters become expert in judging off-hand the height of average timber. By merely looking at a tree of medium height they are able to make a guess with a degree of accuracy that is sufficient for roughly estimating the number of board feet of lumber it contains. But in the case of timber two hundred feet or more in height even the most expert woodsman is apt to make an error of from ten to twenty feet in his calculations. Errors of this kind greatly impair the value of an estimate of the amount of timber in a tract that perhaps is measured by hundreds of acres.

By the use of the hypsometer, however, the height of the tallest of timber can be ascertained with a remarkable degree of accuracy. There are a number of types of hypsometers, but all of them operate on about the same principle.

One that has been adopted by the Forest Service consists of a round instrument about four or five inches in diameter and an inch in thickness. To one side is attached a convenient handle. Within the instrument there is a device which operates on the principle of a pendulum. Attached to this is a celluloid scale. On the outer edge of the instrument is a small peep-hole on one side and opposite it a square window-like opening somewhat larger in size. There is a convenient device for securing the pendulum at a fixed position.

To ascertain the height of a tree by means of the hypsometer, the operator takes a sight at the proper point on its trunk by looking through the peep-hole and out through the opening on the opposite side of the instrument. Three different heights figure in timber calculations. One is called the merchantable length. In making



The height of a tree can be accurately measured by looking through a slot. The figures are noted on a celluloid scale as on the left

certain estimates the "clear" length is ascertained, while in other instances consideration is given only to the height from the ground to the first limb of appreciable size.

The height of the tree governs the angle at which the operator holds the hypsometer in taking the sight.

**In His Merry "Dogmobile." How a Cripple Gets Along in the World**

**A**LTHOUGH he is a cripple, R. A. Burdick of Los Angeles, has traveled nearly five thousand miles in a single year with the aid of his pet dog Trix. The dog is harnessed to a specially built tricycle equipped with handle-bars, headlight, tail-light and a seat similar to that used on wheel-chairs.



The dog is harnessed to a specially constructed and equipped tricycle-wheel chair

He sells newspapers and chewing gum. When he wishes to stop he presses a leather pad to the wheel, and the dog stops immediately.

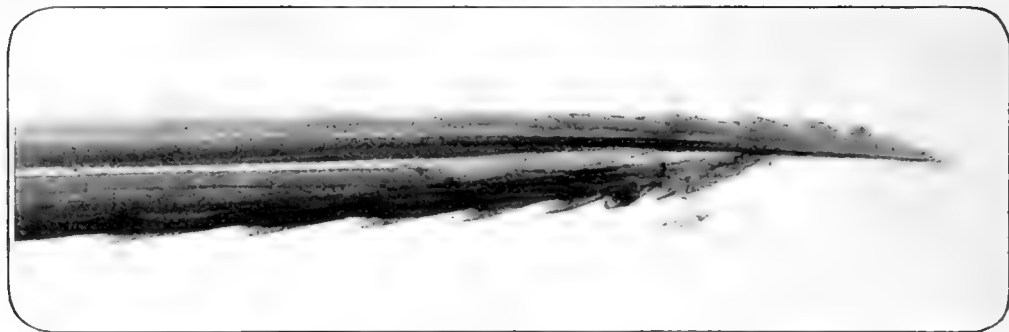

The bee's stinging apparatus as shown up by the microscope. It consists of a sheath within which move two barbed lancets. These form a hollow tube for the poison

## The Honeybee's Infernal Machine

**I**N proportion to its size, the sting of the honeybee is probably the most effective infernal machine in existence. The stinging apparatus is smaller than that of a rattlesnake, yet a single sting has been known to kill a man. When we realize that it is almost invisible, and consider what it can do, we cannot fail to be astounded. It seems the very quintessence of devilishness.

The honeybee's sting is complicated — so complicated that many words and much ink have been used in discussing its construction and use. It is generally conceded that the sting consists of a shaft of three parts, the principal one being a sheath within which move two barbed lancets. Like the barbs of a fish-hook, the lancets are not easily extracted from the flesh into which they have been driven. The sheath and the lancets combined form a hollow tube through which the poison flows from the poison-sac. Two hairy, soft projections, evidently very sensitive, inform the bee when she is in contact with a stingable object.

A snake's fangs are harmless when removed from the snake. Not so the bee's sting. Man, with all his ingenuity, has not yet devised a machine or a thrower of poison gas that will continue to act after the soldier is dead, but nature has done something like it in the honeybee.

At one time it was supposed that the poison that accompanies the sting is formic acid. That is now doubted, although the material has an acid reaction. It is a curious fact that there are other

poison glands in the bee that are alkaline. A well-known investigator asserts that the secretion of both sets of glands must be mixed to be fully effective. The secretions enter the barbs. Here the two are mixed, later to be forced out of the channel formed by the sheath and lancets and through certain openings in the lancets. Both the channel in question and the openings were formerly supposed to be merely passages for the poison. It has been shown by a skilful investigator that the channels in the lancets are not connected with the poison duct, and that they are smelling organs, used probably in gathering the nectar for the making of honey.

There is a long list of remedies for the honeybee's sting, all of them worthless. Rubbing or even touching the injured spot does positive harm, because the friction or the pressure forces the poison into the circulation and may intensify pain which would otherwise be only trifling. A well-known authority says, "There is no remedy in the world like letting an ordinary sting alone and going on with the work without even thinking about it."

At times, with no apparent provocation, honeybees will sting a horse or a cow to death within a few minutes; at others they may be thrown around and handled roughly with no more danger than if they were flies. I have shaken the contents of a hive over the bare arms and necks of young ladies without the slightest injury to any one. Again, one may only walk by a hive and be stung.



**Here It Is: The New Shaving Harness That Carries Brush, Mug, and Mirror**

**A**NOTHER device has been invented to reduce man's misery as he writhes under the razor. This time it is a shaving-harness. The mirror, shaving-brush and shaving-cup are all attached to the harness in positions convenient to the hand. Armed with this equipment a three days' growth of beard can be attacked with absolute certainty that the task will be completed without the usual contortions of the head and neck.

The frame which holds the mirror is carried on lazy tongs and is hooked over the shoulders. The lazy tongs have a sliding mounting so that the mirror can be moved out or in as far as desired. Furthermore, the mirror swings on a pivot to any convenient angle.

Holder are provided for the brush and shaving-cup. The brush is a little beyond the mirror, and the cup-holder is attached to the frame where it fits against the body. Evidently the inventor, Vicente Aldrete, of Philadelphia, has not considered the use of shaving-sticks and powdered soap. It would be possible, however, to make the cup-holding ring small enough to fit a shaving-stick. The harness is collapsible and can be neatly folded away.



The frame, holding the mirror, mug and brush, is hooked loosely over the shoulders



With this lock, an automobile robe, raincoat or other article can be safely left in the car

**When You Leave the Automobile, Lock the Robes!**

**A**THIEF finds little difficulty in removing the robes from automobiles left standing unoccupied at the curb. But a lock has now been invented which is designed to clamp the robe so securely that it can not be removed from the rod over which it is hung without cutting the robe or otherwise damaging it so that it loses all value as a merchantable article for the thief. Raincoats and other articles may be secured in the same way.

The lock is operated by a combination, so that there is no key to be lost. The only essential is a clear head to remember the combination. When not in use the lock is left clamped over the rod where it is not a disfigurement, being of neat-looking nickel-plated steel construction three-quarters of an inch high and two and one-quarter inches wide when closed. Several of them might be kept in the automobile ready for use when needed, to insure the safety of the robes or other articles left there.

The lock will also be found convenient for holding the robes and coats out of the way and for preventing them from slipping to the floor when they are not required for use. With a little ingenuity they may be made to hold any number of shopping parcels.

# Is the Automobile Inventor Earning His

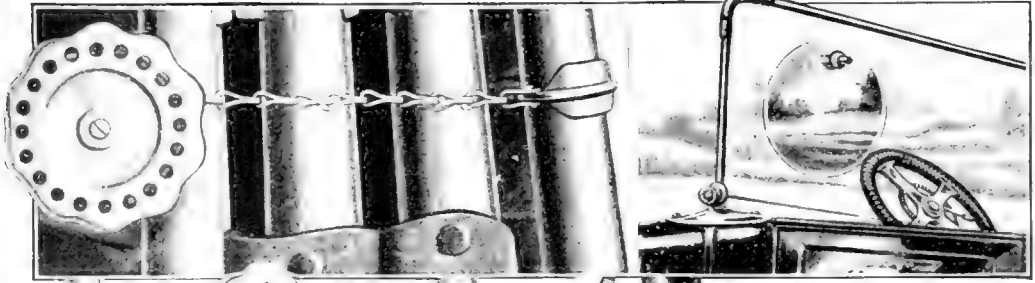

Above: A flexible disk of deep orange attached to the windshield by a vacuum cup prevents eye-strain

At left: Steering-wheel clock encased in rubber, making it vibration-proof, shock-proof and dust-proof

Above: A chain used as an automobile top holder. It can be adjusted to a sixteenth of an inch and it eliminates projecting arms and unattractive straps

At right: A combination wrought-steel basket and luggage-carrier which slips over the hood. It is rigidly fastened to the frame and to the dashboard

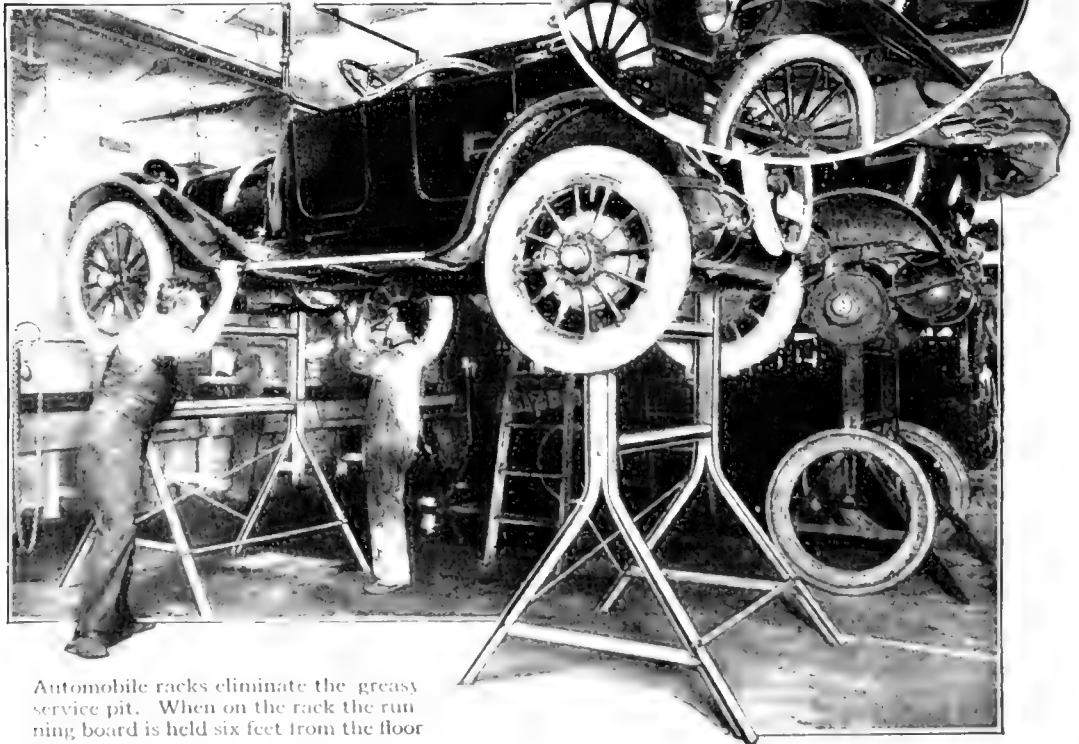
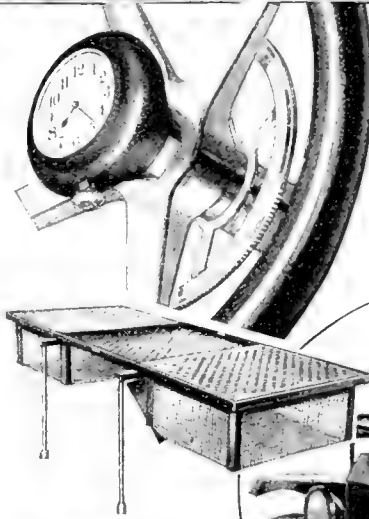

Automobile racks eliminate the greasy service pit. When on the rack the running board is held six feet from the floor

# Salt These Days? Here Is the Answer in Pictures

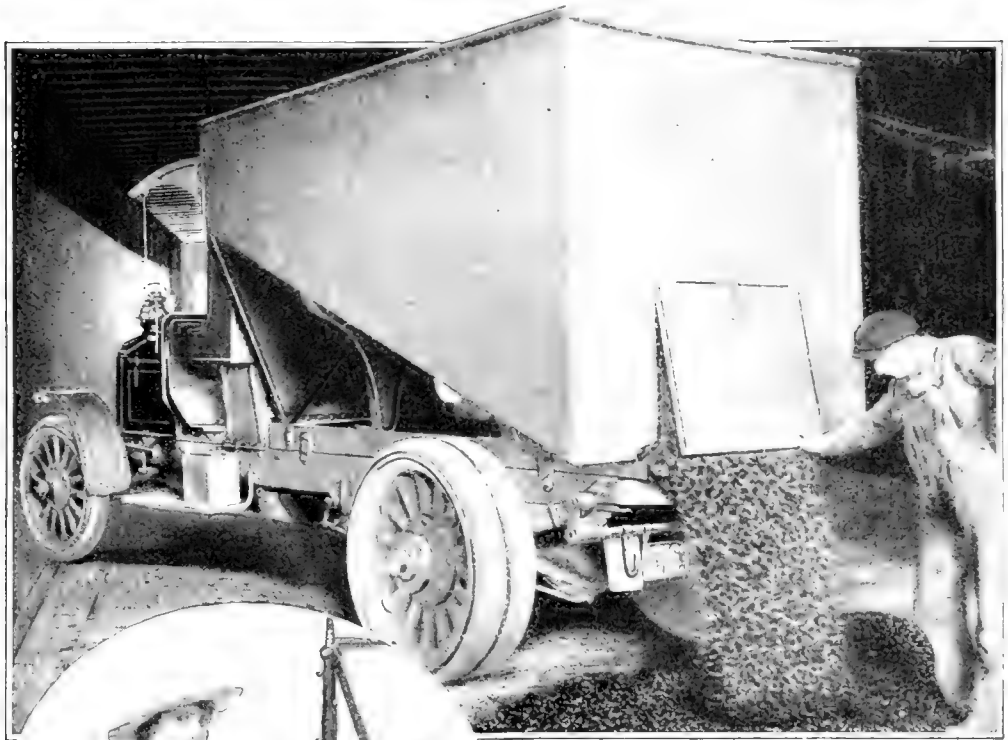

A slanting floor and small rear door enables a motor-truck to drop coal into ferry boat bunkers

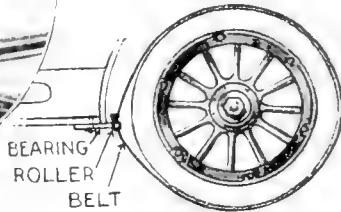

At left: A non-skid belt replaces the tire chain. It encircles the tire and travels over a roller on the running board

Above: A miniature folding top for the baby automobilist. It tucks him in safely

Below: Spraying sand on slippery streets. The sand is spread by a rotating disk

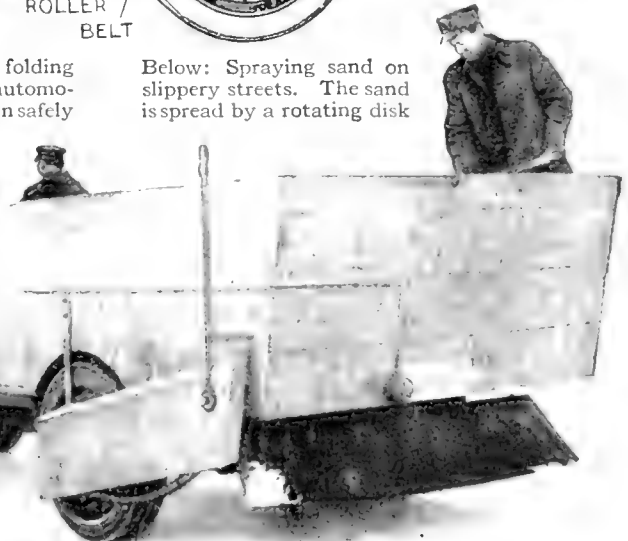
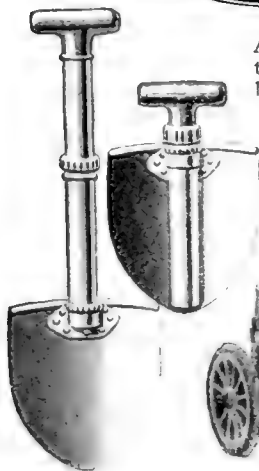

A shovel with a telescoping handle. It is small enough for the tool kit

# New Accessories for the Motor Car and Sturdy



Above: Twelve-ton trees are carried on truck and trailer in Washington. One truck can move about forty-two thousand feet of lumber a day

At left: A demountable wheel-set for Ford cars, consisting of special steel plates attached to the inside of each of the wheels

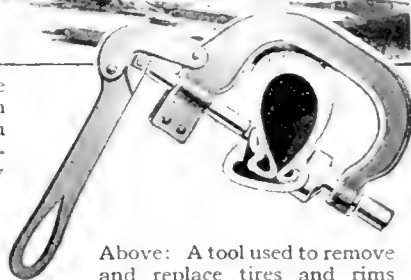

Above: A tool used to remove and replace tires and rims

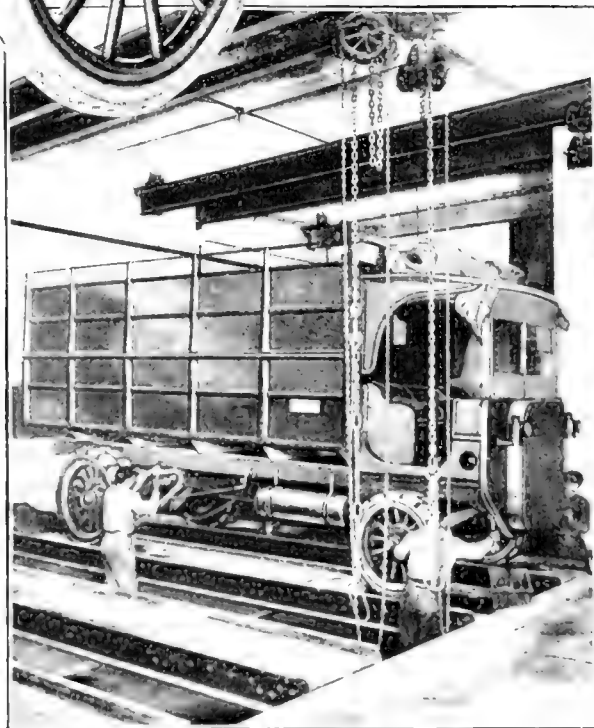
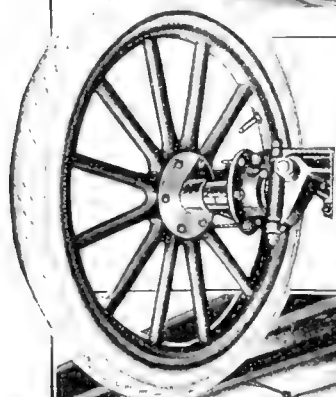

Above: A sidecar hood and windshield made of transparent material. A speaking trumpet facilitates communication with the driver of the car



At left: A sunken floor enables workmen to disconnect motor-trucks and fit or repair the springs while standing upright. Heavy steel bridges support the trucks

# Truck Which Are Making Them More Versatile

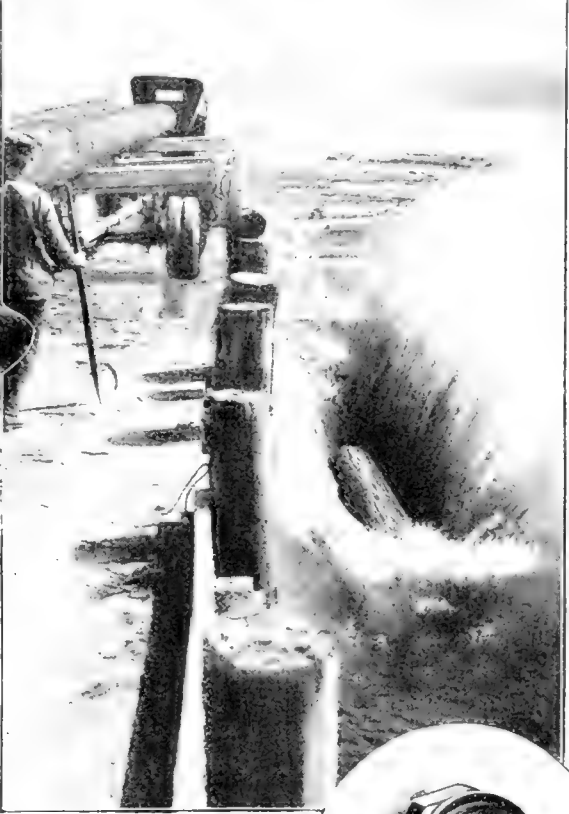
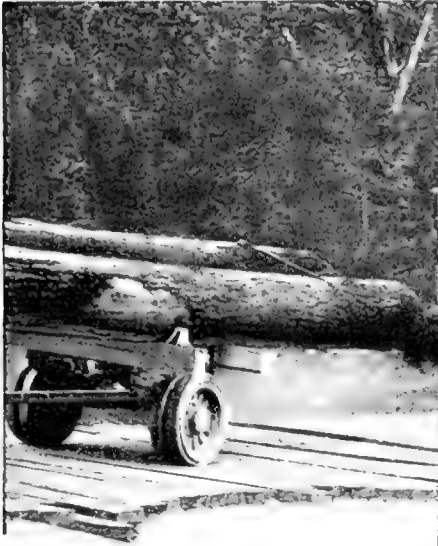

At right: Unloading logs from a truck over a wooden pier into Lake Sammamish, Washington

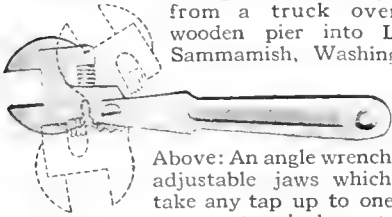

Above: An angle wrench with adjustable jaws which will take any tap up to one and one-quarter inches at any one of eight different angles



A spark-plug with a turbine fan rotated by the engine explosions. Hot sparks are delivered to the bushing, giving a larger sparking area and throwing off waste oil deposits

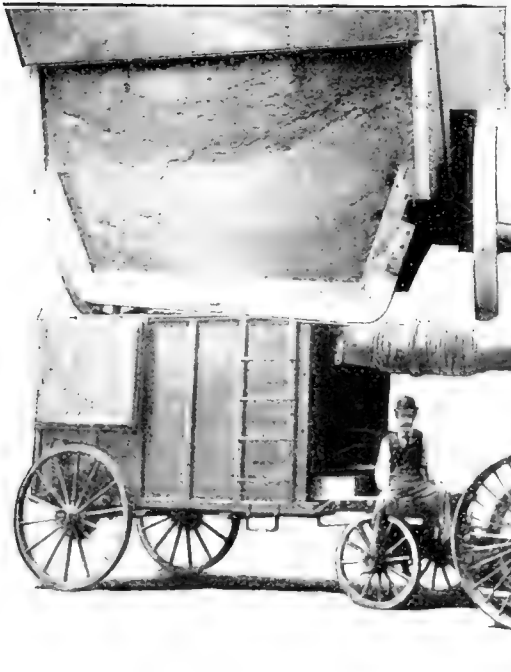

A gas-electric suction street-sweeper. The dirt is picked up by a revolving brush and sucked into a pipe where a blower sends it to the trailer. There it is screened and packed for removal

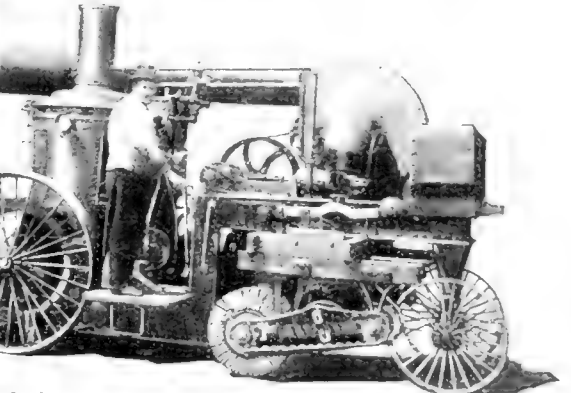

# Patrolling Eight Miles of Fence

How hunters and hounds protected a flock of sheep and how a new type of fence was built to keep out coyotes

**T**O prevent wolves, coyotes, and other wild animals from entering a pasture where experiments in sheep-raising were being conducted, hunters employed by the Forest Service were required to patrol eight miles of fence twice a day in the Wallowa National Forest, in Oregon.

Two thousand five hundred and sixty acres of choice land were enclosed to conduct experiments with a view to ascertaining whether it was more advantageous to care for sheep in pastures

than to herd them on the open range. A coyote-proof fence eight miles in length enclosed the pasture. It was made of woven wire about four feet high, with two strands of barbed wire across the top.

The large flock of sheep within the enclosure attracted many wild animals and it was not long before they burrowed under the fence and set upon their prey.

Accordingly, the Forest Service had experienced hunters accompanied by hounds patrol the entire length of fence twice a day for four years. But the sheep were still preyed upon until hundreds of coyotes and wolves had been killed.

The erection of the fence over rocky stretches of ground proved a troublesome problem, because the Forest Service did not want to go to the expense of drilling post holes. The difficulty was overcome by supporting the posts with "jacks" consisting of piles of rock holding in position props which were nailed to the posts. The "jacks" were set up on the inside of the pasture. The depth of the post holes that were dug before rock was encountered governed the height of the pile.

Patrolling eight miles of fence twice a day for four years to prevent wild animals from entering a pasture where experiments in sheep-raising were being conducted, was the tedious task of the Forest Service hunters

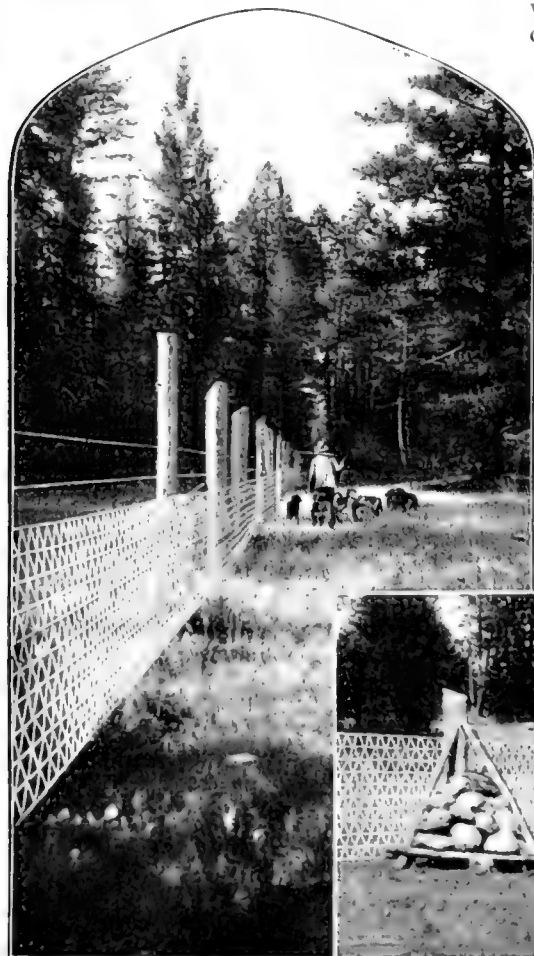

Instead of digging holes for the posts over stretches of rocky ground, where the expense of drilling would have been greater than the Forest Service was willing to incur, large stones were piled up to hold in position props to which the posts supporting the wire were nailed



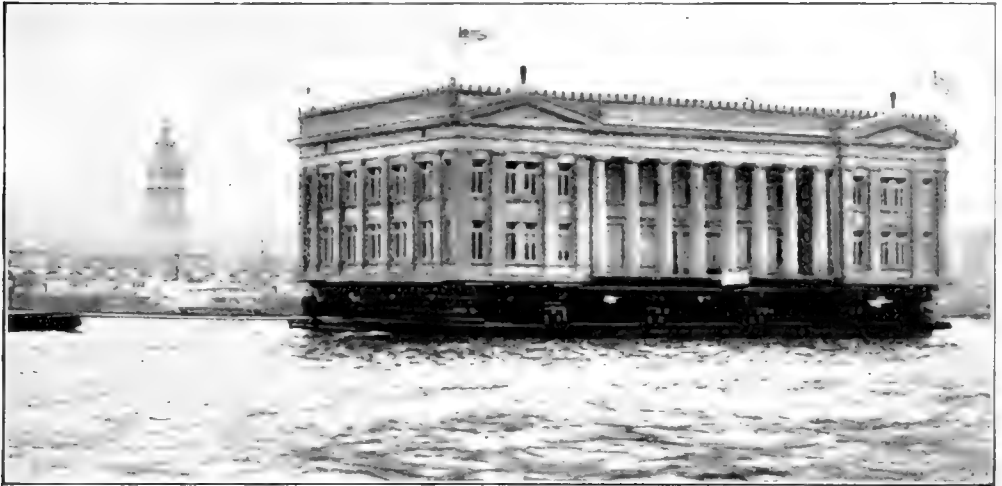

The spectacle of this one thousand-ton Exposition building floating serenely down San Francisco Bay caused residents of the Coast to doubt the testimony of their own eyes

“Bon Voyage” to the Ohio State Building!

THAT all of the splendid architectural masterpieces which made of the Panama Exposition grounds a veritable fairyland were not doomed to inglorious destruction after their short span of life is evidenced by our photograph, in which the Ohio State Building is seen taking a leisurely and dignified trip down San Francisco Bay.

The building, which weighs more than a thousand tons and which was a conspicuous feature of the Exposition, was purchased by a Country Club patronized by the elite society of San Carlos, California. Arrangements for its transportation down the bay began with the hiring of a number of barges which were lashed together to form a raft on which the building was mounted. It was towed by tugs to San Carlos, a distance of twenty-three miles.

To Protect the Fingers of the Woodworker

THERE is probably no badge which designates the woodworker or cabinetmaker so surely as the mutilated fingers which most of them carry. So intent does the worker become on the task of getting and keeping his accurate measurements for the cutting process that the danger to his fingers is forgotten until too late. But the fingers of the woodworker cannot come into accidental contact with the blade of the vertical cutter-head of his woodworking machine if the machine is equipped with the new safety-guard illustrated. This guard is of cylindrical form, consisting of spaced rods extending between two rings, the upper of which is in engagement with a sleeve which is telescopically and adjustably mounted

on a cylinder. The cylinder is suspended from the free end of an arm which is connected with a supporting standard. This construction admits of raising the protecting cage or guard and adjusting the cutter-blades.

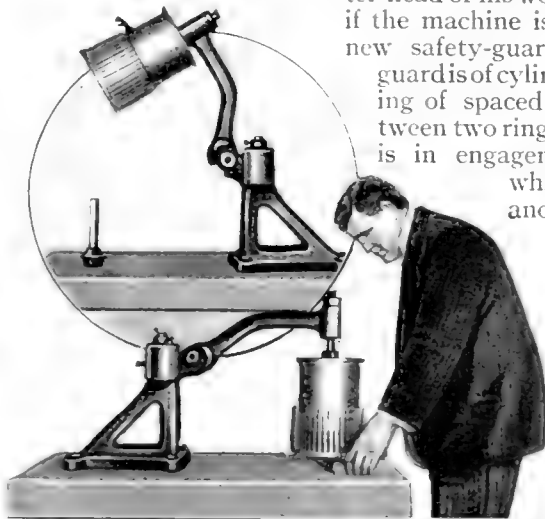

The guard consists of a cylinder suspended from the end of an arm connected with a stationary supporting standard



# Protecting the Telephone Operator

How the loud-speaking telephone eliminates danger from high-tension currents



The apparatus reproduces the exact tones of the speaker's voice but with magnified volume and clearness, so that a whisper would be distinctly audible under ordinary conditions

**E**LECTRIC traction and power companies usually have their telephone lines on the same poles with high-tension feeder and transmitter-conductors. As a result, telephone users may be exposed to danger. The high-tension lines may cross or touch telephone lines, or the induced current in the telephone lines, due to their being parallel to the high-tension line, may be sufficiently great to place the telephone operator in imminent danger.

For providing the required protection under the above conditions, the loud-speaking telephone has been invented. The person using the telephone does not come in actual contact with it.

The apparatus illustrated reproduces

the voice as spoken into the transmitter with a volume somewhat greater than the speaker's and with perfect clearness. If under ordinary conditions a conversation in a room fifteen feet square can be understood, the speaker would not raise his voice above the usual pitch. In operating the apparatus the conversational tone is reproduced with about the same volume and clearness. The speaker's natural voice is said to be easier to recognize than in the usual type of telephone.

Instead of lifting the receiver off the hook, the method adopted with the ordinary telephone, the operator presses a lever with his foot to call "central."

Protecting the Ears from the Shock of Great Guns

SPECIALISTS on nervous disorders

Tell us that the noises of concussions, trains, fog horns, gun reports, the clash of machinery and other harsh or prolonged sounds wear away the energy of the nervous system, shock by shock, causing headaches, deafness, fatigue and debility. An ear-protector, then, designed to modify the sound vibrations before they can be communicated to the organs of the internal ear, would seem to be a very necessary thing in some walks of life.

One which has been placed on the market recently is made of transparent material and has two soft rubber disks. One of these disks is small and thin and fits into the canal of the ear adjusting itself to any size ear. The other disk is larger and thicker and covers the orifice of the canal, preventing the protector from going in too far.

The device is a guard, not a stopper, and does not interfere with the natural circulation of air in the canal of the ear. The atmospheric pressure is kept normal and sounds of moderate force enter the ear without change. Only those sounds

which are of sufficient strength or of such character as to produce shock are modified. The protector is also useful in keeping the ears free from dust and for excluding wind and water.

There are several of the ear-protectors and shock absorbers on the market. The demand for them has been increased by the war, so many of the soldiers having been deafened from the noise of explosions and bursting shells. Wherever there is a special demand for any article there are always special efforts to improve on the existing models so that a person may take his choice of almost any

number of kinds. The type which has been adopted recently by the British Admiralty for use in the Navy is shown in the photograph at the bottom of the page. The neat little box holds a pair of shock-absorbers and fits into the vest pocket as easily as a pill-box. The principle involved is the same as in the first illustration. There are two sound-stops, one in front and the other in back of a sensitive diaphragm. These effectually prevent any violent shock from passing on to the inner ear. The stops and the diaphragm are held in place by washers. The device can neither go in too far nor drop out of the ears accidentally.

It has been found that soldiers using these ear-protectors are stronger physically and less inclined to suffer from digestive disorders on account of the better condition of the nervous system. Residents of rural districts visiting in one of our modern cities, and even the long-suffering city-dweller accustomed to the noise might also value the shock-absorbers.

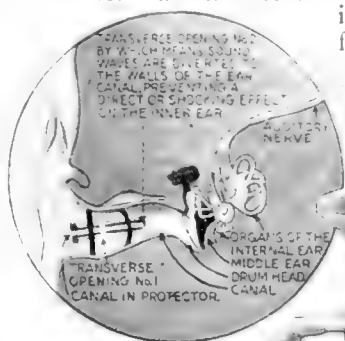

The device is a guard, not a stopper, and does not interfere with the circulation of air in the canal of the ear

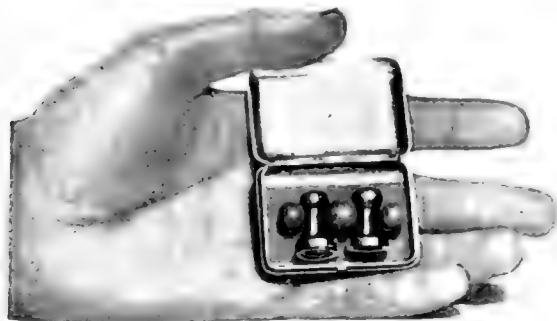

The type of ear-protector which has been adopted by the British Admiralty for use in the Navy

# Improving the Imperfect Hen

Ingenious man, after considering the hen,  
reduces her to a mere egg-laying machine

By George Wörts

IF occasional assaults upon the patent office by ingenious, inventive gentlemen from all parts of this country are to be taken seriously, Mother Nature made some silly mistakes when she devised and constructed the *gallus domesticus*, otherwise known as the barnyard fowl.

When Nature provided the hen with two legs, a head, feathers and a mysterious internal mechanism which disgorges an egg on occasion, she left the poor thing with a woefully incomplete equipment for living the barnyard life. In view of Nature's negligence, brains mightier than the hen's now buzz

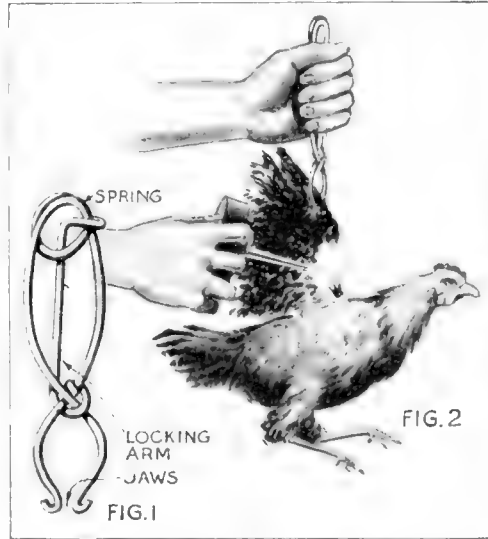

A hen handle. With it, the fowl may be effectually powdered. The wing-clip clamps the members securely while the germicide is being applied liberally

through the long days, conceiving apparatus, mechanisms and "devices"—mostly "devices"—for making the imperfect *gallus domesticus* live a blamelessly chaste and worthwhile existence.

If the learned opinions of poultry improvers could be combined into a barnyard creed which the hen could study at her leisure, and if it were printed legibly and tacked up conspicuously within and without the hen roost, then the hen might

raise herself in the estimation of those who consider her imperfect. Why not, indeed? The suggestion is offered freely to the entire poultry universe. Why not



An inspection of the rooster's beak will reveal the reason for his apparent penitence. Inventive man has muzzled the rooster. The reason being that he (the rooster) occasionally plucked beakfuls of feathers from the wings of his wives

The ghost-like figure of a hen seen soaring over the hen-house mirrors the thoughts and desires of the hen in the foreground. Her wing is clamped to her side by means of a capable wire clip. She cannot fly; she can only dream of flying

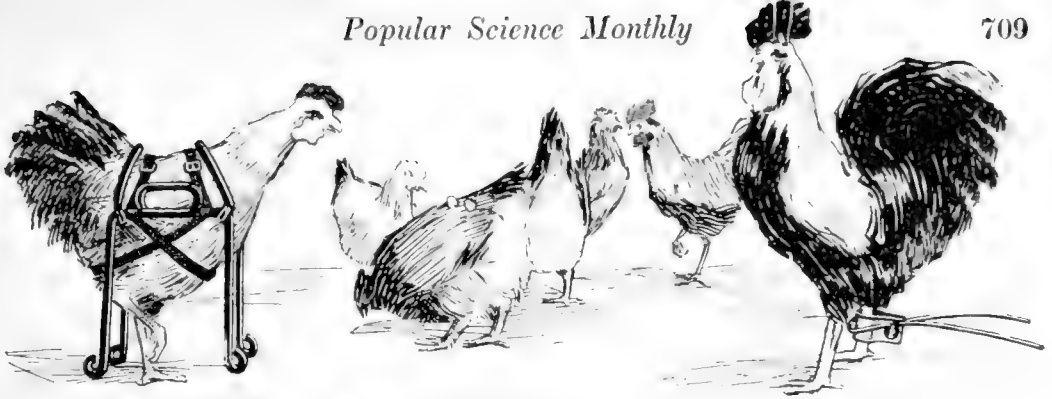

The hen at the left has not been harnessed with the end in view of giving the children a ride. She has submitted to the indignity of a "setting preventer." When she attempts to climb into a nest and settle down, the imagination of the reader can supply her subsequent astonishment and chagrin. Will the rooster at the right scratch up the new garden? Not after he tries it with this leg attachment designed to prevent just that performance

have a creed, or a set of poultry commandments struck off from the press and distributed gratis, or at small cost, so that the *gallus domesticus* could memorize them, and cultivate her mind?

Differences of opinion might arise regarding the necessary content of this creed; but after thoughtful examination of the available material secured from the Patent Office, the following resolutions which encompass all the important points have been drawn up:

"I will not set when my master denies me that pleasure; neither will I fly maliciously out of the confines which my master has provided for me; I will render a correctly audited account of the number of eggs laid by my humble self in the week; and all of these eggs shall bear my personal trademark; I will lie in a posture according to the will of my merciful master, awaiting sacrifice, moving neither head nor tail feather; never will I scratch up the gardens which the Lord seemingly provideth not for me; ever will I tread in the paths wired off for me, bringing forth the young of my species whenever it is demanded of me, and sitting uncomplainingly upon glass eggs, door-knobs and other objects

which my master kindly provides for me. Yea, verily, I will walk in the cow-paths of glory, looking neither to my right nor to my left, nor winking any eye-lid, thus that my sacred name shall be saved from the unutterable disgrace into which it has been dragged by my unfeathered sisters in the great, ungodly cities."

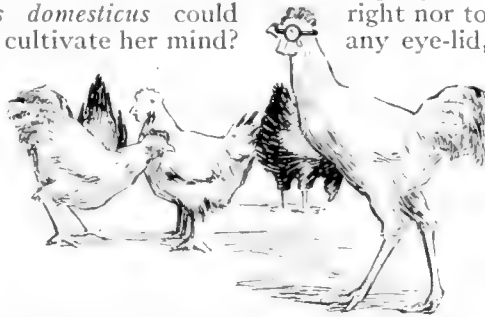

This rooster is not attending a poultry school, despite the evidence to the contrary, which the goggles create. A thoughtful inventor has simply provided him with a protection for his eyes. It can be seen that the rooster appreciates this courtesy highly. Strangely, the lady hen to the left seems on the point of fainting at sight of her husband's odd appearance

name shall be saved from the unutterable disgrace into which it has been dragged by my unfeathered sisters in the great, ungodly cities."

One of the heartiest laughs we have ever wrung from a joke-book was recently unearthed from what is occasionally the greatest of all joke-books—the Patent Office Gazette. The joke in

point had to do with an enterprising apparatus devised to prevent the hen ambitious to set from realizing her ambitions. It comprised a dozen eggs all of which were connected together by means of short lengths



When the chicken is caught its legs are clamped, making it helpless and passive

of rubber tubing through which ice-cold water from a tank suspended from the top of the henhouse was run to the eggs. When the mothering instinct became too great for a hen to resist she would mount these joke-eggs. When her warm breast came in contact with the frigid eggs, she would leap off with a cackle of anguish, and thereafter be cured of the setting habit.

Was it not ingenious? Indeed it was.

A contraption devised for the same purpose and also unearthed from the scintillating pages of the Patent Office Gazette is displayed pictorially in these pages. It has a devilish ingenuity all unto itself. Look at this picture in which a hen may be observed leaping angrily from a nest of spikes. This pointed warning to the hen who aches to set, belongs to the same category as the machines

brought out for purposes of inflicting slow torture at the time of the Spanish Inquisition. Some prehistoric fragment of barbarism in all of us makes a device of this sort unusually interesting. Unquestionably, if this invention were installed in a barnyard, the farmer-owner could charge ten cents admission, and the public would get a generous ten cents' worth in watching fowl agony. Can you put your own soul through the misery to which the would-be-mother hen, with the delicacy which that feeling is supposed to bring, submits herself when

she settles calmly down, with every honorable intention, upon a nest of naked, brutal spikes?

The hen-house-of-horrors, if properly furnished with these machines of malice, would not satisfy itself merely with ice-cold eggs and spiked nests. Other inventions, if they were attached, would transform the peaceful hen into a picturesque spectacle, a cross

between a taxicab and an infernal machine. In fact, if the hen were properly equipped with all the "useful devices" which man has thoughtfully and modestly provided, she would not only be bound, gagged, fettered, spiked and frozen; but her vision would be guided by goggles; she would stamp each egg as it was laid with a trade-mark.

Altogether she would bear so much mechanical miscellany upon her innocent young should-

ers that she could neither sit in the forbidden nest, run amuck in the forbidden garden, fly into the forbidden air, nor, indeed, could she lay the luscious egg, nor hatch the necessary and succulent young springling.

Human sympathy with the helpless unfortunates would prompt one to say, "Let the poor creatures alone!" Nevertheless, the farmer may see in the numerous inventions mentioned helpful means of augmenting and protecting his egg supply, and if so, humanitarians have no right to hinder him from employing them.

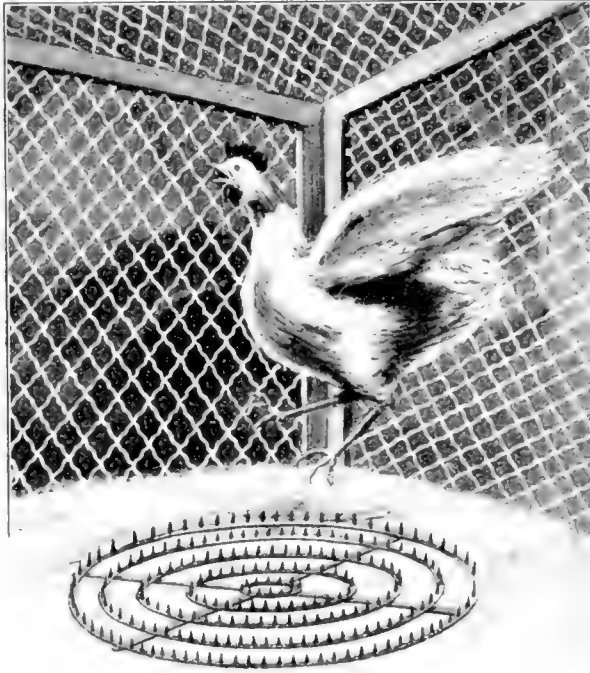

When the would-be-mother hen approaches this nest she is received by an array of sprouting spikes. The man who conceived the idea probably derived it from a volume upon the Spanish Inquisition. It is indeed most effective. The hen squats upon the spurs; and she arises with cackles of wrath, cured of her desire to set

# Telegraphing Through the Ocean

So that ships may avoid one another in a fog, Christian Berger converts them into huge violins which send out sound-wave signals

THE small-town American boy has a noise-making toy, which for simplicity, cheapness, and, above all, effectiveness, can hardly be surpassed. The principal components of the contrivance are: one tomato-can, one string, one lump of resin, and plenty of muscle in the small boy's right forearm.

Into a hole in the bottom of the tomato-can the string is run, a lumpy knot on its inner end preventing it from slipping completely through. This leaves a long, dangling cord when the ex-tomato-container is held outward in the boy's left hand. With his right he grasps the lump of resin and commences to stroke the string.

A responsive "ee-ee-eek" emerges from the mouth of the can at the beginning of the stroking process. Shrieks, cat-calls and strident, earsplitting wails can be made to follow the "ee-ee-eek."

In a sense the contrivance is not unlike a violin. The can is a resonator; so is the violin body. The string is rubbed to make a sound; so is the catgut of a violin. The fundamental principle involved is the same.

Curiously enough, a contrivance operating very much on the same principle has been found to be one of the most effective submarine signaling devices yet brought out. The machine in

question is the invention of Mr. H. Christian Berger, a New York physicist. It has been put in successful service on

a number of American vessels, some of them warships—despite its resemblance in principle to the tomato-can toy or the violin. It is the result that counts.

Mr. Berger's device employs either a narrow steel strip or else a piano wire as the vibrating member, this serving the same purpose as the string in the case of the can-toy or violin. One end of

the wire is attached to a plate in the steel hull of a vessel, the other end being fastened to a similar plate on the opposite side, or else terminating in a framework affixed to a convenient beam. The steel plate in the side of the vessel acts as a sounding-board to send sound-waves out into the water, just as the bottom

of the tin can sends waves into the air. Instead of a lump of resin in the hands of a small boy as the exciting agency for the vibrating strip, this contrivance employs a motor-driven rubbing-wheel, the felt-covered rim of which is the equivalent of a violin bow and is moistened with alcohol in order to provide an efficient rubbing medium. Although the motor which drives this wheel runs continuously, the wheel itself

may be started and stopped at will by means of a telegraph-key controlling an electromagnetic clutch mounted on the motor-shaft. Thus a telegraph-key governs the sending of vibrations

just as in wireless telegraphy.

The question naturally arises: Of what use is a submarine signaling

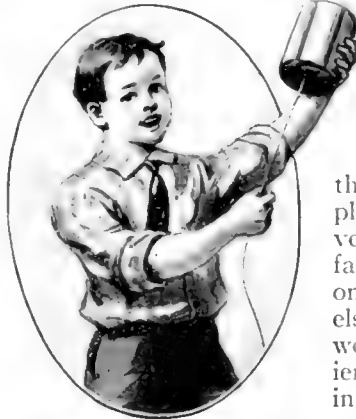

The harder he pulls the more distracting the noise

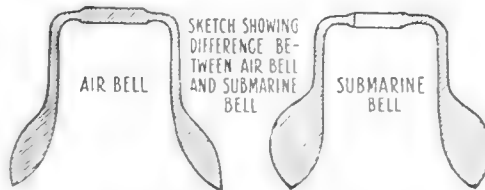

In a few feet under water a bell's sound loses its characteristic bell-like tone

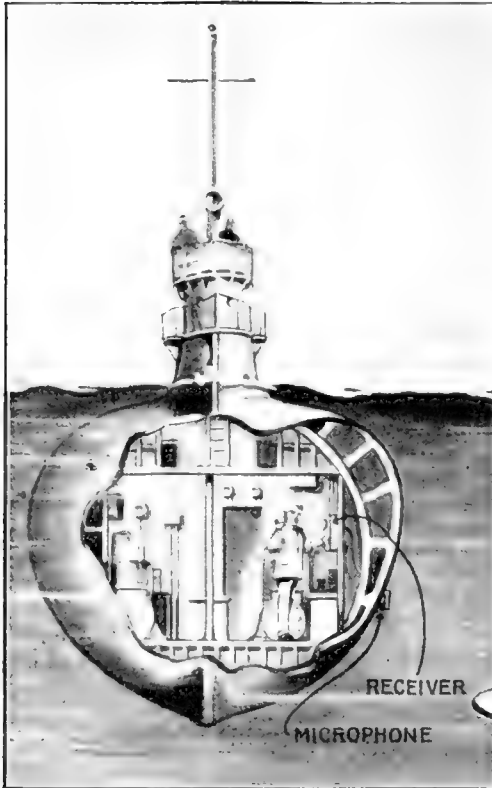

The signals sent out under the water are picked up by a microphone in the vessel

device. Is it not enough that men can signal through air with whistles and lights, through ether with wireless telegraphy, and over wires with the aid of electricity?

The answer is this: Strong as men have built ships, as well as they have chartered the ocean, as many safety devices as they have installed on boats, one overpowering danger still confronts navigators. That danger is fog. In a thick fog it is almost impossible to see from one end of a boat to the other, let alone out over the water toward any approaching vessels. Sound-signals do not carry far in air and are most untrustworthy. Hence the frequent mishaps which occur when bell-buoys, or other sound warnings near hidden reefs are not heard. Signal lights, rockets, lanterns, and similar devices depending upon light are obviously inoperative in a fog. Wireless waves—usually so effective in warnings of sea dangers—have their limitations, too. Unless the op-

*Mr. Berger's device*

Mr. Berger's device resembles in principle the tomato-can toy. On the other hand, sounds sent out into the water

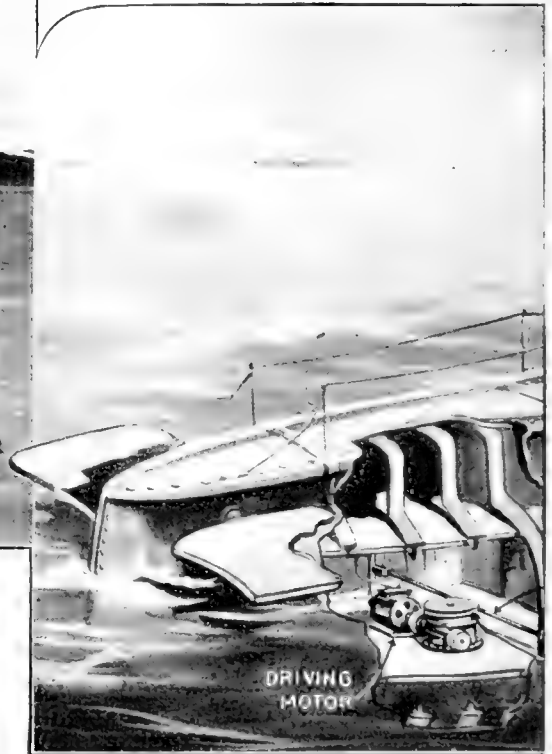

erators carry on specific conversation as to their ships' positions and the danger of bumping into each other or into objects on shore, the wireless signals themselves carry no warning of impending disasters; the strength of wireless signals, as received, is no criterion of the sending vessel's distance.

Hence when a fog descends over the sea, light signals are utterly useless, sound signals in air do not carry far and are uncertain, and wireless telegraphy is good only in certain instances. Is it any wonder that inventors have taken to investigating the possibilities of submarine signaling, all the more since they have discovered that sound-signals will carry long distances under water and are unaffected by fogs and storms?



*Morse code for 'A'*

by it can be made to have any sustained duration desired, so long as the felt-rimmed wheel rubs on the steel strip

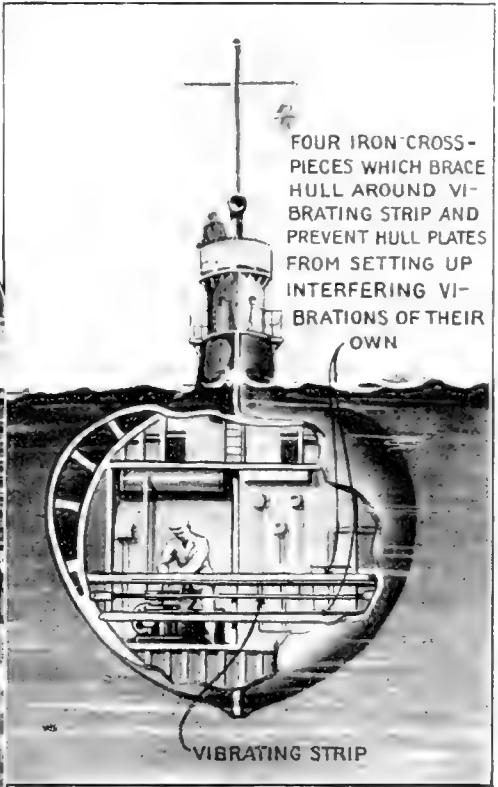

Vibrations from the interior of the ship's hull do not interfere with the signals

It is a queer world, this—down “under the sea.” It might be supposed that no sounds at all can be heard under water. The opposite is true. Sounds carry better in a dense medium like water than in a comparatively “thin” gas such as air. All sorts of sounds can be heard under water—the throb of some distant ship’s propeller, the pounding of engines, the explosion of distant mines, and hundreds of other noises. A microphone, placed in a chamber of water at the side of the receiving vessel and connected with a telephone receiver, aids in this hearing. Singhalese fishermen, however, have for centuries carried on communication between boats by the simple method of striking an earthen bowl under water, the listening fisherman

placing his ear against the bare hull of his boat.

Submarine bells are already in use as fog warnings. Some attempt has been made to adapt them to the sending of Morse telegraph signals between one boat and another, as for instance between a warship and a submarine. The sound from submarine bells, however, does not endure; it is not sustained. In other words, one stroke on a bell sounds to the underwater listener just like any other stroke. All the strokes are short—have no duration. Since all the sounds are “dots,” it is obviously impossible to send Morse signals, dependent on both dots and dashes (short and long sounds). Moreover, seamen who have listened to these underwater bells say that in a few feet a bell’s sound loses its characteristic bell-like tone. The sound simply comes to the ears of the listener as a dull, leaden “click,” something like that produced when two ordinary table-spoons or a knife and fork are struck

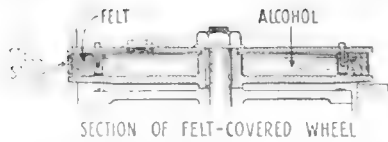

THIS ELECTROMAGNETIC CLUTCH IS FASTENED TO MOTOR SHAFT WHEN MORSE KEY IS DEPRESSED. CLUTCH IS MAGNETIZED (BY THE COILS) AND JERKS THE REVOLVING DISC OVER AGAINST ITS FACE DISC THEREUPON REVOLVING ALONG WITH CLUTCH AND MOTOR, CAUSING THE FELT WHEEL TO TURN AND RUB THE STEEL STRIP, GIVING OFF A RESULTANT SOUND.

THIS ELECTROMAGNETIC CLUTCH IS STATIONARY WHEN MORSE KEY IS RELEASED. IT BECOMES ENERGIZED AND JERKS REVOLVING DISC AWAY FROM CLUTCH, ELECTROMAGNET CAUSING DISC TO HALT ABRUPTLY, THUS STOPPING SHORT THE FELT WHEEL AND ITS SOUND. THIS MAKES THE MORSE SIGNALS CLEAN CUT AND

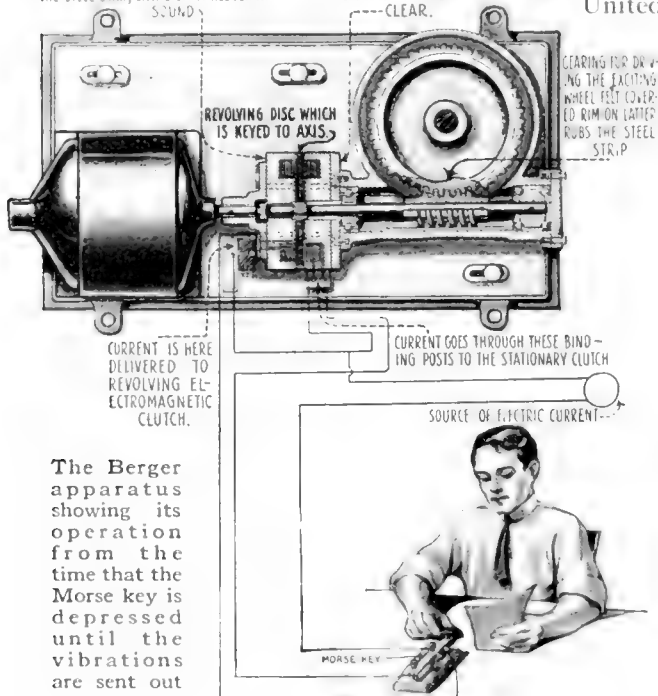

The Berger apparatus showing its operation from the time that the Morse key is depressed until the vibrations are sent out

together. Since all sounds come to the listener alike, it is obviously impossible sometimes for him to tell whether he is listening to a bell or to some strange noise of the sea.

Mr. Berger's submarine signaling device, however, has the one great advantage that sounds sent out into the water can be made to have any duration desired. As long as the felt-rimmed wheel keeps rubbing on the steel strip, a steady, sustained note is sent outward. As is explained in the illustration above, the rubbing of the wheel against the strip is under control of a telegraph-key, the sender operating this just as he would one on an ordinary electric telegraph circuit. As the first illustration on page 712 makes clear, these

signals sent out into the water are picked up by a microphone (delicate form of telephone transmitter) mounted in a water-filled chamber in the side of the receiving vessel. The listener simply adjusts telephone-receivers to his ears and hears signals just as he would hear ordinary wireless telegraph messages. This sound-wave telegraph is as truly a wireless telegraph as the kind using electric waves.

Commander F. L. Sawyer, of the United States Navy, has proposed that the Berger invention be combined with ordinary wireless telegraphy, the two together forming an effective means of warning in case of fog. The fact that electric waves travel with the speed of light (186,000 miles per second), or almost instantaneously, and that sound waves in water travel much more slowly (4,708 feet per second), is the basis for the proposed method. The electric signals and the sound-signals are sent out simultaneously by the approaching vessels. The listener on either boat hears the wireless signal instantly and the sound-signal a few seconds later (it having taken that long to arrive) and he can judge fairly well how far apart the two vessels are—the number of seconds

in this interval multiplied by the speed of sound in water giving the approximate distance. If the time intervening between receiving the two signals grows less and less the operators know that the two vessels are approaching and may collide. A code system, composed of different letters of the alphabet and indicating whatever course the vessels are pursuing, is also proposed.

Professor R. A. Fessenden has invented an underwater sound-signaling machine somewhat like Mr. Berger's. His contrivance, however, makes use of an electromagnetic oscillator working on one of the plates of a vessel's hull in place of Berger's vibrating wire. Both contrivances are effective means of communicating with submerged submarines.

Combined Velocipede and Hobby-Horse

A RECENTLY invented figure toy devised by Daniel Markmann, of St. Louis, Mo., combines the velocipede with a hobby-horse. The legs of the horse are pivotally attached to the body and have projecting pieces positioned to engage arms on a sprocket-wheel within the body of the horse.

By this means, movement of the legs is obtained and a life-like appearance that is pleasing to youngsters generally, is given the toy. The chain which operates the rear wheels is connected through the supporting hollow post to another chain geared to the velocipede.

Within the hobby-horse is a sprocket connected with the wheels through mechanism in the central pillar.

The legs of the horse swing backward and forward, giving the impression of a prancing steed to the youthful owner, while he is getting the same amount of exercise with his pleasure that he would on the ordinary velocipede.

The toy is light in weight and easy-running, and the bridle is adjustable.



Within the hobby-horse is a sprocket connected with the wheels through mechanism in the central pillar



One of these steam-operated sawing machines attended by a gang of four men will perform more work in an eight-hour day than thirty woodmen

Felling Trees Economically with a Mechanical Swordfish

THE growing demand for lumber in England and the shortage of labor has resulted in the invention of a tree-felling machine which is said to perform more work in an eight-hour day than thirty woodmen. A feature of the machine is the cleanness of the cut and the closeness to the ground at which the saw works, leaving no trunks standing and thus preventing waste.

The machine is mounted on removable wheels for transporting it from place to place. It consists of a steam cylinder fifteen inches in diameter with a piston-rod having a nineteen-inch stroke. It is attached to a light wrought-iron frame of triangular shape, so that the saw can be fed up to its work by means of a hand-wheel worm.

The saw is fixed to the end of the piston-rod and the teeth are designed to cut on the inward stroke only. The blade slides between guides, and there is no possibility of buckling. The boiler is heated by refuse wood picked up wherever the machine may be used.

It is especially advantageous for clearing timber from land destined to be used for buildings, parks or roadways, where an even surface is essential.

# A Daylight Developing-Tank

An ingenious apparatus which enables the photographer to develop his photographic plates in daylight

ALL outdoors is the vast laboratory of the camera enthusiast when he is taking pictures; but when he develops them he has to confine himself to a stuffy, insanitary darkroom and there work as best he can with acids, despite the developing tanks on the market.

Had Colonel Roosevelt a suitable and convenient means for developing on native soil his pictures of the River of Doubt they might have been saved. As it was, a large and valuable collection of photographic plates was lost when the supply boat carrying them was capsized. The plates were recovered but immersion had ruined them.

Misfortune of a somewhat similar nature attended the exploration party headed by Carl Akeley, the hunter and naturalist, on one of his trips into Darkest Africa. The climate of Africa is particularly severe on photographic materials. Mr. Akeley had taken a large number of animal and native pictures but he was wounded by a charging elephant. When he arrived at the first place where

he could have his plates developed (he had intended to reach this place fully sixteen months earlier) he discovered that his pictures were worthless.

To provide the photographer with an apparatus which will make it possible for him to develop his plates as soon as he desires, and to enable him, at the same time, to work independently of the darkroom, Raymond A. Woodman, of Mitchell, South Dakota, has invented a developing tank by means of which plates may be loaded as well as developed in daylight.

In brief, the apparatus consists of a transferring-hopper which is nothing more than a receptacle for transferring the plates to the developing tank; a lock-bar which locks the plate-holder of the camera securely to the hopper; a locking-dog, which, when released, enables the hopper to enter the tank with the plate, and a handle and quadrant with twelve points representing the twelve compartments for plates in the tank.

When using

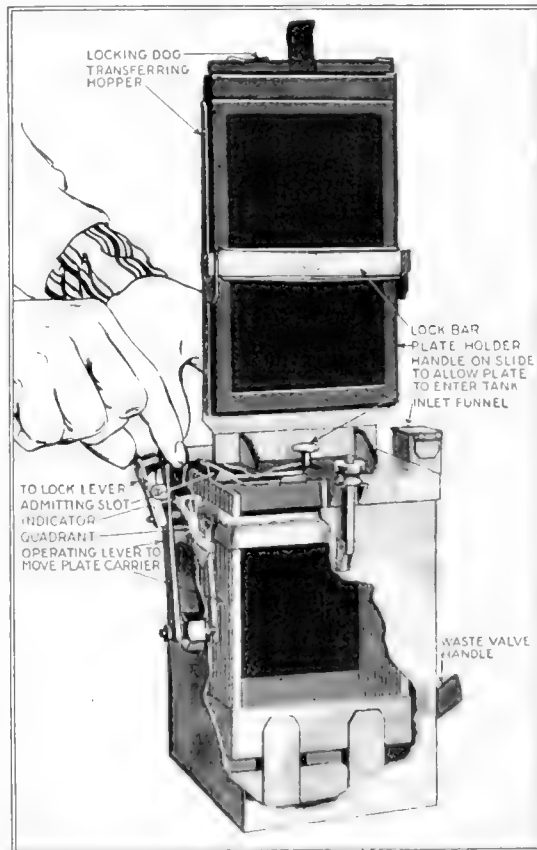

The daylight developing tank ready to receive its first plate. At the top is shown the transferring-hopper with the plate-holder held securely in place by the lock-bar. The tank proper consists of a handle and a quadrant with twelve points representing the twelve interior compartments for plates; a handle on a slide to open the admitting slot just long enough for the plate to pass through; a funnel through which the developer is poured, and a waste-valve drainage

Mr. Woodman's apparatus consists in placing the handle of the developing tank on the first position of the quadrant, on line marked I. This insures the insertion of the first plate in compartment I of the tank. The plate-holder of the camera is then removed from the camera box and placed in the transferring-hopper for its entrance into the tank. After it has been securely fastened to the hopper by the operation of a lock-bar, the slide on the holder is withdrawn without exposing the plate.

Because the transferring hopper is lined with black felt, making a light-tight joint with the holder, the plate is protected from the light while it is being passed from the holder to the hopper.

Next, the plate is projected into the tank. This is done by releasing the locking-dog attachment



Introducing a plate into the tank. The handle is pulled back just long enough for the plate to pass through

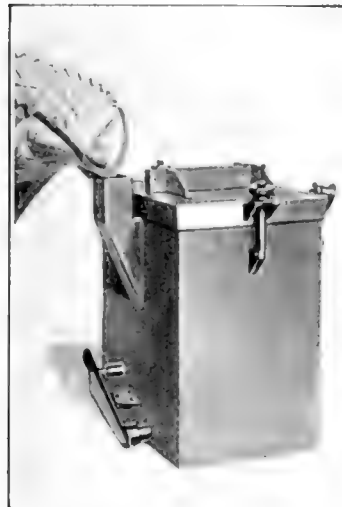

Pouring the developer into the tank through the funnel. The plates are left in the solution for about ten minutes



Placing the camera plate-holder in the transferring-hopper for its entrance into the tank. It is securely held in place by a lock-bar. Afterwards the plates are washed and placed in the fixing bath in the same way for fifteen minutes

and pulling back the handle, which opens the admitting slot and closes it automatically as the handle is released. This protects the plates in the tank while the plate-holder is being changed.

The handle on the hopper is then advanced to the second line on the quadrant, the plate-holder is reversed, and another plate inserted. The operations are repeated until the tank is loaded. At this point the transferring-hopper is pulled out of the slot in the tank cover.

The plates are now ready to receive the developing and fixing bath. It is not necessary that all twelve plate compartments be filled to carry out the developing operation. One plate may be developed as easily as twelve. However, twelve plates can be developed at the same time and the solutions saved each time.

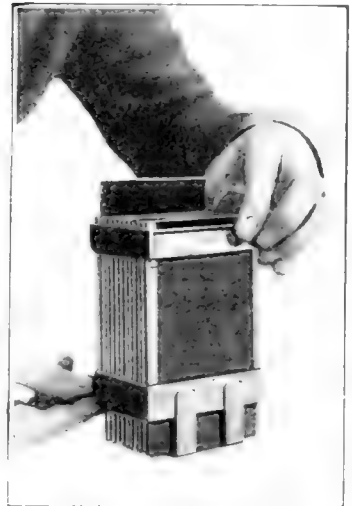

The plates removed in bulk from the tank after the fixing bath. They are now ready to be thoroughly cleaned and dried

# Toys That Obey Your Voice

Talk, sing, whistle, clap your hands and they perform their antics for you

**W**ITHIN the last two or three years a number of inventors have turned their attention to the making of toys. The result has been a series of contrivances of great originality and novelty. As an example of these new arrivals, the various sets made up of toy I-beams and cog-wheels and such by which young builders construct marvels in the way of bridges and engines and clocks, etc., may be cited. Still another toy consists of long wooden rods which may be put together in such assorted ways that anything from a windmill to a realistic airship may come into being. But for sheer novelty, a new style of toy devised by a New York inventor, Mr. H. Christian Berger, has easily strongest hold on the attention.

Everybody knows that a loud sound may so jar a telephone transmitter that it will cause a wave of electric current to flow through an electromagnet, or in some cases, a relay, and cause the electromagnet or the relay to act. If the jar is great enough to cause the electromagnet to release a spring or lever you can imagine the possibilities.

On this principle Mr. Berger has built a little kennel six or

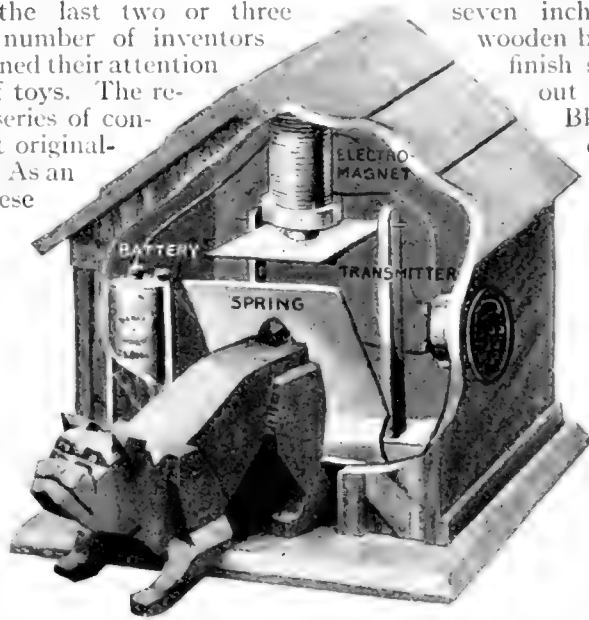

The secret of the wireless pup's obedience to the clapping of your hands is a microphone

seven inches high with a wooden bull-dog in mission finish standing half way out of the entrance.

Blow a shrill whistle or clap your hands and the dog instantly leaps out of his kennel. He seems alive, and yet, when you pick him up, you find that he is so much dead wood, without a spring or mechanical attachment of any kind. The explanation is that the sound of the whistle or of the hand-clapping has affected a tele-

phone transmitter concealed within the kennel, causing an electromagnet to release a spring which propeled the dog outward.

Still another toy which utilizes the sound-wave-telephone-transmitter principle is an imposing toy bank. To deposit money in the bank, you place the coin on a lever lying across the front steps, clap your hands, and presto!



Place the coin on the lever, clap your hands, and presto! the lever "flops" it into the bank

the lever "flops" the deposit straightway into the bank, a hole luckily having been cut in the front door at a convenient point to permit this hurried entrance of the coin. No deposit slips are needed. The bank will as readily accept a trouser's button or any other flat round object as it will a coin. However, the contrivance has enough action to adequately satisfy all demands made by a youthful banker. The interior mechanism of the bank is much the same as that of the dog kennel.

In a third toy the loud report from a gun actuates the mechanism. The machinery is contained within a box from the side of which projects a bent piece of heavy wire serving as a perch for a small stuffed bird about the size of a canary. The owner of the toy plays sharpshooter. By his accurate marksmanship he causes the bird to depart this life. The weapon with which he is equipped is a deadly "pop-gun," which fires the usual cork projectile, tethered to the gun-barrel with a string. Standing off several feet from his prey, the young sharpshooter takes careful aim. Bang! Off falls the bird from his perch, theoretically shot dead. It even matters not that the cork could go no further than the yard or two of limiting string; the bird is "shot" just the same. Likewise (and whisper it!) the marksman can even point the gun at his own head instead of at the prey; yet the bird on the other

side of the room falls off its perch precisely as before. The explanation is that the sound from the gun has affected a form of telephone transmitter as it did in the other toys, here, however, resulting in a jiggling of the bird's perch, causing it to lose its equilibrium and to fall off.

In the fourth contrivance a dummy figure is made to dance a jig in response to a tune whistled or sung. Details of the toy's workings are explained in the drawing. Because whistled or vocal sounds

are more delicate than the noise produced by clapping hands or the shooting of a gun, it is necessary in this toy to insert a relay in the telephone transmitter circuit. The transmitter works the relay and the relay controls the dancing. In the other toys the transmitter is directly controlled.

The dummy produces a variety of weird steps from a Charlie Chaplin shuffle to an old-fashioned Negro "hoe-down" dance.

The application of the principle is only limited by the imagination and ingenuity of the inventors and manufacturers. It will be a great relief to Santa Claus to find that he is to receive this kind of help in his toy-making; for the poor old fellow has been sadly perplexed during recent years by the precocious brand of twentieth century youngsters, who are constantly demanding something different and preferably something capable of energetic and more or less spontaneous action, as in the electromagnetic toys.

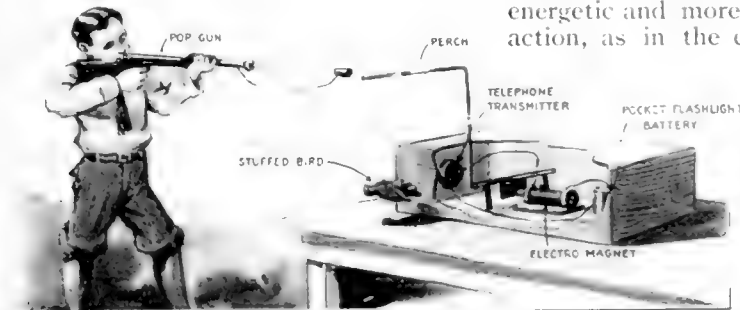
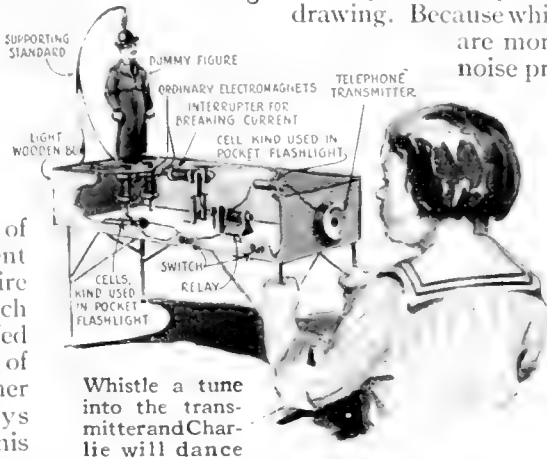

The bird never fails to fall off. It is the "bang" and not the shot that theoretically kills him. For instance, point the gun at yourself and he will fall off just the same



# Boring by Photography

## Keeping a Deep Hole Straight

**I**N ALL deep borings the diamond drill deviates considerably from its starting direction, and it is sometimes very desirable to obtain a survey of the hole. The device here shown, which is the invention of Charles B. Galvin, of Cornwall-on-Hudson, New York, consists of a steel tube, ranging from fifteen to thirty feet long, with means for indicating and recording any departure of its axis from a straight line. A geometrical straight line, tangent to the curving axis of the hole, is established by the projection upon a disk of sensitized photographic paper of the image of cross-hairs etched on clear glass. Thus, if the hole is perfectly straight the image of the center of the cross-hairs will coincide with the center of the paper disk, and if not, the distance from the image of the center of the cross-hairs to the center of the disk represents the amount of deviation or rate of curvature of the hole.

The vertical and horizontal directions are established on the paper prints by means of the image of a weight, which may be either a plumb-bob or a ball, free to roll to the lowest point immediately in front of the paper. A diameter drawn through the center of the print of the ball or axis of the bob indicates the vertical and the one at right angles to this, the horizontal. To these lines the lateral and vertical deviations respectively are referred.

A source of light, which may be a one or two-candlepower battery lamp, current for which is supplied from the surface via the cable, is situated in the focus of a condenser-lens. A well-defined image of the cross-hairs is thus projected on to the paper disk at the other end of the tube, by means of the objective lens which is interposed at the proper focal distance between the cross-hairs and the paper. The distance from the cross-hairs to the objective would usually be from two and a half to three and a half or four feet and from the objective to the paper, from twelve to twenty-five or thirty feet.

Applying the photographing device to a deep bore to determine whether it is straight or not. The sensitized photographic paper is at the extreme bottom of the device

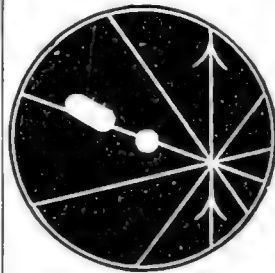

Above: A photograph which represents the amount of deviation or rate of curvature of the hole. At left: The location and arrangement of the photographing device. The lamp is at one end of the tube and the photographic paper at the other

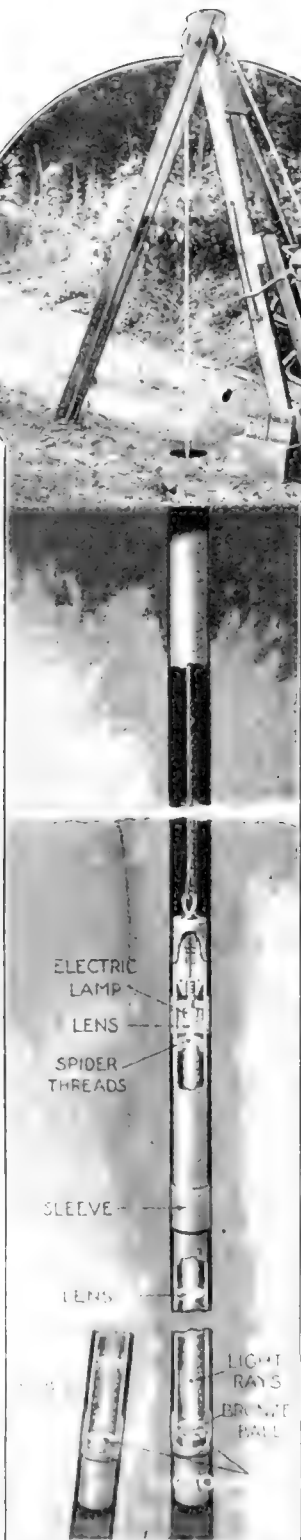

# Defending the United States with Motor Torpedo Boats

How deadly torpedoes can be safely carried on high-speed motor boats and how the landing of an enemy could be prevented by their means

By Edward F. Chandler

ON THE Atlantic coast alone there are no less than one hundred and sixteen undefended points where an enemy could land troops. New York, long considered invulnerable, is in reality helpless. Its guns are so mounted that an enemy fleet could lie off Far Rockaway and throw shells into Fourteenth Street. Not one of our guns could touch the invader.

Our own army officers have pointed out that 400,000 men could easily be landed on the Atlantic coast; that they could possess themselves of a line three hundred miles long, extending from Lake Erie to Chesapeake Bay; that they could hold that line at the rate of one man for every three yards or 176,000 for the entire length; and that the rest, 224,000 strong, could cut off ten of our states, all of our great manufacturing establishments, our munition plants, and our richest cities and financial institutions from the rest of the Union. In our

harbor defences we have less than 15,000 men, who must remain where they are stationed to serve their guns.

Against this foreign invading force we could oppose no adequate resistance. The popular notion that we "can lick all creation" with pitchforks and shotguns finds no justification in our military history. In the War of 1812, Washington was defended by 5,400 raw recruits, mostly militia and volunteers. About 1,500 British soldiers ignominiously drove out the American defenders of the capital with a loss to themselves of only eight killed and eleven wounded.

Years must elapse before our coast defences and our mobile army can be developed into fighting units capable of frustrating an invasion of our seaboard states. In the meantime we must make the most of the civilian *matériel* at hand. And so we find that during the month of September the Navy taught a handful of motor-boat owners how to look for sub-

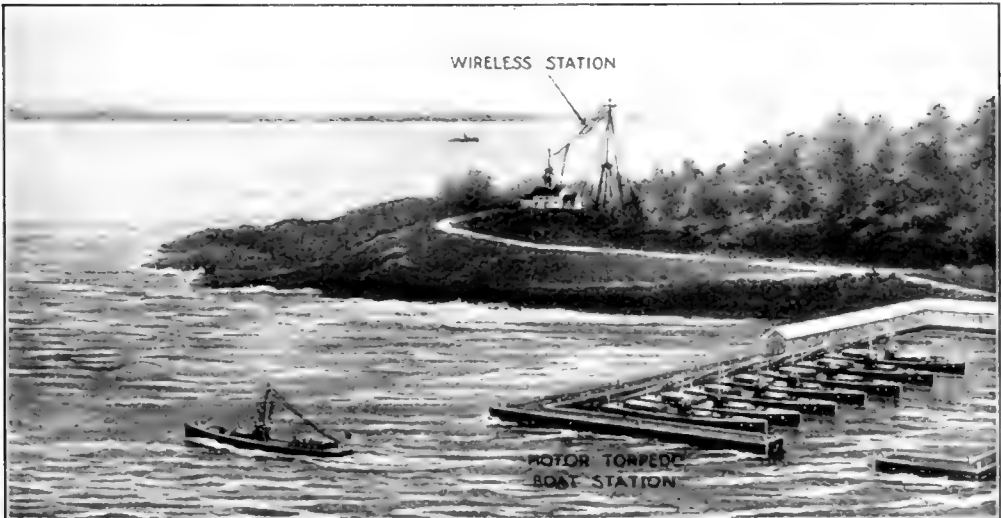

Each of the proposed motor torpedo-boat stations would be equipped with wireless sending and receiving instruments and would harbor from ten to fifteen boats

marines, how to locate mines, how to act as scouts and patrols, and how to perform, in general, the functions of a mosquito fleet. The Navy Department has gone even further. It has recommended the adoption of designs for power boats, which are to be so constructed that they can mount a gun in the bow in time of war and yet not interfere with their use as pleasure craft in time of war. These vessels can be employed only near shore for patrol duty.

Our thousands of miles of coast line can never be so perfectly protected by shore batteries that a landing by a hostile force is impossible. A powerful navy must always be relied upon to engage the fleet that is conveying a fleet of hostile transports. Since we are a fourth rate naval power it is not likely that our ships will be able to cope successfully with the superdreadnoughts and battle cruisers of any great European power. It would seem as if the transports would surely land their troops after the defeat of our small battle fleet. Coast defence submarines would naturally be used to thwart the attempt at landing troops. They must be mobilized for the purpose. At present our submarines are inferior to those of Germany or England, and we have not enough of them to defend thousands of miles of coast. What is more, a modern submarine costs \$600,000.

### Limitations of the Motor Boat

It is very evident that we need a weapon of defence which can be created almost overnight, as it were, which shall be at least as effective as a submarine, and which will appeal to the imagination and patriotism of coast dwellers. No doubt the motor boat meets the situation, and for that reason the efforts of the Navy Department to enlist the services of motor boat owners in the cause of national defence are commendable.

But the possibilities of the motor boat were hardly revealed in the recent maneuvers. Handled as they were last September they would have been powerless to prevent the landing of an enemy. Our Navy Department sees in the motor boat only a scout, a submarine antagonist, a mine detector, and not its larger possibilities.

There is no reason, to my mind, why the high-powered motor boat should not be employed to carry and discharge torpedoes. A torpedo, whether it is carried and discharged from a submarine, a torpedo-boat destroyer, or a motor boat will sink the largest battleship with equal effectiveness. But it must be carried safely and launched accurately. How this can be accomplished the accompanying illustrations of a motor boat of my own design reveal.

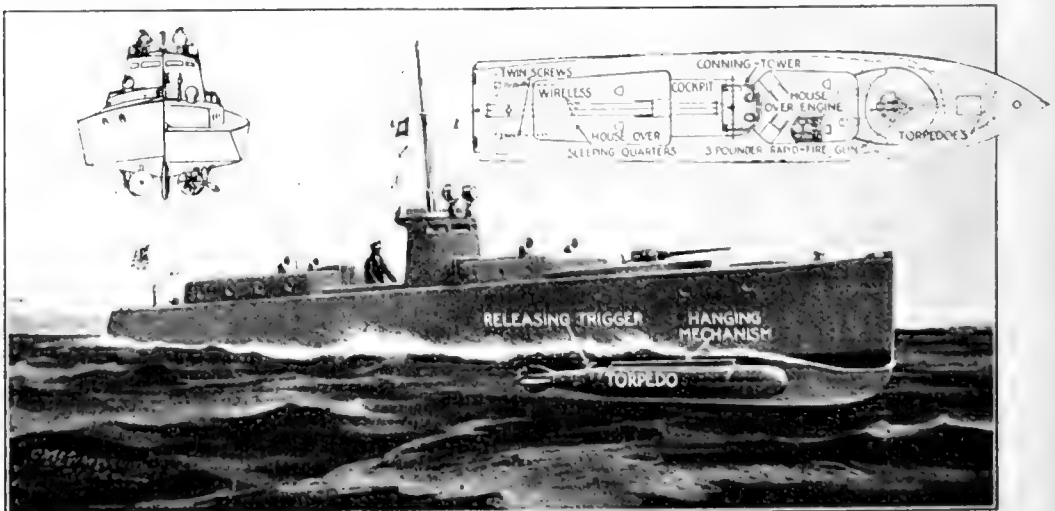

The torpedoes are attached to the hull, one along each side of the keel. Above: Diagram of the plan of the motor boat and end view showing the torpedoes suspended in position

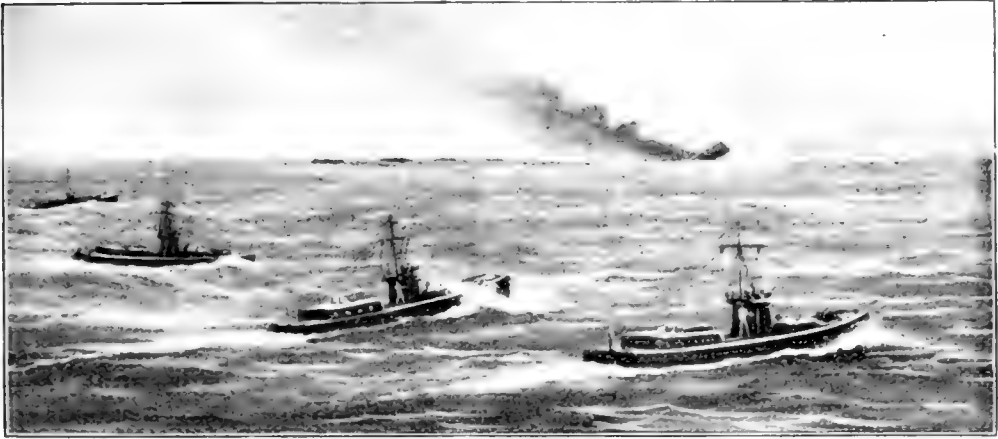

Should an invasion of the United States be attempted the first troopship to appear on the horizon would be immediately attacked from all directions by the mosquito fleet

A modern torpedo is nineteen feet long and twenty-one inches in diameter, and it weighs over a ton. Obviously it cannot be carried on the deck of a small motor boat, or in an overboard tube. Accordingly I have devised a method of attaching torpedoes to the hull itself, one along each side of the keel. Thus supported the torpedoes neither add nor subtract from the weight of the vessel; for the torpedoes have neither positive nor negative buoyancy. There may be a slight reduction in speed; but that disadvantage is far outweighed by the formidable character of the weapon carried. No launching machinery is required; the mere starting of the torpedo-propelling machinery is enough for launching. The torpedo is so suspended that it can be dropped off, whatever may be the speed of the vessel. Still more important, the torpedoes are launched with the motor boat bow on, thus facilitating fire-control. The motor boat need only be pointed at its target; a torpedo launched from a deck-tube, athwartship, as on a torpedo-boat destroyer, may miss its mark because of a heavy roll. To be sure a motor boat will pitch; but pitching is never so marked as rolling and is more easily allowed for.

But is it not dangerous to carry torpedoes in this way? May not the motor boat be blown up by its own weapons? Rare experience convinces me that so long as the pistols in the warheads of the torpedoes are locked (and they will be unlocked only when the

torpedo is to be fired) there is no danger. A warhead, even though it is filled with five hundred pounds of guncotton can withstand a severe shock.

At intervals of about one hundred miles along our coast stations would be maintained for ten or fifteen motor boats.

#### *How the Motor Torpedo Boats Would Defend Us*

Imagine, now, an attempt to invade the United States. Two hundred miles at sea our fleet is engaging the enemy's battleships in an effort to stop him from reaching our shores. The outcome of the battle is at least doubtful. Meanwhile his transports steam on. A motor scout sees them. At once the wireless telegraphic key of a radio operator flashes to the nearest boat station the number of the transports and their bearing. The news is wired from station to station. A veritable swarm of motor torpedo boats sets out. Their commander employs regulation torpedo-boat tactics; a dozen boats are sent against a single vessel; one at least will strike a telling blow. The boats lie low; they are difficult to hit. The enemy's transports, on the other hand, are large and very distinct. Moreover, the range is a mile and a half. The pistols in the war heads are set. A half dozen torpedoes are launched at once against the broadside of the transport. There is the thunder of an explosion; a troopship dives head foremost into the waves; three regiments perish.

# The Automobile Street-Car

Six-wheeled traffic carriers which are remarkable for their short-turning radius and for their flexibility

**E**VOLVED from the jitney, a new type of trailer has been built to convert any automobile into an eighteen-passenger bus. It is based on the century-old principle that an animal or vehicle can pull more than it can carry. Yet the vehicle is new in that it is the first application of the trailer principle for hauling passengers, and in that the trailer-wheels track with those of the automobile, to which it is attached by a new means, thus producing a vehicle of short-turning radius, an advantage on congested streets.

The Fadgl system, as this type of vehicle is called, is adaptable for feeders to trolley lines and as a traffic tester of proposed new routes. It even bids fair to revolutionize street-car traffic in our cities by supplanting the street-car entirely because it makes tracks unnecessary, as well as poles and power houses, on all of which the original outlay and maintenance cost are high.

The trailers, which are made in two sizes, one for eighteen and the other for twenty-five passengers, can be attached to any automobile by removing the body aft of the front seat, which is retained for the driver and one passenger. The remaining passengers are carried in the trailer, which is supported on a pivot arrangement at the rear of the automobile.

Another somewhat similar six-wheeled automobile is shown in the illustrations opposite. It differs from the former in that it is made of Ford parts and employs the unusual construction of mounting the body flexibly on the frame at two

points instead of attaching it all along its length. The autoport, as the vehicle is called, will carry 2,500-pound loads and may be equipped with an ordinary express body as well as one for bus service.

It consists of a Ford chassis to the rear of which is connected a two-wheeled trailer made up of the front end of a second Ford frame, front axle, spring and wheels, the latter being the rearmost wheels of the completed vehicle. In addition to this frame, which is pivoted to the rear end of the chassis frame on a crosswise bar, there is another rectangular wood frame-

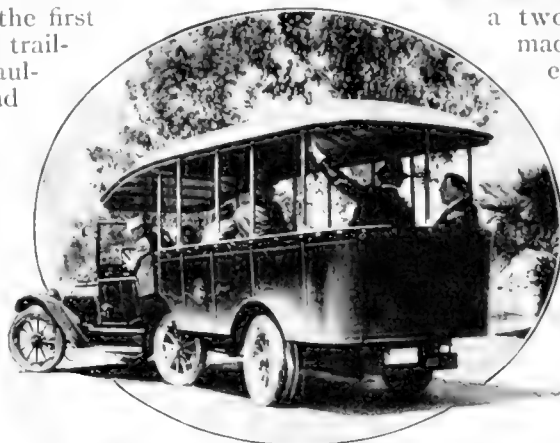

An eighteen-passenger, six-wheeled automobile bus with trailer wheels attached (Fadgl System)

work which joins the rear wheels to the housing of the Ford driving axle, or that on which the middle pair of wheels is carried. The forward end of this framework is also mounted on pivots on two straps around the axle casing, one near each wheel. The body is pivoted to two crossbars on the metal Ford frames, each bar being midway between the center wheels and those at the front and rear, thus tending to distribute the load equally over the six wheels.

Due to the pivoted connections of both the trailer frames and that of the body, any one pair of wheels is able to mount road obstructions without raising the body an equal height. The steering arms of the front and rear sets of wheels are connected by longitudinal cables attached to pivoted triangular-shaped equalizers at each end. Thus in rounding corners the front and rear wheels turn at opposite angles, tracking with each other and giving a short turning radius, one of the special features.

# Wonderful Six-Wheeled Automobiles



Above: An ingenious six-wheeled automobile, with the body mounted flexibly on the frame at two points (Autoport System)



At right: The autoport can carry 2,500-pound loads. Any one pair of wheels is able to mount obstructions without interfering with the other sets

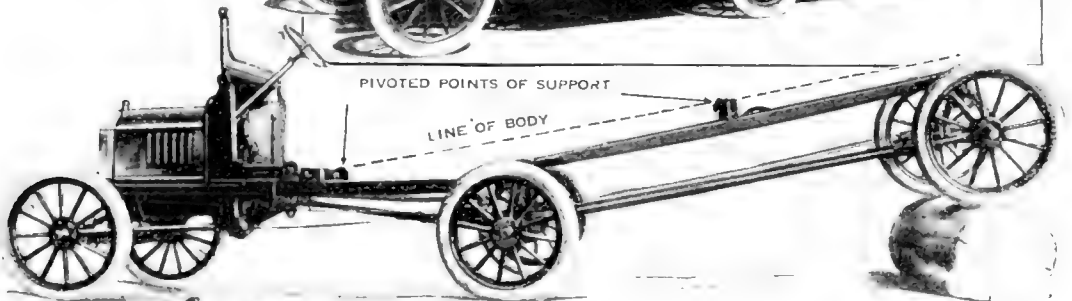

Above and below: The two pivoted points of support in the autoport system distribute the load equally over six wheels. The steering arms of both front and rear wheels are connected by equalizers at each end

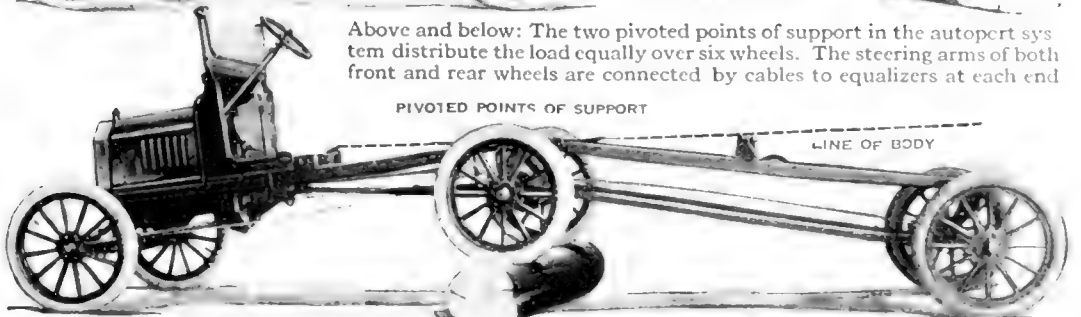

## How Nature Puts the Pop in Popcorn

**N**ATURE has filled a grain of popcorn with tightly packed starch-grains. The interior of the grain is divided into a large number of cells, each of which may be likened to a tin box, the walls of which are sufficiently strong to withstand considerable pressure from within. Upon the application of heat the moisture present in each little box is converted into steam that finally escapes by explosion. In some cases the explosions are of great force.

A very high degree of

heat is required for satisfactory popping. This causes most of the cells to explode simultaneously. The grain of corn then literally turns inside out, and is transformed into a relatively large mass of snow-white starch.

## A Mail Box Big Enough to Keep House In

**E**ACH year the residents of Syracuse, New York, invite their nearby friends and the rest of the world to the New York State Fair, which has been held in that city for many years past. This

year the Syracusans waxed eloquent and designed the huge mail box, shown in the accompanying illustration, for mailing several thousand letter and post-card invitations.

The box is about twelve feet high, six feet wide, and eight feet long. It was so big people couldn't mail their letters in the usual way, so a dainty postmistress was installed.

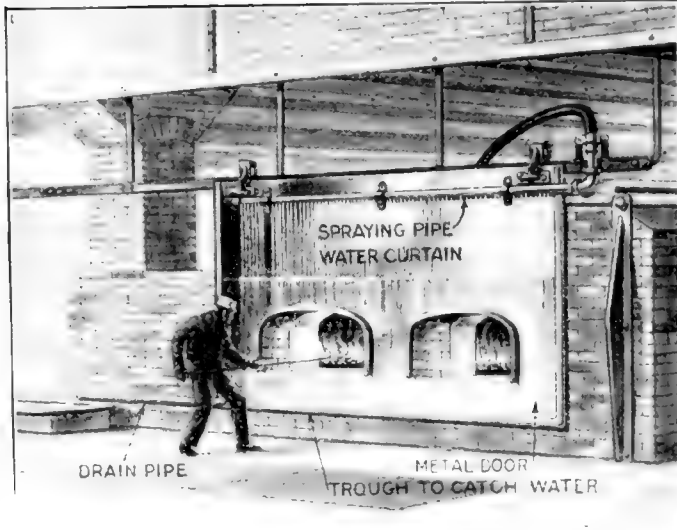

A curtain of cold water falling on a screen in front of the furnace partially neutralizes the effects of the terrific heat

## A Water Curtain to Protect Workmen from Intense Heat

**I**N OUR rolling mills the output of finished material falls off in the hot summer months, due to the intense heat radiated by the furnaces. Several means have been devised to protect workmen from these infernos. Among the most recent is a water curtain shown in the accompanying illustration.

It consists of a rectangular-shaped sheet-metal screen suspended by three door-hangers placed on an iron track.

The two furnace entrances have angle-iron around their edges to keep the water from affecting the fire. Riveted to the bottom of the screen is a trough which receives the falling water and conveys it to a drain pipe. At the top, extending lengthwise, is the spray pipe. This is equipped with a row of small holes in the bottom, through which the water flows against the curtain. The spray pipe is capped at one end.



Large enough to hold a postmistress and thousands of letters and cards



**A "Sandwich-Man" Clad in an Imitation Bullet**

**N**O, THIS is not a new type of diving suit, or a patent respirator used to repel a gas attack, or a new-fangled barrel for the fellow who has lost his clothes. It is merely an advertising stunt, a sort of super-sandwich-man, to attract the eyes of the curious. On the back of the device are letters which describe a product on the market. The conical headpiece resembles aluminum, and a circular opening is cut in it just large enough for the wearer to see his way ahead and breathe comfortably. The shorter the wearer the more mysterious becomes the appearance of the powderless bullet. If no part of the body except the feet are visible as the bullet wends its way down the avenue, it is pretty sure to be the cynosure of thousands of wondering eyes.



The newest recruit to the peaceful army of "sandwich-men"

**Why Gold Pieces Are Always "Doctored"**

**W**HY don't jewelers melt up \$10 and \$20 gold pieces in order to use the metal in the manufacture of gold jewelry? Indeed, gold pieces were used some forty years ago by enterprising jewelers and with success, too—until the practice was stopped in a very novel but effective way. In those days jewelers bought enough \$10 and \$20 gold pieces for the work in hand. The gold was melted, the necessary alloys were added, and all manner of fine Etruscan work was turned out.

It was not long, however, before the Government began to wonder what was becoming of its gold pieces. The officials knew the people

were not hoarding gold, so a quiet investigation took place. It was then discovered that the makers of gold jewelry were to blame. Having found

the cause, it was not difficult for the officials to find a cure. They did it

by "peppering" the coins with iridium. Resembling black emery in the crude state, iridium requires a heat of 3,542 degrees Fahrenheit to melt it.

Gold, on the other hand, can be melted at 1,913 degrees Fahrenheit. It is easy to see, then, how the unsuspecting jeweler, melting up his gold pieces at the temperature required, got a large number of unmelted specks of iridium in his metal when it cooled.

You can imagine his dismay when his analysis and deductions revealed that he had been trapped.

**Kneading Potter's Clay with the Bare Feet**

**T**HE illustration shows a man subduing a pile of recalcitrant clay. If it were possible to use his hands in kneading the clay the man would no doubt prefer to do so, but without a mechanical kneader he is obliged to use his feet, which method has been used for many centuries in the old world.

It requires no little amount of strength to knead clay, and when the feet are employed the weight of the body is utilized.



A modern potter kneading clay with his feet, as it was done in the days of Cleopatra

# Quebec's Disastrous Bridge

How the principle of a diver's spring board is applied in the building of the biggest cantilever bridge

By C. E. Drayer



One of the cantilever arm-compression diagonals being placed in position. Like the operations of an army in the field, the work of erection has a dash of danger and romance. As the success of the army in action is due to the output and character of the shops behind the lines, so the speed of erection of a structure is due to the excellence of the shop work

**T**HE new Quebec cantilever bridge ranks among the most important and brilliant of all construction. The boldness of a great general in war pales by the side of the courage of its builders, who had little precedent to follow in some of its vital and most difficult features of design and erection. Besides, they had to proceed in the shadow of the ghastly catastrophe of its predecessor which crumpled and fell, carrying to death nearly a hundred men.

That this shadow was not an imaginary one is evidenced by the recent disaster when the suspended span fell from fifteen feet above the water while being hoisted to position. The best engineers in American erred not in design, but, if at all, in failing to

be superhuman. The latest failure can delay for but a short time the finishing of the great structure. Very soon the successful placing of a new span will be recorded.

It all happened in about five seconds. While practically all dependable evidence of the cause of the last disaster is under two hundred feet of water, eye witnesses agree that, following a report like a cannon, the south upstream corner slipped off its lifting girder and corkscrewed into the river.

The most probable explanation of the failure is that the steel rocker casting under the south upstream corner suddenly crumpled (see diagram page 732). The truss then dropped on the short carrying girder, kicking it out, or

turning it enough to let the corner of the truss slip off. Had the accident happened an hour earlier, many prominent engineers of the United States and Canada who were on the span witnessing the lifting would have been lost. As it was but a dozen lives were lost.

The failure of the summer of 1907 cannot happen to the new bridge. While the lower chord of the old bridge was but four and a half feet square and had seven hundred and eighty-one square inches of solid steel in its cross-section, the same chord of the

new bridge is seven feet two inches deep and ten feet four inches wide and has a cross-section of nineteen hundred and two square inches of steel—two and a half times the amount in the old bridge.

The familiar spring board at the swimming hole is a good example illustrating the principle of cantilever construction adopted for the Quebec bridge. The load is carried by the projecting portion, which is supported by a weight at the back end sufficient to keep it from raising. The suspended span is like the boy standing on the end of the spring board. The suspended span and cantilever arm tend to raise the anchor arm, which must be heavy enough to prevent that

under any circumstances. Naturally the bridge engineers desired to keep the suspended span and cantilever arm as light as possible. Hence they made all the truss members of the suspended span and the greater part of the trusses

of the cantilever arm of nickel steel, which contains one per cent of nickel and is one third stronger than ordinary steel.

The designer must consider first the natural and artificial limitations of the location and then the traffic to be carried. At the location of the Quebec

bridge, the channel of the St. Lawrence River is nearly two hundred feet deep. The stream is swift and subject to high tides. The traffic of ocean-going ships must not be interrupted. These considerations, together with the kind of foundations

available, determined that the span over the channel should be eighteen hundred feet long, ninety feet longer than the famous Firth bridge in England, heretofore the longest span ever built. The length of span, together with economy and rapidity of erection, determined the type of bridge, a cantilever. The bridge will carry a double track railroad and two sidewalks.

After the main dimensions of the steel, "superstructure" it is called, had been figured out, plans for the masonry were made. The north stone masonry pier was carried to fifty feet below the bed of the river, twenty feet above bed rock, where a satisfactory foundation was found in the form of large and small boulders firmly wedged together. The south pier encountered sand for the whole distance. So it was carried to bed rock, eighty-six feet below the river bed. Most of the sand was removed by blowpipes.

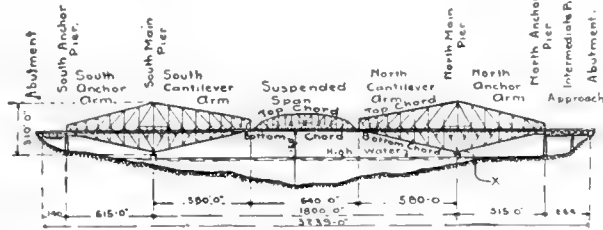
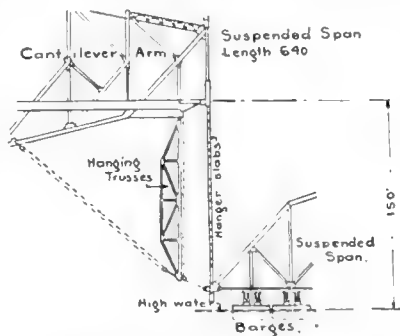
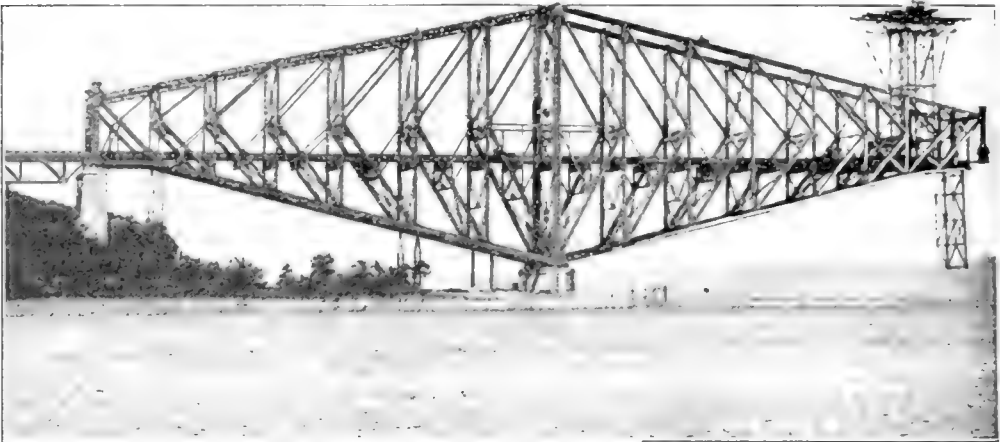

Diagram of the new Quebec Bridge. "X" marks the point where the bottom chord of the old structure crumpled. The expansion of cantilever arm and suspended span, due to temperature changes, is taken up by brake shoes at the connections, each capable of resisting a force of one hundred and twenty-five tons. Even the difference of temperature, due to one side of the bridge being in the sun and the other in shadow, was calculated with accuracy



The method of raising the suspended span in position. When the tide came in, the span was afloat and was towed by tugs to the bridge, where it was anchored to the hanging trusses and coupled to the hanger slabs. It was raised by hydraulic jacks

# The Quebec Bridge A Modern Wonder of the World



Picture continued on next page



The Quebec Bridge has a span over the channel of eighteen hundred feet, which is ninety feet longer than the famous Firth of Forth Bridge, heretofore the longest span built. Near the main post, the bottom chord for each panel weighs 400 tons, making it necessary to split it into four pieces in order that it could be carried by railway to the site

To the left, a picture showing how the floor of the anchor arms was erected on temporary staging. In order to manufacture the steel work an entirely new plant was built, equipped with machinery of unprecedented size and accuracy, costing a million dollars

Below is shown the bottom chord of the cantilever arm. The men are standing at the pin-bearing for the main shoes. The diameter of the pin is forty-five inches. Each rib is eight inches thick



# and the Terrible Disaster that Befell It

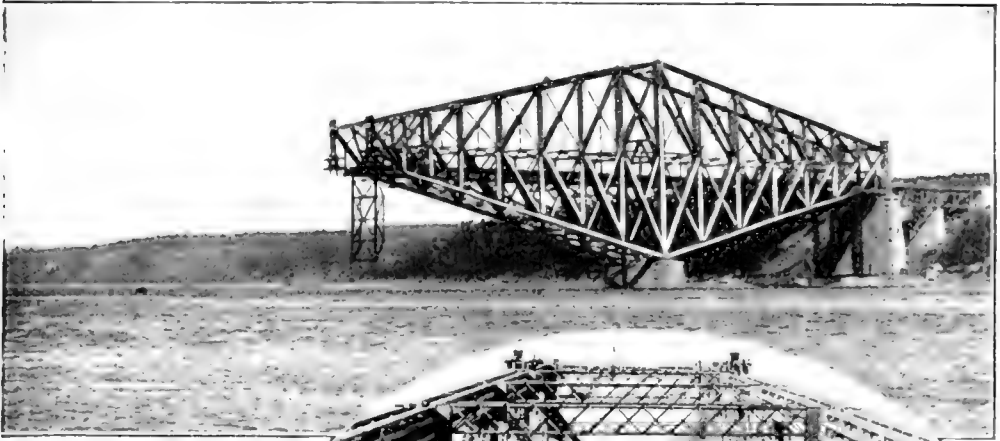

Picture continued from preceding page

Above: The steel frames hanging from the end of the cantilever arm. The picture shows the hanging trusses in place. To the right: The wind-bracing

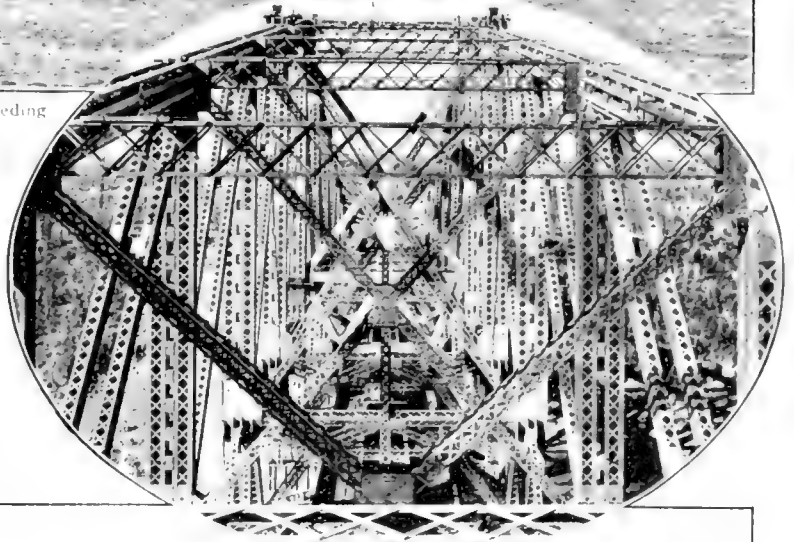

Below: The suspended span, weighing 5000 tons, photographed at the instant the mass struck the water

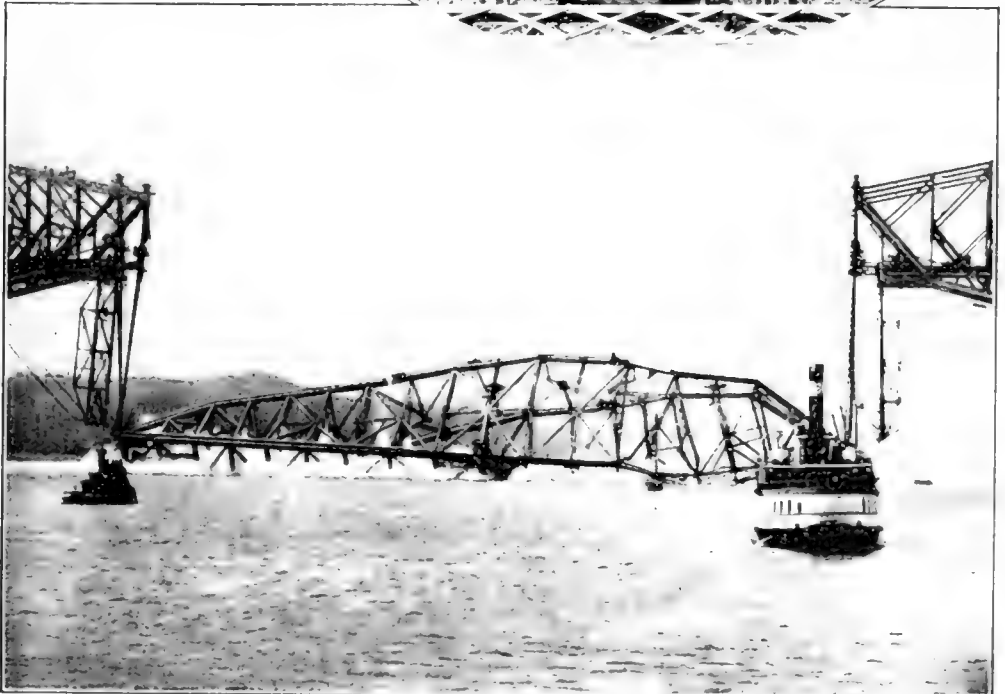

If the reader will pause a moment to look at the accompanying photograph of the bridge, he will note a series of perfectly good capital K's made up of vertical steel posts and diagonal rods. This picture shows also the traveler, which is nothing more or less than a great steel tower carrying gigantic movable cranes on top to handle the heavy pieces of steel, some weighing one hundred tons. By examining the diagram of the bridge, it will be seen that both north and south sections of the bridge, symmetrical about the main piers, are made up of a series of K's. The "K" system has a number of

advantages for a bridge of great size. Chief of these is that during erection of the cantilever arms, each panel or "K" can be completed without temporary supports and the traveler moved out to the end. It will be remembered that conditions at this bridge site made temporary supports out of the question.

The top chords of the arms are in tension; that is, the forces acting upon them tend to stretch them. So, they are made up of great eyebars, thirty-two of them on either side of the main posts having a cross-section of eight feet of solid steel. The bottom chords are in compression; that is, the forces acting on them tend to shorten them.

The great post over the main pier is three hundred and ten feet high and weighs fifteen hundred tons. It is composed of four posts latticed together into a rectangular tower nine feet by ten feet. The shoe under the main post has a bearing on the stone pier of twenty-two feet by twenty-six feet and is nineteen feet high, and weighs four hundred tons. Like some other parts of the bridge, it was shipped in pieces, each weighing one hundred tons. Another measure of the magnitude of this modern wonder of the world is the pin

connecting the shoe and tower. It is two and a half feet wide and weighs six tons.

Two sets of massive steel temporary viaduct were built under each anchor arm, one set to carry the floor system, which in turn carried the traveler; the other to support the lower chords.

During the winter of two years ago, the traveler, weighing a thousand tons, was built on the north shore. In the spring it was moved to the main pier and the shoes placed. The traveler then moved back from the main pier, placing the lower chords on the temporary viaducts. It was moved out to the main pier again and on the way back

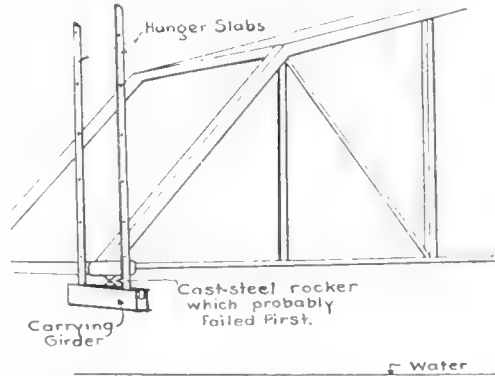

How did the disaster occur? Probably the steel rocker casting under the south upstream corner suddenly crumpled. The truss then dropped on the carrying girder, kicking it out or turning it enough to let the corner of the truss slip off

the trusses erected up to the point where the vertical and diagonal legs of the "K" intersect. Arriving at the anchor pier, it began to erect above the intersection of the legs of the "K."

Thus the anchor arms were erected. But when the traveler reached the main pier, it naturally had to erect the cantilever arm in front of it, panel by panel. A "flying bridge," projecting forward from the finished work, carried the permanent work of the panel until it was riveted up. The flying bridge was composed of pieces of steel with one end fastened to the completed work, the other projecting out into space and held up by suspension rods.

The suspended span was assembled in a shallow cove some three miles below the bridge at the same time the south cantilever arm was being erected. Six barges thirty-two feet wide by one hundred and fifty feet long were placed under as many panel points. When the tide came in the span was afloat and was towed by tugs to the bridge, where it was anchored to the hanging trusses and coupled to the hanger slabs. The plans were to raise it to its final position in a few hours by eight one thousand-ton hydraulic jacks, two at each corner.

# Making the Music Fit the Screen

The picture is rehearsed with the orchestra accompaniment and mechanical cues prepared

WHEN the hero's mother is gasping her final blessing as she prepares to depart from the screen to a celluloid heaven and the orchestra in the pit accompanies the pathetic scene with a deafening beating of cymbals and a joyous roaring of snare drums to the tune of "A Hot Time in the Old Town Tonight," it is no wonder that an audience decides that capital punishment for certain orchestra leaders would be an excellent thing.

Even the best moving picture theaters occasionally stoop to "incidental music" which fits certain photoplays about as accurately as a right shoe fits a left foot.

There is only one way to attain a harmonious relation between screen drama and incidental music. The two must be automatically coordinated.

Stanley W. Lawton, general musical director of a chain of New York moving picture and vaudeville theaters, has invented and constructed an electrical orchestra director which accomplishes this harmonious relation. The picture projecting machine in the booth absolutely controls the electrical orchestra director in the pit. The theory of the Lawton photoplay orchestral director, as it is called, is simple. By electricity, signals are automatically flashed to the orchestra from the projection machine on the screen as the picture progresses. Every few seconds a different signal

flashes, informing the musicians that sentimental, lively, or tragic music is to be played. The musicians' score and cues have been arranged beforehand during rehearsal. They merely read their part and follow the cues, changing from selection to selection as the signals instruct.

The machine in the center of the orchestra consists of a flat, oblong box with red glass sides, which surmounts a curious looking cylinder or drum. As the films are reeled through the projector, signals flash from the red glass box. For example, if the hero's mother is in death's embrace, the letters "TREM," meaning tremolo, are flashed, and the orchestra responds accordingly.

So accurate is the electrical cueing system that at a recent rather amusing but exacting test given the apparatus, the signal "DRUM" was flashed and obeyed at the very instant when a comedian on the screen hurled a chair through a window.

No matter at how rapid or slow a speed the film is projected, the timing of the cues to the orchestra will be accurate. This precision is obtained by an electric contact-maker operated by a gear on the shaft of the projection-machine handle (see page 735). Every time the handle makes fifteen turns a worm-gear causes electrical contact to be made, and a current passes through wires to the electrical orchestra director,

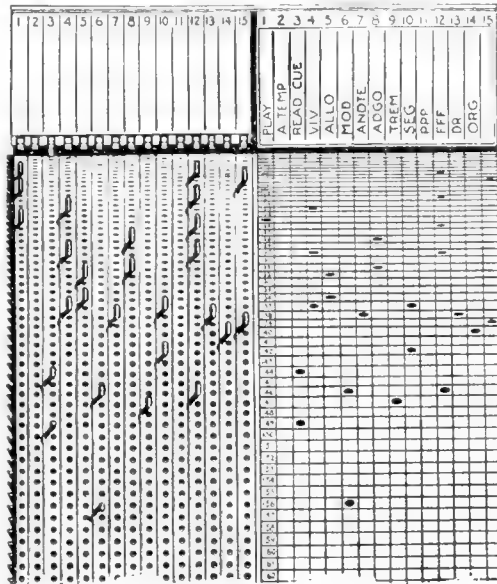

Inflections marked on the paper record are duplicated on the side of the cylinder by steel pegs that contact a magnet





WARNING SIGNAL



Stanley W. Lawton

The cue-machine is placed in the center of the orchestra and signals flash on both sides at once as the film progresses

which is placed in the center of the orchestra. The current actuates an electromagnet, the plunger of which catches in small notches in the left-hand rim of the cylinder and turns it

a short distance. Every time the contact at the projection machine is made, the magnet turns the cylinder a distance equal to one of the notches. The apparatus is so arranged that when the five or six reels of film which constitute the photoplay have been shown on the screen, the cylinder in the orchestra pit has made, in a succession of short steps, one complete revolution.

The face of this cylinder which is made from an ordinary steel pulley, is divided into two parts, as shown. Fifteen parallel lines of equally spaced small holes, are bored around one side, while a strip of ruled paper encircles the other. When the orchestra leader views the film for the first time he makes small pencil dots on the paper cylinder, as the drum slowly revolves. He has fifteen ruled off columns in which to place dots, each column being allotted to a certain musical cue. Let us say, for illustration, that the opening scene of the film calls for loud, exciting music. A stationary index-card, fastened on a frame above the cylinder, informs him that fortissimo, or *ff*, shall be indicated in column No. 2 on the paper record. He makes a pencil mark in that space. As the film progresses its dramatic quality changes, let us say, to

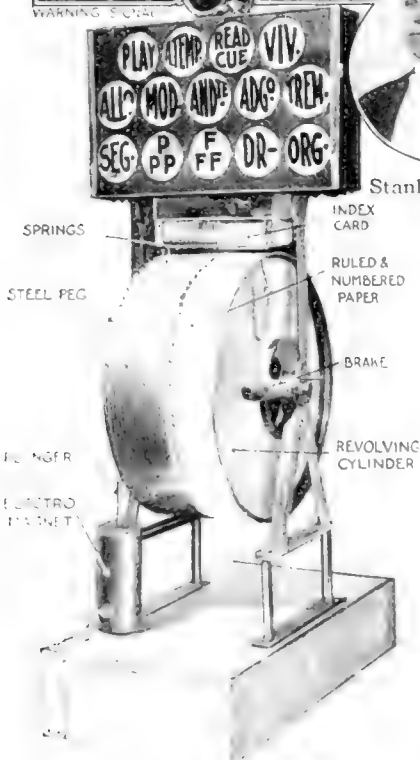

The cylinder is divided into two parts. A ruled strip of paper encircles one side and fifteen lines of small holes the other. The leader makes his inflection marks on the paper at the first rehearsal

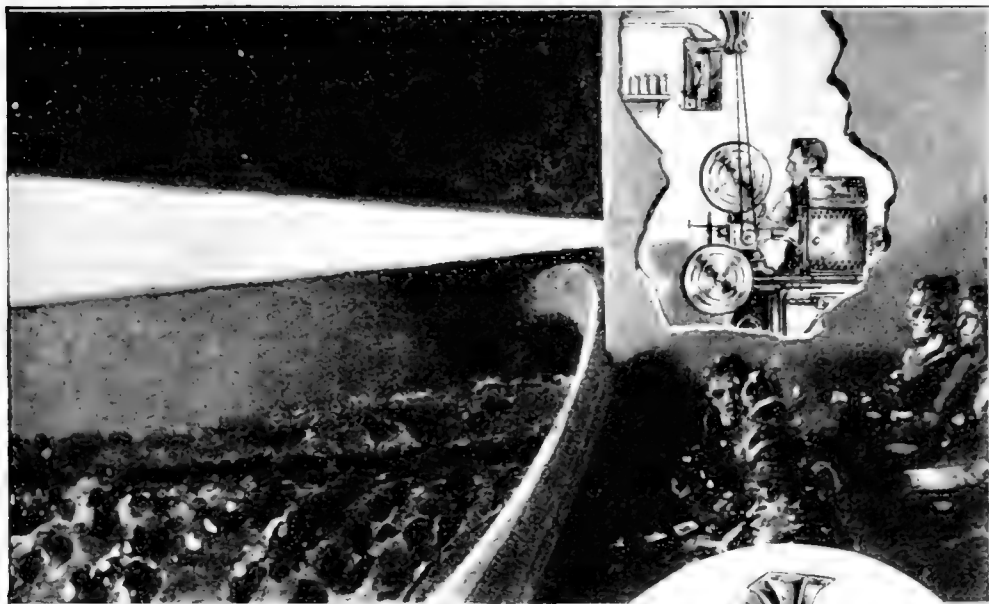

A worm-gear connects the shaft of the handle of the projector-machine with the steel pegs of the cue-machine

sentimental. The necessary orchestral accompaniment will be pianissimo. This shading is expressed, according to the index card, in column No. 1. By that time the control device on the projector has moved the cylinder a short distance, so that the pencil mark will be slightly lower than the first one. This operation is repeated until the film has run its course. The cylinder has made one complete revolution.

In order that the record of musical shadings marked in pencil dots on the paper record may be indicated by the flashing of cues in their proper order, the pencil dots must be duplicated on the left hand side of the cylinder by means of steel pegs fitted into the lines of holes. There are fifteen of these lines of holes corresponding with the fifteen columns on the paper record.

The first scene, we remember, called for music at fortissimo, and it was indicated by a pencil mark in column No. 2. Accordingly, a metal peg is inserted, parallel with the mark, in the second line of holes. When all of the pegs, corresponding with the pencil marks, have been inserted, and the cylinder is again revolved, the cue signals in the red glass box flash in their proper order. The signals are caused to flash by the metal pegs which press small springs upward, causing electric connections to be made, delivering current to the corresponding signal lights.

WIRES  
LEADING TO  
ORCHESTRA  
DIRECTOR

WHEEL REVOLVES  
ONCE EVERY 15<sup>TH</sup>  
REVOLUTION OF  
OPERATOR'S  
HANDLE

BATTERIES

WORM GEAR  
PEG  
BELT TO MACHINE  
CONNECTION  
TONGUE

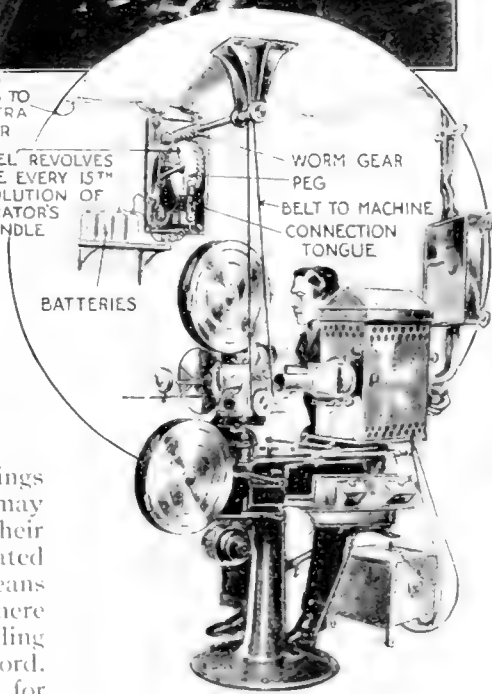

As the film is reeled through the projection-machine an electrical contact is made with the cue-machine at every fifteenth revolution. The moving steel pegs push up contact springs and the proper signal is flashed to the orchestra. When all the reels have been shown, the cylinder in the orchestra pit will have made one complete revolution

The signaling apparatus is placed in the center of the orchestra where the leader stands. Signals are flashed on both back and front simultaneously. All signals are in the regular musical terms. In order that the leader and orchestra members shall not be caught unawares by a sudden change in music to fit a corresponding change on the screen, a warning signal is provided. This consists simply of a red light on top of the signal box. The method of controlling the warning light is the same as for the other cues. Organ, trumpet or drum can have separate signal lights attached to their music stands. With Mr. Lawton's electrical orchestra director it is possible to alter the music to fit a scene every five seconds. Few scenes are of such short duration as that.

#### Ordering Meals Electrically in Quick Lunch Restaurants

**E**ATING in quick-lunch restaurants amidst a babel of discordant sounds from crashing dishes and shouts from frenzied waiters is a torture about to be eliminated. An electrical system of ordering for lunchrooms, clubs, restaurants and hotels has been devised. When an order is given the waiter will go to one or more sending stations conveniently placed and there push a button which will operate an annunciator installed in the kitchen and tell the kitchen hands just what food is wanted.

The sending station consists of a metal panel carrying a number of

electrical push-buttons. Over each button is a name-plate into which can be placed a celluloid strip on which is written the particular dish which the push-button is to represent.

From the sending stations cables are brought into the kitchen to form electrical connection between the push-buttons and the receiving station which is in the form of a cabinet, the front face of which contains as many electrically-operated indicators as there are push-buttons in each sending station. Each time the waiters press any of the buttons of the sending stations, the corresponding indicators in the kitchen register the number of orders for each dish, the indicators advancing one number each time the buttons are depressed.

As long as any orders remain unfilled for any of the dishes indicated on the receiving station panel, a tiny red light flashes at the lower left-hand corner of each unit. As the orders are filled and passed out

to the dining-room or lunchroom, the cooks press the corresponding push-buttons once for each dish, and the red light disappears.

The operating current is supplied by a storage battery. Two batteries are installed: while one is serving the system, the other is being charged.

As many as one hundred push-buttons can be arranged on a panel of a sending station where the list of dishes on the menu is very varied and extensive.



Press the "Pork and Beans" button and the "Pork and Beans" light flashes up in the kitchen. Thus you can now order your own meal in a certain Chicago lunchroom, or a waiter can order it noiselessly

# Miniature Magnet-Propelled Ships

The mysteries of window attractions explained

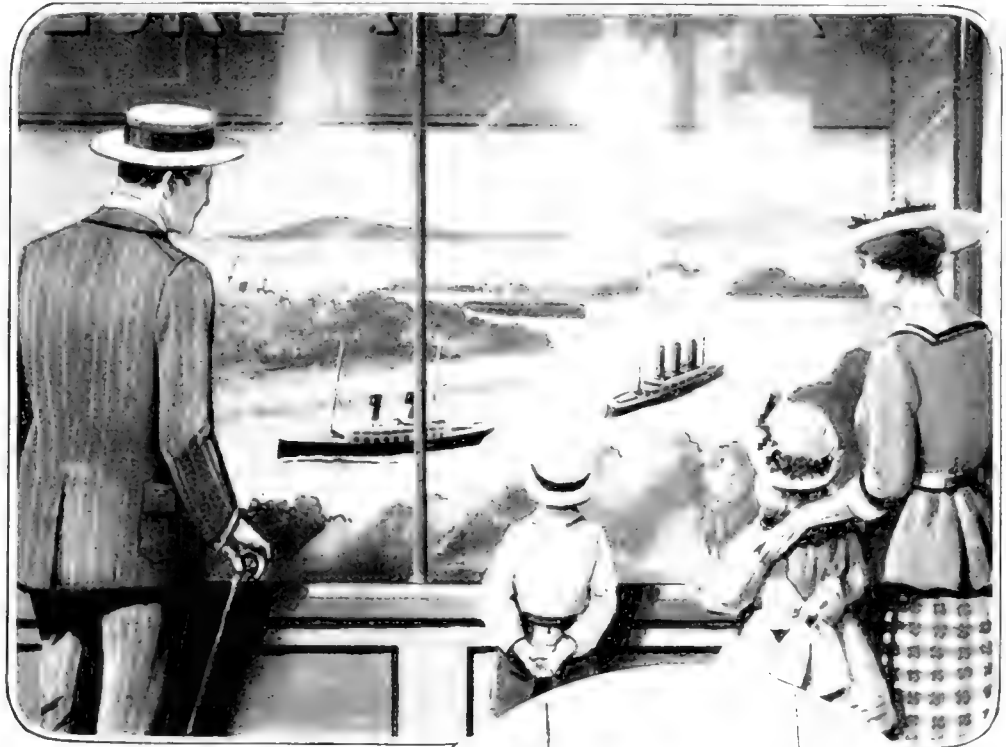

Above: Although there is no machinery in the ships they sail steadily along through the miniature waterways

At right: The magnet-trucks are run on toy-railroad systems, with switches, stops and signals under the water

**I**N MODEL representations of the Panama Canal, New York harbor and miniature naval engagements, vessels of different sizes are made to sail through little waterways in a manner truly mysterious, due to an invention by Louis E. Myers, of Chicago.

The ships move at a steady rate through the water. But as you watch them closely, you notice that the propellers are not moving. What, then, drives the ships? A soft, iron strip which hangs several inches below the hull has a

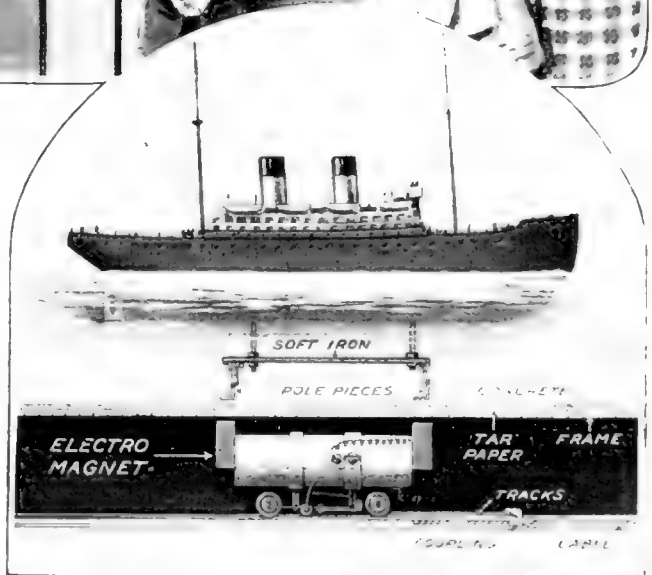

downward continuation at each end, terminating in pole-pieces which have connection with an electro-magnet running on tracks below the tar-paper-and-concrete "river bed."

## Teaching English Girls the Art of Milking

"WHAT are you doing, my pretty maid?" "I'm practicing milking, Sir," she said—or at least that is what the girl in the photograph might answer if you put the question to her in that way. She is one of a number of would-be-dairy-maids who are endeavoring to solve the problem of the labor-shortage in Essex, England. The instruction classes are under the direction of the Women's War Agricultural Association, and many women and girls, some of them less than twelve years old, are learning the fine points of the art of milking without inconveniencing the cow.

The device employed consists of a frame supporting a rubber bag which resembles the udder of a cow. The milk or substitute liquid is poured into the bag, from which it is coaxed by just the right pressure applied in just the right way.

## An Inventor Invents Because He Can't Help It

"ONE thing stands out conspicuously: the race of contrivers and inventors obeys an inborn and irresistible impulse," states F. W. Taussig, Professor of Economics in Harvard University. ("Inventors and Money-Makers." The Macmillan Company.) "Carterwright was in difficulties almost all his life; yet he never relaxed his interest in any and every sort of mechanical device. Edison made fortunes and lost them again; but throughout he remained the same amazing and persistent contriver. And it would seem that no satisfaction from pecuniary success or worldly recognition equals the absorbed interest of trial, experiment, novel problems, happy solutions."

## Doing the Family Washing in Your Rocking-Chair

UNDOUBTEDLY the washing-machine has proved to be one of the greatest friends which the erstwhile household drudge has found. Where there is an electric motor to run the machine it has reduced the labor of laundering to a minimum. But there is still a certain amount of tedious labor in connection with the one which is run by hand-power.

The illustration below shows an invention by A. W. Wolfskill, of Adamstown, Pa., which utilizes for the purpose the energy expended in rocking to and fro in a rocking-chair. Two springs under the seat of the chair, one at the front and the other at the back, are connected with the machine in such a way that the slightest movement of the chair is communicated to the tub. It is not necessary to rock violently in order to cause the machine to whirl its contents rapidly.



"What are you doing, my pretty maid?" "I'm practicing milking, Sir," she said



Two springs under the seat of the chair communicate the motion to the washing-machine

**Watching Dishonest Employees with the Aid of Mirrors**

A NOVEL fraud-detector invented by Henry Muller, of Philadelphia, Pa., enables the proprietor of a business, seated at his desk in another room entirely separated from the room in which his customers are being served, not only to observe the actions of his employees but to have before him at all times an accurate reproduction of the operation of the cash register.

If a dishonest employee fails to ring up the proper amount on the cash register, the proprietor in his room above can instantly detect the fraud. In brief, the invention calls for a cash register with special indicators which project upward, a mirror in a clock or other enclosure on the wall near the cash register, and a tube running through the floor to the proprietor's

desk, upon which is a glass through which the reflections of the mirror on the wall of the room below are visible.

The tube arranged in the position shown in the accompanying illustration would not excite the suspicion of employees. The indicators which move upward when the keys on the cash register are depressed to show the amount purchased are a part of the drawer. Each indicator is provided with a number. If ten cents is deposited the numeral ten moves upward to a certain angle and is reflected by the mirror on the wall.

**The Inventor of the Steam Engine Was Interested in Gim-Cracks**

"WATT was interested in a quantity of inventions and devices," writes F. W. Taussig, Professor of Economics in Harvard University. ("Inventors and Money-Makers," The Macmillan Company.) "Among them may be mentioned a new kind of clock which, to quote

Watt's own language 'is to be ranked in mechanics as riddles and re-busses are ranked in poetry.' Other "gim-cracks" were a micrometer; a drawing machine; a copying machine for letters, prototype of the copying devices now so long in use; a machine for drying linen and muslin by steam; one for getting illuminating gas from coal; a new kind of oil lamp long manufactured at the Soho works; and a smoke-consuming device, on the down-

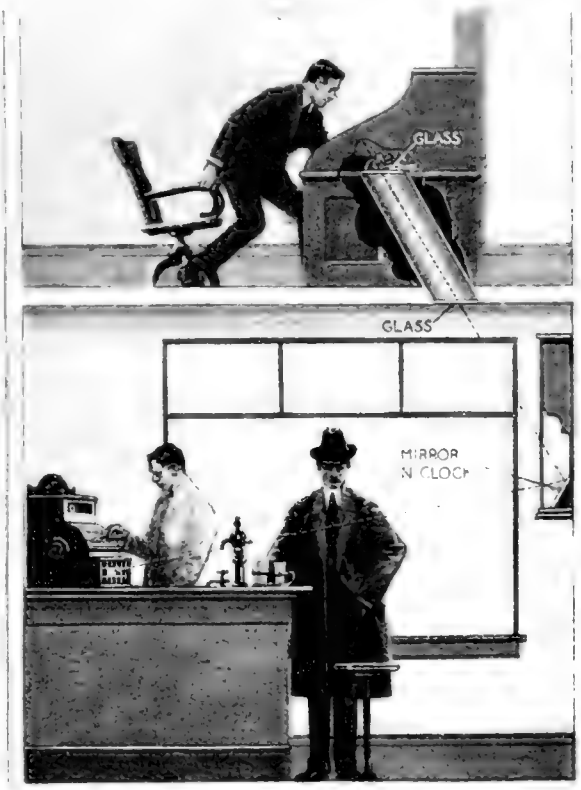

The proprietor, watching the glass on the desk before him, discovers that an employee is not ringing up the correct amount on the cash register

draft principle. Last, but not least significant, was a machine for copying (reproducing) sculpture, which he himself termed a 'hobby-horse,' and which seems to have amused and indeed absorbed him for the last twenty years of his life (from 1791 to 1819). Long after he was prosperous and honored, the old man spent much time in his garret, hot or cold, over this machine; he was sure it would succeed. He spoke of it as the 'diminishing machine.' The garret in which he worked at it was long preserved by his descendants."

# Breaking a Mountain Trail

Wheels had to be taken off and caterpillar treads substituted, and bridges had to be built

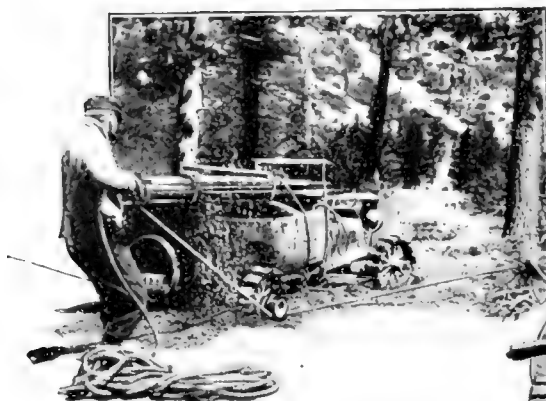

By means of caterpillar-type wheels, a portable bridge and a drum-and-rope device for crossing turbulent streams the trail was covered in two days

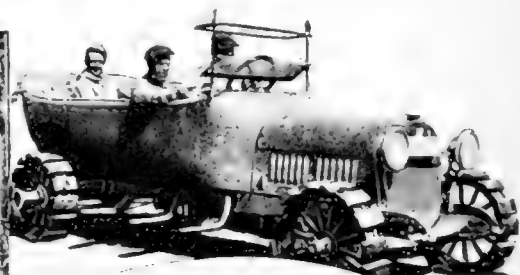

THE one annual sporting event in Southern California which is of unusual interest is breaking the trail into Big Bear Valley, a fishing and hunting resort on top of the San Bernardino Mountains, at an elevation of seven thousand feet. For years the automobile men and enthusiasts have contested for the honor of being the first to make the trip after the opening of the new year. The rivalry between these men has been made more keen since a sporting-goods house offered a yearly cup to the automobile and crew which should be the first to cross the divide.

Every winter the Big Bear Valley section is visited by severe rain, hail and snowstorms. Cloudbursts are numerous and there are several months during which the country around the tops of the mountains is literally frozen-up. During these periods it is impossible to reach the top by machine, and it is almost worth the life of a person to tackle the trip on foot. Before the winter is very old the trails and roads leading to the summit are made practically impassable by washouts, landslides and fallen trees.

The crew piloting the last successful car converted their wheels into the

caterpillar type. The aim of the crew was to proceed as far as possible on the inflated tires and when the going became too hard on the rubber to change to the caterpillar wheels. When the rubber tires were taken off they were hung to tree branches to await the party's return.

A portable bridge was carried for crossing streams, but there was one place where the temporary bridge was useless. This was a thirty-foot stream of swiftly running water. The men cut down a pair of large trees on the nearby bank, letting them fall across the stream so that they reached from bank to bank. They were then drawn together so that the caterpillar wheels came on either side of them, the axles being the only parts of the car which touched the logs. Strong ropes were fastened to trees on the farther side of the stream, the other ends being turned several times around drums fastened to the rear wheels. When the motor was started the drums turned and the machine simply dragged itself across the log upon its axles. Many times this drum-and-rope idea was brought into play when the car became stuck. Other crews that started on the trail did not reach the half-way house.



# "Shooting" Birds with a Camera

Making intimate pictures of bird-life

At right: A flock of wild ducks photographed by the gun-camera without disturbing the birds



Below: A great blue heron unconsciously posing before the distant gun-camera



The difficulty of getting close enough to the birds to secure such size or detail has been overcome by Stanley Clisby Arthur, state ornithologist of Louisiana, through



Above: Birds in flight are as easily caught by the camera as those at rest. At left: The great focal length used increases the size of the image secured



the use of a "gun-camera," which consists of an ordinary reflecting camera with the usual bellows extension, mounted on a carriage with wheels. The bellows is supplemented with a tube to admit the use of long-focus lenses.

In the camera illustrated the lens is recessed in the far end of

**T**O secure photographs of bird life so that the plumage detail, identification marks and such matters dear to the heart of the trained bird student or to those who merely delight in viewing pictures of nature, a large image of the object photographed must be secured.

the tube so as to have the benefit of a lens-hood when working against the sun or light, and focusing is accomplished in the ordinary way by the milled head.

The device when set up is perfectly rigid and enables Mr. Arthur to "pick off" birds at any height or in flight.

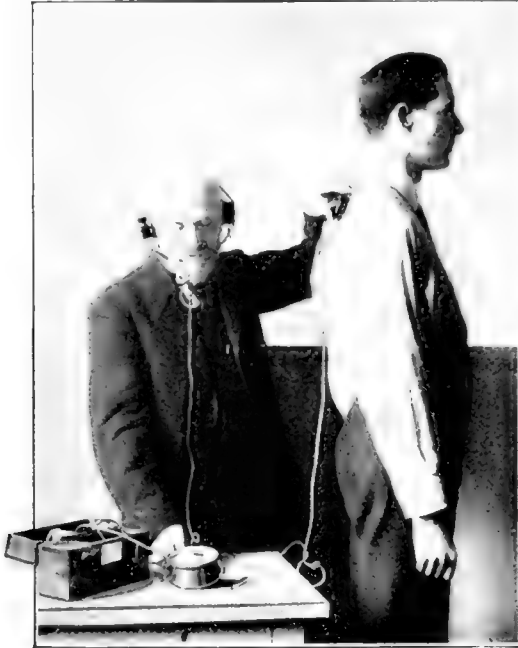

Hold a microphone against your back and it will pick up the sound of your voice

### Hearing Your Voice Through Your Bones

A FRENCH specialist, Dr. Jules Glover, has devised a method of picking up the vibrations of the voice in the bones and tissues of the body. He employs a galvanometer—in other words, a sensitive current-measuring device—in the circuit, with which is a microphone or sound-detector, the primary of an induction coil, and a battery connected with a voltmeter. The microphone is placed against the subject's body, so that it can be affected only after the voice has vibrated through a dense layer of bones and muscle. The voice is not actually heard, but rather visualized, since the galvanometer-needle swings out of its course as soon as the current flowing through the circuit is changed in the slightest. The current is so changed because the vibrations affect the microphone in the circuit from moment to moment. By including telephone receivers in the circuit of the secondary of

the coil, and fastening them to his ears, Dr. Glover also hears the sounds passing through the body.

Dr. Glover claims that his system renders it possible to take a patient's pulse far more accurately than is possible with the hand alone. He can count the beats both as they appear as fluctuations of the galvanometer-needle or as rhythmic clicks in the telephone receivers. Variations undetected by the hand are immediately observed. In this case the microphone is employed as a transmitter.

### A Motor-Wheel for the Railroad Velocipede

RIDING the rails on a velocipede propelled by a motor-wheel, the trackman traveling to make repairs has a special car of his own just as the railroad president has. For a good many years the trackman has had his velocipede and has hand-pumped it up hill and down dale until all novelty connected with the vehicle has long since been forgotten. With the introduction of the motor-wheel, however, he is again in the limelight. He can recline in his seat, operate the motor, and sail over the tracks without any expenditure of energy.

The motor-wheel can be attached to the velocipede and taken off without making any alterations. A casting which fits between the two lower rails of the velocipede serves as the connecting unit. It holds the motor-wheel securely in place, so that it cannot move either to the right or left, but stays constantly on the balls of the rail. The attachments permit of the free moving of the wheel.



The driver can recline in his seat, operate the motor and speed over the tracks without expending energy

The "Permanent Wave" of a Woman's Hair and Its Secret

A NEW process for making a permanent wave in feminine tresses has been invented by a New York man.

First of all the hair is divided into a greater number of strands than has been the usual practice. The part of each strand nearest the head is wrapped round a small curling rod. As it is wrapped the hair is slightly twisted. The part of the hair which has been waved previously is allowed to fall free.

The strands coiled around the curlers are treated with a supersaturated saline solution in the form of paste. This saturated coiled portion of the hair is then inclosed in a wrapping and heated by encircling the coiled hair with a suitable heater.

A temperature of 800 degrees is maintained for about twenty minutes. Then the heat is turned off for four minutes, and turned on again for four minutes. After the hair has cooled it is taken out of the coils and washed.



The sirens of old may have been more alluring but certainly no more mysterious

The Lure of the Lorelei  
Minus the Siren

THE song of the sirens has long been stilled. The flowing deep has lost its sweet-voiced, seductive interpreters and the wild waves whisper enigmas. Instead, the voice of the saxophone, the bugle or the bass horn may be made to steal along the surface of the waters.

The principle of the invention which makes this possible is merely the submersion of a watertight compartment with vents for air and a horn or other vent connected, through which music may be sung or played for the amusement of an audience.

The water-tight compartment is a box of glass with a steel frame—or, it may be a leak-proof barrel with a superstructure for supporting the instrument. A block-and-tackle is attached so that it can be immersed and raised at will.

The idea presented is open to variation and many amusing effects might be obtained by the use of concealed vents in the place of the conspicuous horn which is shown in the illustration.



The saturated strands of hair are wrapped in flannel and heated twice by electricity

# Resuscitating the Drowned

## A first-aid tilting machine

**T**HE usual methods of reviving the apparently dead aim to aid respiration.

These methods produce a rhythmical filling of the chest with air. Unfortunately they require the aid of several well-trained attendants for a considerable time, and such aid may not always be at hand.

The apparatus shown in the accompanying illustrations, which is the invention of Dr. L. Lewin, of Germany, is said to attain the desired end with greater ease and certainty. It consists of an adjustable table or couch on which the person to be revived is placed and put through the different desired positions with the aid of only one attendant. The folding table is easily transported and is so constructed that the head or foot-end can be raised or lowered until it forms a decided angle with the horizontal position of the couch. The patient, say one to be revived from drowning, is strapped to the table by a bandage. By moving a pawl the head-end is lowered to an angle of ninety degrees with the horizontal, the patient being thus stood on his head. This causes the water collected in the lungs to flow out of the nose and mouth, both as a result of the law of gravity and also because the falling of the intestines drives the diaphragm forward and produces a strong compression of the chest. After a passive

breathing out has been produced during the ten to fifteen seconds

of this position the table is swung

towards the opposite side so that the patient is brought into a nearly upright position.

This change brings about an expansion of the chest, the result of its elasticity and the sinking into the natural position

of the intestines and diaphragm. Both of these movements can be repeated several times a minute, thus causing a succession of breathings in and out. In addition to this, if the heart action is poor the blood is driven to the different parts of the body by gravity in the changes of position.

### Nature and Not Cannons the Real Cause of Rainfall

**W**HYY does rain often follow great battles? Cannonading has nothing to do with it. The belief that rain commonly follows battles antedates the invention of gunpowder. In temperate latitudes rain occurs normally, on an average, every three or four days, or, in some regions, as often as every other day. The movements of troops that precede a battle are rendered difficult or impossible by wet weather and muddy roads. Hence the preliminaries of battle are carried out during intervals of fair weather.

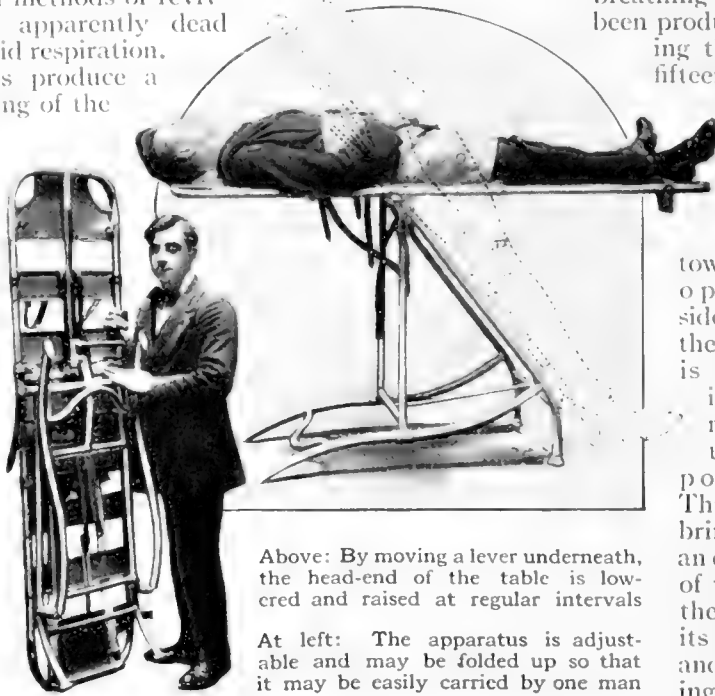

Above: By moving a lever underneath, the head-end of the table is lowered and raised at regular intervals

At left: The apparatus is adjustable and may be folded up so that it may be easily carried by one man



A man with a wrench opens the nozzles in succession, each stream cleaning to a line ahead of the next nozzle until the operator has gone over the entire area between hydrants

**Flushing Streets with Streams from Movable Pipe-Lines**

**D**IFFERING entirely from all previous types of street-flushing apparatus, a simple device recently put on the market consists of a jointed line of piping with valves at regular intervals, the whole being placed in the center of the street from hydrant and the flushing accomplished by turning on each nozzle in succession. The pipe line is made up of sixteen-foot sections, each mounted on two wheels at each end and connected with the next section by means of short lengths of rubber hose. Each unit has a swinging valve connection, which can be turned in any direction.

One end of the line is attached to the nearest street-hydrant.

**The Northern Logger Is the Nerviest of Our Steeplejacks**

**O**NE has only to go to the depths of the great wooded districts of Oregon and meet the logger in his native haunts to recognize in him all the qualities which go to make up a nery steeple-climber. He thinks nothing of doing an ordinary steeplejack's job before breakfast and then dogging falling trees and setting off dynamite blasts until the supper bell rings.

The accompanying photograph shows a logger in the act of oiling the blocks. He was hoisted to his dizzy position by a donkey engine, and as he sat there, straddling two thin steel cables, he was so much at home that he smoked his pipe. The large pole is a gin-pole, erected to lift the logs.



The lumberman calmly smokes his pipe as he oils the blocks at the top of the swaying pole

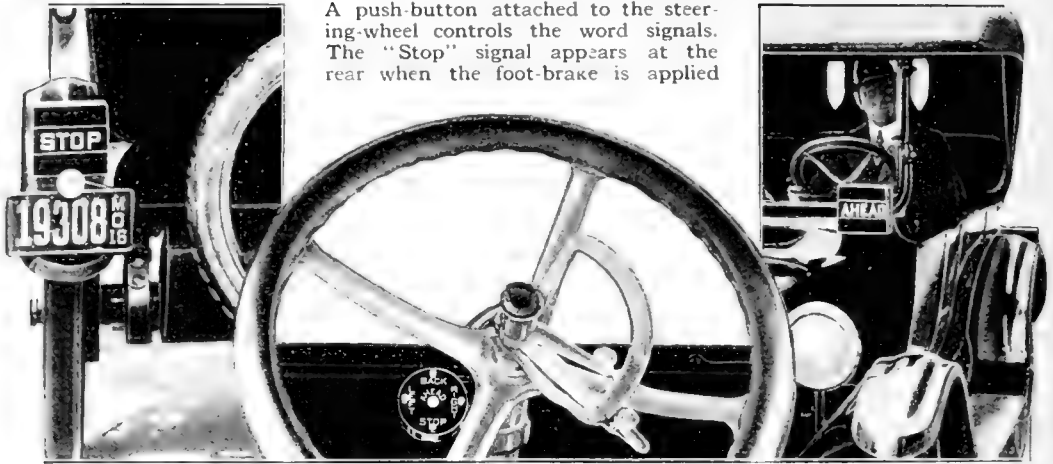

A push-button attached to the steering-wheel controls the word signals. The "Stop" signal appears at the rear when the foot-brake is applied

#### Automatic Word Signals for Automobiles

**D**IFFERING from other forms of traffic signals fitted on automobiles in that the direction the car is about to take is indicated at both front and rear and that words are used to denote these directions, the novel type shown in the accompanying illustrations consists of two metal boxes, one on the dash and the other at the rear above the registration plate. Each of these boxes contains an opening before which the words "Ahead," "Right," "Left," "Back" and "Stop" can be displayed at will by means of an electric push-button control attached to the steering-wheel. The words are cut into an endless roll in each box, the movement of the roll being electrically controlled and illuminated at night. The control has a button for each of the words used. The signal "Ahead" is always displayed to indicate that movement but is changed as desired by pushing one of the other buttons. The control buttons

are interlocking, so that only one signal can be shown at a time. The signal "Stop" is wired up to the foot-brake, so that it appears at the rear whenever the foot-brake is applied. It automatically disappears as soon as the foot-brake is released.

---

#### Lifting Invalids with a Minimum of Discomfort

**T**HE lifter illustrated is made a little wider than the ordinary hospital bed so that it may be placed, in position by being rolled up to the bed from the foot, the sides of the lifter just escaping the sides of the bed. It is an easy matter to place the supporting straps under the patient. When the straps are

secured the frame to which they are

attached may

be lifted by means

of a lever.

In handling

fever patients

who require

frequent

baths the

device is of

great service.

It may also

be used for

transporting

patients from

one room to

another.

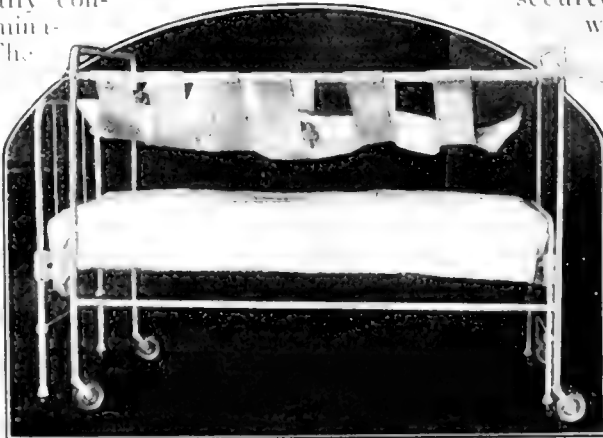

An invalid being raised from his bed by means of the mechanical lifter to allow a change of the linen

How a Tiny Screw Held Up a Great City's Business

A DIMINUTIVE screw worked loose in one of the big steel safes in the treasury department of Cincinnati recently, and dropped into the mechanism operating the combination. Thereafter there was trouble. The screw took its tumble on a Thursday night and it was not until the following Tuesday that the safe was opened. On Friday morning, when five hundred people were standing in line waiting for \$25,000 in pay envelopes reposing behind sixteen inches of steel, the paymaster discovered that something was wrong. He asked the people to wait until he found a Jimmy Valentine.

After several men who admitted that they knew uncanny things about opening safes were tested out, the big safe was just as obdurate as ever, and the line of watchful waiting ones was dismissed.

Friday night the safe was ordered drilled open. A crew of four men worked from that time until Tuesday morning before they undid the mischief caused by that one little screw when it dropped out of its allotted place. The additional work cost the city \$75, besides the patience of five hundred citizens.



The stud buttons clamped in place through the ear of the animal to be identified

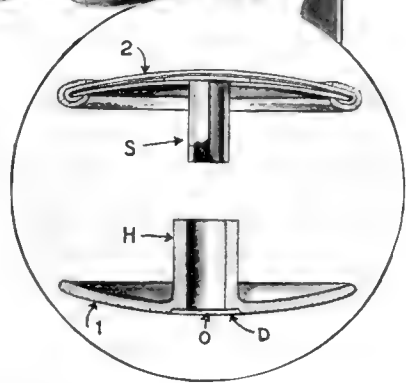

Detail of a simple type of clamp button showing the two parts separated

Branding Animals with a Clamp-Button Monogram

MARKING of animals for the purpose of identification has long been accomplished by means of the branding iron. The branding of stable stock, however, means a marred coat. A new method of marking with metal buttons offers several advantages. The buttons are clamped through the ear by means of a cylinder and split shank.

Animal stealing would be rendered unprofitable, for the removal of a button, or its defacement, would be extremely difficult. The detail drawing shows a simple type and design of clamp-button. The stud 1 has a short cylinder-sleeve H into which the split shank S of stud 2 passes—the long end of the shank projecting through cylinder-end O is spread outwardly by pincer pressure, the spread ends fitting neatly into the depression D in the surface of stud 1 thus clamping on the stud buttons.

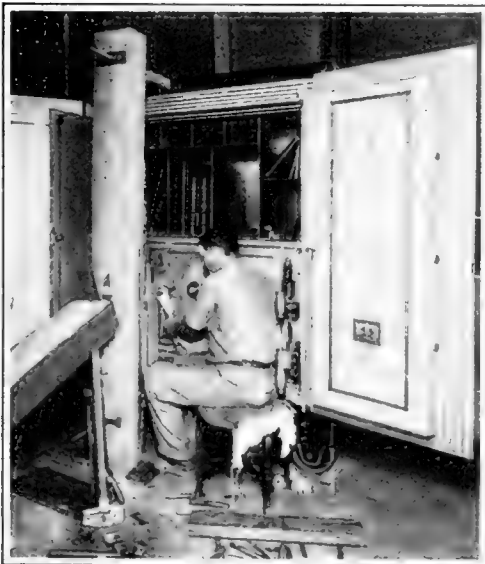

A screw fell into the combination of the safe and held up the Cincinnati treasury five days, defying skilled safe-openers





The native boys climb with the agility of monkeys, using their hands and feet

#### How West Indians Walk Up Coconut-Palm Trees

THE visitor to the West Indies often looks with longing at the great bunches of coconuts swinging at the summits of the lofty palm trees and quite out of reach of ordinary mortals. You may think that the natives wait until the nuts ripen and fall before gathering them, or you may remember childhood tales of petulant monkeys throwing the nuts at human beings below. But if you express a desire for a few coconuts and back up your request with a

few pennies, you will discover that the colored boys neither wait for the nuts to fall nor depend on monkeys to throw them down. Instead the nimble darkeys will climb up the smoothest and tallest trees to gather the nuts, for they are every bit the equals of monkeys in this respect.

Instead of "shinnying" up as northern boys climb our trees or hugging the trunk with arms and legs, the West Indian negroes actually *walk* up the trees. Claspng the smooth trunk with their hands and placing the soles of their feet against it they ascend the trees without the least difficulty and descend in the same manner.

So prehensile can the toes become that West Indian sailors climb ropes and rigging as they do palm trees; it is not an uncommon sight to see a black seaman walk up the polished mast of his sloop.

#### Manhole Ventilated with Electric Fan to Cool Men Below

WORKMEN employed in the conduits of a Los Angeles electric company are enabled to work in comfort while underground by the use of an electric fan for ventilation. The manhole is protected by a portable railed enclosure, to keep any careless motorist from driving into it, and at the base of the railing is set an ordinary electric fan, so arranged that the blades drive the air straight down. This affords a cool breeze that reaches the workman in the hot and stuffy cell below the pavement and adds a great deal to his comfort.

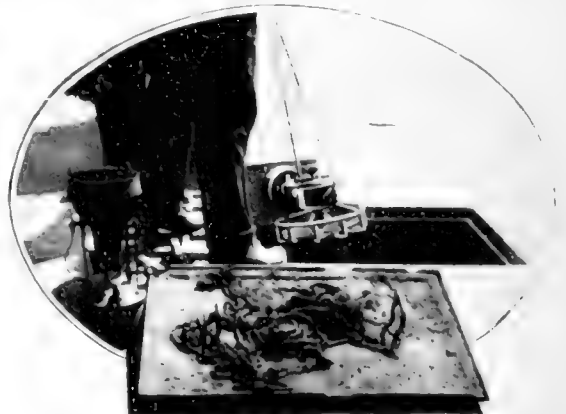

The blades of the electric fan suspended in the manhole drive the air currents straight down

# What Becomes of Old Army Rifles?

Instead of beating swords and guns into pruning-hooks and ploughshares, the Government sells them to motion-picture companies

**W**HENEVER the army and navy officials find that they have on hand a considerable quantity of supplies which for some reason are no longer usable, they condemn the equipment, arrange it in various lots, and call for sealed bids. These supplies usually include a great variety of articles ranging from corkscrews to cannons, from sailors' shirts to submarines, from a few hundred mess pans to millions of cartridges—a miscellaneous and heterogeneous stock, which only a daring man would buy and only a genius could utilize.

Methods of marketing army and navy goods are interesting. In the past, military schools have been among the largest consumers; but they must now give first place to motion-picture companies. There is practically no end to the usable material which these concerns can find in discarded government military paraphernalia.

Other kinds of equipment are transformed into useful and artistic objects. Coats of arms, hat and cap insignia, and other metal decorations placed

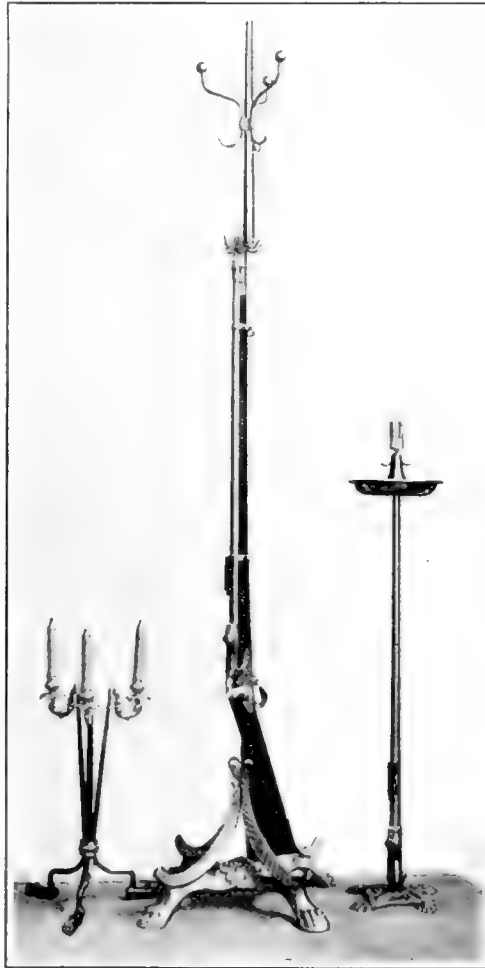

Swords, guns and bayonets are worked up into a variety of ornamental designs

on wood plaques make attractive curios. One hundred thousand helmet eagles have been used in this way. Bullets removed from cartridges and provided with proper bases are neat and serviceable paper weights. Short swords, cutlasses, etc., can be utilized as bread and meat knives. Ship lanterns fitted with electric connections make artistic hall, porch, and gate lamps. And swords, guns, and bayonets are worked up into a variety of pieces. The most pretentious of these are the three-light candelabra, the smoking-stand, and the hall tree illustrated. The candelabra is made of three bayonets gracefully curled and fastened together at the base and fitted at the top

with three candle-brackets. The staff of the smoking-stand is a nickel-plated rifle-barrel, while the base and the ash-tray are made out of belt-clasps, buckles, stirrup-cups, and other metal odds and ends all melted together and molded into artistic forms. The hall tree is a real work of art. By removing three screws the rifle can be released from the frame to be used again.

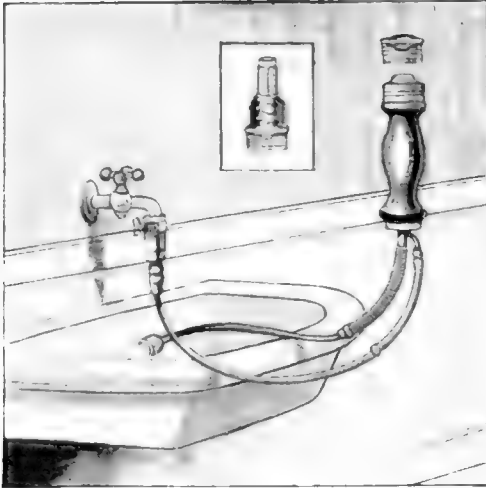

The current of water through the vibrator is interrupted ten times a second with this apparatus

#### Making the Water from a Faucet Vibrate Fifteen Times a Second

**I**F water from a water-supply conduit is introduced under pressure in the outer space, or tube, of a double cylinder perforated with fine holes at its rear end, the water is forced to flow out through the fine holes. If a rubber membrane is stretched across the holes it will vibrate because of the repeated upward pressure of the outflowing water and the alternate action of suction.

The illustration shows a vibration apparatus embodying the principle of an interrupter in which the stress transmitted upon the rubber membrane is obtained in a simple manner. In a metal screw-ring is a rubber membrane and below it is a rubber ring. When the metal ring is screwed upon the top part the rubber membrane is stretched across the cone, and on opening the water cock it is subjected to rapid vibrations. In case the vibrations of the membrane are to be transmitted to a piston, the ring is removed by unscrewing and a fixture is used instead. This consists of the same metal ring and in addition a piston held under tension by means of a spring in the cylinder. When the membrane is subjected to the up-and-down movement it pushes the piston upward. The piston is then

depressed by the spring and again driven upward by the membrane.

One peculiarity of the water-pressure interrupter is that in the expulsion of water ten to fifteen interruptions of the current occur every second, instead of a constant flow. For instance, if the out-flowing water is directed into a bottle the water current issuing jerkily will act more effectively in cleaning the bottle than would the ordinary flowing current of water.

#### Saving Gold and Silver on the Vacuum-Cleaner Principle

**S**TARTLING amounts of metal are removed from gold and silver articles by the simple work of polishing. In the case of jewelers who do much polishing work during a year, the loss in gold and silver is great.

A new form of polishing-machine aims to conserve the dust by means of a suction-fan mounted near the rapidly revolving brushes. The dust which flies off of the wheels is drawn down into a series of traps, from which it may later be removed and assayed for the pure metal.

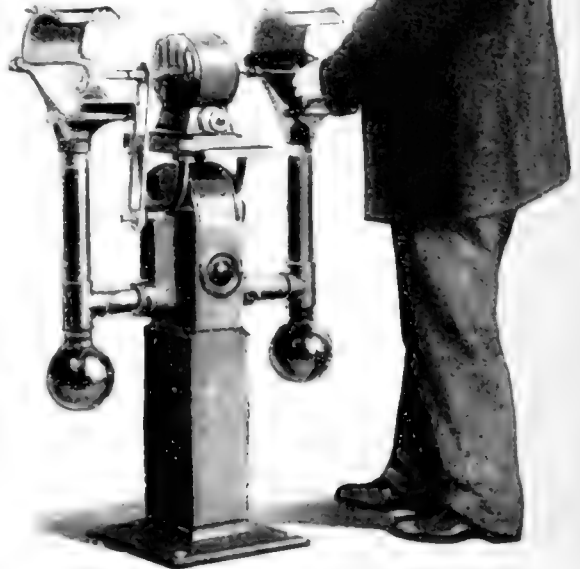

A suction-fan on a jeweler's polishing machine draws all the gold and silver dust into a trap

**A Pipe Filler Which Takes the Place of the Smoker's Fingers**

**T**HE fastidious smoker who does not wish to stain his fingers can stuff his pipe with an instrument invented by Arthur A. Hauerbach and Hugh G. Allan, of Stockton, California.

The stuffer measures a pipeful of tobacco in the tobacco-pouch or jar and then forces it into the bowl of the pipe without losing a particle. It consists of a tubular handle provided with a long slot near one end and a cylindrical bowl at the other. Within the bowl is a plunger which is fastened to a piston terminating in a finger at the top of the tubular handle, as shown in the accompanying illustration.

When the pipe is to be filled, the bowl-end of the stuffer is inserted into the jar of tobacco and turned until the bowl is packed tight. Then the stuffer is fitted into the bowl of the pipe. By pressing down the finger the plunger forces the tobacco into the pipe in a neat and compact mold. A spiral spring in the tubular handle instantly returns the various parts to their normal position when the mechanical finger is released.



The filler presses the tobacco into the pipe in a compact mold without staining the hands

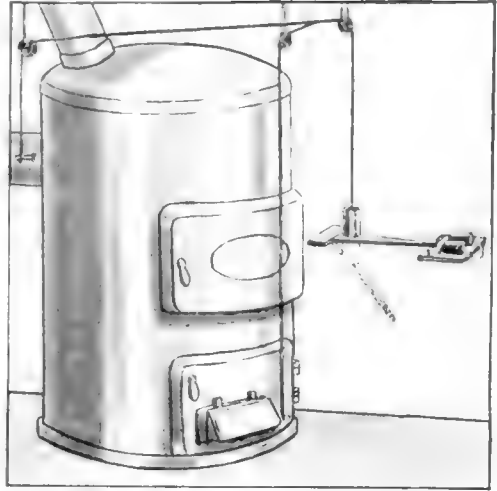

A weight supported by a strip of wood is attached to the damper and draughts

**Reducing the Furnace Man to a Mere Push-Button**

**F**ALLING down the cellar stairs in an attempt to get at the furnace to open the draughts on one of these blustering, cold mornings is not a wise or a necessary thing to do. By installing an apparatus such as is described here, you can stay in your warm bed and set the furnace to heating the house by merely pressing a push-button at your side. Or if you are given to over-sleeping, your alarm clock will perform the same service for you.

The apparatus for regulating the furnace consists of a weight attached by ropes to the damper and draughts, a light strip of wood to hold the weight, two magnets, an armature, and pulleys to lessen the rope-friction. The strip of wood which holds the weight is wide at one end and pointed at the other, as shown in the illustration. The pointed end rests on a heavy strip of soft iron which moves on two tin rails. When the push-button in the bedroom is pressed, a circuit is closed and the two magnets draw the piece of iron, or the armature, from under the supporting strip of wood, causing the weight to fall down and pull open the draughts.

An alarm clock may be used to take the place of the push-button. The clock can be set to complete a circuit at a certain hour and to open the furnace draughts in the way illustrated.



A glass of water may be heated almost instantly by immersing the cylinder in the water

#### A Magic Wand Which Changes Cold Water Into Hot Almost Instantly

**T**HE variety of uses to which the little immersion-heater shown in the illustration may be put will insure its popularity. It is a cylindrical tube about seven inches in length, having a flexible cord with a plug at the end which may be attached to any electric-light socket. Inside of the nickel case microhm resistance wire is wound about a mica coil, and when current is passed through this wire a white heat is obtained in a few seconds, so that it heats a small vessel of water almost instantaneously. The cylinder is immersed in the shaving mug, for instance, and in less than a minute the water is ready for use. A few seconds longer and it will boil. In warming the baby's bottle, however, it is best to heat a larger vessel of water, and set the covered bottle in it, which will take a little longer time. This special use will be most appreciated during the cold winter nights.

Other styles and sizes of the apparatus are also manufactured for physicians' use in sterilizing instruments and for kitchen use where greater quantities of water are needed for different purposes.

#### A Comfortable Electric Foot-Warmer Pad

**T**HOSE who are heir to all the ills resulting from cold feet will welcome an electric foot-warmer, recently put on the market. The heating coils form an oblong pad which is encased in a removable and washable eiderdown cover. A pair of soft slippers of easy fit are also provided. There is no reason why the pad may not be used to keep the feet warm while in bed also. It may be taken even into the automobile if arrangements can be made to connect it with the power. Wherever there is an electric lamp socket or the means of applying the current, the foot-warmer may be used.

Invalids, convalescents or anyone of low vitality will be sure to find it a comfort during the cold weather.



The heating coils form an oblong pad which is encased in a washable cover and connected with the lamp-socket

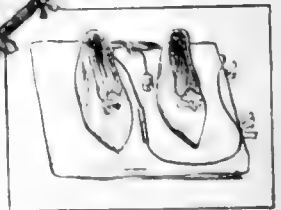

# Timing an Automobile Race

The Mechanism of the Judges' Stand

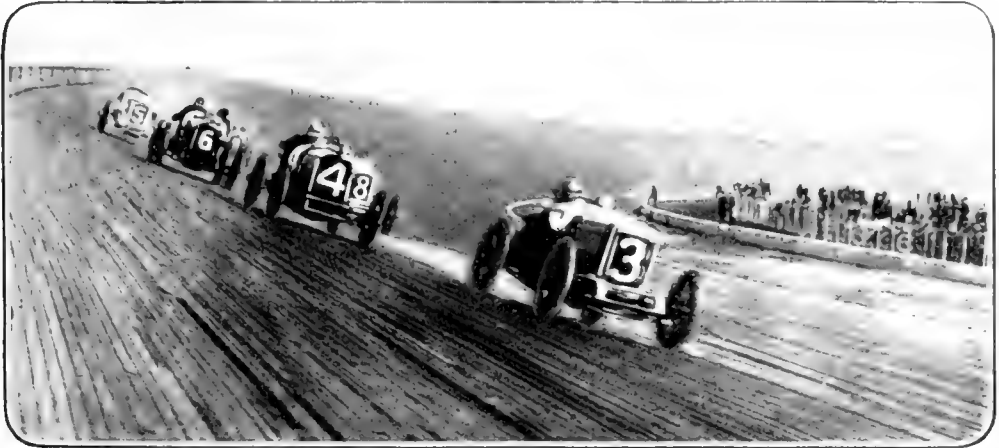

Here they come, snorting fire and skidding around the curve at a hundred miles an hour. At such speed, is it any wonder that the judges' records sometimes become confused?

WHEN twenty or more racing automobiles lined up for the start in the big speedway races during this summer and fall, Numbers 13 and 20 were missing. Number 13 was out because no driver will risk his life in a car with that ill-omened designation. Number 20 was omitted because of a mistake which occurred in the important Astor Cup race last year and which temporarily reversed the order of finish and almost resulted in the loss of \$1,500 to the misplaced racer. This error was made by misinterpreting the call 22 for cars 20 and 2.

Eight checks and double checks are necessary before the judges can decide the final positions of all of the contestants in a race. Few realize that at a maintained speed of 102.6 miles per hour, which was attained last year, the cars shoot by the judges' stand at the rate of approximately 150 feet per second. With seven or eight automobiles flashing by the stand almost simultaneously at that rate and across the finish line, less than one inch wide, it is easy to overlook one and make a costly error.

To obviate mistakes, the work of timing the cars is divided into four parts: 1—Getting Knowledge. 2—Checking Knowledge. 3—Calculating Knowledge, and 4—Dissemination of

Knowledge. The first division, Getting Knowledge, is the most important of the lot, because upon this knowledge, and the correctness of it, depends the accuracy of the checking, the calculation and the dissemination.

The entire group of timers is quartered on the upper floor of the judges' stand, generally inside the track, just opposite the finishing line.

The most important man in group No. 1 and the most important of the entire timing force is the caller. This man has nothing to do but to call off the number of each car as it passes him.

Directly in front of the caller are three men seated at the shelf or table as illustrated on the following page. Each of these men writes down the number of each car as called on blank sheets of paper torn from the pads and passed to a visor who compares them. If they tally, he then passes one along the desk to two men who mark the numbers down on the lap-sheet. This is a long piece of paper nailed to the desk and divided off into squares with the numbers of the cars at the left. Arranged along the top are squares, one for each lap of the race. As each slip bearing the numbers of the cars is passed to the two men in charge of the lap-sheet, they mark down opposite each car number its

# Timing an Automobile Race

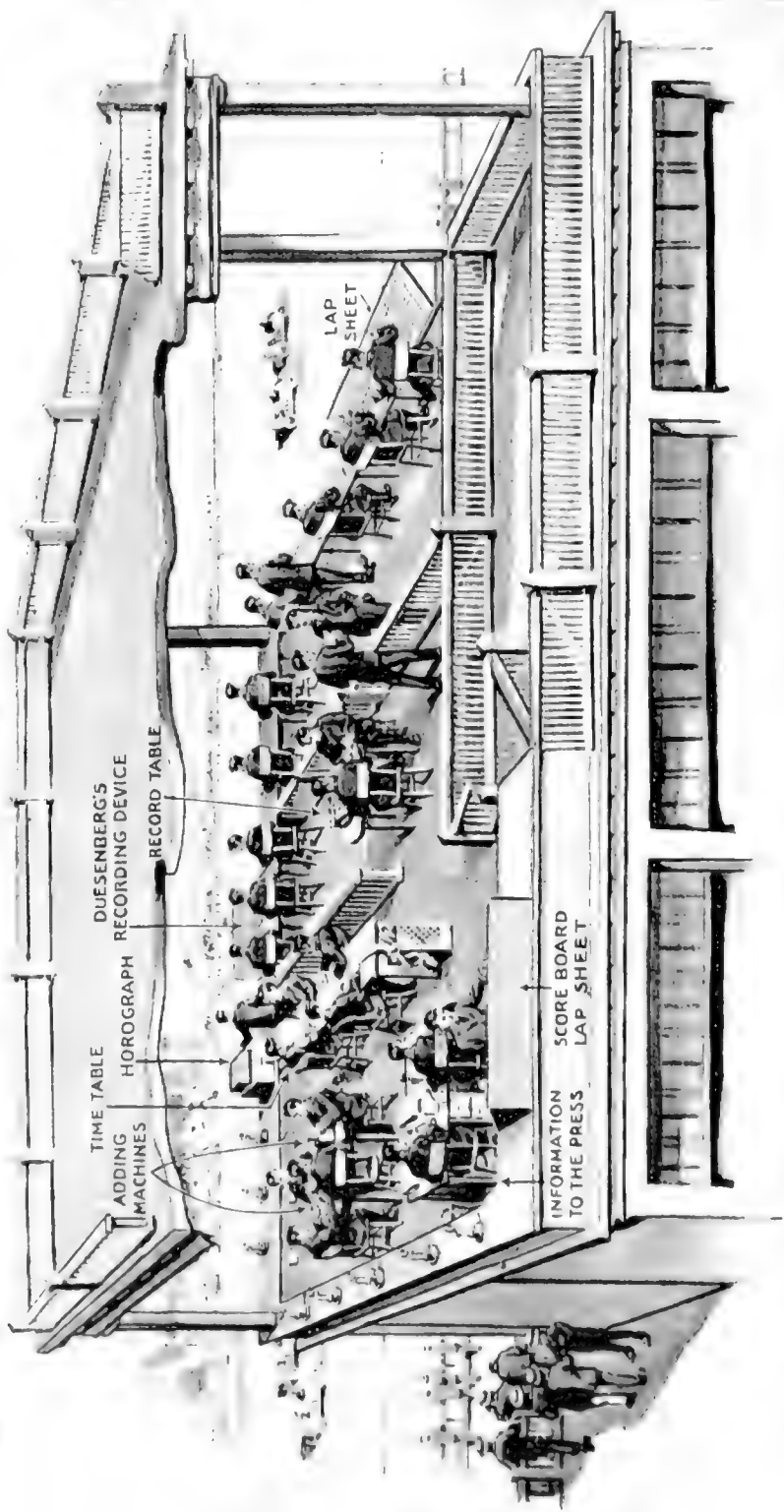

The timers are quartered in three divisions in the upper part of the judges' stand. In the first division, at the right, are those who get knowledge, in the second division, in the middle, are those who check knowledge, and in the third division, at the left, are those who calculate and disseminate it. The caller stands in the first division and announces the cars to the men in front of him. The numbers are then entered on the lap sheet, sixty seconds after each car completes a lap. In the second division are the checkers, registering the mileage of each car with *odometers*, and the record table, where reports are compared. In the third division are the horograph, which accurately times the cars; the adding machines, which calculate the speed in miles per hour, and the press or information table for newspaper men



position in one of the vertical columns allotted to the record for each lap.

This lap record shows the position of each car within 60 seconds after it has completed a lap, because not more than a dozen car numbers are written on any one sheet before it is torn off the pad and passed to the visor and in turn to the writers at the lap-sheet.

Group No. 2, Checking Knowledge, is made up of three men working two machines, one of which is a combination of odometers, one for each car. These odometers are used to register the mileage covered by each car, so that by dividing the reading as shown by the length of the track in miles, one can tell the number of laps credited to each car.

The other machine consists of two rolls of paper which automatically unwind at one end and wind up at the other by means of a crank attached to the odometer. That portion of the paper which is between the rolls is covered with celluloid except for a narrow slot which permits a thin slice of paper to show through. As the operators push down the odometer lever for any particular car, the man at the celluloid machine marks that number on the paper showing through the slot, and as the lever jumps back to its original position, the paper roll unwinds and brings a new strip of paper across the slot. The record thus obtained is used to check against the odometer readings and the lap-sheet.

The mechanism of Group No. 3, Calculating Knowledge, consists of an instrument known as the Horograph. This is somewhat similar to the apparatus used on the railroads for notifying a switchman that a train is coming by the ringing of a bell as soon as it has passed over a distant section of track. Electric wires are strung from the Horograph to the finish line on the track and as each car passes over them, an electrical contact is made which actuates a clock device forming a part of the apparatus so that the

time of contact is automatically printed on a long strip of paper tape, similar to that used on stock tickers. This tape feeds out of the machine along a narrow table, as shown in the illustration opposite, where it may be examined without being picked up.

Although the time when each car passes the finish line on each lap is printed on the tape, the particular number of each car is not designated, so that some means has to be taken to connect the time as shown with the car which makes it. This is done by men stationed along the table who watch the cars as they pass and then mark the proper number opposite each time record.

Two men stationed along this table take the time records from the tape as it passes them and mark them on special ruled sheets and then pass the sheets to the round table which is shown adjacent to the tape bench in the drawing opposite, where two men operating adding machines calculate the speed in miles per hour and reckon special lap speeds, for which prizes are awarded.

Directly behind the calculators' table is another which gives information to the press and announces the winners to those not in the stand. This is in Group No. 4, Dissemination of Knowledge. There is also another lap-sheet for giving information to the scoreboard and the grandstands. Many telephones are provided for sending or getting information from the pits.

#### Backing an Automobile into a Moving Garage



It requires deft manipulation to get the automobile fitted into the garage

THE illustration shows a puzzle recently placed on the market. In a glass-covered circular box two movable objects are enclosed. They represent an automobile and a garage, and the object is to get them dovetailed into each other. The floor of the box is of polished wood, which makes the task more difficult.

# The Electric Thief-Catcher

It rings a bell, takes a photograph of a burglar,  
and shoots him as soon as it sees his flashlight

By B. F. Miessner

ALTHOUGH this apparatus accomplishes some startling results, the idea of selenium-actuated burglar alarms is not altogether new. M. Dafah, a French engineer at Jansac, suggested the use of selenium for this purpose several years ago; others have worked along similar lines.

It may be mentioned here that no attempt has been made to obtain patents on this apparatus; its use is unrestricted, and any one with the inclination may copy this arrangement for his own use or pleasure.

But what is this Electric Thief-Catcher? How can any machine or electro-mechanical contrivance *catch* a thief?

In the first place it does not catch him, if by catch is meant to pursue and seize, and perhaps to march him to the patrol wagon or police station. If by catching is meant to trap, then we may safely say that it does exactly that, and it can be made to do it as effectively as you please. The writer very narrowly escaped being quite effectively caught, when on one occasion this apparatus sent a thirty-two caliber bullet through his coat-sleeve!

By "as effectively as you please" is meant that the "catching" can be varied all the way from merely sending in an alarm, to frightening the intruder away, or actually shooting him dead.

All that is required of the burglar is that he possess a light of some kind, if it be only a match or a pocket flashlight, and that its rays fall upon the acute and ever wakeful eye of this hidden apparatus.

This electrical eye is a selenium cell such as is shown in one of the accompanying illustrations. All that it can do is to record its impressions by sending an impulse to the electro-mechanical brain of the apparatus, when stimulated by a light. That impulse is a surge of electric current when the resistance of

the cell drops, due to the effect of the light. The cause of this curious effect is not yet understood but is being investigated by several men, among whom is Professor F. C. Brown, of the Iowa State University.

The brain is a sensitive relay, preferably one such as is used in the Electric Dog, which was described in the March number of *Popular Science Monthly*. This brain has the power to stimulate any one or any number of a great variety of electro-mechanical muscles, and to produce a corresponding variety of actions. In the writer's apparatus one of these was an electric gong, the burglar alarm; another an ordinary revolver whose trigger was pulled by an electromagnet; a third was a camera whose shutter was opened by a cord attached to the same electromagnet; a fourth, a charge of flashlight powder, which was set off by the heating of a short piece of fine resistance wire; and on one occasion a fifth was a phonograph with a specially prepared record, which, without a doubt would frighten out of his wits the boldest thief who heard its weird and uncanny warning.

Here, then, we have an electro-mechanical creature, which, hidden from all view, and with no human agency, will fire a revolver, send in an alarm, set off a charge of flash powder, and take the photograph of any marauder who prowls about with a light.

During the course of a lecture before the Chicago Electric Club and the National Electric Light Association, the author in the guise of the burglar stepped up to the platform in the darkened lecture hall, flashlight in hand; the instant the light fell upon the eye, the revolver began firing, the bell rang, the camera-shutter opened, the flashlight powder exploded, and the photograph on the following page resulted. In another lecture a phonograph was used and for five minutes there was enacted the

## Shot by His Own Flashlight



The burglar breaks open the desk and flashes his light upon the contents of a drawer. "Bang!" goes a revolver aimed at him from inside the desk. Simultaneously a bell is rung which awakens the household and sends in an alarm to the police station.

invisible, but by no means silent drama which might follow such a catch in a home. The cursing of the burglar, the screams of hysterical women and crying children, the excited father, and a "drag-him-out-by-the-police-finale" were plainly heard.

The principal parts of the apparatus, which we have called the eye and the brain, are a selenium cell and a sensitive relay; the nervous energy is supplied by a battery of cells, which are connected in series with them as shown in the upper diagram. If only an alarm is desired, an electric bell and battery may be connected to the local circuit terminals of the sensitive relay. This bell will ring instantly when a light strikes the selenium cell, and will continue ringing as long as the cell is illuminated. It may be placed in a sleeping apartment at a distance from the room to be protected, so that the burglar will be unaware of the fact that his light has sent in an alarm. A device of this nature would be valuable for the protection of vaults.

The selenium cells may be purchased from scientific supply houses at a cost of about five dollars each. The relay should be as sensitive as possible; a good polarized relay may suffice but a galvanometer relay is preferable.

The battery should consist of a sufficient number of dry cells (these may be of the small flashlight type) to nearly cause the closing of the relay contacts when the selenium cell is in the dark, and when the back spring of the relay is in sufficient tension to prevent sticking of the contacts after the light rays are obstructed. When the cell is illumina-

ted the relay should close promptly, and when the light is removed the back spring should pull the contacts apart without hesitation. In general the larger the number of batteries the more sensitive will the apparatus be, but with ordinary selenium cells the normal current should not exceed a few thousandths of an ampere. If the current is too large the temperature of the cell

may rise to the point at which selenium begins to melt; this will destroy the usefulness of the cell.

From the relay, acting as the brain, we may lead connections to whatever apparatus we desire to be actuated when the selenium cell is stimulated by light.

When several pieces of apparatus are to be set off simultaneously, for example the apparatus before described, a connection arrangement, such as that shown in the diagram, should be used. One hundred and ten volts are suggested since this is the voltage of most lighting systems, and because a solenoid sufficiently large to pull the trigger of a revolver will operate best on that voltage without additional apparatus, such as storage batteries. Where several pieces of apparatus are thus controlled it is necessary to use an auxiliary relay, due to the delicacy of the sensitive

relay, which cannot break currents in excess of a few fractions of an ampere. An ordinary pony relay of twenty ohms resistance is suitable for this purpose. If the arcing across its local circuit contacts is excessive a condenser connected in parallel with them will be found advantageous. The contacts should be set well apart and considerable tension put in the back spring to counteract the tendency to stick. Re-

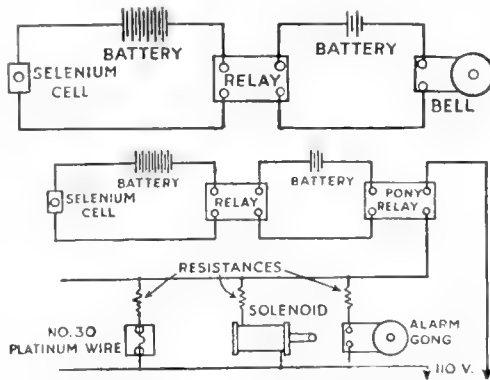

Above: The dry cells connected in series.  
Below: The plan of the connections when several pieces are to be set off simultaneously

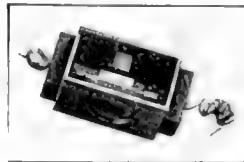

The selenium cell is the eye of the creature which when illuminated contacts the relay

sistances are shown in the separate circuits for the purpose of regulating the current.

If the mechanisms to be controlled do not require so much power a low voltage battery circuit may be used instead of the lighting circuit. The resistance of the flashlight wire should be low enough to permit of its heating to a red hot temperature when the current is switched on. To prevent this wire from acting as a short circuit on the other apparatus it should be small enough in size to actually fuse and break its circuit; ordinary fuse wire is not very suitable for this purpose, but fine strands of copper wire may be used in the absence of resistance wire. The charge of flashlight powder should explode within the one second during which the camera-shutter is open.

All of this apparatus may be installed in some hidden container such as a drawer of a desk, or of a chiffonier, or in a recess in a wall.

The selenium cell may be protected from the room lights by so arranging a contact on the lighting switch that, when the room lights are turned on, the power circuit of the apparatus is opened. This will prevent the setting off of the apparatus when the room lights are in use, but will in no way impair its effectiveness in the case of another light when the room lights are switched off. The apparatus may be protected from daylight by some simple form of time switch. A switch of this kind can be improvised easily from an old alarm clock, by fitting the clock with a circular conducting plate which will come into contact with the hour hand during a designated portion of the night. Should it be desired to

leave the apparatus untouched for longer periods of time, clockwork mechanisms, which will run for the desired period of time, may be used. The revolution of a contact arm once in each twenty-four hours is necessary. A contact arm can be arranged which would cause the thief-catcher circuit to be opened say from five A. M. to seven P. M., or during the daylight hours. Another variation would be to utilize a second selenium cell well-exposed to daylight, which, when illuminated, would cut out the thief-catcher apparatus, by operating a relay connected to a break switch. Such an apparatus would be simple in mechanism and should offer no difficulties to the experimenter.

#### Field Photograph Kit for the Use of the Artillery

A FEW years ago the Signal Corps undertook the task of developing a photographic outfit that could be carried with a mobile army. After much experimenting a field telephoto equipment was designed which contained everything necessary for developing and printing negatives taken in the field by scouts.

A machine was obtained for projecting lantern-slides in a wall-tent, so that the commanding general could see on a large scale the surrounding country, etc. The telephoto-camera has proved somewhat useful in photographing the location of shots in field artillery work. When set up for developing and printing the kit resembles a suitcase on tripods. Two windows are provided. One admits red light for developing and the other white light for printing. The kit has not yet been adopted as a unit of army equipment.



A machine for developing and printing negatives taken in the field by scouts

### A Show-Window Advertising Device Operated by Gas Bubbles

THE device illustrated is based on the movement of a body caused by electrolytic action. In a glass tank of liquid is placed a celluloid or other disk which floats upright. On its top is a small bell-shaped body of any material. A metal plate is mounted at the middle of the disk and a wire leads down from it and projects below the disk. The end of the wire dips into mercury at the bottom of the tank, and thus makes electric contact so that an electrolytic action is set up.

The metal plate is attacked by the

acidulated water of the tank, gas coming off from the plate and rising so as to fill the small bell.

The gas contained in the bell increases the buoyancy of the float and causes it to rise to the top of the tank, where the gas escapes out of a fine tube at the top of the bell. The gas could not escape at the bottom due to capillary action, but at the top of the tank the end of the tube comes against blotting paper and the gas escapes because the capillary effect

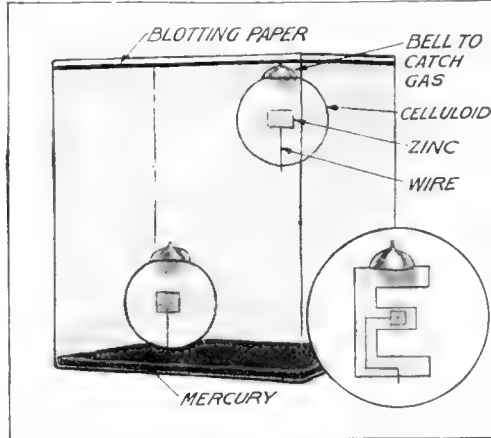

The disk rises to the top of the tank where the gas escapes, causing the disk to sink

at the end of the tube is destroyed. When the gas escapes the float descends again to the bottom of the tank, and the action is repeated. An advertisement can be put on the disk, or letters can be used.

## Money Prizes for Motorcyclists Send In Your Kinks

IF you are a motorcyclist, if you have devised simple ways of making repairs, if you have improved your machine in any way, this will interest you.

The POPULAR SCIENCE MONTHLY offers a first prize of \$25, a second prize of \$15 and a third prize of \$10 for articles in which motorcyclists will describe and illustrate the methods which they have successfully employed for overcoming trouble, for making quick repairs by the roadside or more difficult repairs in the shop, or for making attachments broadening the use of the motorcycle.

The three prizes will be awarded by the editors of the POPULAR SCIENCE MONTHLY in the order of merit. What is more, even though your article may not win a prize, the editors may buy it at the usual rates, just because it is so good.

There are no limitations to this prize offer. We don't care for fine phrasing, but for mechanical ideas. Rough pencil drawings or photographs will do for illustrations.

Observe these conditions:

- (1) Articles must be written on one side of the sheet only.
- (2) Write your name and address in the upper right-hand corner of the first sheet.
- (3) Enclose postage for the return of the manuscript.
- (4) Don't send in articles on ideas which have already been published.
- (5) Don't send paper ideas—things that you haven't actually done yourself.
- (6) Address the envelopes containing articles to

"Motorcycle Contest Editor"

POPULAR SCIENCE MONTHLY  
239 Fourth Ave., New York City

The contest will close on December 31, 1916.



# For Practical Workers

## A Foot-Warmer Attachment for a Radiator

THE fact that air currents pass up through the sections of a steam or hot water radiator so that the heat rises before dispersing throughout the room accounts for the floor under the radiator being a poor place to warm the feet. The shelf arrangement shown in the illustration will be found very convenient for supporting the feet at a comfortable height near the side of the radiator close to the heat.

The device is made of a board 15 in. long and 6 in. wide, with two rods attached, having their upper ends bent into long hooks to engage the connections between the sections of the radiator at the top. This makes it easy to remove the attachment when not required. It may also be used as a shelf on which to set articles to keep them warm.—A. E. HOLADAY.



A shelf supported by long hooks attached to radiator connections for a foot-warmer

## How Electricity and Temperature Affect a Watch

EVERY second counts—it counts half a revolution of the balance wheel of your watch, 1,800 revolutions an hour; so, anything that will affect that 12-in. coiled spring that governs the escapement may make you miss your train—or make your train miss its signals and safety.

The effects of varying temperatures have been compensated for even in watches that need not be very accurate,

and especially in carefully designed time-pieces. The effects of magnetism are also considered, the influence of which has been minimized in the last few years because of the development of electric generators. But watches still are liable to impairment from electrical influence, even in the slight amount of static electricity created by the friction of steel wheels on steel rails when a train or car starts or stops suddenly.

A simple experiment, showing how a watch may be magnetized without actual contact with the magnetizing source, may be conducted with paper, some steel filings and an ordinary magnet. The magnetic field will be indicated by the lines of force in which the steel filings will arrange

themselves when the magnet is held under the paper. With a magnetizing source more powerful and its extent of influence proportionately greater, it may be readily seen how the steel in the watch may be magnetized—the steel parts, of course, retaining the magnetism, which, as the parts of the watch assume various relative positions in moving, causes them to be affected so that they are retarded or accelerated.

Whereas a watch in perfect working condition may be adjusted to vary only an average of .23 seconds daily, a magnetized watch will vary from 1 to 125 seconds an hour. Of course a watch may be demagnetized, but it



cannot be made immune. Watches are being constructed now with non-magnetic alloys in place of steel; but the alloys are not perfectly satisfactory.

The effects of temperature are taken care of more easily. The impairment of the hair-spring function is compensated for by the construction of the balance wheel, which has a rim of fused brass and steel. Each metal re-acting in differing degree to temperature, the variance in its contraction or expansion under the influence of cold or heat produces a bending of the rim, formed by two half-circle arcs. These are arranged and constructed so that the variation in the balance wheel will compensate for the variation in the hair-spring.

Many have wondered what is the purpose of the little screws on the edge of the balance-wheel rim. They are to give the wheel the exact weight, by their adjusted arrangement, to make the proper number of revolutions and to make even more accurate the balance wheel's compensation for variation in the action of the hair-spring under temperature effects. When heat weakens the spring, it reduces the diameter of the balance wheel to correspond exactly for compensation.

### A Combination Tool With Many Uses

A VERY handy tool can be made from tool steel 14 in. long, 3 in. wide and  $\frac{1}{4}$  in. thick. The teeth in the part *A* can be made with a three-cornered or half round file. A hole is drilled near the edge and the metal filed to shape as shown at *B* to make a bottle-opener. The hole *C* is used as a universal nut-

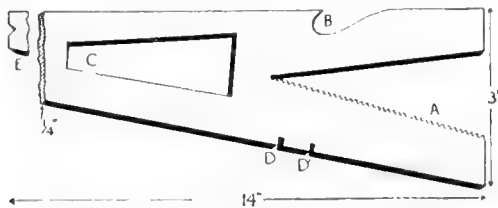

A combination bottle-opener, nut-wrench, saw-set, screw-driver and tack-puller

wrench. Two slits are cut in the edge at *D* to make a saw-set. The end *E* is filed to make a tack-puller.

### Marking Points to Bore Holes for Dowels

DOWEL joints must be exact. A good method for marking simultaneously in both pieces is shown in the drawing. A piece of tin or thin sheet metal is cut to convenient size and a bit of wire inserted in the exact center and

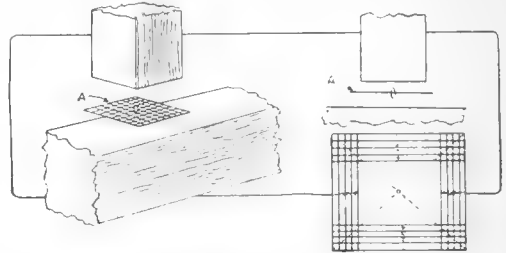

Marker to locate points for boring holes simultaneously in dowels to make neat joints

soldered, so that a part of it will project on each side of the sheet. To locate the center of the metal, draw cross lines diagonally from the corners. The point where the lines cross will be the exact center.

A more elaborate marker, large enough for all work, can be made from sheet brass or copper, with lines drawn parallel to each other, beginning at each side,  $\frac{1}{8}$  or  $\frac{1}{4}$  inch apart. These lines should be numbered, starting with 1 from the outside edge and finishing near the center. When placed on the end of a square or rectangular piece the center can be located with these lines and numbers.

Place the marker on the end of the piece; then set it in the exact place on the other piece of wood and strike it. The pin points will mark both pieces.

### Painting a Ladderless Standpipe

PAINTING a ladderless standpipe proved to be too great a problem for several contractors, but it was solved by an old painter. He found out how long it would take to fill the pipe, and then had it emptied. He took several large timbers inside and built a raft, after which he ordered the doors closed and the pipe filled. By the time the inflowing water had borne his raft to the top, he had accomplished his purpose. — HAROLD HORINE.

### To Keep the Water in the Aquarium Clean and Fresh

AN aquarium for the home may be equipped with a simple contrivance for keeping the water clear and fresh, thus overcoming the only difficulty in maintaining one. The aerator shown works simply and will go for months without other attention than to provide water for the supply basin.

In the drawing showing the apparatus there are the fish tank, supply basin, and glass tubing from the basin to the tank. The siphon forces a supply of air through the water in the fish tank. The tank consists of a baseboard which is slightly larger than the tank itself, four square posts and four pieces of heavy glass. The base piece should be cut from wood 1 in. thick. Screw two strips of wood across it on the under side, one at each end, to prevent it from warping.

The corner posts are to be shaped as shown in the drawing with a rebate for the glass on the adjacent sides and a piece fitted in the inner angle to hold the glass in position. The base is also grooved on the sides and ends for the glass. Fit the posts by sinking them into a  $\frac{1}{4}$ -in. mortise cut in the base piece and then put a long screw into the end of the post through the base piece.

In fitting the glass bed in place use white lead putty made up with a little powdered rosin to cause it to harden quickly. The wood of the tank should be varnished and allowed to stand for one week before the tank is filled.

The aerating apparatus is made from  $\frac{1}{4}$ -in. glass tubing with a piece of  $\frac{3}{4}$ -in. tube for the air-receiver and two corks.

The  $\frac{3}{4}$ -in. glass tube is 7 in. long and is fitted with a perforated cork at each end. A hole about  $\frac{1}{8}$  in. in diameter is filed in the side of the glass.

Fit the  $\frac{1}{4}$ -in. pieces of tube through the corks, one at each end. Take the lower piece, which should be about  $3\frac{1}{2}$  ft. long, heat one end of it and form into a slightly bell-mouthed shape.

The lower end is also heated and bent as shown in the illustration.

The upper piece of glass, which should be of a convenient length, is bent in the form of a syphon. For the supply basin use a glass jar.

After all the parts of the aerating apparatus have been fitted together, fill the fish tank and put the aerator in position; fill the supply basin also nearly to the top with clear water.

The upper part of the  $\frac{1}{4}$ -in. glass tubing is now taken out of the cork, and filled with water, holding a finger on each end. Then slip one end of the tube into the supply basin and the other through the cork of the air-receiver.

If this is correctly done, it will be found that the water begins at once to drop from the upper pipe, taking its supply from the basin on the wall

bracket, and before very long it will be forcing a supply of air through the water in the tank at regular intervals. —JOHN Y. DUNLOP.

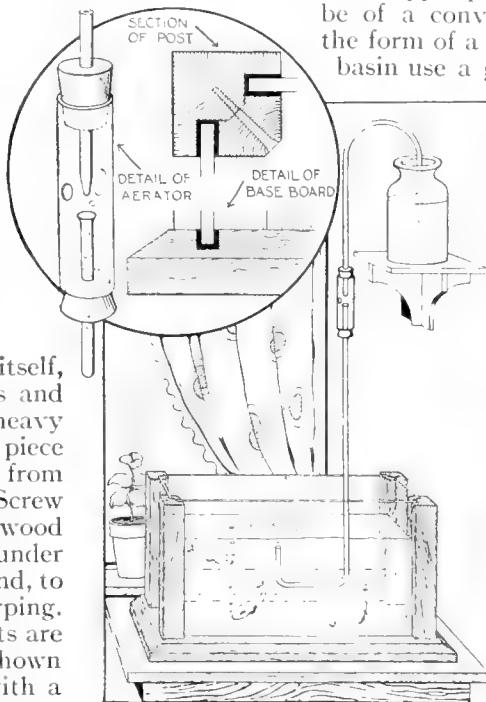

An aquarium with an automatic supply basin and an aerator.

### Making a Serviceable Fireless Cooker

THE cooker illustrated on the following page can be made with two or more pots, although the drawing shows only one. The outer part of a double boiler will serve for the pot. The first requirement is a stout box of suitable size, with the cover hinged. To prevent warping, it should be reinforced with

two braces. It is held down securely by two catches in line with the braces.

The upper part of the box is filled with a rectangular pad of felt stuffed tightly with hay. This is removable.

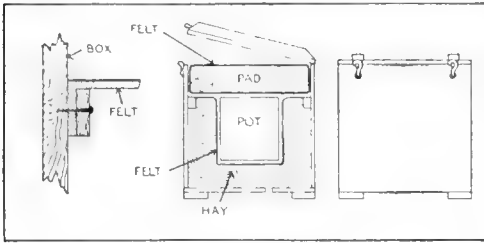

A felt-and-hay insulated fireless cooker to accommodate one or more pots as desired

The pot is completely wrapped about its sides and bottom with a felt overcoat. This may be made from an old felt hat which, if thoroughly steamed, may be easily shaped about the pot. If it is not wide enough to reach to the sides of the box, the erstwhile brim should be sewed to a square piece of stout material in which a circular hole has been cut. This rectangular piece is attached to the sides of the box by means of a  $\frac{1}{2}$ -in. wood molding, as shown in the sketch. The final packing of the cooker is done as follows:

The bottom of the box is temporarily removed. The cover is lifted and over the pot the rectangular pad is placed. The lid is closed and the box turned upside down. Then the space that remains is filled with firmly packed hay, and when the bulk of this is in place all but one of the bottom boards are nailed down. Through the remaining opening more hay is crowded in until the packing is perfectly solid. Then the last of the bottom boards is secured. As a result of this arrangement the cooker is insulated at the top, sides and bottom by at least  $2\frac{1}{2}$  in. (preferably 3 in.) of packing. This prevents radiation and insures the efficient use of all the heat which will be stored in the pot.

ROBERT G. SKERRETT.

#### Loosening a Wood Screw to Draw It Easily

**I**N an effort to remove a No. 18 wood screw which is 2 in. long, the slot in the head was put into such a

condition that the screwdriver-bit would not engage it. The screw had rusted in the hole. A cold chisel and hammer were brought into use to cut another slot. After cutting the slot it was found that the screw came out very easily. The force of the hammer blows had loosened up the rust and also had spread the wood around the screw sufficiently to allow it to come out. The same operation was tried out on a screw which had the head entirely twisted off, and it was easily removed.

#### Transforming a Wheelbarrow into a Fantastic Toy

**A**N example of how so prosaic a thing as a wheelbarrow may be made into a most alluring toy is shown in the illustration. As his clownship calls for grotesque rather than artistic lines, anyone handy with a saw and a sharp knife can fashion such a barrow according to his own ideas. The one pictured is in eleven sections—two legs, two sides, two end-pieces, the bottom, side standards, front wheel and head, which is carved on both sides.



The parts of the wheelbarrow are cut out in the shape of a clown and decorated

First, roughly sketch the clown on heavy manila paper in order to familiarize yourself with the lines of his anatomy; then boldly draw six sections on bristol board, half of his figure sufficing for a pattern. Cut out these sections with a sharp, pointed knife indicating with a pencil what each one is. Any lumber will do for the barrow; even an ordinary pine box may be utilized if it is long enough to provide handles, the dimensions of which may vary according to the size required. The proportions of the figure shown are about as follows: leg, 30 in. to tip of toe; end-piece, 14 in.; side-piece, 27 in.; standard, 12 in.; wheel, 10 in. in diameter; head, 9 in. from the crown to nape

of neck. The shoes are carved on the limbs and painted red.

The queer handles have carved grooves that slip into the end of the side-pieces on the order of the old-fashioned wooden bedsteads. The wooden standards are "square pegs in square holes," and serve as rests for the barrow. They have an extension running up on the inside of the barrow, where they are bolted in place. The wood selected for the front wheel should be at least  $1\frac{1}{2}$  in. thick in order to afford stability. The sides are sawed in such a shape that the iron rod from the wheel passes through the center of his clownship's palm where it is secured with screws.



The sidecar as it is attached to a bicycle

placed 15 in. above the frame, which is used for supporting the seat and also as a means of attachment for band-iron braces to the bicycle. Screws should be used throughout for fastening the boards to the frame and rails. First fasten them to the side rails, then draw the curved line at the top and cut both sides out at the same time after clamping them together. Before fastening them permanently to the frame, lay a floor of  $\frac{3}{4}$ -in. boards. A single board 16 in. long placed on the side rails makes the seat. The back is put on in the same way as the sides.

The side wheel, which is an ordinary front bicycle wheel, is attached to the body of the sidecar with braces of band-iron  $1\frac{1}{8}$  in. wide and  $\frac{3}{16}$  in. thick, the forward one being fastened over the side rail and the other to the upper rear part of the body. The inside end of the hub-axle is supported by a piece of the same band-iron shaped as shown at *B* and bolted over the side boards to the frame back of it.

### Constructing a Sidecar for a Bicycle or Motorcycle

THE accompanying illustration shows the construction of a simple sidecar for a bicycle, which may be enlarged for motorcycle use. The frame of the sidecar should be strong, light and well made. Basswood will be found very durable for a light sidecar for a bicycle. The joints at the corners are lapped with a small bolt run through them to hold the parts tightly together as at *A*. The frame is rectangular, 30 in. long and 16 in. wide, made of pieces  $1\frac{3}{4}$  in. wide and  $\frac{7}{8}$  in. thick.

The sides of the body are built up of  $\frac{1}{2}$ -in. boards fastened vertically to the frame, and a side rail

The same sized band-iron is used for attaching the sidecar to the bicycle, one piece connecting the body to the bicycle frame between the large sprocket and the small one, and the other between the side rail of the body, through the boards to the tube connecting the seat and the rear-wheel hub. This is shown in *C* and *D*. The bars of the last attachment must be twisted slightly, as the drawing shows, to allow for the slant of the bicycle tube.

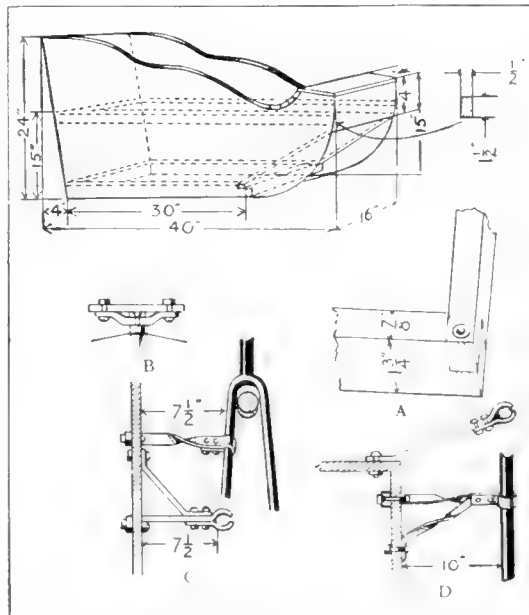

Details of the frame of a sidecar and its connections to a bicycle or motorcycle

### An Improved Grinder for Gas-Engine Valves

AFTER a gas-engine has been used for a time, the valves, especially the exhaust members, are apt to become pitted and scored. In some cases, this

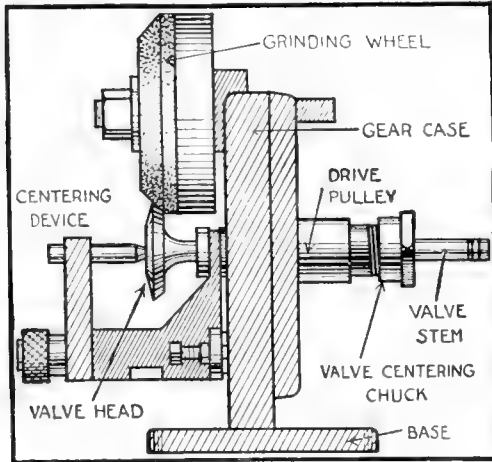

An abrasive wheel supported on a ball bearing shaft for valve-grinding purposes

roughening is so pronounced that it is almost impossible to grind the valves into a correct seating by the usual emery-and-oil process. The valve grinding will be considerably facilitated if the valve-heads are surfaced off.

An improved grinder for this purpose, recently marketed, is shown in the accompanying drawing. An abrasive wheel is supported on a ball-bearing shaft driven by encased gearing in such a way that its speed is fourteen times that of the valve-head and its direction of rotation opposite. The valve is carried by an automatic, adjustable rotating chuck which insures that the valve will be properly centered, this being driven by a small pulley from any available power.

The abrasive wheel is properly beveled to make sure that the angularity of the valve-head will not be changed. A centering device is included to exert pressure on the valve-head and bring it in contact with the wheel. An integral wheel-dresser is also a part of the device. The tool shown has a capacity for valve-stems from  $\frac{5}{16}$  in. to  $\frac{1}{2}$  in. in diameter and valve-heads from  $1\frac{1}{2}$  to 3 in., this range taking in most of the valve sizes in automobile engines.

### A Fire-and-Water Proof Cement for Mending Stove Fire-Brick

HERE is a formula for a cement which will repair fire-brick in stoves and furnaces, and which can be used even where there is an intense heat. Take 3 parts of fire clay and 1 part iron filings and mix with strong vinegar until a putty-like mass is formed. If the cement is used to fill up very small cracks and crevices, it should be thinner. If iron filings cannot be secured, fine iron borings will be just as good. If it is desired to use the cement in a furnace for melting metals, the following mixture will give better results: 1 part iron borings, 2 parts fire clay, and 1 part fire sand. Mix with vinegar in the manner described.

### A Revolving Telephone Index on the Transmitter

EVERY user of a telephone has certain persons to call more or less frequently whose numbers may not be readily remembered. A list of these numbers may not be large and to look them up in the telephone book requires some time. A very handy

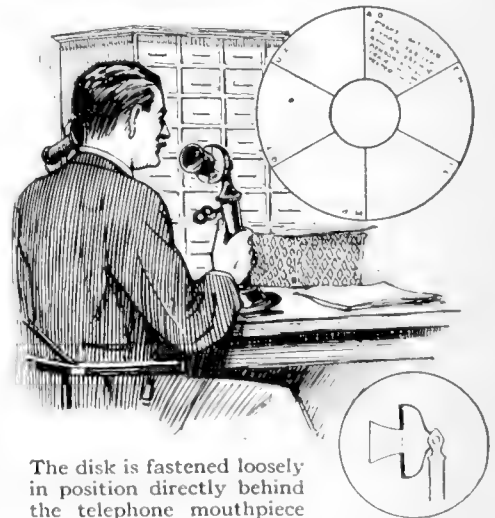

The disk is fastened loosely in position directly behind the telephone mouthpiece

and neat little index for a few numbers can be written on a cardboard disk and slipped on the neck of the telephone mouthpiece. It has six divisions and is fitted loosely so that it can be turned. The mouthpiece is unscrewed and taken off to place the disk in position.

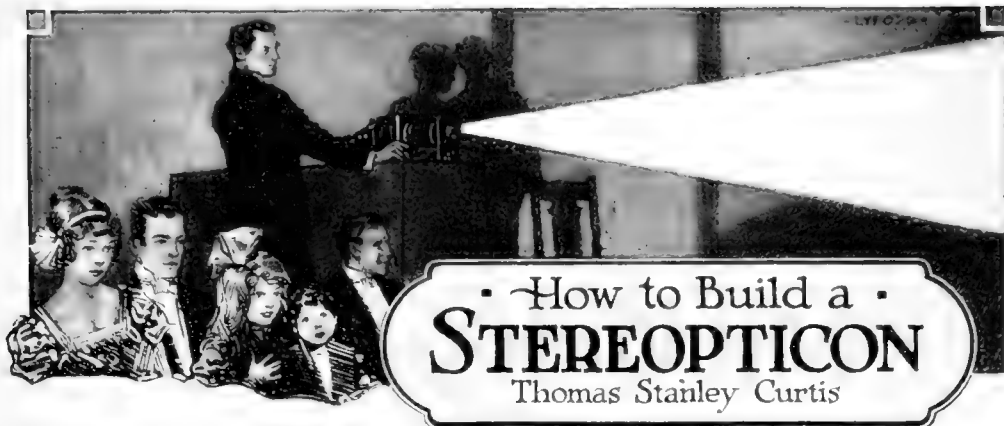

## • How to Build a • **STEREOPTICON** Thomas Stanley Curtis

**T**HE construction of a small stereopticon for use in the home or lecture room is an easy task for the workman who possesses the usual tools, such as a hacksaw, small drill-press, taps, dies, etc. The design presented herewith is one well adapted to amateur construction, and in the finished instrument the builder will have one which incorporates, in a simplified manner, everything which makes for comfort and efficiency in operation. At the same time, it will cost little to build if the objective and condenser are purchased second hand.

From the illustrations, the reader will note that the finished instrument is of the conventional form with one or two exceptions. The usual bellows is supplanted by telescoping cylinders of metal; the bellows is difficult to construct and, when made, it is no more effective than the device shown in the drawing. The conventional lamp-hood of sheet metal has been supplanted by an earthen hood made from a flower-pot; this construction permits the use of a simply-made arc-lamp without gears or worms and, furthermore, it prevents the heat of the arc from attacking the lamp parts. The heat is dissipated through an opening in the top, above the arc, and the condensing lens is protected by a disk of thin glass loosely clamped to the front of the flower-pot hood. Every detail of the instrument and dimensions is shown in the drawings; it is therefore

unnecessary to repeat dimensions in the text of this article. Before starting the work, the builder should purchase the condensing lens, the objective and a slide carrier of the conventional sort. The condenser will cost, mounted as shown in Fig. 1, about \$2. The objective, Fig. 2 *A*, will cost from \$3 to \$10, depending upon its quality, focal length, and condition, if second hand. The slide carrier of the sort shown in Fig. 3 costs about \$5.

The focus of the objective will have an important bearing upon the length of the cylinders, *C* and *D*, Fig. 2, and the dimensions given are for a lens of 10-in. focus. This is an excellent size, as it throws a picture approximately 6 ft. square at a distance of 20 ft. from the screen.

If the instrument is to be used in a smaller room, the objective should be of shorter focus. These objective lenses are usually supplied in a mounting, with a flange and a knurled adjusting knob, which actuates a rack and pinion arrangement. The following table shows the sizes of pictures projected by lenses of varying focuses at various distances. For example: With a lens having an equivalent focus of 7 in., a picture 6.5 ft. square would be projected if the machine were

15 ft. from the screen; 8.5 ft. square at 20 ft., etc.

The table is prepared as an aid to careful selection of a lens suitable to the room in which the stereopticon views are to be exhibited.

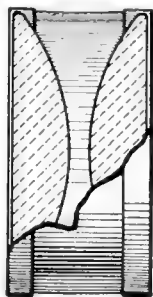

Fig. 1. The condenser

*Size of Picture on Screen with Lenses  
of Different Focuses When Using  
Standard Slide*

Focus of Lens	15 ft.	20 ft.	25 ft.	30 ft.
5 in.	9	12	15	18
7 in.	6.5	8.5	10.5	12.5
10 in.	....	5.8	7.3	8.8

The front board, which carries the objective, may be made first. The design is shown in Fig. 4, and the openings and general form should be described by measuring from the center line. The large openings may readily be cut with a fine jeweler's saw, or if the

shown in Fig. 6. These cylinders are made from thin sheet brass accurately cut and shaped by means of a tinner's roll. An accommodating tinner will usually be glad to perform such a small service without charge. The smaller cylinder should slide easily within the large one. It is then sweat-soldered to the lens-board, care being taken to see that it is exactly centered.

The slide-carrier holder, with the dimensions of its parts, is shown in Figs. 7, 8 and 9. The piece shown in Fig. 7 is soldered to the larger cylinder, *D*, Fig. 2 and the smaller ring of brass wire, Fig. 10, is sweated on at the junction.

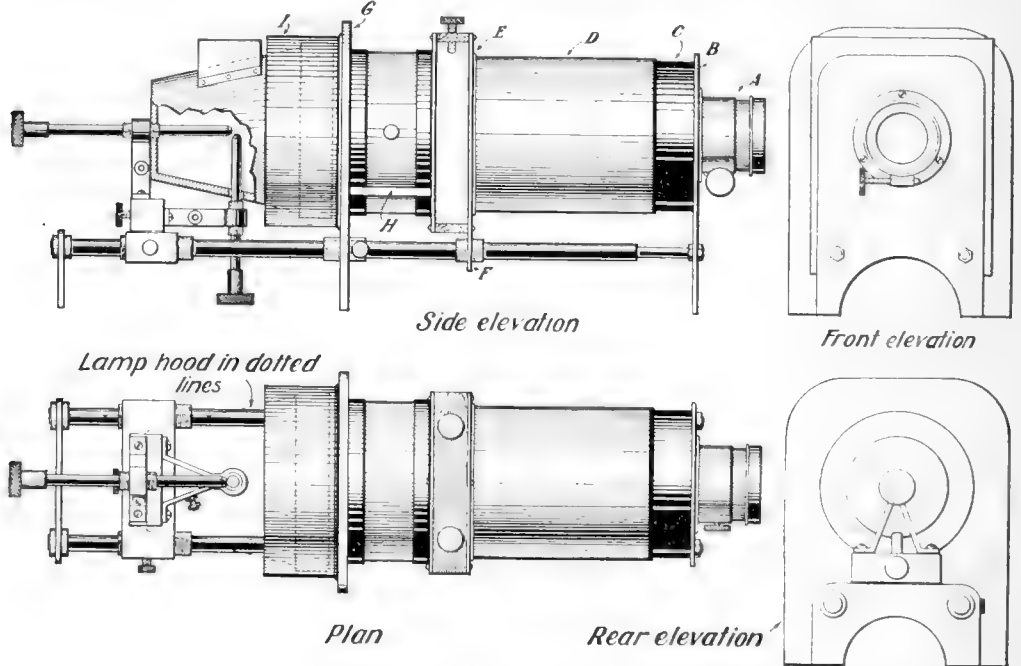

Fig. 2. The objective assembled. The lenses are usually supplied in a mounting, with a flange and knurled adjusting knob, which actuates a rack and pinion arrangement

builder has a power-drill, they may be roughly drilled and finished up to line with a file. The lens-opening will obviously have to conform to the diameter of the lens-barrel or its flange, which is made of sheet brass,  $\frac{1}{8}$  in. thick and secured to the board with machine screws.

The lens-board is held upright by two rods of brass, Fig. 5, which slide into brass tubes. Upon these tubes the remainder of the instrument is assembled. The dimensions of the telescoping cylinders which supplant the bellows are

When the cylinder is to be soldered on, the rods and tubes should be in place and the one cylinder telescoped within the other, to insure accurate centering. As the assembled drawing shows, Fig. 2, the upright *E* is gripped between the collars *F* which are forced over the tubes and soldered in place. The dimensions of the collars are all given in Fig. 11. The parts of the slide-carrier holder are assembled by means of screws; and clamping-screws in the top piece are arranged to engage the slide-carrier and secure it in the proper position.



The upright *G*, Fig. 2, serves to carry the light-shield *I*, which covers the lamp-hood. It also serves partially to support the condenser-mount, which is

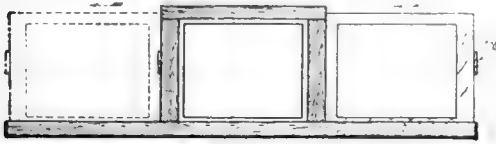

Fig. 3. A slide-carrier of the conventional sort, one of the parts to be purchased

loosely placed between the slide-carrier holder and the upright *G*, resting upon the studs *H*. The dimensions of the

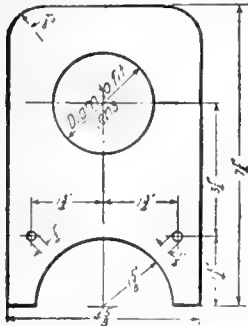

Fig. 4. Plan of front board which carries the objective

piece *G*, are given in Fig. 12. The light-shield *I*, detailed in Fig. 13, is to be hard-soldered to *G*. Owing to the heat encountered here, a far better construction is to bend feet all around the cylinder and rivet or screw it to the piece *G*. If soldering is determined

upon, however, the larger ring shown in Fig. 10 may be used to strengthen the joint and to improve the appearance.

The arc-lamp illustrated in detail in Fig. 14 presents many points of interest. It is adapted for use on comparatively small currents of from 5 to 8 amperes, and these values are practically at the topmost limit for home use. The lamp takes standard 1/4-in. carbons, which are fed by merely twisting and pushing the knobs fitted to their ends.

Each carbon of the lamp is held in a little bracket, which, in turn, is secured to a common base of hard fiber. The use of this material is permissible in the present instance, since

the heat conducted to it is comparatively slight. The fiber-block is drilled to take the upright rod shown in the drawing and is fitted with a clamping-screw. This adjustment will permit the lamp to be swung to either side, or raised or lowered. Theoretically, if the objective, condenser and arc are in line, no adjustment will be necessary, but, owing to the extreme difficulty of securing such an absolute alinement, a degree of adjustment is usually necessary. The holders, through which the carbons pass, are split in order that a slight friction may be exerted upon the rods.

The hood for the arc, as previously stated, consists of a small flower pot of the correct size, drilled for the holes

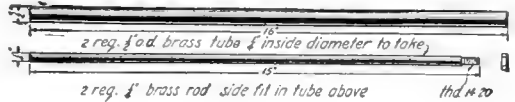

Fig. 5. Two brass rods which support the upright lens-board slide into brass tubes

indicated, and lined by smearing it with fire-clay on the inside. When the lining is dry and the hood fastened over the large opening in the top, the pot may be wired to the arc-lamp frame, or secured with small screws passing through the

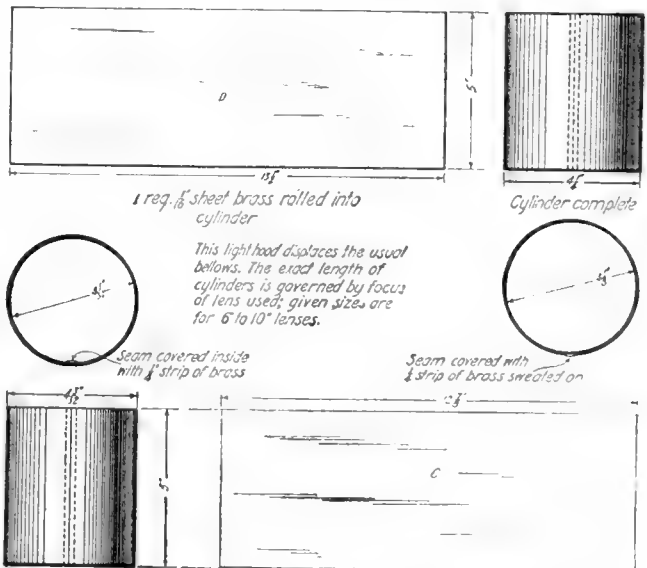

Fig. 6. The telescoping cylinders made of thin sheet brass accurately cut and shaped with a tinner's roll

bottom of the pot and into the brass bracket. The drawing shows how the disk of clear glass is clamped to the front of the flower pot. The method of

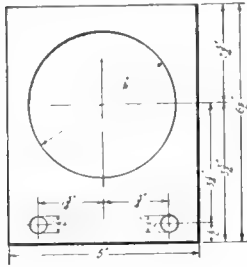

Fig. 7. A part of the slide-carrier holder

constructing the lamp-mounting, which slides over the brass tubes of the instrument frame, is clearly indicated in Fig. 14. The addition of the rear support, detailed in Fig. 15, completes the stereopticon.

For the sake of completeness, the details of a small rheostat are given in Fig. 16. While a lamp-bank, or any other form of resistance that will limit the flow of current to about 5 amperes, may be used, the wire resistance illustrated will be found inexpensive and compact. The base is a piece of slate about 8 in. square in which are mounted nine brass pillars. On either side and between these pillars are stretched

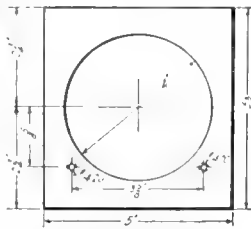

Fig. 8. Another part of slide-carrier holder

9 coils of No. 22 gage resistance wire, each coil containing 5 ft. of the wire. If wound in coils of 48 turns each on a rod  $\frac{3}{8}$  in. in diameter, the amount will be approximately correct. As the drawing shows, the coils are all placed in series.

In Fig. 17 is given the diagram of connections. The wires leading from the nearest lamp-socket connect with a switch and fuse. One wire goes directly to the upper carbon of the lamp, and the other wire goes to one terminal of the rheostat. From the second terminal of the rheostat, a wire

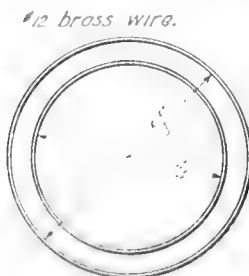

Fig. 10. Brass wire rings used to strengthen the numerous joints

connects with the lower carbon of the lamp. If the current is direct, the upper or horizontal carbon should be the positive. This can be insured by a simple test; turn on the current at the switch and bring the carbons together for an instant, separating them immediately for  $\frac{1}{8}$  in. If the current is direct, the arc will quickly settle down to an absolutely noiseless burning; if

alternating, the arc will emit a low hum. If direct current is used, turn the current off after the arc has burned a few moments and immediately observe the carbons; the positive will be the hotter one and if this should, by chance, be the lower, the wires at the lamp terminals should be transposed so as to establish the positive pole at the upper carbon. With a direct current arc, practically all of the light comes from the positive carbon, while with an alternating current, both carbons give off the same amount of light.

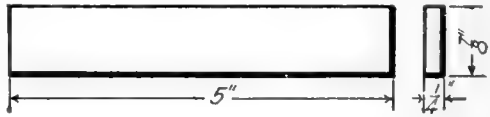

Fig. 9. Dimensions of the upper and lower frame parts of the slide-carrier holder

When the light has been tested, the stereopticon may be set up for use. Place the instrument upon a firm table and at right angles to the screen, which

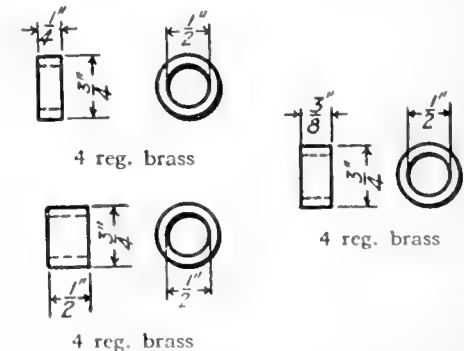

Fig. 11. Dimensions of the collars which are forced over the tubes and soldered in place gripping the lens-board

may be a sheet or a bare white wall. Start the light at the arc and darken the room. Place a slide in the carrier and bring the lens into focus by sliding the

lens-board in or out. Remove the slide and adjust the arc-lamp to remove the bluish spots that will most likely be seen in the field of light. By moving the lamp up or down, to the right or left, or

should be kept scrupulously clean, since the slightest trace of dust will diminish the brilliancy of the illumination to an astonishing degree.

Lantern-slide plates may be obtained from any dealer in photographic materials. The standard size is  $3\frac{1}{4}$  in. by 4 in. in the United States, and all slide-carriers made for use in this country take that size. The lantern slide emulsion or coating is so sensitive that the slides must be handled under ruby or deep orange light only, in order to avoid fogging. With this one exception, they may be handled precisely as one would use the popular developing-out papers.

To make the slide, the plate is placed in a printing-frame, with its emulsion (dull) surface next to that of the film or plate from which the print is to be made. The frame is then held at a distance of about 6 ft. from a 25-watt tungsten lamp, and the latter turned on for two seconds. This exposure is correct for the average negative and is cited merely

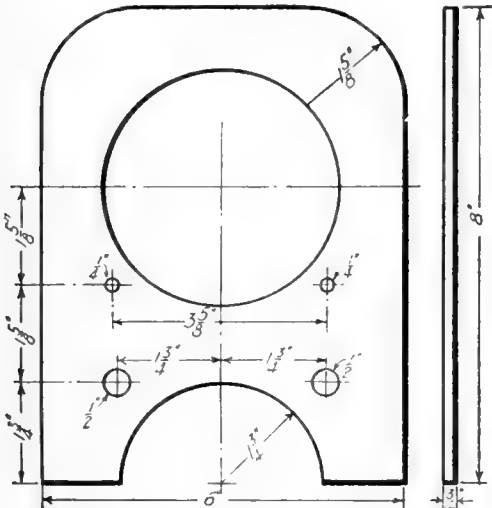

Fig. 12. Dimensions of the upright which serves to carry the light-shield

back and forth upon the tubes, the field will gradually be made perfectly clear. When the light is uniformly white, the slide may be replaced and a sharp focus obtained by turning the milled, adjusting knob on the lens-barrel. All lenses

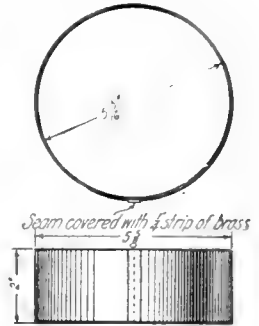

Fig. 13. The light shield which is soldered to the upright

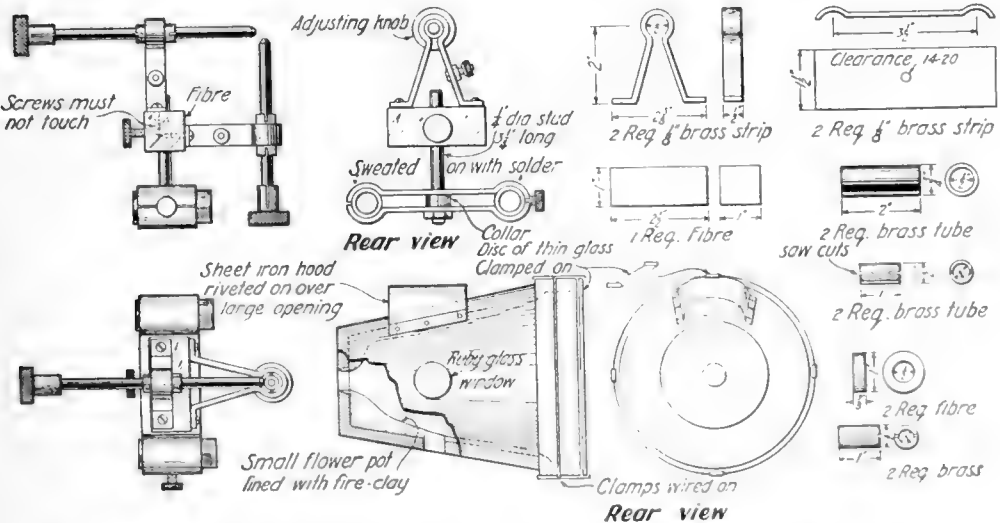

Fig. 14. Details of the arc-lamp which is adapted for use on comparatively small currents. The carbons are fed by merely twisting and pushing the knobs fitted to their ends

as an example; even oil, gas or a match, held a foot from the frame, may be used instead. The exposure would then have to be determined by experiment, of course.

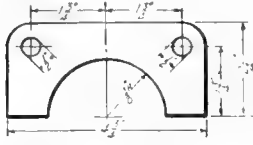
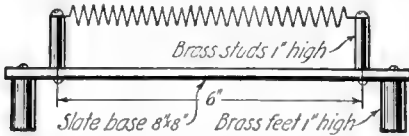

Fig. 15. Detail of the rear support

When the exposure has been made, the plate is taken from the frame and placed in a tray containing the developer. The writer favors the popular M.Q., sold in tubes and merely dissolved in water. In about thirty seconds the details of the image will come up under the action of the developer, and in possibly a minute and a half, the development will be complete. This is determined when the entire image is plainly visible, though hazy, on the reverse side of the plate. Another test is to look for the details in the highlights; when they are visible, the plate is developed. The tray should be rocked continually throughout development.

The next step is to rinse the plate in clear water and immerse it quickly in a bath of hypo, which may be purchased in



3 Coils each containing 5 ft. of No. 22 resistance wire. Wind 48 turns on  $\frac{3}{8}$ -in. rod

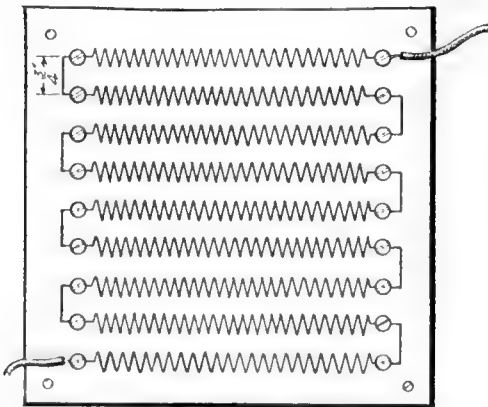
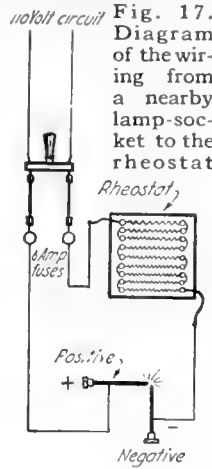

Fig. 16. Details of a small rheostat. In the slate base nine brass pillars are mounted

small packages ready to be dissolved in water. When no more of the milky whiteness can be detected on the plate when



viewed from the back, it should be left in the hypo ten minutes longer, and then taken out and washed under running water for a half hour. All of these operations must, of course, be performed under the orangelight.

The trick which is perhaps the most important of all in the making of a slide has been left until the last, where it will be noted and remembered. When the slide plate is placed in the printing frame ready for the exposure, a piece of black paper should be placed over the back of it before the cover of the frame is clamped in place. This is to prevent a disagreeable foggy flatness from spreading all over the slide-plate, which will happen if the reflected light from the white backing of the printing frame strikes through the glass. The author has made hundreds of slides without the slightest difficulty since he discovered this little stunt. Prior to that time he had found it impossible to secure a brilliant slide from any but the snappiest of negatives.

A concluding word of caution is to avoid touching the emulsion side of the slide plate at any stage of the operations. The emulsion, when wet, is soft and easily injured and, when dry, the oil from the fingers will leave a mark. While the slide is drying, it should be protected from dust and dirt, preferably by placing it in a clean, dry place. A mat or mask and a cover-glass bound on the slide with passe partout binding complete the work.

### A Substitute Blow Torch for Soldering Joints

**A**N easily improvised blow torch for soldering joints in wires is made as follows: Take a  $\frac{1}{2}$ -in. tube, and fill it with cotton waste or with old cloth saturated with gasoline. Cut a notch in a piece of  $\frac{1}{4}$ -in. loom, insert it into one end of the tube, and light the waste. Blowing through the loom makes a hot flame.

To Make a Storm Vestibule on a Veranda

As may be seen from Fig. 1, the entrance to which the storm vestibule was added extends out into the veranda about 2 ft. beyond the general front wall line of the house.

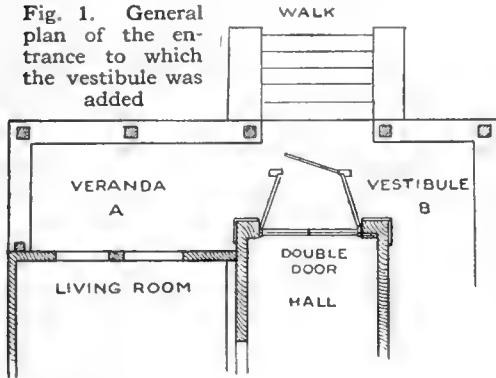

veranda-roof is supported by five columns, about 6 ft. apart. Two of these flank the stairs from the walk to the porch. The hall is 6 ft. wide, and the big double door with glass panels, is fully as wide, less the trim. The makeup of the door-casing is such as to provide a good  $\frac{7}{8}$ -in. stop all around outside. A sketch was made like Fig. 1. This shows that the narrow portion of the porch, which is only about 4 ft. from the door-casing to the posts, would be filled up by a rectangular structure, so that it would be inconvenient to reach either portion A or B of the veranda from the steps when the vestibule was in place. Therefore the shape was altered as shown, leaving sufficient room for a person to pass comfortably to either section of the veranda.

The plan of the vestibule is shown in Fig. 2. Its position on the porch floor is defined by the strips shown outside the side panels. These are square, about  $1\frac{1}{2}$  in. each way. They are screwed to the porch floor, and also to the side panels. The side panels and door frame are assembled as shown in detail of the joint at C. This joint is secured by screws passing through the door frame into the wedge-shaped piece, which is integral with the side panels. If the work is properly fitted, three screws on each side will be sufficient.

In the cross-section shown in Fig. 3, the construction of the top is indicated. This is made of tongue and groove fencing, the same as the side panels, and battened. The rear edge is made to slip in tight under the frame of the house door, and the battens are so placed that the side panels bear against them. It is not necessary to secure this piece except with two small hooks and eyes on each side, by which it is fastened to the side panels, so as to prevent entrance of cold air if it should warp. Sufficient projection of the top panel is provided to allow a crown-mold to be placed under it similar to that shown on the door frame in Fig. 3. This makes a cornice all around the vestibule, and is an attractive finish. These two pieces are attached to the side panels, and are mitered against the mold across the front.

The entire scheme consists of five pieces: two side panels, the top, the door frame, and the door. The door was purchased, with plate-glass upper panel, from a dealer in house-wrecking materials for a moderate sum. The rest of the material is plain lumber-yard stuff. The work of building and fitting such a vestibule must be carefully planned, and honestly executed. Skimped work will show and prove troublesome. But when once built it can be

Fig. 2. Plan of vestibule

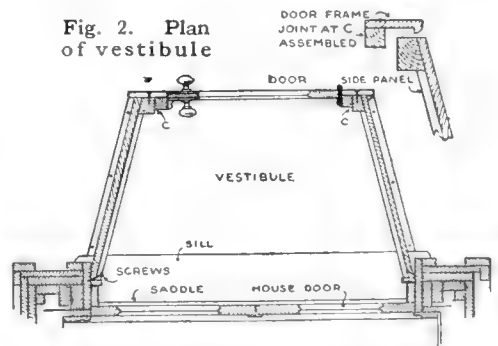

erected or removed in half an hour, with no tools but a screwdriver.

The door should be hung on loose pin-butts, of good weight and quality. They should be brass, steel bushed, with steel pins, brass tipped. The lock hardware and all the removable screws should be brass. This is because steel

screws would sooner or later rust in, and it would be difficult to remove them. All fitting and adjusting should be done when first building the structure, and it will then go together without trouble when erected afterward. The side lights shown are not necessary when the storm door has a glass panel.

The door for this particular model was made to open outward, as the vestibule was too shallow to permit of its opening inward. When sufficient depth is available, it is preferable to change the details so as to permit the door to swing inward. In this case, cheaper butts, plain steel for instance, may be used, as there is no weather exposure, and the lock may be a common rim or mortise affair for the same reason. All screws, however, should be brass in any case. The door may be weather-stripped when it opens out, but if opening inward it will usually be necessary to use a threshold, as the average porch pitches away from the house, and this must be provided for.

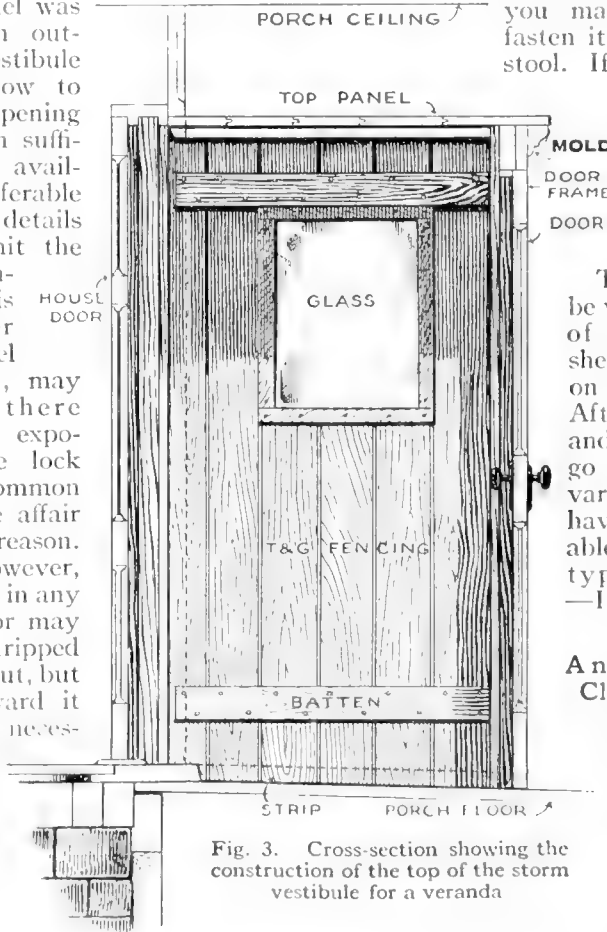

Fig. 3. Cross-section showing the construction of the top of the storm vestibule for a veranda

### An Easy Method for Drilling Holes in Glass

**I**N drilling a hole in glass, first take any hard metal, press and turn it on the face of the glass at the point where the hole is desired until the glazed surface is broken. This will give a center or starting point for the drill. Then with a hand-brace and drill bore slowly, placing a little turpentine on the drill.

### Utilizing a Piano Stool as a Typewriter Stand

**A** PERSON who uses a typewriter at home will find that a piano stool will make a very good stand for his machine. An ordinary table is too high.

A good way to make the stool even more serviceable as a typewriter stand is to get a board, the size you may deem fit, and fasten it to the top of the stool. If the stool will not

turn up as high as you would like to have it you can build it up under the board you are using as a top.

The board used can be wider than the top of the stool, and shelves can be made on the extension. After the top is on and the shelves made, go over them with varnish and you will have a very serviceable and inexpensive typewriter stand. —IRAR. ALEXANDER.

### An Emergency Clothes Hanger for the Traveler

**W**HEN traveling or visiting, one frequently is so situated that a clothes hanger is not available. A good substitute

may be made in a quick and simple way, and the materials are always at hand. Roll up a newspaper loosely and tie in the middle with a piece of string, leaving a loop by which to hang it. This may be suspended from a gas bracket or other handy hook, and will take care of light-weight articles.

In washing an automobile use only soft water as it is not so hard on the finish, nor does it corrode uncovered metal.

**A Scheme for Soldering Metals  
Difficult to Join**

**M**ANY times when soldering together different metals which do not join easily it is better to put acid on each piece and fasten the solder to it separately. The pieces can then be soldered together without using more acid.

This method is especially advantageous for fastening two pieces together, where if acid were used, it might run into places difficult to reach with a cleaning cloth so that it could not be wiped away and would corrode the metal.

**A Heat Deflector for a Hot Air Register**

**A**SHEET metal canopy placed over the ordinary hot air register will direct the heat toward the bottom of the

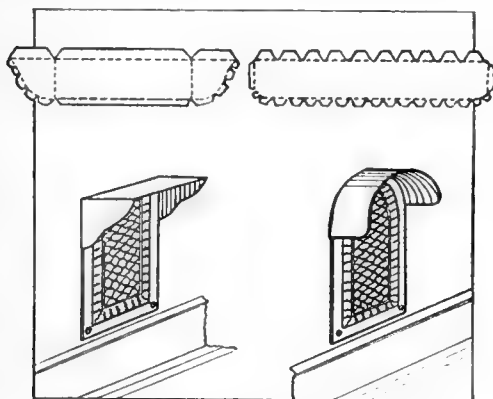

The metal canopy deflects the hot air outward and down toward the floor

room where it is most needed. Strips of fairly heavy metal about 7 in. wide are cut as shown in the illustration. The back is turned in at an angle of 90 deg. and fits in behind the register. After the canopy has been bent into shape the screws in the register are loosened and the back slipped behind it. Then the screws are replaced.—E. C. STILWELL.

**How to Straighten the Crooked  
Straws of a Broom**

**T**AKE a pail of boiling hot water and completely immerse the straw end of the broom for ten minutes. After the straws have become completely soaked,

withdraw the broom and suspend it by the handle. When the straws are dry they will be found to be perfectly straight.—E. HUNTSMAN.

**An Automatic Cleaner  
for Bicycle Hubs**

**H**UBS of bicycles readily collect dirt, and because of the spokes they are very hard to clean. With the little

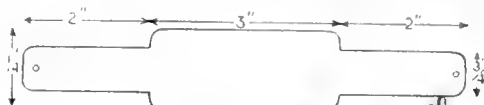

The weight of the chain link keeps the leather from turning with the wheel

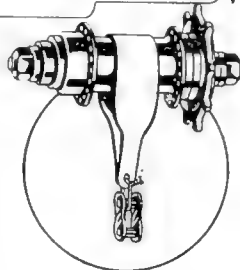

device illustrated the cleaning is done automatically and the surface kept polished. The device consists of a piece of leather shaped as shown, then hung over the hub, the ends being fastened with a link of chain. This link besides holding the leather on the hub is also convenient for repairing a broken chain in an emergency.—M. J. SILVERSTEIN.

**An Improved Force-Filter Which  
Is Easily Cleaned**

**M**OST force-filters, used for rapid quantitative work, catch the filtrate in flasks, which are often hard to clean after a filtration, especially if some of the precipitate passes through the filter-paper.

This disadvantage can be overcome by catching the filtrate in a beaker under a bell-glass, with a top for a two-hole rubber stopper. A funnel is inserted with a glass tube which is connected by means of a rubber tube to an aspirating-pump. If the suction is strong, a platinum cone should be placed in the funnel to prevent the paper from tearing. The glass or metal plate, upon which the bell-glass rests, should have a slight coating of some sticky, pasty material, such as that used on the disk of an exhaust pump, which will render the contact perfectly air-tight.—EDWARD MUTCH.



### Plane Blade Clamp and Emery Wheel Guide

WHEN sharpening a plane blade or a chisel 1 in. or wider, it is difficult to obtain a true edge even when both hands are free; and since the advent of the small hand-power wheels it is still more difficult where only one hand is available for guiding the tool. The guide shown here is intended to counteract the difficulty.

The clamp which holds the plane blade, Fig. 1, is made of iron, with the exception of a small oak sliding block. A strip of iron 8 in. long by  $1\frac{1}{2}$  in. wide and  $\frac{1}{8}$  in. thick can be procured at a hardware store or blacksmith shop. Heat it red hot and bend it over an anvil or vise to bring it to the necessary form, as shown in Fig. 1. When it is sufficiently cool touch up the rough surface with a file or emery wheel. Procure some  $\frac{1}{4}$ -in. round iron rods, cut them the required lengths, according to the design, and thread with a machine-screw die,  $\frac{1}{4}$  in. by 20 or 24 threads. Make the holes for the adjusting screws with a  $\frac{3}{16}$ -in. twist drill and tap them with  $\frac{1}{4}$ -in. by 20 or 24 tap. The handles on the screws are made of short pieces of nails set snugly in a  $\frac{1}{8}$ -in. hole.

The sliding block of oak on the horizontal adjusting screw is about 1 in. by  $1\frac{1}{2}$  in., and perhaps  $\frac{1}{2}$  in. thick, allowing sufficient depth for the long screw to be seated in it. Make a small groove on the end of the screw nearest the block and put in a brad to keep the screw from drawing

away from the block. Before attaching the block, rabbet the lower corner which will overlap the plane or chisel blade, or inlay a small strip of fairly stiff brass in the top of the oak block, setting it with glue, so as to form a wearing surface for the vertical screw, as when sharpening a narrow blade the oak block may come under the screw. In order to have the emery wheel and guide always in line and set up square it is well to have the wheel clamped to a board which can be used as a permanent base; then the device can be fastened to the workbench as a unit or hung out of the way when not in use.

The runway itself is made of wood, as the wear is very slight. It should be at least twice the length of the sliding clamp. Have it about  $1\frac{1}{2}$  in. wide by  $\frac{3}{4}$  in. thick. With a rabbeting plane take off the top to the depth of  $\frac{1}{8}$  in., leaving a small raised edge about  $\frac{1}{8}$  in. by  $\frac{1}{8}$  in., which is to guide the clamp, as shown in the detail in Fig. 3.

Another way would be to screw on a thin metal strip, raising one edge  $\frac{1}{8}$  in. above the top of the runway. Fasten a small angle iron at each end of the runway. Secure them to the sliding support on the right, and to a permanent support on the other end. Small bolts with thumb nuts will render the runway adjustable, so that a blade can be ground at any desired angle. The runway should be set up at a perfect right angle to the center of the wheel.

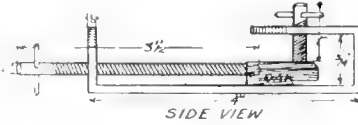

Fig. 1. The clamp which holds the plane blade is made of iron with an oak sliding block

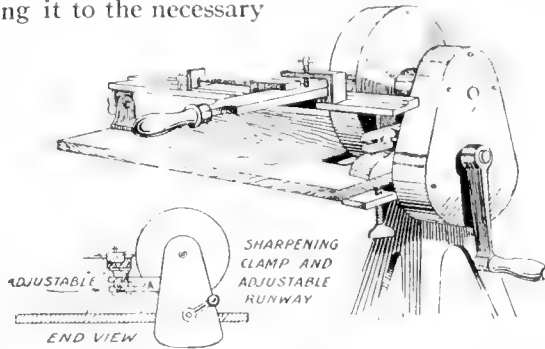

Fig. 2. The wheel is clamped to a board which may be used as a permanent base for stability

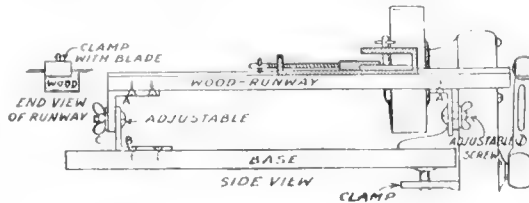
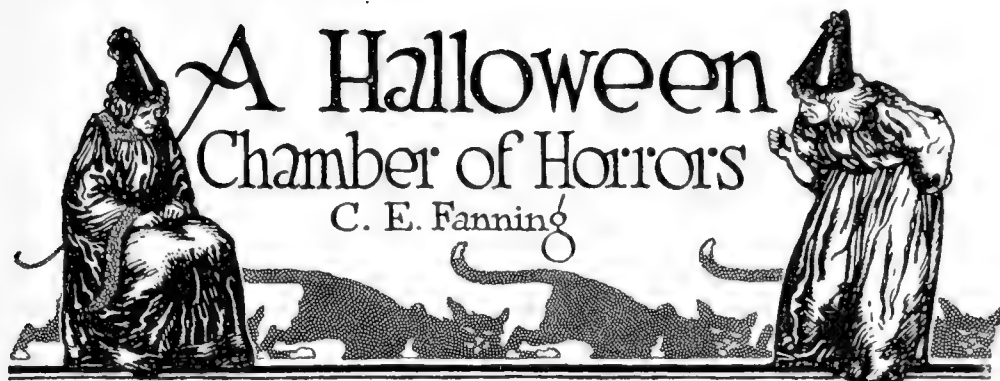

Fig. 3. The runway may be made of wood and should be twice the length of the sliding clamp



**H**ALLOWEEN entertainments where young people of both sexes participate are usually characterized by merrymaking in which witches of a more or less friendly type are the principal feature; but where none but brave scouts of the *genus homo* are present, as at a club or a boys' school, the horrors may be as real as they can be made. The "Chamber of Horrors" described here was fitted up by boy students last October 31, and the thrills and shivers which the participants in the fun received are not yet forgotten. The materials used were borrowed from the school laboratory or from the students' homes. The experiences began at the very entrance doorway.

Beside the arch outside the entrance, which was draped with black crepe and surmounted by a sign reading, "The Cave of Death; All Hope Abandon, Ye Who Enter Here," stood a witch in skeleton mask and long black robes, who barred the way with a long dry bone, questioned each applicant as to his strength of nerve, and in serious tones made each assert that he entered the cave at his own risk and peril. Two raps from within the closed door signified that the victim had permission to enter. In the arch under which the victim passed hung a human skull and cross-bones, suspended by fine wires. Those who were curious to touch or handle them, received a moderately severe shock.

As the victim placed his hand on the knob to open the door, he received another shock and was commanded in hoarse whispers to close the door behind him. The room which he now entered

was absolutely dark, except for phosphorescent hands here and there, and a phosphorescent skull near him. Before he had time to see them distinctly, something cold and flabby struck him in the face. A pair of the gleaming hands picked up the phosphorescent skull, and a voice whispered, "Take this baby's skull in your hands. Press it to your lips. There are maggots crawling on it—a-a-a-h."

After actually experiencing the revolting sensation of maggots crawling over his lips the victim was allowed to proceed. He was struck again in the face by something cold and flabby. A blinding light flashed in his eyes with a report like that of a pistol. "Look!" said a hoarse voice. Before him he saw an irregular-shaped greenish light, shining down upon some white object stretched upon a table. "A corpse," said the voice. One of the phosphorescent hands took his own and placed it on that of the corpse, which was cold and clammy, and also on the foot, which gave the same chilly thrill. From the dead man's side, a jack-in-the-box jumped in the victim's face. The flickering light died and the whispered voice commanded; "Proceed!" He passed between two phosphorescent snakes, crawling on tables. A door-knob glowed nearby with a phosphorescent light. From just above the knob, with a loud and continuous crackle, a 6-in. spark commenced leaping to a point by the side of the door. As soon as he started toward the door, this spark, which would really have been dangerous to receive, ceased, and when he went out of the door, he received the same comparatively mild shock he had

felt when he opened the first door.

Nearly all these effects, and a number of others, were produced by comparatively simple means. It is important to have someone in charge of the chamber who can talk—or whisper hoarsely and convincingly, in order to make a pound of raw beefsteak and a chunk of ice which

The flabby objects which strike the victim's face are merely rubber football bladders (hot-water bags would do as well) kept moist, and suspended from the ceiling at the average height of the face. They are merely drawn back and allowed to swing into the face of the victims (Fig. 3). It was necessary to use the scheme diagrammed because every movement of the phosphorescent hands was visible.

The baby's skull was a papier-maché candle-shade picked up at a ten-cent store. The illusion of the crawling on the lips was produced as follows: The skull was coated with tinfoil which was connected with insulated wires to one of the poles on a medical coil, the other pole of which was attached to a metal floor-plate located where the victim would stand. The coil was tuned down so low that the shock could not be felt in any other part of the body except the sensitive lips, and gave them exactly the impression of numberless small crawling objects. The bright light which flashed in the eyes was merely a pocket flashlight; the sound which accompanied

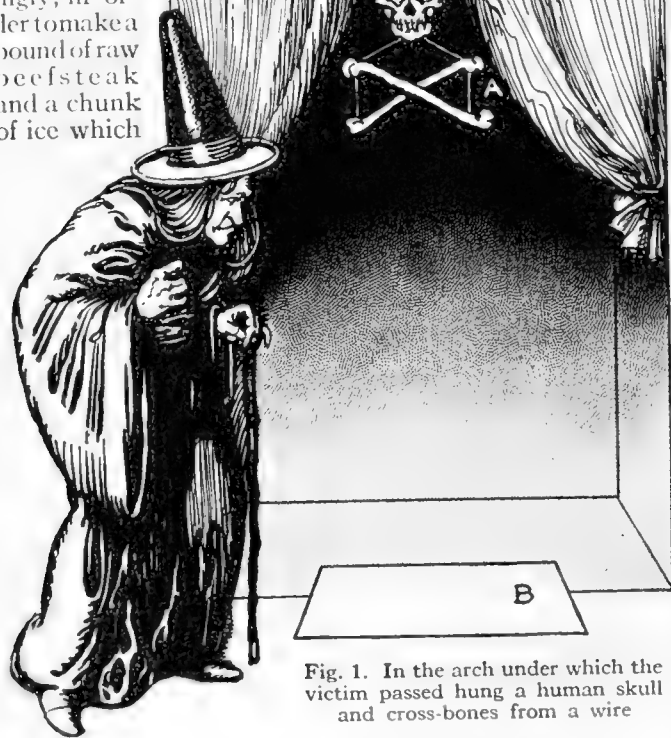

Fig. 1. In the arch under which the victim passed hung a human skull and cross-bones from a wire

are used occasionally sufficiently terrible. But, of course, the more mechanical and electrical effects there are, the better.

All the electric shocks came from a small but active induction coil operated by three or four dry cells. One pole of the coil was connected with fine wires that suspended the skull outside the entrance (Fig. 1 and Fig. 2, A), with the door-knob at the entrance (Fig. 2, B), and with the one at the exit C. The other pole was connected with a number of steel door-mats properly placed as D, E, and F.

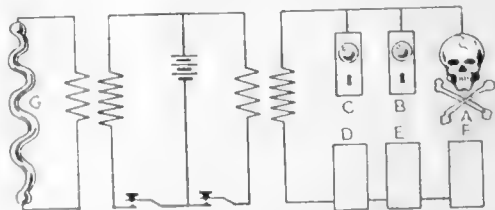

Fig. 2. Wiring diagram showing connections to the skull, door-knobs, plates, etc.

it was made by a sharp blow with a hammer on a piece of sheet-iron suspended from the ceiling.

The corpse was a pasteboard torso in the possession of the biological laboratory, but stuffed garments would have been just as serviceable. The weird light above it was produced by a Crookes' tube from the physics laboratory, operated on another small induction coil (Fig. 2, G). The dead man's hand and foot were of course a glove and stocking filled with wet sand. The snakes were real, but artificial ones would have served as well. The 6-in. spark above the door-knob, which was probably the only effect not available in the average high school laboratory, was produced by a large induction-coil operating on a current of about 50 volts, taken through a rectifier and a rheostat from an ordinary electric lighting circuit.

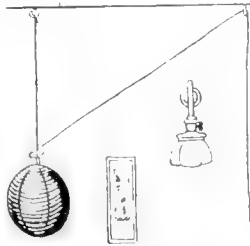

Fig. 3. Suspended air-bag of a football

Although there are a number of phosphorescent paints on the market, the paste used in this instance was made from the heads of three or four boxes of matches and a little water. Anything which is a sudden shock or surprise is valuable. Snakes, rats, bats, and anything suggestive of death or decay

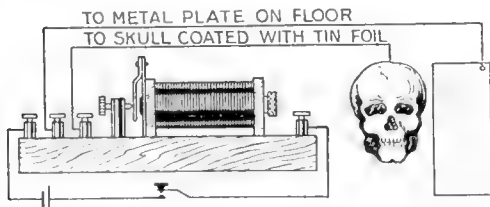

Fig. 4. Connection of the wires from the medical coil to the footplate and the skull

will arouse terror in most people; but one boy went through the entire chamber without having any impression made upon him. Just as he was going out the door, however, a terrified yell proclaimed that the big rattler had gotten loose in the darkened room. There was really no rattler in the room, but the boy went out thoroughly frightened at last.

### An Alarm-Clock Dinner Bell for Old Dobbin

FROM the standpoint of the man about the house, the dollar alarm-clock has filled more long-felt wants than any other modern invention. In these columns alone articles have already been published telling how to open the furnace-door with an alarm-clock, how to control electrical toys with alarm-clocks, and a generous number of interesting and ingenious plans for awakening the entire family by alarm-clock systems. The latest alarm-clock idea will interest the man who either forgets or is too busy attending to other things, to feed his horse.

An alarm-clock is securely fastened to the top of a grain-bin and set to release a trap-door at a certain prescribed time. There is a small catch which allows the door to drop. This is operated by a cord running up to the clock and around the alarm-winding key. The alarm is set for the feeding time, and when the key revolves, the string is pulled, the door drops and the grain pours into the trough.

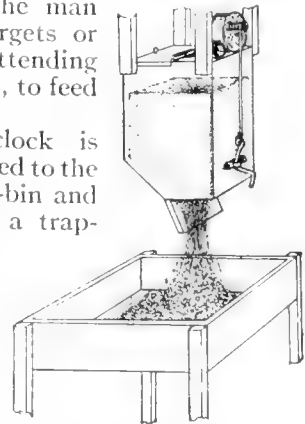

Tripping the trap-door with an alarm-clock

### An Experiment with the Static Electricity from Belts

THE following is a little experiment with static electricity. Take an ordinary electric light bulb, grasp it near the tip, taking care not to get the fingers near the screw-socket on the other end, and hold the bulb near a slipping belt that is generating static electricity, so that the brass almost touches the belt. Sparks will be seen to pass to the bulb, which is then acting as a Leyden jar, and will hold a considerable charge, depending on the size of the bulb. The amount of the charge can very well be apprehended by touching the brass end to a water pipe.

### Brackets for Double Sheets of Wrapping Paper

MANY storekeepers still use double flat sheets of wrapping paper, in bundles which are usually piled in some

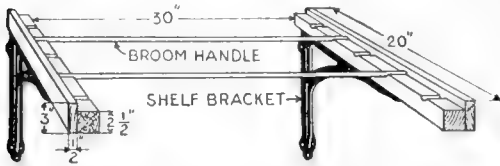

Two brackets fastened to the wall with holders for large sheets of wrapping paper

out-of-the-way place difficult to reach. A contrivance for holding this paper may be made as follows:

Fasten two iron shelf-brackets to the wall about 30 in. apart and 4 ft. from the floor. On top of each bracket screw a strip of wood  $2\frac{1}{2}$  in. square by 20 in. long; then nail a small strip 3 in. wide and  $\frac{1}{2}$  in. thick to the outer edge of each one of the large strips so that the small strips are  $\frac{1}{2}$  in. higher. Cut grooves with a half-round chisel or bore holes with an auger in the top of each large strip as far as the small strip. Iron rods the length of the distance between the strips can be inserted in the grooves with the wrapping paper hanging over them where they can be obtained quickly. The small strips nailed on the sides of the large strips prevent the rods from slipping out.—E. M. RITT.

### Keeping Roasted Peanuts Hot on a Steam Radiator

IN THE front end of a confectionery store there was placed a large steam radiator made in a perfect circle of vertical pipes—one of the old-fashioned kind. The leaseholder of the room

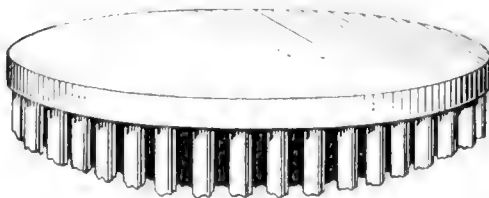

The heat from the steam radiator is sufficient to keep the roasted peanuts hot

utilized the large volume of heat in a very unusual manner. Having a large trade in roasted peanuts and not caring

to have the roaster in the front of the store the peanuts were kept hot in the bags on the radiator.

To give this arrangement a pleasing appearance a large disk of galvanized sheet iron was cut and a tinner seamed it to an apron so as to make a huge "can cover" to fit snugly over the radiator top. The bags of peanuts were kept on this metal cover and served hot to the customers.

### An Automatic Grain-Valve to Prevent Waste

A MILLER in a small flour mill had occasional trouble with a bin that was continually running over. By applying the device described the difficulty was overcome by stopping the flow of the grain automatically.

A paddle is inserted in the bin and a

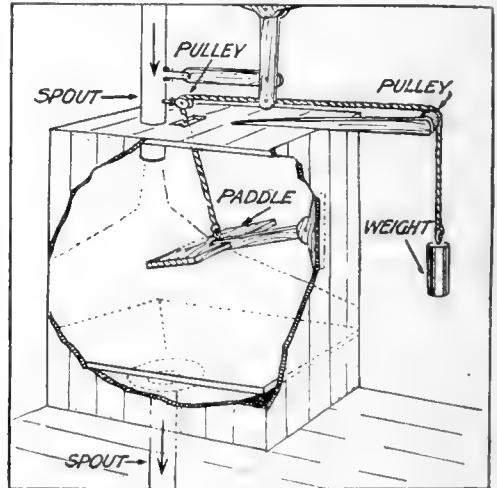

When the level of the grain is below the paddle the weight opens the valve

rope attached to it which is run over pulleys and fastened to a lever that opens or closes a slide valve in the grain spout.

When the grain is running out of the spout it is naturally settling in the bin, and if the bin gets so full that it covers the paddle, the paddle is slowly pulled down with the sinking grain. After the grain has been shut off and the level is below the paddle, the weight opens the valve. A paddle with two square feet of surface will pull hard enough to break a small rope, so very little surface is required.—VICTOR PAGÉ.

**Making Storm-Sashes from Old Shutter-Frames**

THE owner of an old-fashioned house which presented several examples of architecture of a past age found a way to convert the shutters into a modern convenience.

He removed the slats, leaving the frame of each pair intact. These frames he fastened together at the meeting rails with long wire finishing nails to each piece. To further stiffen the frame, so as to keep it in line, 1 in. of the lower rail was sawed off and the space filled with two 1/2-in. strips nailed on at the top and bottom. All the blind hardware was removed. The scars resulting therefrom were smoothed over with a scraper and sand paper, and touched up with a priming coat of paint, after which all screw holes were puttied and blocks were fitted into the notches made to receive the end of the lifting rod when the shutter slats were closed.

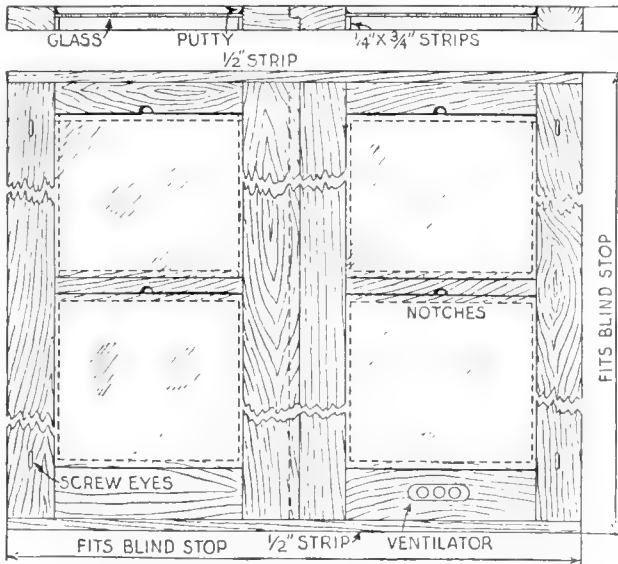

Old-fashioned shutter-frames used for storm-windows by substituting single strength glass for the shutter slats

It will be necessary to cut these lights in almost every case, as the openings in the shutters are usually not made to glass sizes. For this purpose the ordinary steel six-wheel glass-cutter will be found satisfactory.

To cut the glass lay it on a flat-top table, large enough to support it with a margin all around. Pad the table surface with 3 or 4 thicknesses of newspaper, and on top of this put a sheet of stout wrapping paper, on which draw two strong pencil lines at exactly right angles. The lines form the gage. One corner of

the glass is placed in the angle and two sides are made to agree exactly with these two lines. The opening should be measured in each case, and the measurement laid off on the paper so as to be seen through the glass. This should be done for each panel, as they may vary slightly in size. Cut

about 1/16 to 1/8 in. scant of each measurement to prevent the glass from binding in the frames.

Use a strip of wood not less than 1/2 in. thick for a straight edge and have it long enough to gage the longest dimension without shifting. Measure the thickness of the cutter-block carrying the wheels. Put the plain side against the straight edge and allow for the thickness of the cutter-block. Dip the cutter-wheel into turpentine and make a quick stroke from end to end of the glass. Never run over the cut a second time. A piece of cardboard should be provided having a thickness equal to that of the glass. It should be placed at the end of the cut to prevent break-

This completed the frame except that there was no rebate to support the glass. Strips 3/4 in. wide and 1/4 in. thick were procured and cut to the proper lengths. These were fastened with brads around the inside of each opening for the glass to rest on when put in place. They were given a priming coat of paint so that the putty would adhere. The glass was ordinary single strength, known as "B" grade. This glass is not perfect, but it admits as much light as any other grade and it is inexpensive. For the ordinary window, four lights about 12 by 28 to 14 by 30 in. are required. The latter size has 17 lights to the box; the smaller size, 20 lights.

age there. Cut both edges in this manner; take the glass up in the hands with one thumb on each side of the cut and a folded first finger of each closed hand underneath, then bend sharply upward. The cut will part its entire length, clear and clean. Out of 80 lights cut in this manner only two were broken. Occasionally a pane will appear to be cross-grained and will not break clean. In this case "nibble" the edge down with a pair of flat nose pliers. Never use the slots on the cutter unless you are expert in the use of them. Practice some cuts on waste glass before starting to cut the stock.

After the glass is cut, it is set, fastened with glazier's points and putted in the usual manner. To make it fit the frame snugly so that it will be air-tight, putty should be placed in the rebate first before setting the pane, then each pane is fastened by laying a glazier's point on the surface and driving it in with the side of a chisel, swinging the bevel part back and forth in contact with the glass. Do not set the panes too tight or they may break. Some allowance should be made for expansion. If the putty is too stiff soften it by adding some linseed oil and kneading it in the hands. If too soft and sticky add a little powdered whiting and work it in the hands to the proper consistency. When the joint is finished run the finger firmly but lightly around on the putty to smooth it and make it pack properly. The touch is quickly learned after a few trials. When the putty has set, say 48 hours, the glass should be cleaned with alcohol and water and given the final coat of paint.

When this is dry the hanging operation takes place. For all second-story windows, hangers should be used. To locate the hangers use a dummy frame, to which hangers have been fastened with screws in the proper position. With this the hooks in which the hangers engage are easily placed on the window-frame head without handling the heavy sash in each case. The lower windows may also have hangers if desired.

Improvised hangers may be made of brass screweyes turned into the inside of each frame about 10 in. from the top and bottom in such a way that when the

sash is in place a 4-penny nail, driven through the screweye and into the side of the window frame, will make a tight fit. This, of course, makes no provision for ventilation; but a ventilator may be made in the bottom of each sash by boring three 1-in. holes side by side. A shutter of galvanized iron pivoted at one end, covers these holes when required, or may be swung aside on the pivot to open them. When open, with the upper sash lowered, the desired ventilation is obtained without draft. A screweye, located opposite the pivot, could be turned to fasten or release the metal shutter.

The sashes on the upper windows of the house in question were provided with hangers for ease in handling, and they also had screweyes for fastening the sash permanently. A button-hook was used to pull the sash up tight, by hooking it into the screweye while the nail was being driven. When all were in place the sashes were calked to the frames to make them air-tight. Strips of cloth about 1 in. wide were used. These were pushed in with a thin-bladed putty knife until no draft could be felt when the hand was held to the calked crack.

If for any reason it is not desired to use the blind frames as described, the frames can be made from new material, or that which may be gathered around the scrap pile. An old hotbed sash will furnish the material for a very satisfactory storm-sash frame. It is not necessary to use mortised joints. The corner joints may be made with lapped ends and the mullions nailed in place. Of course, the built-up frame will admit more light than the one made from a blind frame, but otherwise it has no advantage.—H. S. TALLMAN.

#### Getting Maximum Service from a Typewriter Ribbon

**T**YPEWRITER ribbons that have been worn out may be used again by making the ribbon double and winding it on the spool. It will give considerably more service and will write with much of its original clearness. On a typewriter that has average usage this hint will save several dollars in the annual ribbon bill.—J. ARTHUR REID.



Lubricating Automobile Spring Shackles and Bolts

**S**PRING shackles, or hangers, are good examples of automobile parts that are obscured by other parts so that they are sometimes overlooked or forgotten when oiling time comes. These joints form the connecting links between the springs and the frame, and they must support the weight of the frame, motor, body and passengers. The length of the spring varies with the degree of deflection, so that the spring shackles swing back and

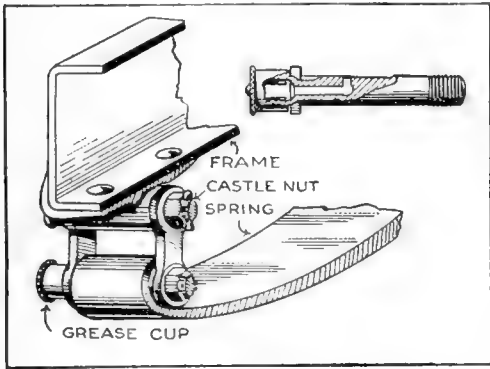

Grease is forced through a hole drilled in the bolt that secures the cup in its place

forth, developing friction at all joints. To prevent the wear on these bearings it is necessary to provide an ample supply of lubricant. These joints are partly, if not wholly, covered by the front and rear fenders, and failure to care for them properly is often the cause of annoying squeaks and rattles.

A simple method of lubricating them employs the grease-cup as illustrated in the drawing. A small hole is drilled in the bolt connecting the grease-cup with the center of the bearing surface. The grease is forced through this hole to the bearing surfaces when the cup top is screwed down. The cups should be filled with a good cup-grease and then turned down until the lubricant is forced out to the bearing. This should be done after every 500 miles; or, better still, on a certain set day each week. At least once a season the spring bolts should be removed and thoroughly cleaned. The hole through which the grease is fed should be cleaned out with a wire and flushed with gasoline.

A Pocket Flash-Lamp on the Bicycle-Handlebar

**A** SIMPLE and inexpensive bicycle light may be made by welding together two hose-clamps, such as are used on garden hose, one clamp being fastened to the handlebar and the other to a pocket flashlight, as shown. The two clamps should be riveted together and then welded with oxy-acetylene or brazed. A flashlight mounted in this way gives very good service.

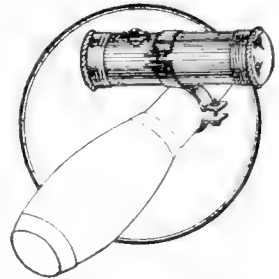

Two hose-clamps on a flash-lamp holder

Fillers for the Pedal Slots of Automobiles

**T**HE front seats of an automobile, while highly prized by everybody, are not usually the most comfortable, because in summer the heat of the motor is felt through the floor-board and in winter the cold is more perceptible there. This is especially true of the Ford car, which has four large slots in the floorboards, where the pedals and brake-lever are located.

To close these slots a simple filler plate has been devised, which fits under the floorboards and holds a piece of rubber over the openings. The rubber sheet is slit to allow the shanks of the pedals to pass through so as not to interfere with their operations; but the slits are barely long enough to serve their purpose

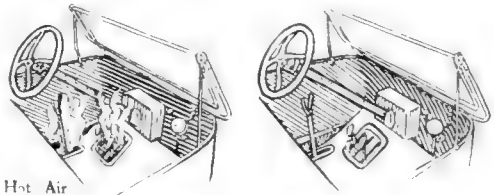

Hot Air Currents

Slots of a pedal plate covered by a rubber sheet so as to prevent unpleasant drafts

leaving no space for air to enter.

Asbestos felt boards may also be used to insulate and make draft-proof the under sides of the floor-boards.

Estimating the Speed of Passing Automobiles

YOU can calculate the speed of passing automobiles, without leaving your house. Measure off 132 ft. on the street, marking each end with slacked lime. With a little practice, it will be possible to note, on the dial of a watch, the exact time taken in traversing this distance. The following table shows the rates of speed:

Sec.	.....	.....	.....	.....
1	.....	90	miles	per hour
1½	.....	60	"	"
2	.....	45	"	"
2½	.....	36	"	"
3	.....	30	"	"
3½	.....	26+	"	"
4	.....	22+	"	"
4½	.....	20	"	"
5	.....	18	"	"
5½	.....	16+	"	"
6	.....	15	"	"
7	.....	13	"	"
8	.....	11+	"	"
9	.....	10	"	"
10	.....	9	"	"
11	.....	8+	"	"
12	.....	7+	"	"
14	.....	7+	"	"
15	.....	6	"	"
18	.....	6	"	"
20	.....	4½	"	"
22	.....	4+	"	"
25	.....	3½	"	"
30	.....	3	"	"
45	.....	2	"	"

A series of tests showed the average speed of an automobile to be 6 sec.; horse trotting, 14 sec.; a man walking, 30 sec.; a woman walking, 45 sec.—D. L. MERRILL.

A Practical Pulverizer Made From a Cutter-Bar

THE illustration shows a pulverizer to crush clods and pulverize the ground. It consists of a cutter-bar taken from an old binder and bolted to the front member of the ordinary road drag. The bar is placed at an angle so that the trash will not hang upon it. The guards of the bar will penetrate the ground, break up the clods and smooth the ground very satisfactorily.

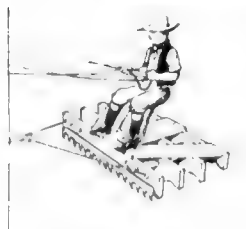

Binder cutter-bar on front crosspiece

Making a Sediment Pocket in Feed Line to Carburetor

NO MATTER how carefully fuel is filtered when filling the automobile or motor-boat tank, a certain amount of impurities will be poured in with the gasoline, which the ordinary fuel filter using wire gauze screens does not prevent from reaching the carburetor. While a screen will retard lint or scale, it will permit particles of rust or small drops of water to pass through. If the gasoline pipe is joined to the carburetor with an elbow, as shown at A, the dirt or water

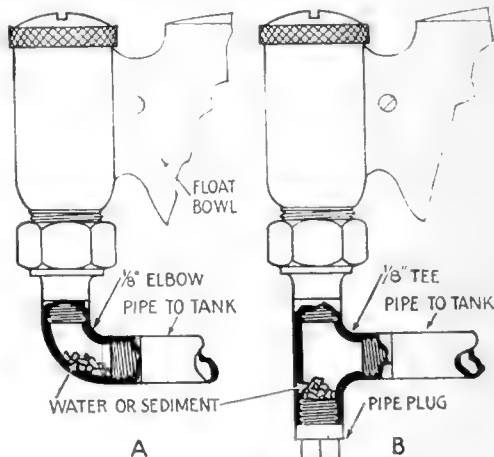

A tee joint in the line below the carburetor forms a place to catch the sediment

is apt to collect, resulting in erratic engine operation because the flow of gasoline is impeded and at times interrupted altogether.

The method shown at B is a superior one. A tee-fitting is used instead of an elbow and the open end is plugged with a standard pipe plug. Impurities then collect in the bottom of the tee instead of flowing into the carburetor or constricting the passage. A piece of pipe 1 or 2 in. long, capped at the end, may be substituted for the pipe plug. This gives a larger sediment chamber; or a standard petcock may be used at the bottom of the tee, providing a means of drawing off the dirt readily.

THE value of millstones produced in the United States dropped from two hundred thousand dollars in 1880 to forty-three thousand dollars in 1915.

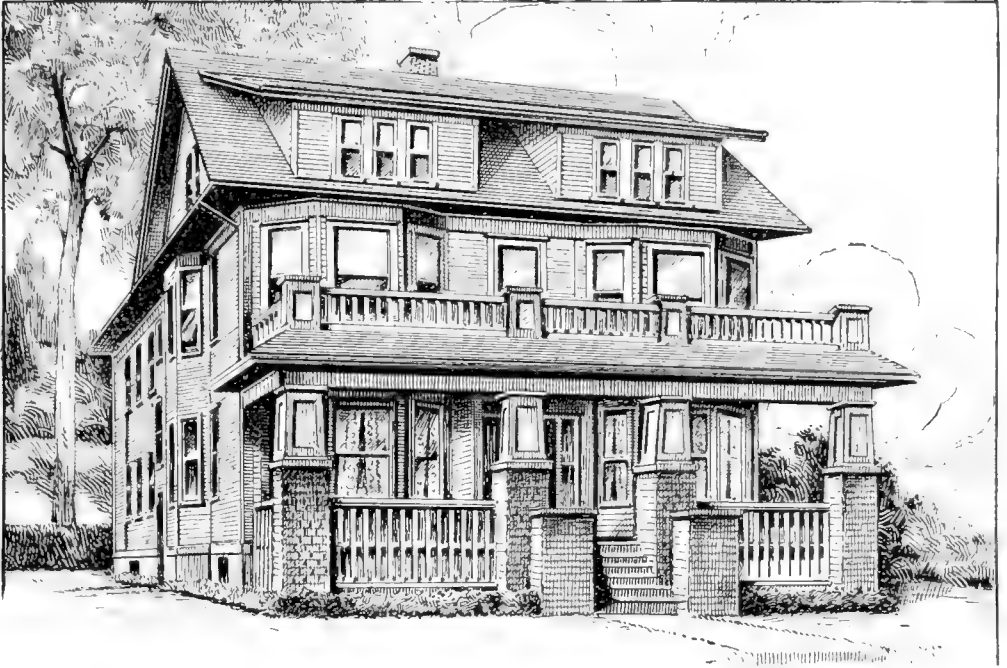

# A Four-Family Apartment House

By George M. Petersen

THE four-family apartment house, and apartment houses in general, are, properly speaking, tenement houses and are so classed under the rules of the Board of Health and Bureau of Buildings in most of the cities of this country. While the origin of the four-family apartment is somewhat mysterious, it was probably designed by someone who wanted the class of tenants known in the large cities as "flat dwellers" and who also wanted more rents than could be obtained from a two-family house. The modern four-family apartment is nothing more nor less than two two-family houses joined together on a common wall.

The wall dividing the house in the center is of either fireproof or fire-resisting material; such as hollow tile, old brick, concrete blocks or stone, although the hollow tile is the most commonly used. This fireproof wall extends the entire length of the house and from the cellar floor to the ridge of the roof without an opening of any kind except

a fire-door in the cellar and the entrance doors to the apartments.

The building shown in Fig. 1 is 32 ft. wide by 72 ft. long and is built on a lot 55 ft. wide by 160 ft. deep.

The living-rooms and dining-rooms in this house are finished in a fumed oak effect, while the bedrooms and bathrooms are either natural oak or white enamel. The rear halls may be finished in the same kind of wood as that used for the bedrooms.

Bathroom floors should be of hard lozenge tile to prevent the absorption of water, but should never be glazed, as the constant wear and tear to which the average bathroom floor is subjected will crack the glaze and disfigure the floor.

The floors throughout the remainder of the house should be of oak, with the exception of the kitchen floor, which may be of maple.

With a properly constructed house a four-family apartment is as desirable as is a two-family flat and has the advan-

tage of being more economical to heat, especially the lower floors. For this type of dwelling, the individual plant is the most satisfactory. In Fig. 2 is shown

from one part of the house to the other. The floors in the living-room and dining-room are of  $\frac{3}{8}$ -in. tongue and groove "select" oak, while the remainder

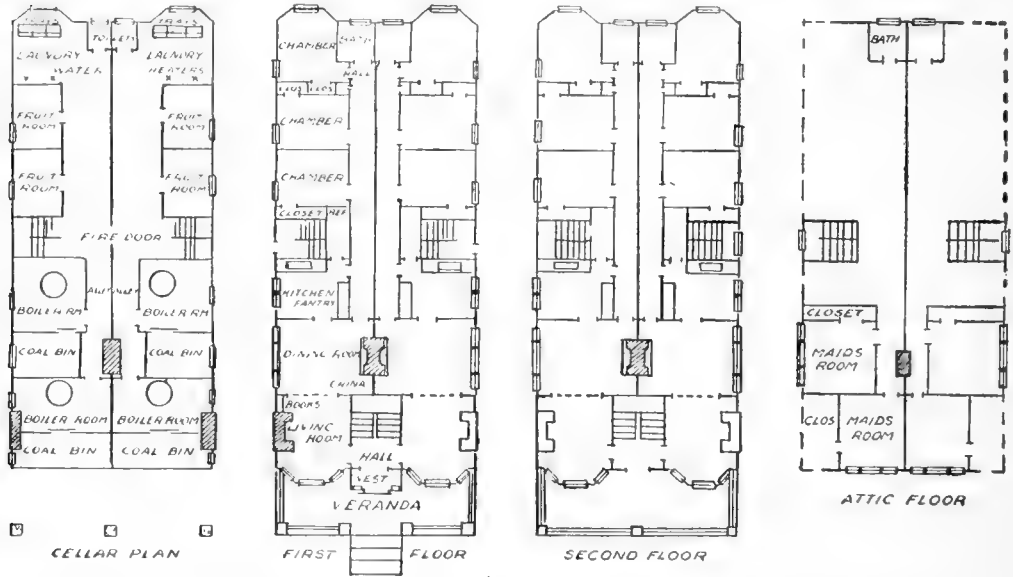

Fig. 1. Plan of a four-family house in which every room is an "outside" room and each apartment is self-contained, even the cellar being divided into separate compartments

a plan of a cheap four-family apartment such as is usually erected in the less restricted sections of a city. This house is 10 ft. narrower than the one shown in Fig. 1. Although the buildings are the same length, exclusive of verandas, the plan shown in Fig. 2 is considerably cheaper to erect, not only on account of the 10-ft. saving in width but because of the perfectly plain roof and other differences where cost is the chief consideration.

The foundations of this house are of concrete blocks laid on a 6-in. footing of concrete. The fire-wall divides the house in the middle of its length instead of the center of the width as in Fig. 1. This fire-wall must be constructed in the same manner as is the wall in Fig. 1, extending from the foundation wall to the ridge of the roof without openings of any kind through which fire could communicate

of the flooring is  $\frac{7}{8}$ -in. tongue and groove yellow pine. The kitchens are wainscoted with  $\frac{3}{8}$ -in. yellow pine, 3 ft. high, and finished at the top with a suitable cap, while the bathrooms have a 4-ft. wainscot of stamped metal tiling.

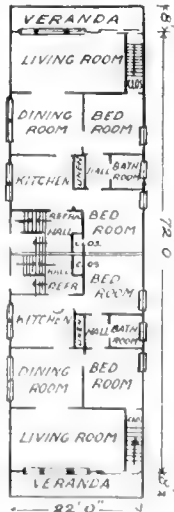
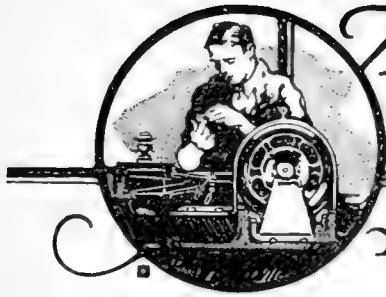

Fig. 2. The cost of this house is comparatively small

The refrigerator space is provided in the rear-stair hall, a galvanized iron pipe being placed in the partition so that the water will run away into the floor drain in the cellar. As will be noted from the plan, this house is provided with two verandas, each of which has a deck for the use of the second floor tenants, the decks being covered with canvas, which is much more satisfactory and durable than tin.

In the basement of this house are four hot-air furnaces, and instead of the automatic water-heaters of the more expensive plan, thirty-gallon range boilers are installed in each kitchen.



# The Amateur Electrician

## And Wireless Operator

### An Improved Coil Winder for Electrical Apparatus

COIL winding is a very difficult operation for the amateur, especially where it is desired to have the outside surface smooth and neat. To do it correctly the spool upon which the wire is wound must be revolved at a medium speed while the wire is fed on with a guide or by hand.

The work of winding some coils 10 in. long was quickly accomplished by the aid of a machine made as shown in the illustration. Two trestles were used to which a baseboard or ways of the devised lathe were attached. The tail-stock consisted of a wood block fastened to the ways with a bolt having a thumb-nut on the underside. The block was bored centrally near its upper end and a bolt placed in it with a waste nut screwed to one surface for the feed. A hand-wheel found in the scrap served to turn the bolt. The end of the bolt was filed down to a point for the dead center.

The lathe-head consisted of a breast drill attached with clamp-bolts to a piece of the proper height fastened to the opposite end of the ways. A spur center was used in the drill-chuck for turning the spool. Spools of varying lengths can be placed between these centers and turned by means of the crank on the drill.

In winding the coil the ordinary wood rest can be used as a guide for feeding the wire.—WILLARD GEORGE COOK.

### De-Sulphating Storage- Battery Plates

ONE of the chief causes of loss of efficiency in lead accumulator cells is sulphation. White sulphate of lead usually forms on the active material and at a point where it is least wanted—at the junction of the metal supports and the peroxide. The formation of this sulphate is due either to the impurities in the oxide employed, foreign substances in the lead or lead alloy, or chemical impurities in the sulphuric acid or water.

One way to remove the sulphate is to charge at a somewhat higher rate than normal and to continue charging some little time after the cells are gassing freely. This method either reduces the sulphate to the peroxide or causes it to fall away from the plate.

A quicker and more satisfactory way, however, is to add about 1 oz. of sodium carbonate ( $\text{Na}_2\text{CO}_3$ ) to each cell. This not only reduces the tendency of the elements to sulphate, but rapidly removes the salt that is already formed. If

the amount mentioned does not result in removing the sulphate, another ounce can be added to each cell; but no more than this should be put in. Unless the cell is in a very bad condition 1 oz. will usually do the work. After putting in the sodium carbonate, the cell or cells, should be charged at a rate of from 13 to 15 amperes for 8 hours.

The de-sulphating solution should be mixed with a varying amount of water, de-

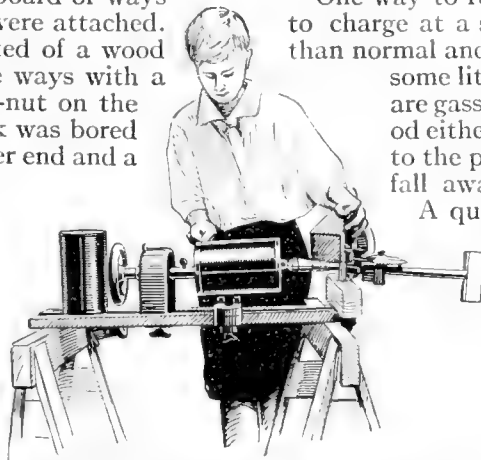

Winding an eighteen-inch coil on an improvised lathe made of a breast drill

pending upon the form of the salt. If the crystallized salts are secured, they should be mixed with 1 part of salt to 2 parts of warm water. If the dry salts are used, 1 part of salt should be mixed with 5 parts of warm water. It is best to mix the solution immediately before using.

If storage-cells have been idle for some time and have become badly sulphated, the following treatment will ordinarily put them in condition for service again. First, the jars should be thoroughly cleaned and the plates dusted, after which the cells can be assembled and the jars filled with electrolyte, having a specific gravity of about 1.215. Cells can then be charged at 15 amperes for about 2 hours, after which  $\frac{1}{2}$  pt. of a strong solution of sodium carbonate mixed with 1 part of salt to 2 parts of water can be added. If the cells have been standing idle for a great length of time it is better to mix the solution with 1 part of salt to 1 part of water. They should then be charged at a rate of from 12 to 15 amperes for 8 hours a day for 2 consecutive days. The plates will look to be as good as new after the sulphate has been removed by this method. It is better to remove the de-sulphating solution after the plates have been brought to a healthy condition and replace it with the ordinary electrolyte.—A. GEMMELL.

#### Insulated Plier Handles with Fuse Cases

**E**LECTRICAL men are often called upon to make taps or splices on wires carrying current. For this work they need insulated plier handles. A simple method of making these is shown.



Fiber tubes driven over plier handles to form an insulation for electrical work

Take two fiber tubes such as are used in 600-volt fuses of about 30 amperes capacity. These can be forced over the handles if they are driven by light blows of a hammer. A fiber or wood plug is inserted in the ends and then

shellacked or compounded. The result is a very good pair of insulated pliers.

#### Making an Alternate Current Buzzer From Old Bell Coils

**T**AKE two old bell coils and mount them on a wood base. Also secure a piece of heavy clock-spring

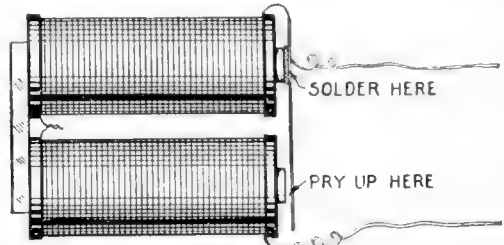

Buzzer made of old bell coils to work on alternating current

long enough to reach from one core to the other. Solder one end to one core and with a knife pry the other end so it will not touch the core. Join the inner wires of the coils together and the instrument is complete.—CHARLES LOOMIS.

#### A Home-Made Flood-Light Projector for Construction Work

**T**HE accompanying illustration shows a home-made flood-light projector with the reflector made of an ordinary tin pan. The tin is large enough to permit using a 500-candle-power nitrogen-filled lamp, which is mounted in the center, as shown. The tin pan is supported by means of a  $\frac{3}{8}$ -in. gas pipe in such a way as to permit adjustment of the projectors up and down through various angles. The two pipes in the front of the projector are fitted with sleeves and two wing-screws, which permit them to be shortened or lengthened. The rear pipe is arranged with a universal joint, which acts as a hinge. The universal joint could probably be dispensed with by using a loose tee at the bottom of the rear pipe.

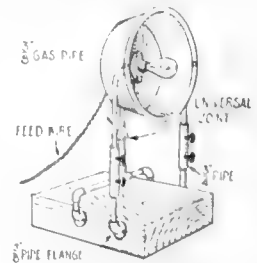

A flood-light for night workers

The tin pan is supported by means of a  $\frac{3}{8}$ -in. gas pipe in such a way as to permit adjustment of the projectors up and down through various angles. The two pipes in the front of the projector are fitted with sleeves and two wing-screws, which permit them to be shortened or lengthened. The rear pipe is arranged with a universal joint, which acts as a hinge. The universal joint could probably be dispensed with by using a loose tee at the bottom of the rear pipe.

# How to Become a Wireless Operator

## III.—The Construction of a One-Mile Receiver

By T. M. Lewis

IT IS most important for a student of wireless telegraphy to learn all about the operation of the various forms of receiving apparatus. The best way to become familiar with the instruments is to build and operate them. The simple buzzer-sender and microphone receiver which were described in the first article of this series served to illustrate the principles which are followed in all wireless apparatus, but were of such small signaling range that they could not demonstrate fully the details of modern instruments. The one-mile transmitter shown last month, however, when used in connection with the receiver now to be explained, is of sufficient size to approach the conditions of operation existing in commercial radio stations. By studying its action carefully the experimenter can learn much which will be of inestimable value to him in his later practice of wireless telegraph operation.

The student should remember that the use of a transmitter as powerful as that described in the second article, even though it is a very small one when compared to some of the great commercial plants, may cause interference at nearby receiving stations. He should therefore be very careful to observe all of the regulations and courtesies as to transmitting, and should send only when he actually has a message which he wishes delivered to his communicating station. One of the first habits which a successful wireless operator should cultivate is to refrain from sending except when it is absolutely necessary. Testing of the spark-gap should be done with

the aerial disconnected, and code practice should be carried on with buzzers. There is never any objection to the amateur who sends actual messages with a wavelength of less than 200 meters (the range assigned to amateur stations by the Government) but the man who keeps tapping his key and sending out interfering waves which hold up legitimate messages soon becomes extremely unpopular with both the serious amateurs and the professional operators.

### *The Detector*

Probably the most important element of any receiving outfit is the detector, which is an instrument for converting the received high-frequency current into pulsations which operate the telephones. The microphone which was described in the first article is a wave-detector of a very easily constructed type, and is always worth remembering

for use in an emergency. It is very delicate, but is not so reliable nor so sensitive as the crystal detector which is illustrated in Fig. 1. A well made crystal detector is about the best instrument for all around use that can be had. Apparatus of this type is installed at by far the greatest number of commercial radio stations, and every operator should be familiar with its adjustment and use.

A side view of a detector-stand, which has been found very satisfactory in practical work, is shown in Fig. 1. The construction should be clear from the drawings, and a brief description. Dimensions are not given, since it is usually most convenient to modify them slightly

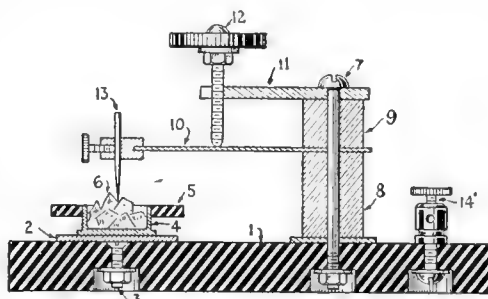

Fig. 1. A cross-sectional view of a crystal detector stand that is easily constructed



to suit whatever material may be on hand. The base 1 may be made of hard rubber, fiber or hardwood, and should be about  $4\frac{1}{4}$  in. by 2 in. by  $\frac{1}{2}$  in. thick. Four holes to take 8-32 machine screws

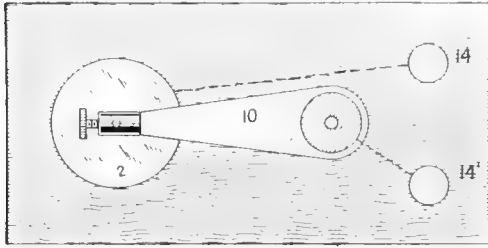

Fig. 2. Plan view showing the mounting of the spring brass that holds the needle

are drilled in the positions shown in Figs. 1 and 2 and directly beneath the parts and are counterbored from the bottom to about  $\frac{1}{4}$ -in. depth to take the nuts and washers. A disk 2, of copper or brass about  $\frac{1}{16}$  in. thick and  $1\frac{1}{4}$  in. in diameter, is soldered to the head of a machine screw 3 and forms a sort of table on which the crystal-cup may slide. The screw 3 is fastened in place by a washer and nut, as indicated, and is connected to binding post 14 through the channel shown in dash lines in Fig. 2.

A flat brass cup as at 4, Fig. 1,  $\frac{5}{8}$  in. in diameter and  $\frac{1}{4}$  in. deep, may be made by cleaning out thoroughly the cap of a shotgun shell. In this is secured a piece of fused silicon, galena, or other sensitive crystal 6 (which may be purchased from almost any wireless supply house) by melting and pouring in solder around it. The heat of molten solder will partially destroy the sensitiveness of some crystals, so it is better to use Woods' metal or a mercury amalgam if it can be obtained; solder will generally do for silicon, however. A hard rubber or fiber ring 5, about  $\frac{1}{8}$  in. thick, should be forced on over the outside of the completed cup, so that the crystal may be moved around without making contact between the metal cup and the operator's fingers.

A needle point 13 is to be supported directly above the crystal, and this may best be done by the pillar arrangement shown. A long machine screw 7 is passed down through two bushings 9 and 8, and is fastened below the base by

a nut and washer. Between 8 and 9 is clamped a tapered strip of spring-brass 10, to one end of which is soldered a binding-post from the zinc terminal of an old dry cell. The shape of this strip may be seen in Fig. 2, where the upper part of the detector is omitted.

At the top of the pillar is fastened the adjustment arm 11, which should be made of brass about  $\frac{1}{8}$  in. thick cut as shown in Fig. 3. The left hole is threaded to take the pressure-adjusting screw 12, Fig. 1, and is slit as indicated at 15, Fig. 3. Thus the screw 12, Fig. 1, may be held snugly by the screw-threads. A hard rubber or fiber hand-wheel should be affixed to the top of 12 by a washer and nut, as in Fig. 1. Connection is made from the screw 7 to binding-post 14' by way of the shorter channel indicated by dash lines in Fig. 2.

### The Telephones

Next to the detector, the most important thing in the receiving station is the telephone. Any ordinary telephone-receiver will give some sort of results, but to get the loudest signals for any particular set of conditions the best telephones should be used. There are on the market a number of head-receivers, designed for wireless telegraph use. These are usually mounted in pairs, one for each ear, on a flexible headband, and are wound for resistances higher than ordinarily used in wire telephony. Reasonably good results can

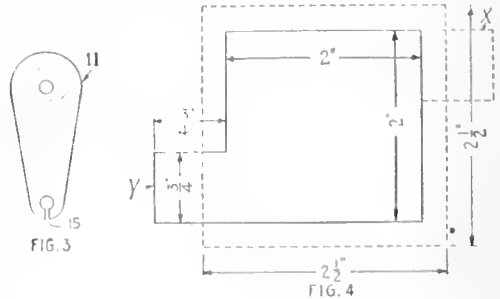

Fig. 3. Plan of the adjustment arm

Fig. 4. Detail of pattern of the tinfoil

be secured from two ordinary 75-ohm watchcase receivers, if they are connected in series and mounted upon an improvised headband. Thus, there is no need for any one to be discouraged

by the high price of the most expensive types. It is good policy, however, for the student to invest as much as he can spare in good telephones, even if a saving must be effected by cutting down the size of the transmitter.

*The Blocking Condenser*

Another essential part of the receiving apparatus is a blocking condenser, which is used to prevent the tuning coil from

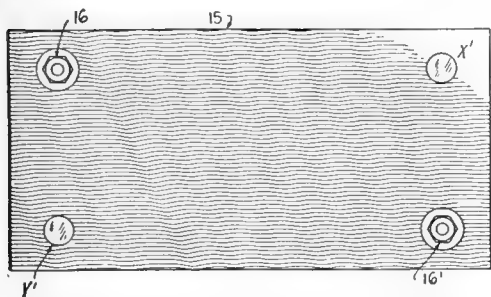

Fig. 5. One of the holders for the condenser made of hard rubber, fiber or wood

short-circuiting the detector or telephones. Such a condenser as shown in Figs. 4, 5, and 6 may easily be made. A "fixed condenser" may be purchased from any wireless supply store, but it is a good plan for the experimenter to make one. By doing so not only is the actual construction of the instrument learned, but the weak points which might cause trouble later are located.

A pattern for the tinfoil sheets is cut as shown in Fig. 4, 2 in. square but each having a lug  $\frac{3}{4}$  in. square at the corner. Thirty of these will be needed for the condenser. It is also necessary to cut out about thirty-five sheets of thin paraffin paper  $2\frac{1}{2}$  in. square, as shown by the dash lines in Fig. 4. The condenser is begun by placing a sheet of paraffin paper upon a flat surface, and putting on top of it one tinfoil sheet with the lug at the lower left corner, as shown by Y in Fig. 4. On top of this foil is placed a sheet of paraffin paper, and upon it a second sheet of foil; this time the lug is turned to project at the upper right corner, X (dotted lines) in Fig. 4. Then a sheet of paper is added, and upon it a third piece of foil with its lug in the Y (lower left) position. Another sheet of paper is put in place, and then a fourth piece of foil with its

lug in the X position. Thus paper and foil are alternately added, and the position of the lug changed each time. The result is a pile of thirty sheets of tinfoil separated by thin paraffin paper, fifteen lugs projecting to the left and the fifteen alternate lugs projecting to the right. Care must be taken that none of the alternating sheets of foil touch each other, since this would short-circuit the condenser.

A holder for the paper-and-foil condenser is made by cutting out two pieces of  $\frac{1}{8}$  in. or  $\frac{3}{16}$  in. hard rubber or fiber or hardwood about  $2\frac{3}{4}$  in. by 4 in., and drilling four holes in each as shown in Fig. 5. An 8-32 machine screw is passed through each of these holes, washers being placed between the clamping pieces in such number that the condenser is firmly gripped. The upper right and lower left screws X' and Y' clamp the groups of tinfoil lugs X and Y, as shown in Fig. 6, and the binding posts X'' and Y'' mounted upon their upper ends serve to make electrical connection. The other screws 16 and 16' are merely for mechanical strength.

When the condenser is finished, paraffin may be melted and poured in to fill the entire space between the two clamping plates. If the construction has been careful and if the condenser is in good condition, when a dry cell and telephone are connected in series with the binding posts X'' and Y'' only a very faint click will be heard as the circuit is made and broken. If the condenser is short-circuited (and therefore useless until repaired) the telephone will click as loudly with it in series as when connected directly across the dry cell.

*Additional Apparatus*

In the next article there will be described the buzzer-testing arrange-

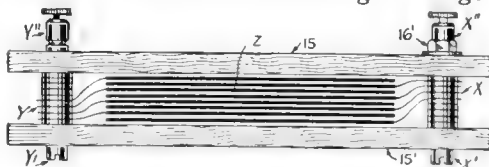

Fig. 6. The holders with foil and paper between them and binding posts on one surface which is used to adjust the crystal-detector to its sensitive receiving con-

dition, and a complete wiring diagram for the entire transmitting and receiving station will be given. The manipulation of the apparatus, the methods of calling and answering and of sending messages, as well as the construction and use of the antenna change-over and the detector-protecting switches will be discussed. The remaining instruments needed for the receiver are even easier to construct than the detector and condenser outlined here. It would be a good plan for the experimenter to complete his transmitter (as described last month) now and the apparatus shown in this article, so that he will be all ready to put his station into complete operation soon after the appearance of the next article. It should be remembered that for exchange of messages between two stations it will be necessary to build two of each of the instruments described, so that each station may be completely equipped and thus prepared both for sending and for receiving.

#### Caring for Storage-Batteries on Automobiles

**A** WEAK or exhausted battery will cause misfiring in an engine, be-



sediment, destruction of insulation and the buckling of the plates; or, perhaps too little attention is given to the recharging requirements which vary with the use of the car. It is best to analyze the character of the driving before finding fault with the battery to see if a too great demand has been made upon it. A doctor or a city salesman, making many stops, will consume more current than the battery will stand, due to the frequent cranking. Continued use of a car at night will place an added burden on the battery to light the lamps, which may equal or exceed the output of the generator going at the speed one travels at night. Under these conditions a battery may be in a completely run-down or discharged condition when tested in the morning. The specific gravity of the electrolyte may drop below 1.150. One of the chief causes of battery exhaustion is excessive cranking.

The hydrometer syringe is used in the manner illustrated in making tests for specific gravity. When refilling the cells with fresh distilled water or putting in a new solution squeeze the bulb, and place the rubber tip in the receptacle containing the solution. The bulb is then released, and the liquid is drawn into the glass tube. Insert the tube in the vent hole of the battery, and squeeze the bulb lightly to eject enough of the contents to fill the cell. Release the bulb and quickly turn the tube to a horizontal position, to keep the solution from dropping on the upper surface of the battery. Press the bulb to expel the remaining liquid, replace the vent plugs and wipe the moisture and dirt from the top of the cell.

To test the specific gravity, draw in enough liquid to fill the syringe and hold it toward a light. The floating part will show the density by the graduations.

#### Discarded Type-Cases in the Amateur's Shop

**D**ISCARDED type-cases, obtainable from any printer, can be put to excellent use in the shop of the amateur mechanic. Such cases may be used for keeping screws, nuts, bolts, washers, etc., where they can be easily found. Fasten two or three of them under the work-bench where they will be within easy reach.

**A New Method of Reviving Old Dry Batteries**

**N**OW that all sorts of electric pocket flashlights and electric lanterns are common, it is worth while to know that the batteries for them need not be thrown away immediately after the light loses its original brilliancy. When

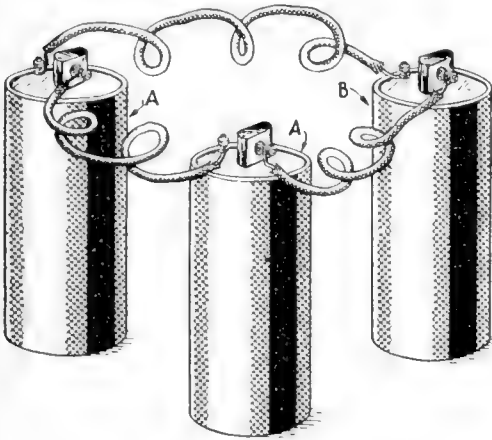

Three partly exhausted cells are connected, two in series and the third across terminals

a dry cell is so far exhausted that it produces nothing more than a quickly-fading glimmer of light, which it would ordinarily keep at full brilliance, it is usually discarded as worthless. Such batteries may, however, be set aside until a number of them have accumulated; and some of them may be used to revive the others by the following method, which is applicable to the dry battery because it possesses, to a certain degree, the property of reversibility.

When three partly exhausted cells have been accumulated, connect two of them in series, and the third one across their terminals in reverse series, as shown in the drawing. When this is done, it will be seen that the electromotive force of cells *A* will more than balance that of cells *B*; and a small current will flow through the entire battery, passing through cell *B* in the reverse direction from normal. The reversed cell, therefore, becomes virtually a storage cell, and slowly takes on a charge from the other batteries. After being left in this position for a few days, cell *B* may be disconnected and again used in the regular way. A

cell thus revived will be as good as new. More than three cells may be connected; for example, three cells *A*, may be set to reviving two cells *B*; in which case the action will be slower because the electromotive force of the odd cell, *A*, must overcome the internal resistance of five cells instead of three, as in the first case.

Old dry cells for any other purpose may be revived in the same way. They may be tested for exhaustion by connecting them to an ammeter or to some piece of apparatus such as a bell or telegraph-sounder, and comparing the effect produced by one of the old cells with that produced by a fresh cell when connected to the same. As an ammeter puts a cell on practically a short circuit, it should be used quickly to avoid further exhaustion of the strength of the cell. The property of reversibility is not possessed by all types of primary batteries; and it must be borne in mind that this article has reference only to the dry cell.—EDWIN C. WRIGHT.

**A Home-Made Fuse for a Small Battery Current**

**T**HE beginner in electrical science who wishes to demonstrate the action of a fuse on a small scale will find the following a suitable form to use. Make a little wood block *A*, 2 in. long by 1½ in. wide, and fix two brass springs, *B*, one at either end. The screws used to secure these also serve for the attachment for connecting wires. Take a 1-in. length of glass tube, *C*, and cork both ends, pasting a very

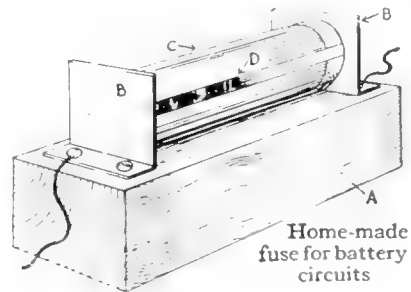

Home-made fuse for battery circuits

narrow strip of tinfoil *D*—¼ in. or less—along the side and covering both corks with a wider piece of foil. The tube can then be gripped between the springs. This forms a good fuse for small currents.

# Amateur Trench Electricians

How the soldiers in the French trenches utilize shell cases, brass scraps, and old muskets to spy electrically on the enemy

By George Kenneth End

IN a bombproof dugout under an auxiliary station not far from Fort Tavannes in the Verdun theater of the war, an electrician has installed a crude little wireless apparatus.

This young Edison of the trenches is the leader of a group of expert electricians assigned to one of the most difficult and most dangerous jobs on the front. The laying of wires from the "*poste d'écoute*," "listening station," to the switchboards further back of the lines, the wiring of underground mines so as to afford illumination for the soldier toilers under earth, and constant vigilance over the wires which might at any moment be cut by exploding shells, is his job.

It is useless to lay wires underground along the Verdun front, so three wires are strung for every line connection. These lines are strung from small posts about 7 ft. above ground, the several units of the same line being as widely separated as possible. Thus the chance of having the circuit broken is made comparatively small.

At this particular switchboard, which was about 15 ft. underground, there was telephonic connection with about eight different points along the first lines. Every 20 minutes each of the lines was tested by the operator at the switchboard. When a line was found to be cut a squad of four men was sent out at once to locate the fracture and repair it. They might be called upon at any time of the day or night, for very often when the enemy is concentrating a curtain of shell fire over a section information as to activities in the first lines would be absolutely cut off if it were not for the telephonic communication. Most of the lines are hung parallel to the roads, where they are, of course, exposed to shell fire more than they would be if laid across the fields. The main consideration, however, is to have them accessible to the linemen.

It is not shell fire alone which brings

down the telephone wires along the front. The closer to the lines, the cruder becomes the method of hanging the wires; so that a small windstorm or even rain (which invariably follows a heavy bombardment) may put the wires out of commission.

The electrician in question, who had been in this particular section of the Verdun front during four months of the great battle, constructed during his spare moments a device for electrically eavesdropping in the enemy's trenches. For the success of the device he was decorated with the *Croix de Guerre*. He had very little equipment at his disposal, so he utilized, for the most part, pieces from the artillery scrapheap. Through the use of his trench dictaphone several gas-attacks of the enemy were apprehended in time to make preparations against them.

During the night the electrician arranged in the enemy's barbed wire a series of discharged "75" shell-cases containing microphones, to which he connected wires terminating in the French trench where batteries furnish current for reproduction of the sound waves on telephone receivers. A ground connection is made to carry the "return" current.

It is true that the closer one gets to the front the less general becomes his perspective of the war. The men in the first line trenches see the war sifted down to the few feet of trench where their guns are resting. News from other parts of the front is generally 48 hours late in reaching these men. If a soldier who has been holding down his few feet of trench at Verdun is assured that his countrymen on the rest of the front are doing the same he is much encouraged. This electrician has made it possible for them to receive the daily *communiqué* an hour after it is transmitted from the great wireless station of the Eiffel Tower in Paris. He did some more rummaging

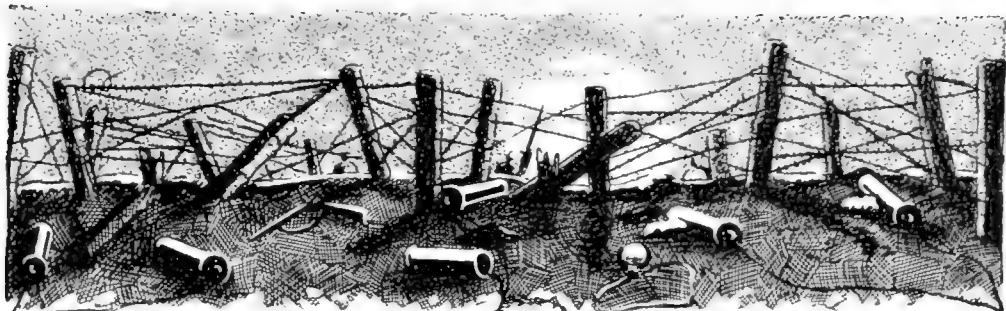

around the artillery scrap-heap, detached a few parts from an old musket, cut some strips from a brass "75" shell-case, bought a small piece of detector-crystal, and in a short time was sending a messenger out soon after midnight every night to take to the men in the first lines the day's news.

At midnight of the date of the interview the *communiqué* was a long one, being the first news of the French offensive in Picardy which had just begun. A messenger took the glad tidings back to his brothers in the trenches. Then the electrician adjusted the instrument so that it intercepted messages sent out by some German portable field wireless apparatus. The German spark is pitched very high and musical, while the French is dull and staccato. A message sent out from an aeroplane was intercepted also by the crude but practical receiving instrument.

For military purposes the wireless is not used as much by the French as by the Germans. The French, wherever possible, use the telephone instead; and along some parts of the front they have established underground lines impregnable to shell fire. The French have closed automobiles equipped with complete telephone switchboards, so that temporary exchanges may be established at short notice wherever they may be needed. Where the portable wireless is used on the French front it is carried on a motor-tricycle affair so that it may be taken very close to the first lines.

In the recent offensive on the Somme electricity was a very potent aid to the French success. The village of Dompierre, which before the offensive was in the hands of the Germans, had been mined by the French from one extremity to the other. The principal excavation



under the village had an area of some 50 square meters (about 500 sq. ft.). It was a task which took the French over two months to accomplish, for there were immense difficulties encountered in the way of avoiding enemy mining parties and transporting material necessary for making the work secure. As the work progressed, electric wiring was installed for illuminating the dark recesses of the excavation. Finally the large cavern of the mine under the village of Dompierre was stored full of explosives—enough, in fact, to blow the entire village to atoms. Electric fuses were installed, from which underground wires led back to General Headquarters. Thus the general of the division, by pressing a small electric button ten kilometers distant, blew up the German village of Dompierre. He heard the explosion five seconds later and knew that the first stroke of the great Picardy offensive had been a success.

#### A Simple Plan to Avoid Clouded and Grimy Ceilings

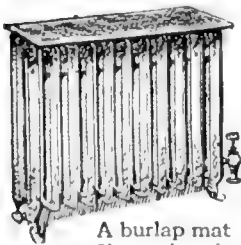

**I**N many residences and public buildings where hot water or steam radiators are used, the wall above and behind the radiators and also the ceiling above them eventually become clouded and grimy.

Why? Because the air of the rooms is drawn to these warmest points, rising between the coils and going directly upward before spreading out to circulate through the rest of the room. As they strike the wall and ceiling the columns of warm air deposit their dust.

A remedy was found by one house-keeper who made simple mats or covers of coarsely woven burlap in colors to harmonize with the furnishings. Placed on the radiator these open-weave hemmed cloths allow the air to rise through them, but sift or filter out the dust, which is removed by an occasional washing.

#### To Prevent Asphaltum in Cans from Evaporating

**A**SPHALTUM is used extensively about electrical apparatus and where anyone has to do with the making up of coils, and the like, a can of this material will be found at hand. The brush and liquid will likewise be found in a condition that renders them unusable until thinned with drier. Just an ordinary oil-can makes a convenient holder for the liquid and brush. The handle of the brush is inserted in the spout, as shown, where it keeps the brush part in the liquid. Air cannot enter, hence there is no evaporation. This holder is especially useful for the home work-shop where the asphaltum is used only occasionally and is kept in small quantities. The brush is kept soft and in a workable condition.

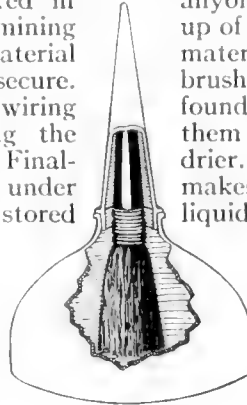

The paint brush suspended within the oil-can holder

#### Making an Inductance Switch for Radio Work

**W**HEN using switches it often happens that trouble is found in making connection to the lever. Soldering is about the best method, but it is often inconvenient. By using the device shown in the sketch this trouble will be avoided.

In the drawings, *A* is the regular brass arm of the switch; the arm *B* is

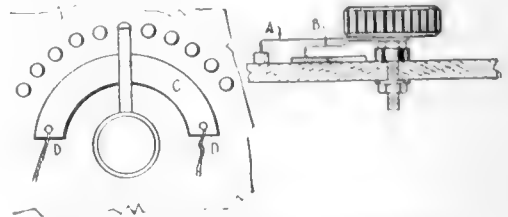

Small switch made of brass strips to form connections to the lever contact points

fastened directly under the arm *A* and revolves with it, so that when *A* is on a switch point *B* is making contact with the brass strip *C*.

The piece *C* may be cut from sheet brass or copper. It is held to the board by the posts *D* from which the connection is taken.



# What Radio Readers Want to Know

## Interesting and Instructive Questions and Answers

### Construction of a Transformer; License for Experimental Station; Operation of Alternating Current Arc Sets

E. D., St. Joseph, Mo., inquires:

**Q. 1.** Please give the details of construction for a 1-K.W. open core transformer and advise how far I may expect to send with it?

**A. 1.** An efficient transformer that will give a secondary voltage of about 18,000 when connected to a 60-cycle source of current supply may be constructed in the following manner: Assemble a core 3 in. in diameter, 25 in. in length, composed of a bundle of wires about No. 30 B&S gage. Care should be taken to secure the best grade of Norway iron. The core is then covered with two layers of Empire cloth after which it is wound with two layers of No. 10 D.C.C. wire, each layer having 220 turns. The entire primary winding is then inserted in a hard rubber or micanite tube and properly mounted on end supports. The tube should have  $\frac{1}{4}$ -in. walls.

The secondary winding is composed of a number of pancakes, the inside dimensions of which are  $\frac{1}{8}$  in. greater than the primary tube. The secondary winding is then composed of 38 sections,  $\frac{1}{8}$  in. in width, each pancake comprising 1,125 turns of No. 32 S.S.C. wire. Just previous to the winding of the individual pancakes the wire should be soaked in hot paraffin. The pancakes are of course separated by insulating washers, such as fiber or hard rubber disks. This transformer may be connected to 60-cycle, 110-volt mains direct, without the insertion of a primary reactance coil. At the restricted wave of 200 meters you will not be able to use the full output of this transformer, as the required condenser for the secondary winding will have a value of approximately .02 microfarads, which is double the value that may be used at 200 meters. This transformer should permit a sending range of 50 to 100 miles during the daylight hours.

**Q. 2.** Under what conditions can a license be secured for the operation of an arc set for undamped waves?

**A. 2.** It is doubtful if the U. S. authorities will issue a license certificate for an experimental station of this type unless the license is requested by an investigator of recognized standing whose work may be of substantial benefit to the art. You had better address your inquiry to the Commissioner of Navigation, Washington, D. C., stating the purpose for which you desire such license. Also keep in mind that arc generators do not operate well at wavelengths below 2,500 meters. Consequently you would be required to operate your station at wavelengths that may interfere with commercial traffic.

**Q. 3.** How far will an arc set having  $\frac{1}{4}$ -in. carbons connected to 110 volts alternating current transmit?

**A. 3.** Alternating current arc sets do not operate satisfactorily and it is feared that you will not be pleased with the results obtained. It is the custom to use 500 to 1,500 volts direct current, but good results can not be obtained by a simple arc gap. The gap must be enclosed in a chamber and fed with hydrogen or illuminating gas and in addition blow-out magnets are mounted at a right angle to the arc to increase the difference of potential. The subject is fairly well discussed in Zenneck's "Wireless Telegraphy."

### Audion Circuits of a "Beat" Receiver; Equipment for a 5-Mile Range; Quenched and Rotary Gaps

J. I. I., Monroe, Mich., writes:

**Q. 1.** Is it considered practical to use an Audion or an Audiotron in the circuits of a "beat" receiver for wavelengths from spark stations lying between 150 and 1000 meters?

**A. 1.** Yes; but it is sometimes found difficult to keep the Audion in oscillation at the lower range of wavelengths. The circuits of the De Forest Ultraudion are said to overcome this difficulty; but with other circuits better results are secured at wavelengths in excess of 2,500 meters. The Ultraudion circuits are published in the Proceedings of the Institute of Radio Engineers.

**Q. 2.** With an aerial 50 ft. in length, 20 ft. in height and an earth wire 100 ft. in length, what range could be expected from the following instruments? A 2-in. coil, 14-volt battery, suitable condenser, small quenched gap and helix. The foregoing apparatus is to transmit to a receiving station comprising a tuning coil, galena detector, 2000-ohm receivers and condenser.

**A. 2.** If the receiving apparatus is well designed, you should be able to communicate to a distance of five miles provided local conditions do not interfere.

**Q. 3.** Is a quenched gap in series with a rotary gap more efficient than the use of rotary gap alone?

**A. 3.** Generally, no; about the only value of this combination is the fact that the rotary gap allows one to obtain a high spark note from a 60-cycle source of current supply. In a well-designed set the quenched gap gives the greater value of antenna current; but for ordinary amateur working the rotary gap fulfills the requirements. In the Clapp Eastham Hytone gap the advantages of both types of spark dischargers are combined in one construction.

### Receiving Wavelength

C. H., Farmington, Conn., inquires:

**Q. 1.** Approximately to what wavelength can I adjust with a tuning coil 20 in. in length, 2½ in. in diameter, wound with No. 30 bare wire? The remainder of the apparatus comprises a condenser, a galena detector and 1500-ohm telephones.

**A. 1.** With the average amateur aerial this tuning coil will permit adjustment to wavelengths inclusive of 6,000 meters, and by the addition of a condenser in shunt to the terminals of the detector circuit, the wavelength can be further increased.

### Damped Wave Reception on Oscillating Audion

J. B. E., Newark, N. J., writes:

**Q. 1.** Referring to the article by W. Ross McKnight in the April, 1916, issue of the *Popular Science Monthly* (page 613) I would like to know if this equipment will respond to both damped and undamped waves, that is, will the equipment respond to ordinary spark stations without change of circuit.

**A. 1.** The receiving apparatus described by Mr. McKnight is applicable to the reception of both damped and undamped oscillations, but is more sensitive with the latter. When the audion is in a state of oscillation, an impure beat-note is produced in the reception of damped oscillations. The result is that the spark note of the distant transmitting stations is distorted, the signal sound being of different character and usually lower than the normal note. The receiver described by Mr. McKnight was built expressly for the reception of long wavelengths and will not give good results on the shorter wavelengths in the vicinity of 600 to 1,000 meters.

### Long Distance Stations

S. W. D., Hamilton, Ohio, inquires:

**Q.** Please give the wavelength, type of transmitting apparatus, and the call letters of as many as you can of the following Transatlantic stations:

**A.**

Name Station	Call Letters	Type of Apparatus	Wavelength (Meters)
Hanover, Germany	OUI	Goldschmitt High Frequency Alternator	7400
Nauen, Germany	POZ	Joly High Frequency Alternator	9400
Eiffel Tower, Paris	—	Damped and Undamped Transmitters, Type Unknown	2500 (for time signals)
Honolulu, T. H.	KHIL	Poulsen Arc Generator	10000
Darien, C. Z.	NBA	Poulsen Arc Generator	6000-10000
Colon, Panama	NAX	Quenched Spark Transmitter	300, 600, 1600
Glace Bay, N. S.	WSS	Marconi Rotary Disk Discharger	7925
Poldhu, England	ZZ	Marconi Rotary Disk Discharger	2800
Tuckerton, N. J.	WGG	Goldschmitt High Frequency Alternator	7400
Siosconsett, N. J.	WSC	500 Cycle Transmitter 2 K.W.	300, 600
Sayville, L. I.	WSL	Joly High Frequency Alternator	9400
New Brunswick, N. J.	WH	Marconi Rotary Disk Discharger	8000, 15000
Lake Bluff, Ill.	NAJ	Poulsen Arc Generator	6000

### Strength of Received Signals Where Connecting Leads Are Long

D. P. D., Limon, Colo., inquires:

**Q. 1.** Will there be any loss in the loudness or in the strength of signals when the receiving apparatus is located 20 to 25 ft. from the lightning switch, the latter being erected on the outside of the building, and the receiving instruments placed on the opposite side of the room to that at which the lead is brought in from the lightning switch?

**A. 1.** No; it is of course desirable to make the connecting lead as short as possible, but the loss in efficiency will not be appreciable.

**Q. 2.** What effect will it have on the strength of wireless telegraph signals if the antenna and ground wires are run parallel; that is to say, are twisted together for a distance of from 20 to 25 feet from the lightning switch to the receiving apparatus?

**A. 2.** The twisted cable will have distributed capacity and will act as a condenser connected in shunt to the primary winding and consequently will occasion a loss in the strength of the signals. It would be better to separate these wires by a distance from 6 to 8 feet.

**Q. 3.** My receiving aerial is 60 ft. in length composed of five wires spaced three feet apart. It points east and west. The lead-in is taken off the east end and extends to the lightning switch which is mounted on the outside of the window of the second floor. The distance from the point where the lead-in is taken off east to the lightning switch is 90 ft. Could I get better results if the lead-in was taken from the center of the aerial instead of from the end?

**A. 3.** For general receiving purposes it had better remain as it is.

**Q. 4.** Will the above aerial be satisfactory to receive from the amateur stations, providing a variable condenser is used to adjust the shorter wavelengths?

**A. 4.** Yes, if the condenser is in series with the antenna.

**Q. 5.** What is the wavelength of this aerial?

**A. 5.** The wavelength is close to 150 meters.

### Simple Method of Remagnetizing Magnets

REMAGNETIZING magnets is a very simple operation for which about 100 ft. of No. 18 copper wire, a 12-volt storage-battery current and a small pocket needle compass are required. Furthermore, the magnet may be tested for strength after it has been removed from the magneto and again tested after it has undergone the remagnetizing process by means of another simple equipment consisting of a block of wood, a bar of iron, a flat iron-plate, a spring-balance scale and a piece of non-conducting cord. Both of these equipments as used are shown in the two accompanying drawings.

The method of procedure after removing the magnet from the magneto is first to test its strength. This is accomplished as shown in Fig. 2. The block of wood is held in a vertical position in the jaws of a vise or other handy object and a rod with a hook at its end is slipped into a staple and plate screwed to the top of the block of wood. A spring-balance scale with a ring at the top is suspended from the rod, the magnet being hung from the scale by a strong cord but with the two ends touching a clean flat iron-plate laid on the bench beside the vise. On account of the magnetism remaining in it when removed, the magnet will tend to adhere to the flat iron-plate; it can be pulled away by pushing up on the rod, at the same time registering the pull on the spring-scale. After this has been done several times and the pull registered each time, calculate the average pull to release the magnet and the area in contact with the flat iron-plate. If the pull required is less than 30 lb. per square inch, the magnet is weak and should be remagnetized as shown in Fig. 1.

The 100 ft. of wire should be formed into two equal coils into which the legs of the magnet can be inserted. The polarity of the coils should be tested by means of the pocket needle compass and the current from one of the dry cells, the needle being attracted by one coil and repelled by the other. Then test the magnet itself by means of the compass and place the positive magnet leg in the positive coil and the

negative leg in the negative coils. This is of great importance; for if the positive leg is inserted in the negative coil, the polarity of the magnet will be reversed and it will become useless. Next wire up the end of the coils with the three cells as shown, with a break in the circuit. The magnet is remagnetized by alternately bringing together the ends of the wire at the circuit break and then pulling them apart. This operation should be continued for about five minutes, after which the magnet should be tested as described above. If the magnet does not show enough strength the first time, the remagnetizing process should be repeated until it does. This

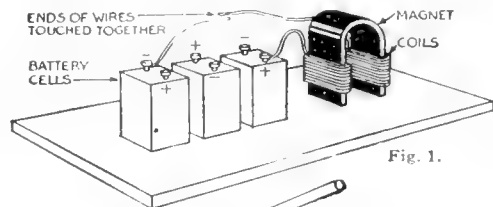

Fig. 1.

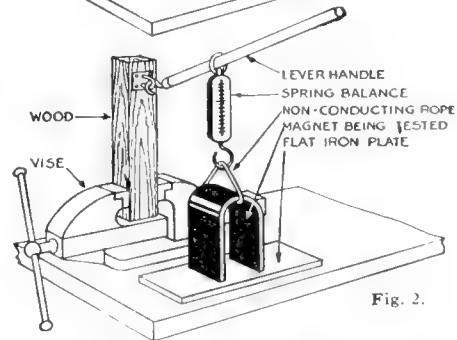

Fig. 2.

Fig. 1. Method of remagnetizing magnets  
Fig. 2. Calculating the strength of the magnet

accomplished, an iron keeper should be placed across the magnet legs so that its strength will not be dissipated through the tendency of the magnetism to jump the air gap between the poles if left free.—JOSEPH BRINKER.

### The Telephone Receiver for Wireless Apparatus

THE telephone receiver used in wireless telegraphy is a very sensitive instrument, and gives signals from exceedingly small amounts of electrical power passed through its magnet windings. Nevertheless, measurements have shown that only about one one-hundredth of the power applied electrically is actually converted into sound-waves.

### The Construction of a Small Concrete Corn-Crib

THE roof of this corn-crib is made of lumber and the side walls and floor are of concrete. The walls consist of concrete fence posts—the ordinary kind with 3-in. tops and 6-in. bases. The foundation and floor of the building are of concrete mixed in the proportions of 1 part cement, 3 parts of sand and 5 parts gravel or stone broken in pieces not larger than 2 in. in any dimension. It is a permanent crib, reasonable in price.

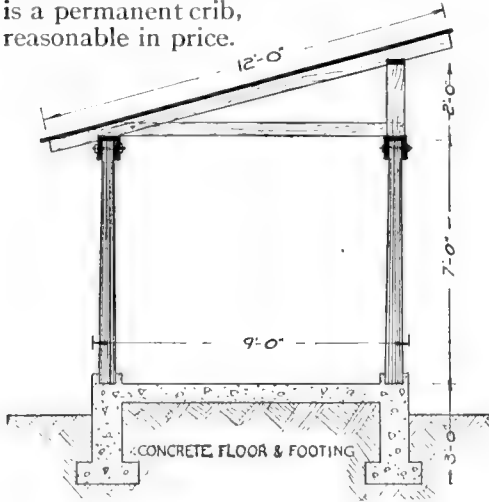

Corn-crib made with concrete posts for the side walls and with solid concrete floor

The posts are anchored at the bottom to the concrete and at the top are securely clamped together with a box-plate made of three 2 by 6-in. pieces bolted together every 4 ft. over the top of the posts. Along the front side of the crib there is a short studding about 2 ft. long which supports the roof and makes a convenient place where the grain may be thrown in the crib. The rafters are spiked to the plates and are set on 2-ft. centers. Across the top of the posts from plate to plate a cross-tie is run from each rafter. This makes the crib solid and will prevent the sides from spreading.

In the center of the crib criss-cross braces of wire should be put in, twisted taut and fastened to bolts at the foundation line.

Cover the roof with shiplap for sheathing, making a tight and smooth foundation for the three-ply asphalt-and-felt prepared roofing material which is laid lengthwise of the building.

The posts should be of a 1-to-3 mixture of cement and sand made into a sloppy consistency before pouring it into the forms. One sack of cement will make about 8 posts, weighing 90 lbs. each. There should be three  $\frac{1}{4}$ -in. round steel rods placed in the center of each post to reinforce it. For an 800-bushel crib of a size 9 ft. by 32 ft. the following amounts of materials will be required:

- 13 barrels cement for floor and foundations
- 6 cubic yards of clear sand
- 10 cubic yards of coarse gravel
- 80 concrete posts
- 2 dozen bolts  $\frac{5}{8}$  by 8 in.
- 300 ft. of 2 by 6 in. material for box-plates 16 ft. long
- 100 ft. of 2 by 4 in. material for cross-ties 9 ft. long
- 150 ft. of 2 by 4 in. material for rafters 12 ft. long
- 40 ft. of 2 by 6 in. material for studding 2 ft. long
- 450 ft. of shiplap sheathing lumber
- 4 squares of three-ply roofing felt.

### Experiments with Antennas of Varying Lengths

AT some wireless stations very interesting results have been secured by providing a number of single-wire aerials of various lengths and extending them in different directions from the operating room. By the use of single-pole, double-throw switches these may be connected to the receiving tuner or directly to the ground, or left open-circuited. Various combinations are found to give good results in receiving from particular stations, depending upon the direction and wavelength of transmission.

It has sometimes been found valuable to ground one wire through tuning inductance while receiving on an entirely separate aerial.

---

Those of us interested in science, engineering, invention form a kind of guild. We should help one another. The editor of *THE POPULAR SCIENCE MONTHLY* is willing to answer questions.

# *A Big Christmas Present For Only \$1.50*

This year give your friends a real present, one they will enjoy through the whole year. Give the Popular Science Monthly for 1917. A year's subscription, twelve months, costs only \$1.50. The twelve numbers will contain

over 4,000 pictures

over 2,000 articles

over 1,800 pages

and will tell the whole wonderful story of the year's progress in invention, mechanics, and science.

A Christmas Gift Card will be sent to each friend announcing your gift. The first copy of the magazine and the Gift Card will be received just before Christmas.

Send your list of gift subscribers as soon as possible, and surely before December 15th.

Subscription \$1.50. Canadian postage 50c extra. Foreign \$1.00 extra.

**Popular Science Monthly Gift Club**  
239 Fourth Ave., New York, N. Y.

# A Detachable Conning Tower Lessens Submarine Risks

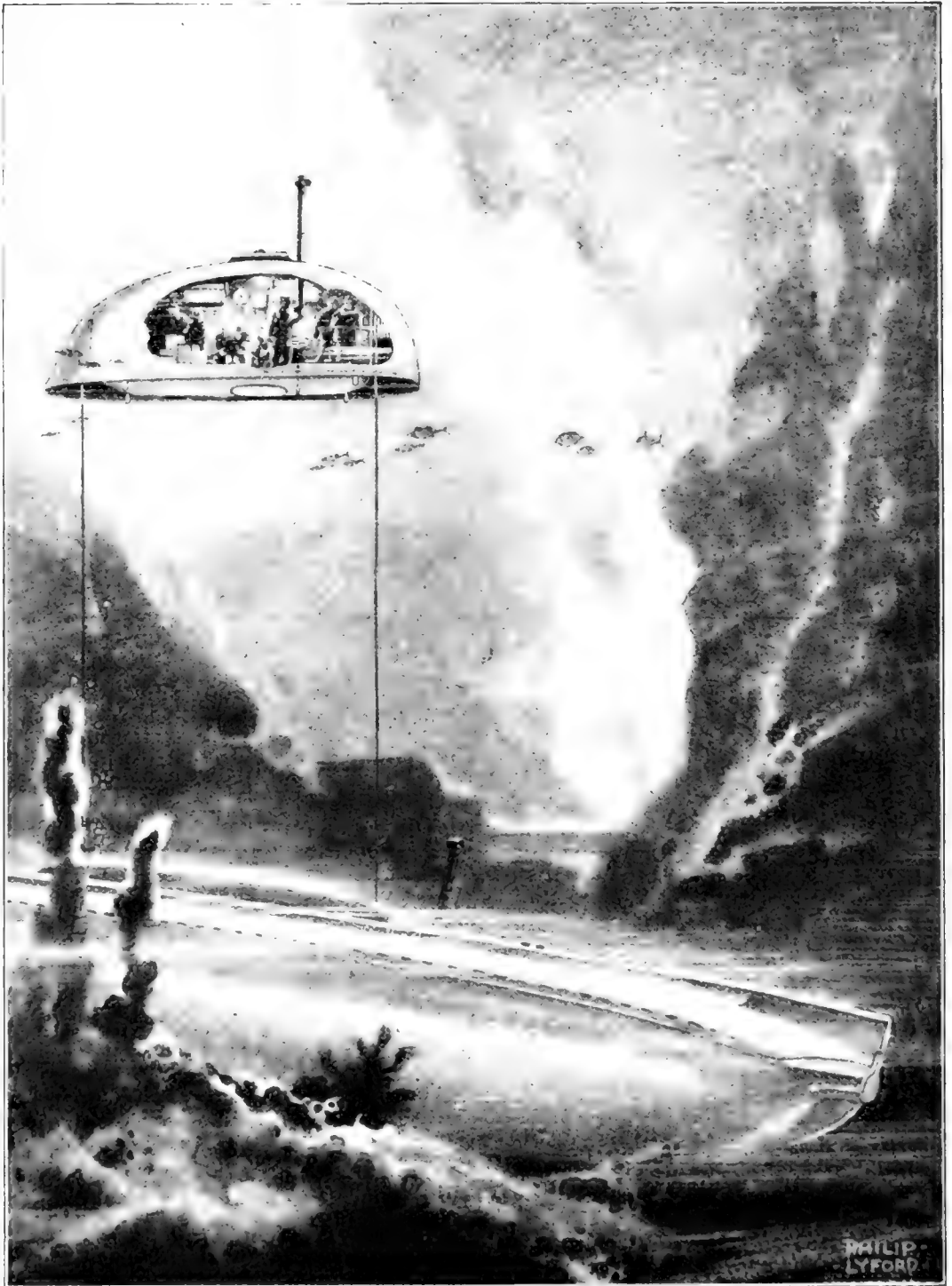

The entire crew get into the conning tower, detach it from the body of the submarine, and regulate by the windlasses, the speed of the ascent of the tower as its buoyancy raises it to the surface where it signals for help. The body of the submarine can be recovered by means of the cables

# Popular Science Monthly

239 Fourth Avenue, New York City

Vol. 89  
No. 6

December, 1916

\$1.50  
Annually

## Saving Men from Sunken Submarines

Three means by which the crew of a sunken submarine may finally escape

By Lloyd M. Kuh

**T**WELVE-THIRTY o'clock. Respiration is extraordinarily difficult. I mean I am breathing gasoline.

"It is 12:40 o'clock."

Such were the last words of the commander of the Japanese "6", written while imprisoned in the conning-tower of his submarine at the bottom of the sea. This was some six years ago, when he and thirteen of his crew met with an accident and died a slow and painful death, simply because the submarine was not provided with a suitable means of escape.

Even before this time, one hundred and twenty-four men had been lost on that account; and as many have been lost since then—all in times of peace. But the fault was nobody's; for no rescuing devices had been invented which could have been depended upon and which at the same time did not take up too much of the all-too-precious space.

And we are still experimenting on devices for saving men from sunken submarines. A great many schemes have been invented, a few of which at least indicate that we are on the right track. These few divide themselves into three classes.

In the first class are those devices which have a buoyant detachable conning-tower. This tower contains all the appliances of an ordinary conning-tower; but such things as the steering-rod must be made in two

parts which can be separated when the tower is disconnected from the body of the submarine. A windlass is mounted at each end of the tower and upon each a cable is wound. The other ends of the cables are fastened to the body of the submarine. Four large bolts hold the tower to the submarine's body.

Should anything go wrong, all the men can climb into the tower, close the hatch behind them, turn on the oxygen from the tanks, unscrew the bolts and rise to the surface. By means of the handles of the windlasses, the speed of the tower can be controlled as it rises. When they reach the surface, they can open the windows and send out signals of distress by an electric flashlight.

This plan will work should the submarine sink as far as three hundred feet. Below this depth no scheme will be of use, for the water pressure is so enormous that it will

actually force the water right through the pores of the steel hull. This "sweating"—as an engineer would call it—would soon weaken the rivets and finally result in crushing the submarine like an egg-shell!

An entirely different invention has two compartments within the submarine, from which the crew can escape through hatches to the top of the boat. To open the hatches, it is necessary to let water into the compartments through a valve, until the

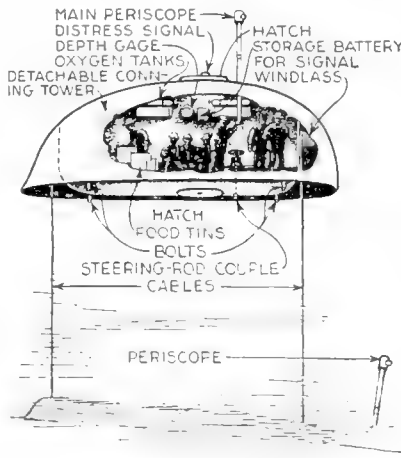

Detail of the conning-tower which is released from the submarine



compartments are completely filled. In this way the great pressure of the water on top of the hatches is relieved.

In an emergency, the crew immediately put on light diving-suits. These contain oxygen apparatus which not only prevent suffocation, but also prevent the water from crushing the body. Three or four men enter each compartment and shut the water-tight door behind them. Letting in the water, they open the hatch and climb out. After they have emerged, the hatch is closed by gears connected to it in the inside of the submarine. The water in the compartment is then ejected into the ocean through drain-pipes connected with a hydraulic hand-pump which the imprisoned men operate. Then three or four more of them may enter the compartment and escape in the same way.

After all the crew reach the top of the boat they release a buoy which moves upward towards the surface cable with it. Up this the men must climb.

It seems strange that they must climb out and are not forced upwards as soon as they touch the water. The reason for this is that the weight of the suits is so great that, peculiarly enough, it tends to keep the men at whatever level they happen to be.

Due to the fact that the men have to expose themselves to the pressure of the water, this plan cannot be used at a greater depth than 225 feet. Even at this depth, the pressure is 8½ tons per square foot. Divers have gone down this far; but one, who went down 288 feet, at the time of the F-4 disaster, permanently injured his lungs.

The manner in which the oxygen is supplied from these suits is extremely interesting. A small cylinder strapped to the back of the wearer contains the oxygen, which is stored at an enormous pressure of one hundred and fifty tons per square foot. The oxygen is slowly released from this by an automatic ejector which regulates its pressure as it is supplied to the body so that it nearly equals that caused by the ocean outside. After the oxygen has been

consumed, it is thrown off by the lungs as carbon dioxide, and this the lungs force into a cartridge of chemicals where it is completely absorbed. After this absorption, only the nitrogen of the air remains, but this is again passed over the ejector and mixed with fresh oxygen before it enters the lungs once more. In this way the same nitrogen is used over and over again.

In a third class of devices, the men do not leave the submarine at all. Two buoys are fitted in the superstructure at both ends of the submarine. Attached to each are a cable and two flexible hose, while directly under the point where each buoy is held on the submarine is a compartment into which the crew get in time of danger. Then the buoys are released. As they rise, they carry the cables and hose

with them. An unlimited amount of fresh air can now be had by working air-

pumps which are connected to the lower ends of the hose. In the two compartments, the men must stay imprisoned until a salvage vessel answers their distress signals, given out by an electrical flashlight within the buoys.

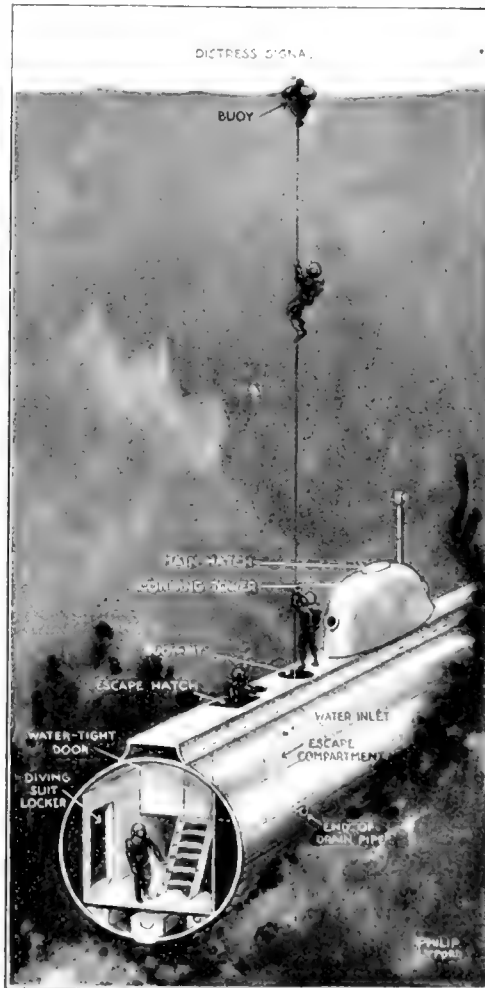

In an emergency in this submarine, the crew put on light diving jackets, escape to the top of the boat through the compartments and hatches, and climb to the surface on the cable attached to a buoy

# Signaling for Help with Flashlight Buoys

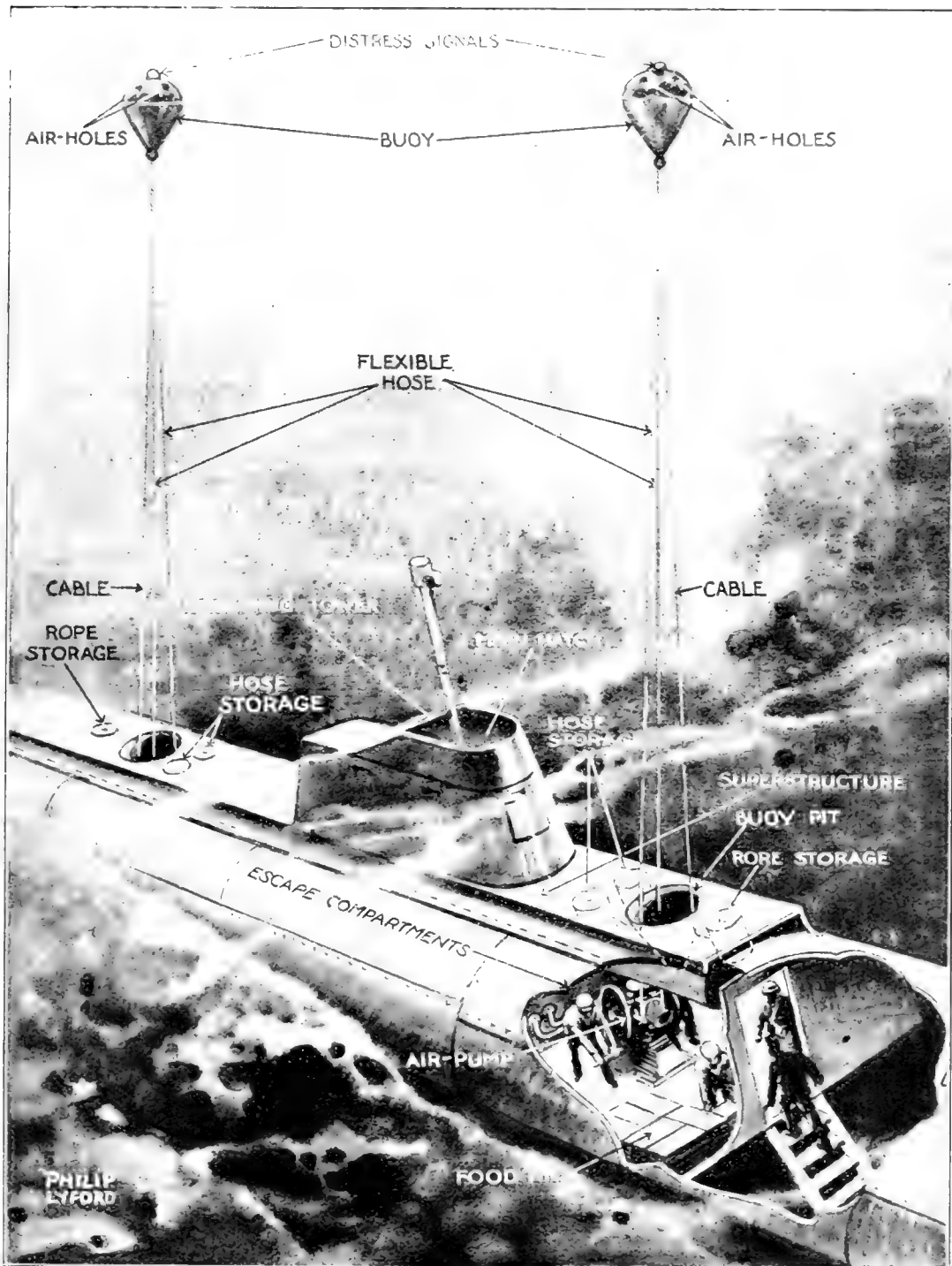

The crew get into the compartments and release the buoys. Until their distress signals are answered, they receive a supply of fresh air through the hose attached to the buoys. On the arrival of a salvaging ship, the submarine is hauled up by means of the cables and the men are freed

### Timing Automobile Speed Demons with a New Device



The end operators are equipped with push-buttons and telephones connecting with the stop-watches at the central station. A third man flags the offender with an illuminated signal

**I**F THE invention of E. H. Pendleton is widely introduced, automobile drivers may no longer break the speed laws and escape punishment through lack of evidence. Pendleton's device consists of a neat wooden box containing a telephone, two push-buttons, and two stop-watches, regulated to the tick of a second. The three men required to operate it are located along a given road at points six hundred and sixty feet apart. An operator is stationed at the central point with the instrument. End operators have telephonic communication with this central station, and are also equipped with push-buttons connected by electric wires with the stop-watches at the central station.

When an automobilist who is going faster than the law allows, approaches from either end, the operator presses the push-button, and the stop-watches six hundred and sixty feet away are set in motion.

When the automobilist reaches the point where the watches are located, the operator there instantly stops the watches, thus registering the

time. If the speed limit has been exceeded, the central operator, by means of the telephone, orders the third man to arrest the speeder. This he does by displaying a red lantern and illuminated sign, reading "Police." As a rule, the motorist has no idea that he is being timed until he is "flagged" and arrested.

A number of cities on the Pacific Coast have adopted the system, one of which in one day collected fines amounting to over half the purchase price of the system.

### Novel Method of Drive for Light Cycle-Cars

**D**RIVING through the peripheries of the rear wheels and steering through pivoted axles, the novel method of combined driving and steering shown in the accompanying sketch should prove of value to the designers of light cycle-cars and the like. The driving is accomplished by the friction between the rear wheels and metal drums on the opposite ends of the motor crankshaft, which is carried crosswise of the vehicle frame. The steering is done through the use of pivoted axles front and rear, the opposite ends of which are connected by two cross wires manipulated by means of a crankshaft and arms fastened to the vehicle frame.

In turning corners, the friction drum on the outside of the curve is released from its contact with the rear tire, while that on the inside of the curve presses with greater force against its tire. Brake action is secured by constructing each of the metal friction drums of two telescoping parts with coned surfaces.

The outer part of the drum, which is cylindrical on the outside where it comes into steady contact with the tire, is forced in or out of the clutch-action by means of a fork.

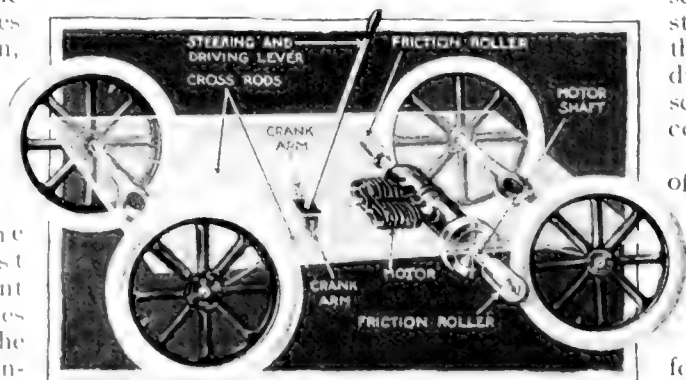

The driving is accomplished by the friction between the rear wheels and the metal drums of the motor crankshaft, which is carried crosswise of the frame

# Wigwagging with Hand Flags

How the army talks over hills and valleys

**A**LTHOUGH their application is limited on account of their small range, the use of hand flags for signaling is authorized by the United States Army. They are chiefly serviceable for incidental signaling or for use within organizations or fixed stations. The range is seldom more than a mile with the naked eye with flags of usual size, and is dependent upon light and background. But the system is simple and rapid and should be familiar to all soldiers. It is limited to visual signaling and is not adapted to general work as is the General Service Code, although it has been found very useful for special work when rapid communication at short distances is necessary.

The semaphore hand flags for service use are eighteen inches square, divided diagonally into two parts, one red, the other white. The staffs are twenty-four inches long. For the field and coast artillery there is now issued a semaphore hand flag of orange with a scarlet center and scarlet with an orange center, one of each constituting a kit. The flags are eighteen inches square, the centers nine inches square and the staffs twenty-four inches long.

Hand flags are used in the same manner as the semaphore machine, except that in making the interval the flags are crossed downward in front of the body, just above the knees. This method of signaling is used to advantage within batteries of the field artillery and regiments of infantry



ATTENTION



NUMERALS FOLLOW



INTERVAL

Care must be taken with hand flags to hold the staffs so as to form a prolongation of the arms. With the two-arm semaphore both arms move simultaneously, and there is a pause at the end of each letter

and at times is used by the cavalry. It has been highly developed in the Navy. The hand flags of the Navy are from twelve to fifteen inches square, of blue with a white square, or red and yellow diagonally, the colors depending upon the background. The flags are usually attached to a light wooden staff about two feet long.

Signaling by two-arm semaphore in the Navy is very similar to hand-flag wigwagging. The ordinary machine or stationary semaphore is also authorized for general use by the Army at the present time. With the machine a third arm or indicator is displayed on the right of the sender, which is the left as viewed by the receiver. At night a red light screened to the rear indicates the direction of sending.

The machine is mounted at some available point so situated that it may be seen through the greatest arc of the horizon. By means of electric lights installed on the vanes, the machine is made available for night as well as for day signaling. This method is the most rapid for sending spelled-out messages. It is, however, very liable to error if the motions are slurred over or run together in an attempt to make speed. Both arms move rapidly and simultaneously, and there is a perceptible pause at the end of each letter before making the next letter. When communicating with the Navy numerals are always spelled out. In using the machine signal, men are taught that rapidity is secondary to accuracy.

# Conventional Signals Used in the Army and

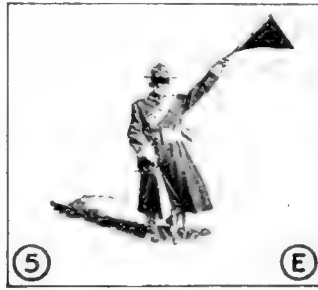
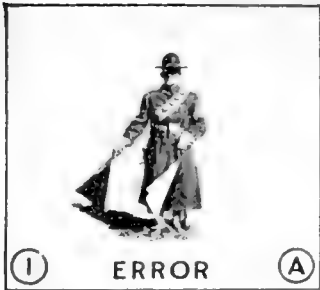

To call or answer: "Attention" followed by call letter of station called. Repeat as necessary. Both stations then make "Interval"

Repeat last word: CC "Interval" twice

Repeat last message: CCC "Interval" three times

Repeat after (word): CC "Interval" A (word)

End of word: "Interval"

End of sentence: "Chop-chop" signal. To make this, both arms are placed at the right horizontal and then moved up and down in a cutting motion

End of message: Two successive "chop-chop" signals and withdrawing the flags from view

Error: AA—"Interval," then repeat word

To break in: "Attention"

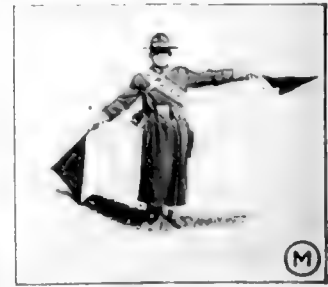
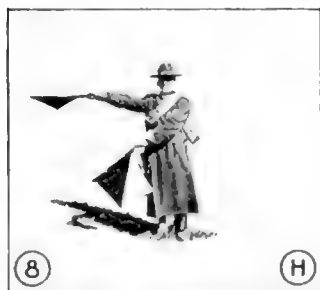

# Instructions for Wigwagging with Flags

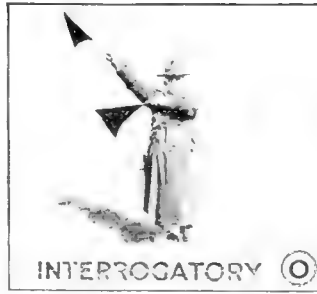

"Negative," "Affirmative," or "Interrogatory" followed by "Interval" give corresponding meanings to the following signal

Receiver acknowledges "Attention" whenever made, also "Repeat," etc., and end of message when latter is understood

While waiting for "Acknowledgment," or in case of delay remain at "Interval"

Words not in code are spelled out

"Numerals" precede every number sent and indicates numerals until "Interval" is made, after which letters recur without any further indication. When numerals follow letters no intervening "Interval" is necessary. The numerals are the first ten letters in order. When communicating with the Navy numerals are spelled out



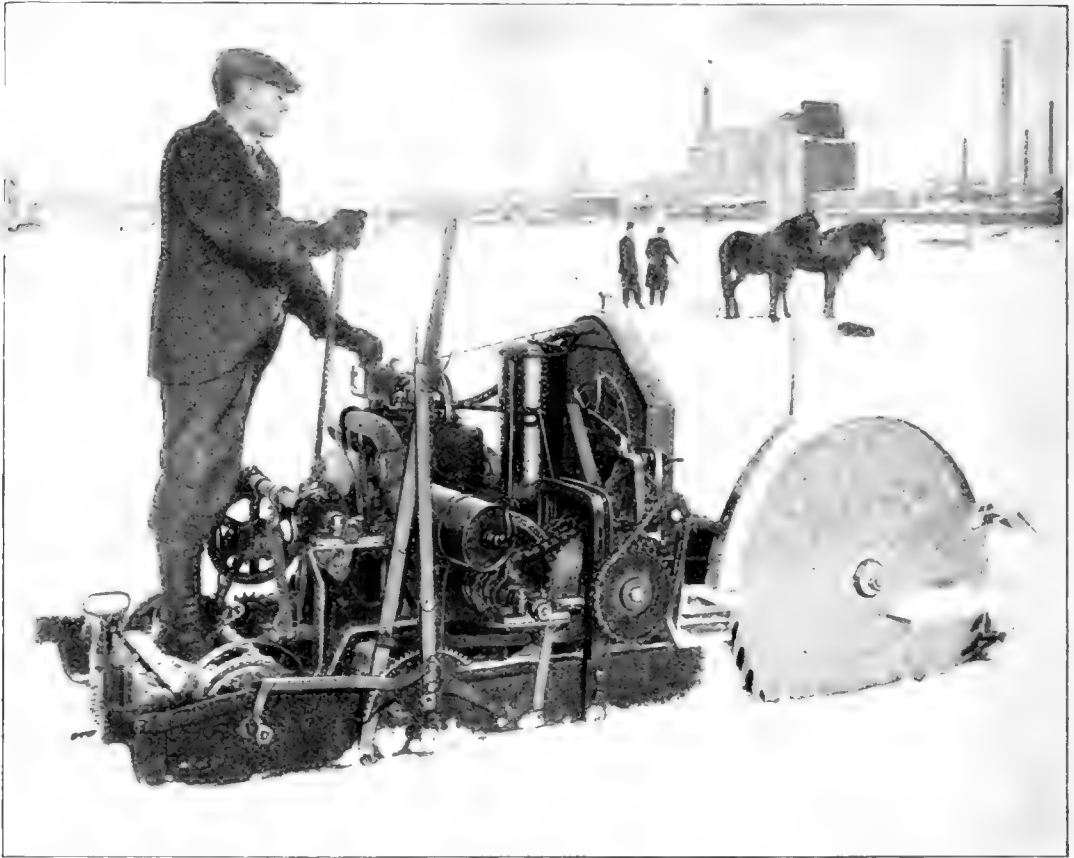

The saw is geared directly to the motor and works in either direction. It will cut thirty thousand cakes of ice per day, thus equaling the work of sixteen men with eight horse-teams

### This Ice-Cutting Machine Takes the Place of Eight Horse-Teams

**E**QUIPPED with a thirty-five horse-power gasoline motor, which both drives the machine and operates the cutting saw, a new type of ice-sawing machine has been put on the market by a western manufacturer. It will cut one cake of ice a second, or thirty thousand cakes a day, thus equaling the output of sixteen men and eight horse-teams.

The machine is one of the few gasoline ice-sawing machines in the field at the present time, which can be run in either direction with equal success. Spiked wheels driven by gears and chains from the motor move the machine over the ice, and the single large ice-saw may be raised or lowered to cut to a depth of from six to sixteen inches according to the thickness of the ice. The speed of the apparatus is regulated by means of a friction disk similar to that used on some automobiles. The saw is geared directly to the motor and cuts in either direction. Since the machine

can cut in either direction, it is not necessary to turn it around at the end of a cut, but merely to shift it back.

### Taking Care of Automobile Tires at the Front

**I**N THE early days of the war the wastage of automobile tires in France was alarming. The suddenness and the extent of the effort necessary to stem the tide of invasion put economy out of the question. Tires were abandoned as soon as they were damaged and claims for new ones were never questioned. The drivers had neither time nor tools for making repairs, in most cases. But now each driver works from a base or depot, to which the worn or damaged tubes and casings must be returned. From the depot the damaged tires are sent to central repair stations where they are repaired, tested, dried, talced and packed in cardboard boxes marked with all necessary descriptive data. These repaired goods are stored in special storehouses and distributed as needed.



**A Wonderful New Glass Which Cannot Be Shattered**

**A** NEW glass, transparent, tough and strong, which has all the advantages and none of the defects of brittle, fragile window glass, has been invented by Frank Shuman, of Philadelphia, whose earlier inventions include wire glass, a widely used form of concrete piling, and the sun power plant erected at Maadi, near Cairo, Egypt.

A two-caliber bullet cannot penetrate the new glass; a brick cannot shatter it; a heavy man thrown against it under all the terrific momentum of a collision would not go through it, but would be thrown back from it, uninjured by flying

glass, because none would fly. A stone thrown against it will bounce back like a golf ball.

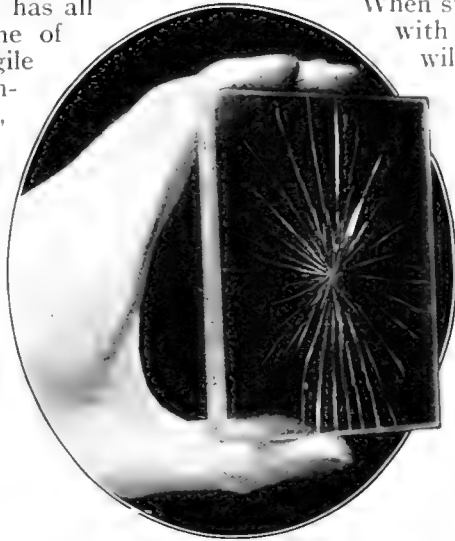

A sharp blow with a hammer may crack the glass but will not shatter it into splinters

When struck a powerful blow, as with a hammer, for instance, it will crack into hair lines, as shown in the accompanying illustration, but there will be no shower of flying glass or splinters. Furthermore, these hair-line cracks leave the surface absolutely smooth.

The secret of its strength is a sheet of white, transparent celluloid, twenty-one thousandths of an inch thick, which is placed between two pieces of glass. The glass and celluloid are simply welded together under high temperature and tremendous pressure, the resultant being a solid sheet possessing all the transparency of the best plate glass, combined with the strength of a sheet of metal.

**Preventing Boiler Troubles by Mechanical Cleaning**

**T**HE shortcomings and difficulties connected with the hand-cleaning of modern steam-boilers have resulted in the development of the mechanical steam-blower, the latest and most effective type of which is shown in the illustration. It employs nozzles arranged across the width of the boiler, so that all surfaces are equally accessible and soot cannot be blown from one part of the boiler to another.

Two cleaner-elements are mounted on bearings and rotated by a chain and sprocket-wheel outside the setting. The jets of steam are directed along diagonal paths, one in one direction and the other in the opposite direction. When they are discharged into the passages between the tubes, the cleaner is slowly rotated, back and forth over a wide arc.

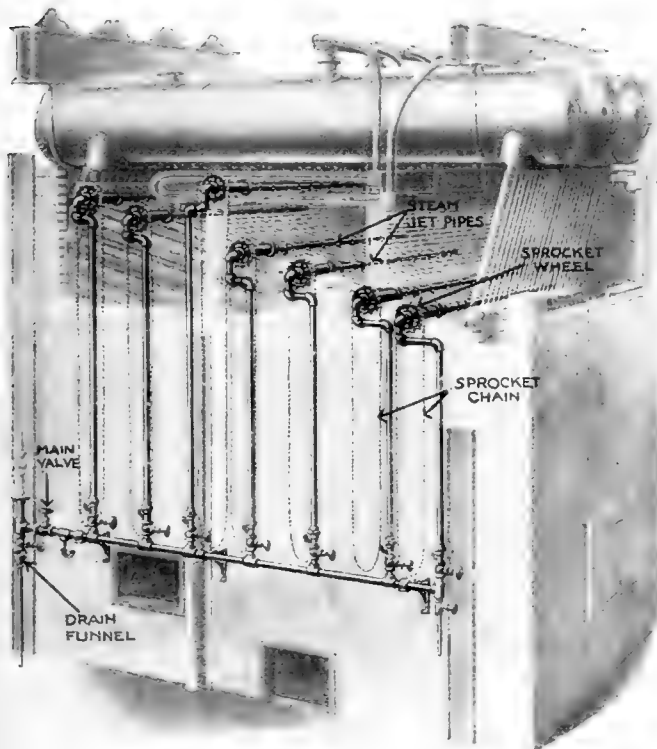

A boiler can be blown clean in six minutes. If cleaned once in every six hours it will increase five per cent in efficiency

# Why Do We Grow Bald?

Disease and tight hats are not the chief causes.  
Baldness can be inherited, like other traits

By D. Osborn, Ohio State University

IT IS popularly supposed that some forms of baldness are caused by the wearing of tight hats. Often the line of baldness seems to coincide with the hat-band, which might show that it is cutting off the supply of nourishment to the scalp. One of the main arguments in support of this theory is that women do not become bald.

In making a study to determine whether heredity is an important factor, I considered only pattern baldness. By pattern baldness is meant the kind associated with thin, normal or heavy hair. It usually does not put in its appearance until after the twentieth year. Among the various patterns the most common are complete baldness on the top of the head; that involving only the crown; that giving the appearance of an extremely high forehead, and that covering the top and back portions of the head.

In one family the father was bald before he was thirty. His only son showed the same baldness pattern at birth, but later grew a normal head of hair, which he retained until the past year. Now at twenty years of age the hair is beginning to fall out in the same fashion that his father's did. This indicates that the baldness pattern may be plainly defined at birth.

In two families which were studied, no baldness whatever could be

found. Heavy hair predominated and was retained to an advanced age. Tight hats were worn by the men, but neither the hats nor severe illness had affected the luxuriance of the hair.

The families which were traced in reference to baldness show clearly that it is inherited. Contrary to the prevalent belief, women do become bald. They are more sensitive concerning it, and can more easily conceal it than men. However, there are fewer bald women than bald men, due to the method of inheritance. Pattern baldness is called a "sex-limited trait." The characteristic is transmitted directly from father to son and may be inherited through the mother, though she herself is not bald. A bald man may transmit the trait to his daughter, who though she does not show it herself

can transmit it to her children. A woman of this type is called a carrier. If a woman inherits the tendency to baldness from both parents she herself becomes bald. Inheriting the tendency from both parents does not necessarily mean that both parents must be bald, but that the father is bald and the mother a carrier. A bald woman must inherit double the tendency that a bald man inherits.

That women may behave as carriers of baldness explains why it may skip generations and ap-



Obviously the line of baldness here does not coincide with the hat-band



The man on the right is thirty-five years old. The one on left is fifty. The patterns of baldness are distinctly different

pear in a family suddenly. The carrier tendency can be transmitted from mother to daughter so that baldness itself might not show for many generations. In the long run half the sons of a bald man or a woman carrier will be bald and half of the daughters carriers. If the mother is bald all of the sons will be

bald and all of the daughters carriers. Illness will occasionally cause baldness in women when there is only the single inherited tendency. In a case of this kind not all of the sons will be bald. Where there is no tendency to baldness the hair may fall out from poor health, but afterward it is regained.



Father and daughter aged sixty and twenty-two. Both have luxuriant hair, although the father lost his in youth through fever

### A Bicycle Which Won't Let You Lose Your Balance

**A**N APPARATUS has been invented by Eugene Tourtier, of Paris, France, which gives bicycles, motorcycles and every other similar vehicle a vertical equilibration regardless of whether or not the road is level. It is merely necessary to support the machine in an upright position by operating a lever attached to the handlebar.

The lever can be operated while the bicycle is moving, making it possible for a rider to remain in his seat as the wheel comes to a stop and to start again without dismounting.

The apparatus consists of two steel-rod supports pivotally attached to the rear frame of a bicycle or motorcycle, and a strong, flexible wire which leads from the supports to the lever on the handlebar. The supports may be forced downward as the bicycle moves, causing it to stop quickly and holding it upright and steady when it does stop.



The steel rod supports are strong enough to sustain a combined weight of eight hundred pounds

### Cork Fabric for Featherweight Raincoats

**C**ORK fabric is a recent French production, the result of a new French process. It is waterproof, a non-conductor of heat, and unbreakable. By using a special machine, thin slices of cork of an even thickness are obtained from a block of cork. The slices are placed in chemical baths in order to remove the resinous parts which make cork a more or less brittle substance. Upon their removal the cork sheets become flexible and may be compared in this respect with thin leather. In fact, the sheets can be folded and bent without breaking.

By combining the cork sheets with any suitable cloth, preferably a thin and strong cloth of good color, an excellent waterproof material is obtained. An adhesive preparation is employed to glue the cork to the cloth; or, if a stronger garment is desired, the cork sheets are placed between two layers of cloth. The cork fabric has a decided advantage over ordinary rainproof materials because it is porous, permitting ventilation where the ordinary raincoat prevents it. Of course the cork is very light. A coat made of it is said to be the lightest on the market.

Of course the cork is very light. A coat made of it is said to be the lightest on the market.



Yakutat Indians in native costume for Potlatch Festival. Their entire season's earnings of \$4,800 at the canneries were spent in two days of riotous celebrating at these festivities

Below: Gulls waiting to feast on salmon and their eggs. The fish swim to the headwaters, lay their eggs, and retire when the water subsides. This leaves the eggs for the gulls



# The World With Sixty Million Salmon Annually

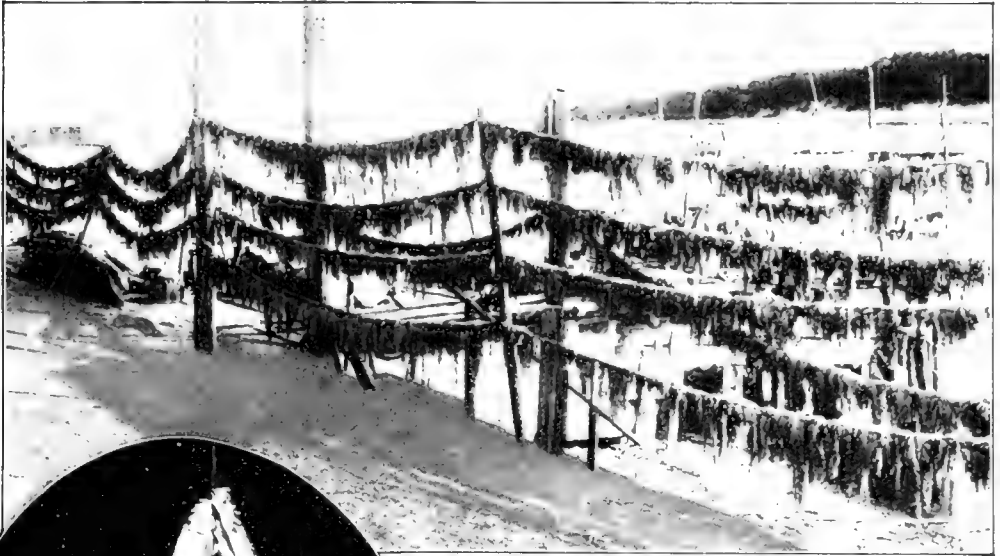

Above: A method used by natives near Sitka, Alaska, for drying herring spawn for fertilizer. This means a partial destruction of the future supply of herring from the Alaskan fisheries. At left: Herring and their spawn. The eggs were deposited on branches that had fallen into the water. The herring industry has yet to be developed to its full capacity in Alaska



A seal rookery on St. Paul Island. There is a possible commercial value in seal meat as food in the United States. The meat is not strongly flavored or in any way unpleasant to the taste. At present it is a wasted product, since only the skin has a market value



## Marooned by the Tide at West Australia

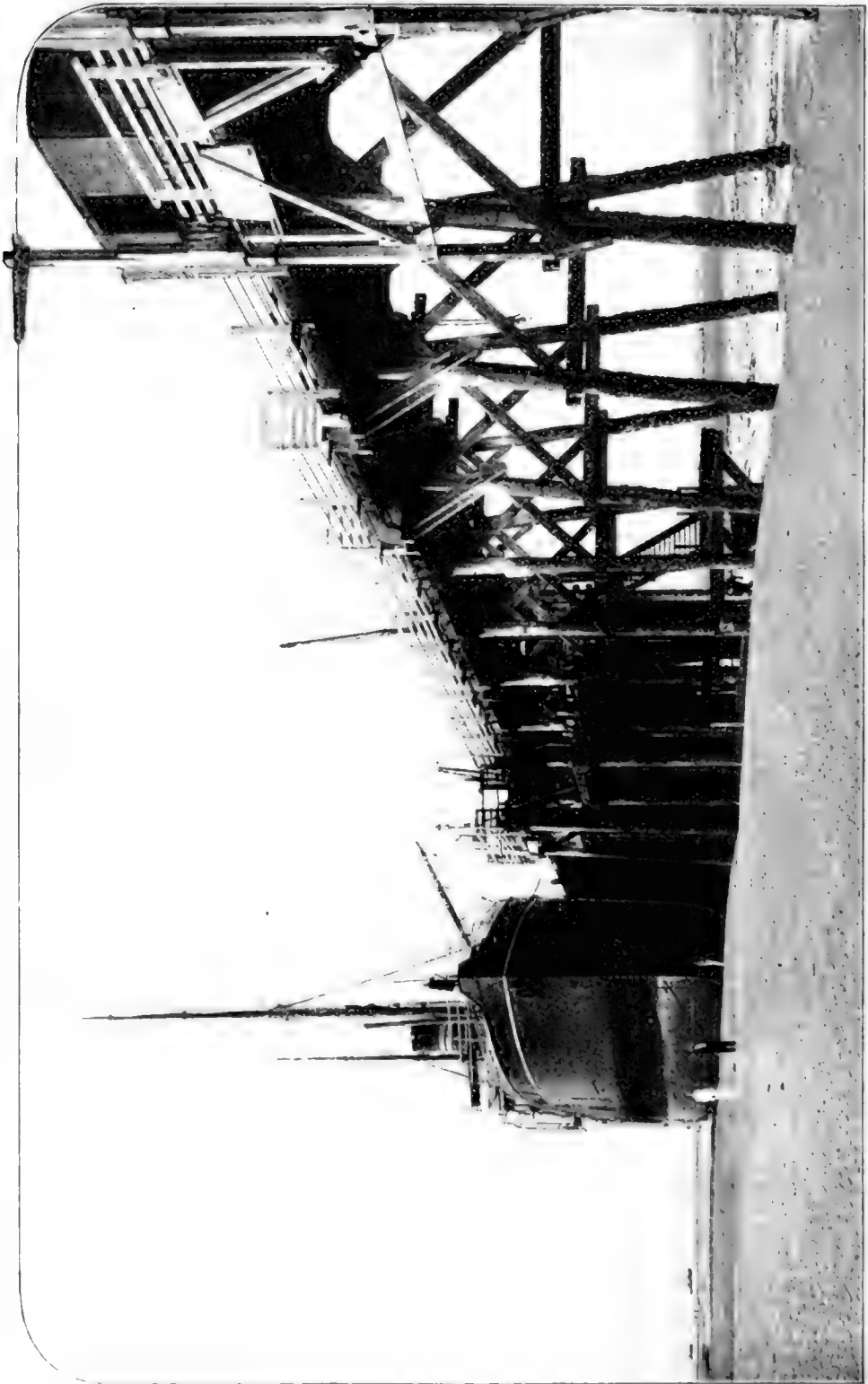

It is not uncommon on the west Australian coast to see several large coasting vessels stranded on the beach adjoining their wharves, waiting for the far-away tide-waters to rush in again before they can put out to sea. The photograph shows a coasting vessel left high and dry at her moorings at Broom, West Australia. In the Bay of Fundy the rushing Spring tides swell to the enormous height of sixty or seventy feet



## Trapshooting in the Navy



Sailors on board the United States battleship "Connecticut" shooting the clay pigeons. The trap used is of the hand-operated variety. The Navy shooters have a registered tournament of their own, for which application was made to the Interstate Association



## New Cures at the Royal Baths in England



Above: The Diathermy treatment for frost-bite. During the past two winters many English soldiers would have lost their feet by amputation except for the timely application of this new treatment which consists in applying electrically heated pads to the feet



At left: The new substitute for mud baths. It is a peat massage bath and is the invention of the general manager of the Royal Baths at Harrowgate. It is believed to be a potent treatment for rheumatism, sciatica, lumbago, neuritis, etc.

# Tropical "Snow Drifts" of Cheesecloth



At first glance these Porto Rican hills appear to be covered with huge snow drifts, but these white areas are tobacco fields over which cheesecloth has been spread to protect the leaves from rain and wind. The cheesecloth can be used only once, after which it is sold as cotton waste

# Here Are a Few Interesting Things to Eat in a

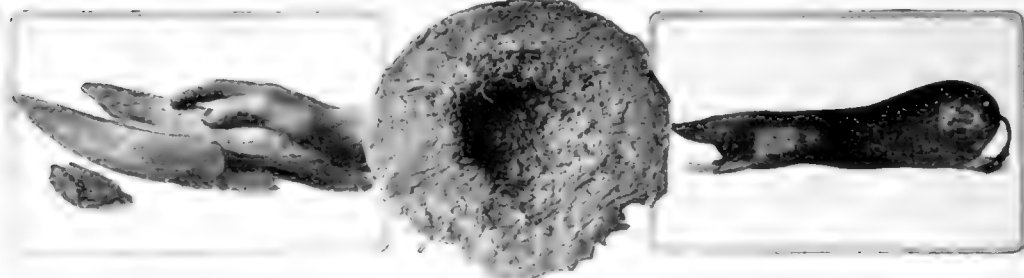

Japanese mackerel steaks smoked and sun-dried to stone-like hardness. When properly prepared they are juicy snacks, so they say. They resemble knife-sharpening bones in this form

Above: A pound of delicately flavored tea packed and compressed by the bare feet of Chinese damsels

Not a toy but an Italian pig's foot stuffed with ham meat. Everything but the tail of cord is eaten. This is but one of many food-freaks that one finds in a visit to sunny Italy

At right: It looks like a football but it's the sun-dried cuttlefish or devil fish of the Greek coast with suckers intact. The shredded part is more tempting than the tentacles



The cuttlefish at the left is of small size. Some are so large that the suckers, when stretched to their full length, can encompass the girth of a half dozen human beings

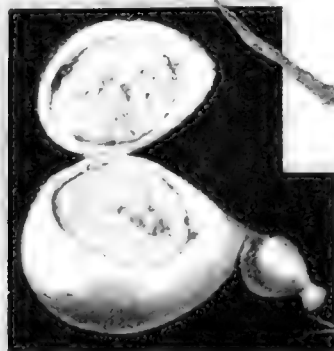

Below: Sun-dried persimmon fruit of the Orient is the size of goose eggs. Both fruit and shell are eaten after they have been boiled

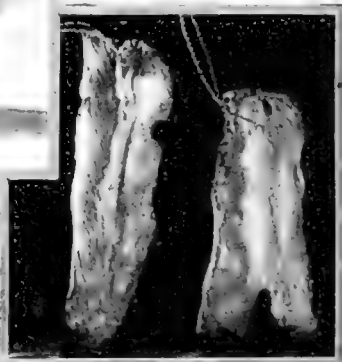

Above: Sweet butter preserved without a particle of salt inside a gourd-like container made of cheese. The whole remains fresh and edible for years



Above: Lean pork strips sun-preserved without salt in Spain. Deer, buffalo, caribou, bear, goat and tuna meat is preserved in much the same way

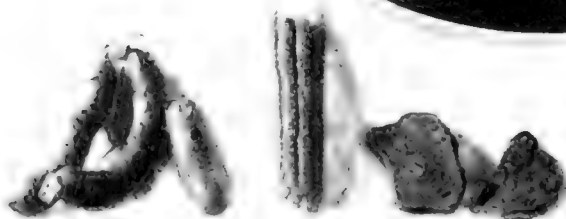

Scotch oat-breadstuff in sausage-link form. Mexican corn and black-brown tortillas. Mexico's famed crystalized cactus-pulp is said to be the choicest table delicacy of the west

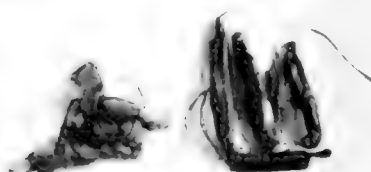

Sun-dried gizzards of Chinese geese. They are of bone-like hardness but are edible when soaked

# Hungry Man's Gastronomic Trip Around the World



Chinese tree-pith breadstuff strips, tamale, and ripened eggs only twenty-five years old

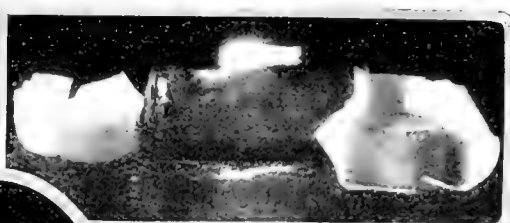

The emergency rations of our soldiers. There are three bread and meat cakes and three pressed chocolate tablets

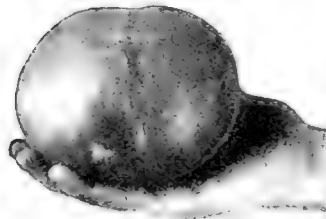

The pure bean cheese of the Orient is made solely from prepared bean-casein curd



Stringed hazel nuts of the Italians. Below: Sun-dried oysters are a delicacy in China

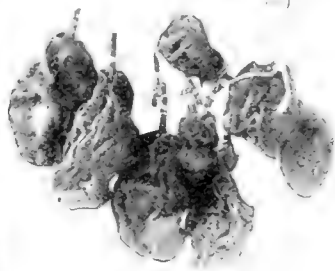

Smoked pears from central European farmhouses are nutritious when properly stewed



Genuine Turkish caviar in its solid roe form. It is clean to handle and keeps for years

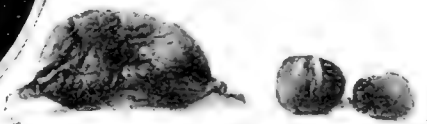

Plum pudding in a bladder container is a great delicacy in southeastern Europe



Cuttlefish preserved in its own ink, the only preserved-in-ink foodstuff known to us



The banana as a dried breadstuff has been used by numerous races for centuries



Chinese-Japanese biscuits made of wheat and bean flour

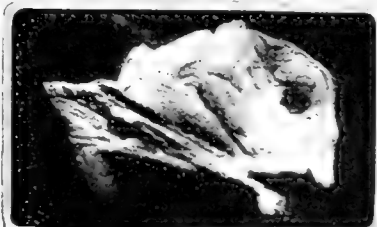

Sun-dried beef of Latin America. Some stretch it for tether ropes

## Queer Denizens of the Deep



Photograph by American Museum of Natural History

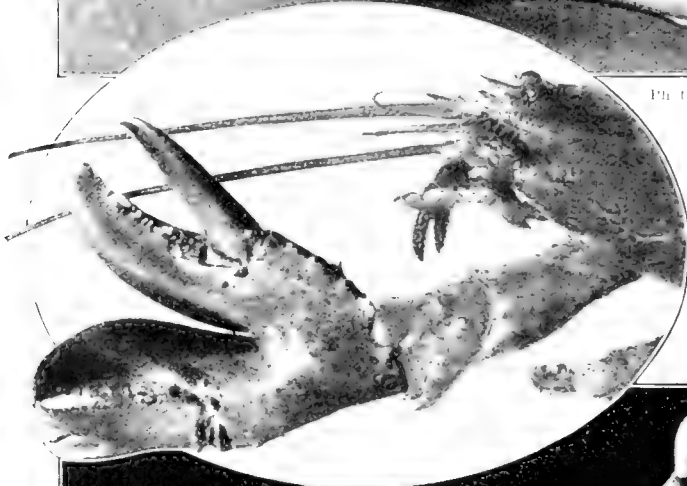

Above: A queer specimen of deep-sea fish which is about twelve inches long and has tentacle eyes each with a phosphorescent bulb attached. At left: A lobster with a double claw. Below is the special kind of louse which torments whales. What would the Popular Science Monthly not give for a picture of a whale scratching himself!

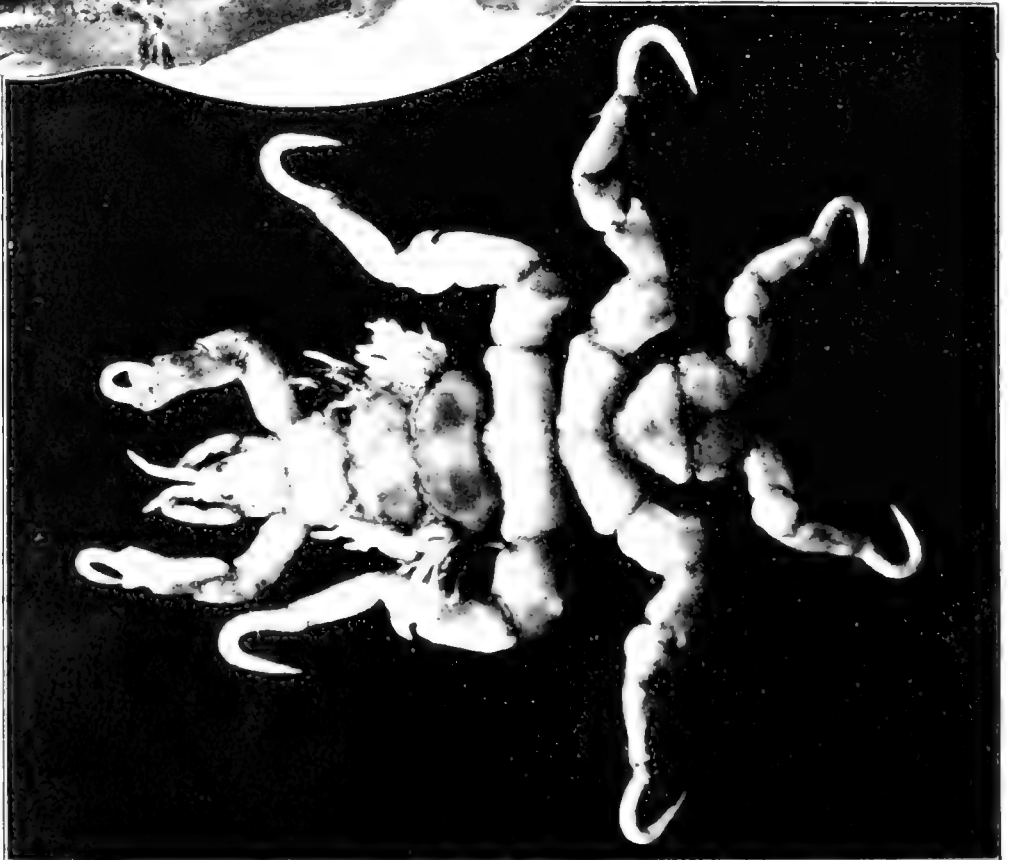

# Is this the Origin of Forcible Feeding?

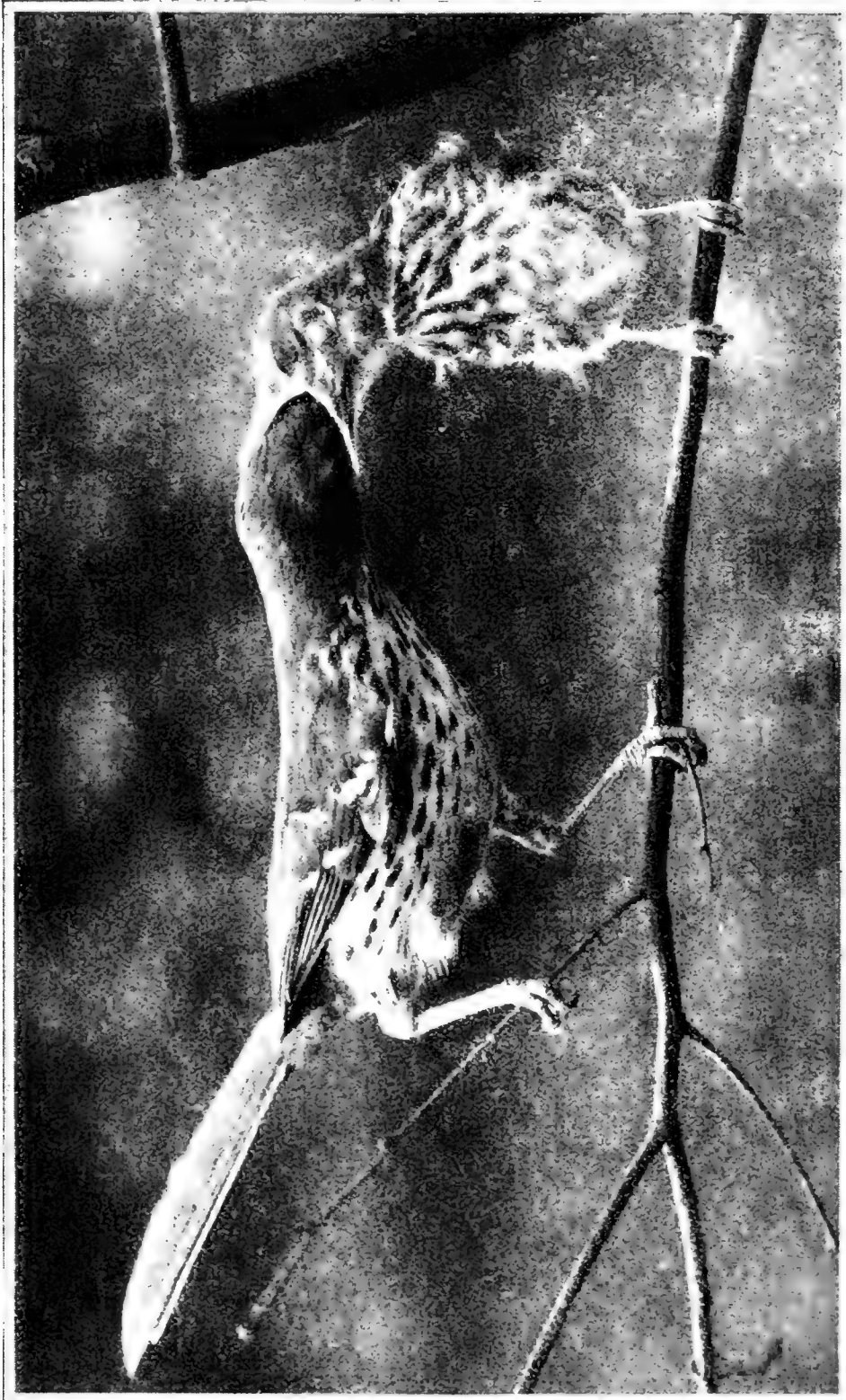

A remarkable photograph of a brown thrasher feeding her young. The mother bird gathers the food, eats and digests it, and then discharges it into the mouth, thrusting it far down the throat of the young bird, whose digestive apparatus has not reached a stage of perfect development.



# The Fighting Weapons of Seven Warring Powers



The German Mauser can fire faster than any other rifle used in the war. The magazine holds five cartridges, packed in chargers

The Austrian rifle is the lightest of all, yet its bullet, 244 grains, is the heaviest used by any of the powers. It is very rapid in action

The British rifle is the outcome of the South African War. It holds ten cartridges and is sighted from 200 to 2,800 yards

The French Lebel is the longest rifle. The tube magazine under the barrel holds eight cartridges. The bullet used in it weighs 198 grains

The Belgian Mauser of 1889 holds five cartridges carried in clips; it cannot be used as a single loader. It weighs over eight pounds

The Russian rifle is 7 in. longer than the British. It is capable of firing 24 bullets to the minute. The bayonet is always fixed

The Italian Mannlicher-Carcano is of the 1891 pattern. It is rather slow, discharging but fifteen rounds of shot a minute



## Aeroplane Art of Today



Above: A Belgian aeroplane decorated with Brownies. This is done not so much for the edification of the enemies as for the personal pleasure that the Belgian airmen derive from it

At right: A grim Medusa's head which acts as a mascot. To imagine this thing coming out of the sky straight at you is to court a week of nightmares. Perhaps this was the purpose of the artist in painting it



# As a Packer Let Us Recommend Mother Nature

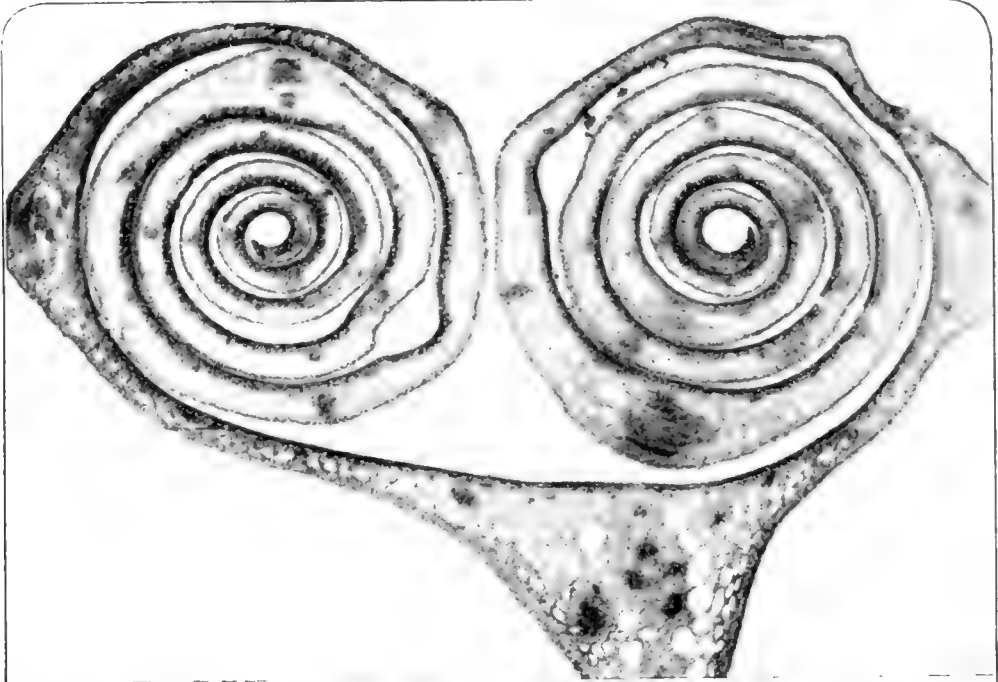

The yellow water-lily bud (above) is about twice the size of a pinhead. The bud of an ordinary sycamore maple (below) is twice the size of the water-lily bud; but the method of protection is entirely different for each. The edges of the undeveloped water-lily leaf are rolled toward the center, while the sycamore maple suggests a handful of squeezed lettuce

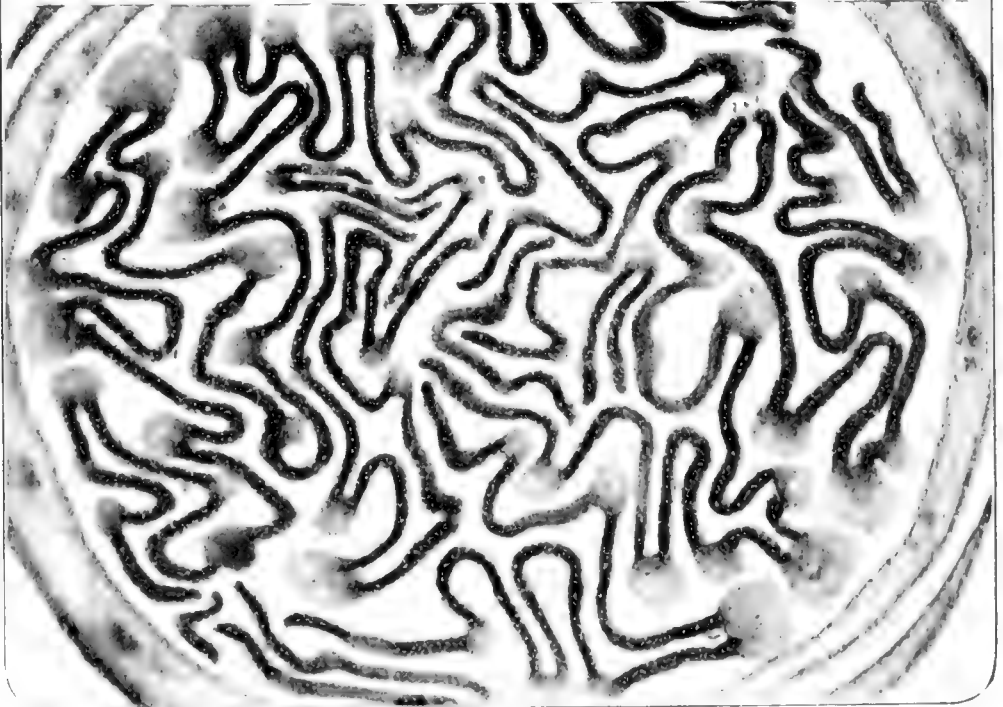

## Not Candy but Moth and Butterfly Eggs

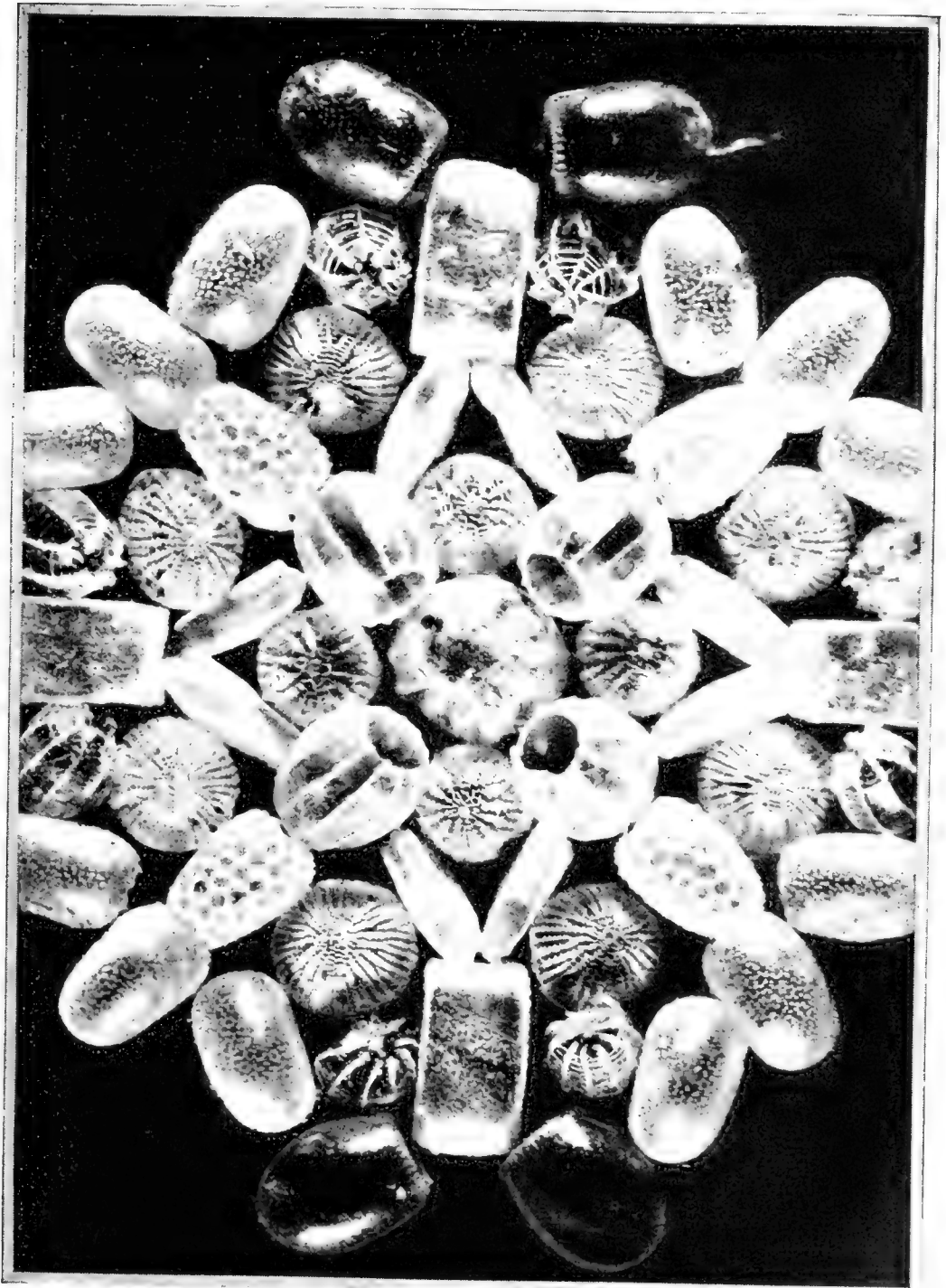

The marvelous forms and beautiful patterns of moth and butterfly eggs as revealed under the microscope. These artistic objects are obtained by covering the eggs with a bell glass before the larvae emerge. After the tiny larvae have crawled out, the fragile boxes are destroyed or mutilated by storms or winds. They retain their form better when occupied

# Japanese Ivory Carvers Working With Modern Tools



Above: Carving ivory with the aid of machine drill. The Japanese have been quick to adapt modern methods to one of the oldest trades in the world

Above: The first process of ivory carving consists in sawing off the pieces. These are fashioned into exquisite ornaments for members of both sexes

Below: Repairing the teeth of a Japanese warrior. This work requires infinite skill and patience. The warrior is only eight hundred years old

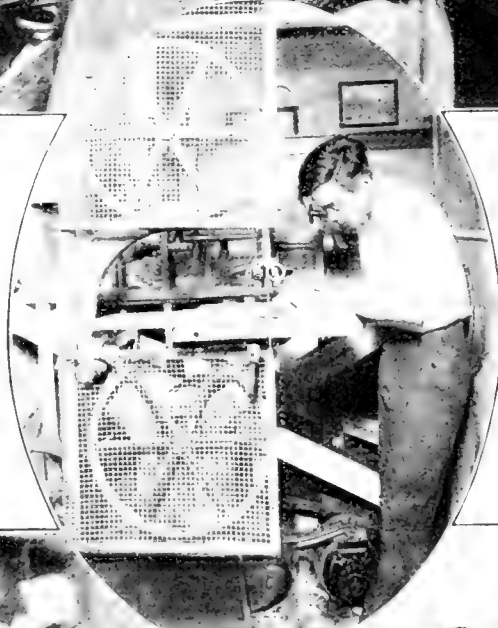

At left: Sawing pieces of ivory with an electric band-saw. Although a quick and modern method of shaping ivory it is not used by the old carvers



**A Danger Signal Used to Direct Attention to Overhead Perils**

**T**HE sign in the accompanying illustration has two uses. It consists of a heavy steel plate, enameled, with a red background and white letters, carrying its warning. When electrical machinery with high-pressure currents is being tested, this sign is placed near the apparatus and the words "High Voltage, DANGER" appear.

When the danger is overhead, as when overhead wires are being repaired or tested, or when a crane is moving loads which might spill or collapse, the sign is placed within the danger zone and a little sheet-metal flap, fixed to the top of the sign, is dropped down showing an arrow pointing upward. The arrow stands out vividly so that anyone passing would not fail to look up as directed, from curiosity if for no other reason, before proceeding. By reversing the small metal flap the sign may be made to display simply the one word "DANGER."



A heavy steel plate used to direct attention upward when the danger is from wires overhead

**A Locomotive Side-Frame Which Weighs Nearly Seven Tons**

**A**LL passenger and freight engines need in their construction what is known generally as a locomotive side-frame. On each side of the engine one of these is used; it assists in forming the main framework on which the superstructure is built.

Until about twenty-five years ago, side-frames were usually forged—a slow and difficult process. Now the cast-steel frame is used. This is made by pouring molten steel into a sand mold. This, after cooling, is removed from the surrounding sand of the mold, and, after cleaning, is carefully annealed in an annealing furnace to make the mass of steel homogeneous.

With the constant growth in the size of the modern locomotives the length and bulk of the locomotive-frame has also increased, until now frames are made that twenty years ago would have been considered impossible. When the one in the illustration was made it was the largest one recorded, measuring forty-one feet seven inches in length and weighing about thirteen thousand two hundred and fifty pounds. The metal is six inches thick. The five openings in the bottom of the frame are for the driving boxes into which the axle ends go which carry the driving wheels. There are five driving wheels on each side.

As steel cools it shrinks, so that about thirty-three per cent more steel is needed to pour a casting than is found in the final product. This extra metal is taken up mostly by sinkheads on the castings which act as fountains or feeders while the casting is cooling. These are cut off and remelted and used in making more steel.



This gigantic side-frame measures forty-one feet seven inches in length. The five openings in the bottom are for the driving wheels, five of which are provided for each side of the engine. It was molded in one piece by the new cast-steel process. The steel shrinks on cooling, so that thirty-three per cent more molten steel, by volume, must be poured in the mold than appears in the finished product

# Catching Fish by Suction

The vacuum cleaner principle applied to fishing on a wholesale scale

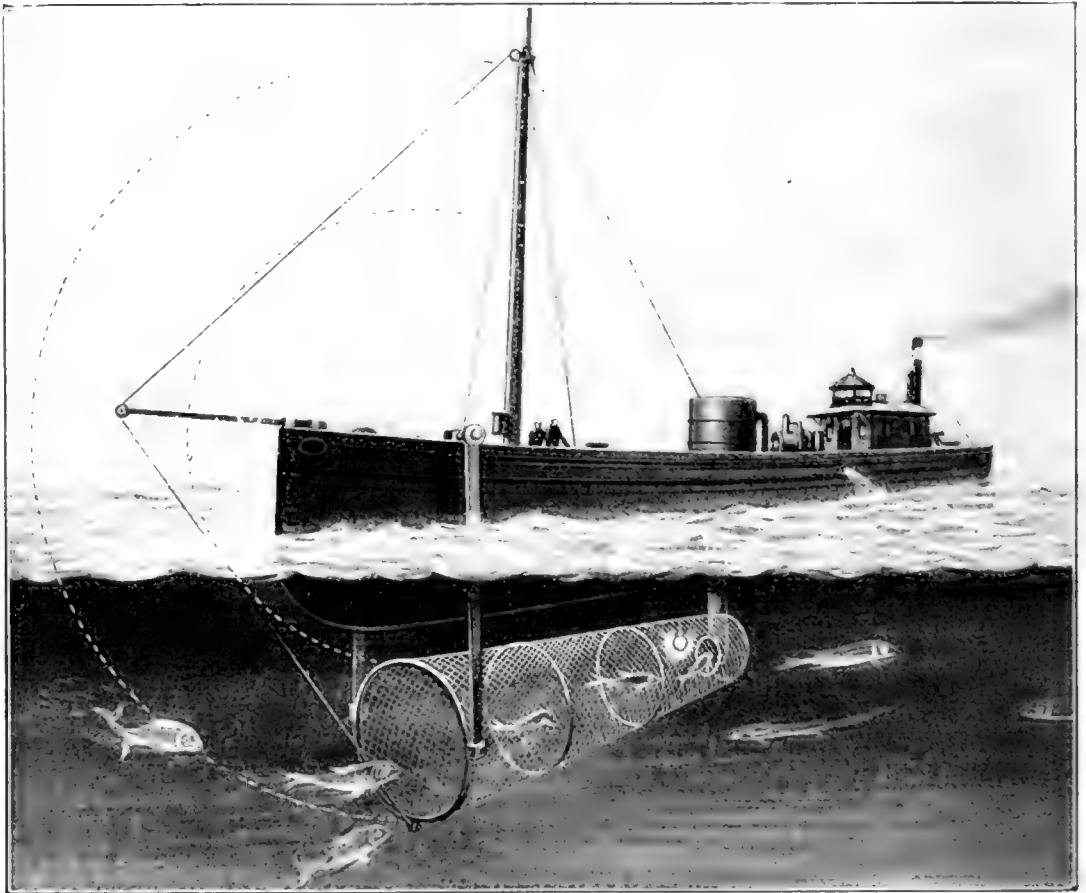

A suction pipe is connected with a funnel-shaped net and a centrifugal pump, by means of which the fish are drawn up and deposited in a container on board the boat

**T**HE fish of the deep are getting wiser, if one can take the numerous devices invented for their capture as a criterion. Nets used by fishermen for centuries are apparently being discarded in favor of more recent fishing inventions. One of the most recent of these is an apparatus for enticing the fish into a net and then drawing them up through a pipe to a container on deck. C. P. Droz, of Nilversum, Holland, is the inventor.

The apparatus comprises a suction pipe connected with a centrifugal pump, a source of light such as an enclosed electric lamp placed in front of the suction opening, and a funnel-shaped net so arranged as to guide the fish to the suction opening. The

fish, seeing the light, enter the net, approach the suction opening and are drawn through the pipe and delivered to a container on deck.

Steel hoops brace the net and strengthen it so that it retains its shape in spite of the action of the waves.

The net is secured at its rear end to the suction pipe and at its front end to a frame pivotally suspended from the boat, so that the net can be removed from the pipe and raised together with the frame to the position shown by the dotted lines in the drawing.

There is a recess made in the boat into which the pipe may be raised and stored away when it is not in use.



**A Field Refrigerator for the Camper or Soldier**

THE illustration shows a very ingenious method adopted by a company in the war zone for storing their food supplies, to keep them cool and out of the reach of the prowling dogs. A large hollow tree constitutes the refrigerator, which has been thoroughly cleaned of all rot. Shelves were set in and a hinged door of wire mesh fastened over the opening. In this case a steel door is used, but the camper can provide one of slats or poles that will serve his purpose as well.

Boyscouts will find the idea attractive. The refrigerator might be located in some favored spot in which an old tree covered with ivy would be available. This would effectually conceal the door from tramps or meddlesome marauders.



© Central News  
To protect edibles from wild dogs which infest the district this food safe was constructed in the hollow of an old maple tree

district. The accompanying photograph shows an adaptation of the caterpillar wheel—the caterpillar tread—attached to an English delivery cart.

Evidently the occupants of the caterpillar cart are agricultural people who live in an outlying district where intermittent rains and heavy traffic have played havoc with roads. By replacing the wagon wheels of the cart with the tread the worst roads can be traveled over with comparative ease. The principal drawback is that travel with the caterpillar tread is slow. On the other hand, the horse sinks just as deep in the mud as he always did. If the vehicle were motor-driven it would meet all requirements. The only other alternative is for some inventor to find an application of the caterpillar tread for horseshoes.

**A Caterpillar-Tread Cart for Conquering Bad Roads**

CATERPILLAR wheels are generally associated with motor-driven apparatus of great weight, such as huge tractors, trench diggers, army motor-truck transports and, of recent exploitation, the "tanks" used by the British in their advance against the Germans in the Somme

**Shooting Soot From Stacks With Blasting Powder**

WHEN powder-plant stacks accumulate enough soot to hinder the draft they can be cleaned by "shooting the stack" with a gun made for the purpose. This is nothing more than a wooden cannon, made of a piece of shafting fourteen inches long. One hole is bored into the center of the

piece and a horizontal hole is bored through the piece to the bottom of the center bore. This completes the cannon.

Blasting powder is placed in the mouth of the cannon to about two inches from the top. This is tamped to the collar with dry clay, and a short fuse is inserted in the touch-hole. The cannon is placed at the bottom of the flue and the fuse is lit.



© Int. Film Serv.  
A caterpillar tread attached to an English delivery cart enables it to go anywhere regardless of the condition of the roads





The engineer's wind shield is fixed to the window-frame of the cab. High speed does not affect its operation

### A Wind-Deflecting Lookout Mask for Engineers

A STEEL mask for railroad engineers which secures for them a clear vision ahead, that cannot be obscured by the snow, rain or sleet, is being tried out on engines of the Canadian Pacific Railroad. The mask, which is attached to the window-frame of the cab, contains no glass, its principle being based on the deflection of wind currents by flanges.

At the top of the shield, curved metal plates, one behind the other, virtually scoop in the air and thrust it downward into a short air-chute, which ejects the draft automatically. Between the upper plates and the chute is a broad slit, through which the engineer has an unobscured vision of the roadway.

It is said that this eye-protector is so efficient that a light fall of snow—which is considered to be the most trying of conditions—will have no effect upon it. Another experiment, which attested to its efficiency, was made by lighting a match behind the gap. The flame was drawn forward. The speed at which the train is traveling does not affect the operation of the shield.

### An Adjustable Steering Device for the Farmer's Tractor

NOW comes the self-steered light farm-tractor, so built that the operator can give more attention to his plows and that any irregularities in the furrows are compensated for. Two disks, mounted on a rod attached to the axle of the front wheels, are set so that their rims or edges are closer together at the front than at the rear. The outer disk is larger and is set lower than the inner one, so that, when placed in a furrow, it pushes the inner one against the land-side of the furrow. The tractor-wheels are prevented from swerving by the pressure of the inner disk against the land-side of the furrow.

The disks are mounted on a rod supported by chains, pulleys and a lever, which raise them from the ground for turning corners or for moving the tractor from the field.

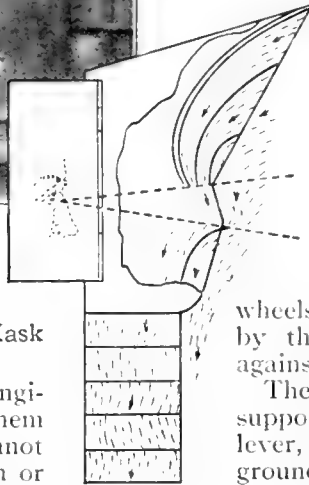

LIFTING LEVER AND CHAIN CONNECTION ON LIFTING ROD

LIFTING LEVER STEERING DEVICE, CHAIN

CHAIN SHEAVE SUPPORT ANGLE

LARGE STEERING ROD STEERING POLE FORK LARGE BRACE ROD BRACE ROD CONNECTION

SMALL BRACE ROD FURROW WHEEL



The device is adjustable so that the tractor will run almost any desired distance from the furrow

# Making Air Fit to Breathe

Experimenters are washing it and filtering it in order to free it from dust and bacteria



To test air for bacteria a film of gelatine is exposed for three minutes. It is then placed in an incubator for two days at the temperature of the room



In center above: The rate at which fresh air is supplied to each person is obtained by filling bottles with air and analyzing it for carbon dioxide



No more than fifty thousand particles per cubic inch should be present under the microscope, although some samples have shown twenty million

At left: a gelatine plate after two days of incubation. No more than twelve large colonies of bacteria should result from the air in any room

**I**T is only recently that health commissions have studied all the conditions that have to be considered in mechanically counteracting drowsiness and the sore throats we get from being shut up all day in our offices, factories, or schools.

Already many important and interesting facts have been brought to light. One of the discoveries which will change the beliefs of many of us is that the carbon dioxide exhaled in our breath is practically harmless; it is only when it amounts to quantities eight to ten times the quantity found in the best air that we begin to be uncomfortable. Nowadays, an engineer will analyze the air of a room for its percentage of carbon dioxide only because this percentage furnishes the best and quickest indication of the number of cubic feet of

fresh air which is required for each person.

Important work has been accomplished by the Chicago Commission on Ventilation in determining the exact effects of the humidity, or moisture, of the air upon comfort. They have found that a cold room can be made as agreeable as one that is warm, simply by increasing its humidity.

Dust in the air of a room also lowers the vitality of the people in it, when it is present in 3,000,000 or more particles per cubic inch.

We now understand why the previous systems of ventilation—of which some are still in use—were not satisfactory. In these systems only the supply of air and its temperature were regulated. They lacked the means to moisten and dry the air and to cleanse it sufficiently of dust.

# This Destructive, Gnawing Fire, in a Mammoth Grain Elevator



When the big grain elevator at St. Bernard, Ohio, caught fire, it was a year later before the flames were finally quenched. The fire worked its way to the very bottom of the grain bins. Water seemed

## Preventing Dust Explosions and Fires in Grain-Separators

UNUSUAL interest has been awakened in the Pacific Northwest during the last two seasons by the large number of fires and explosions in grain-separators. These fires and explosions were most frequent in the wheat-growing territory in eastern Washington and northern Idaho. Similar explosions have occurred in scattered localities throughout the territory lying west of the Mississippi River.

For some time the Department of Agriculture has been studying dust explosions in grain mills, elevators, and similar plants. The close relation of thresher explosions to the general study of grain-dust explosions led to the inauguration of a special investigation of this allied problem in the northwestern field during the 1915 season. As a result of this study one hundred and sixty-six fires were investigated and reported.

The investigation indicated that the wheat crop contained a large percentage of smut (a form of very fine, dry dust) and that the explosions and fires in many cases were due to the formation of an explosive mixture of smut-dust and air and the ignition of this mixture by static electricity during the threshing operations. In almost all cases the flame from the explosion and fire was blown into the straw pile, and in many instances spread to the stacked grain and also to the unthreshed grain in the field. As a result several hundred acres of

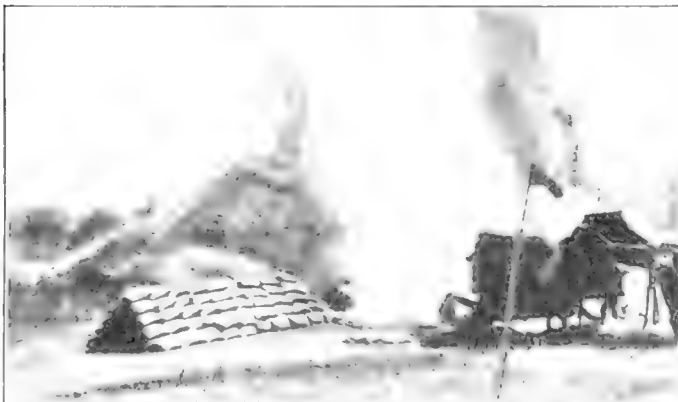

A smut dust explosion in a threshing machine. The photograph was taken at the instant of the explosion and fire

# in Ohio, Burned For More Than Twelve Months



only to add to the intensity of the heat. It was estimated that a million gallons of water were poured on the fire without subduing it. The smut-dust theory is advanced as the cause of it

grain were destroyed. The grain loss due to the fires investigated reached about \$50,000.

The experimental work carried on during the investigations proved conclusively that, under favorable atmospheric conditions, static electricity is present on all types of machines. It appears that the largest discharges of static electricity were obtained from the steel machines.

The fires and explosions occurred, as a rule, when fall wheat was being threshed, and very rarely occurred during the threshing of spring wheat. The discharge from the machines, while smutty wheat was being threshed, was more noticeable than when clean wheat was going through the process. Fall wheat, as a rule, contained much more smut than spring wheat. The theory was advanced that the small particles of smut easily became electrified when the kernels were broken up by the cylinder teeth and that each particle became charged with static electricity.

From a study of conditions, several methods have been developed for preventing explosions and fires. The investigators believe that a system of electrical connection between all of the moving parts and a common wire, and a thorough grounding of this common wire, will prevent a large percentage of the fires that are due to the presence of static electricity and an explosive mixture of smut-dust and air. Several methods of wiring are recommended, the system varying with the type of machine.

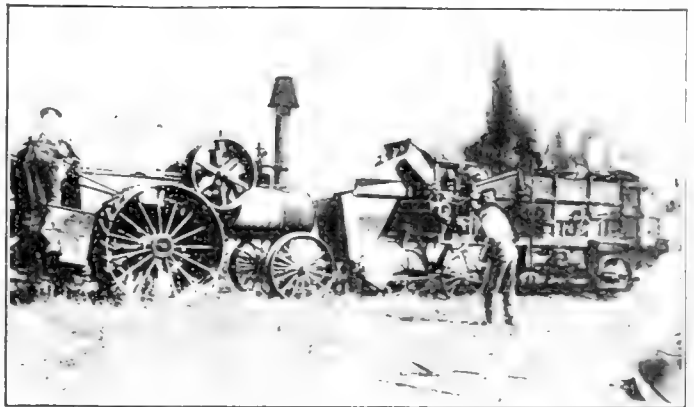

Pulling a threshing machine away from a straw-stack after an explosion and fire, to avoid a greater conflagration

### A Mechanical Printer for Fac-Simile Letters

SOME years ago H. P. Hansen, of New York city, was the publisher of a newspaper. He had occasion to mail large quantities of fac-simile letters advertising his publication but he found the printing of the letters expensive. Finally he invented an instrument that appears to be as revolutionary in its line as the Mergenthaler Linotype is in the newspaper field. He calls his creation Autotype.

It is a machine about six feet in height, provided with a magazine that contains the type, which is released by means of a universal keyboard. There is a great advantage in this, since the office stenographer can compose the type without any previous experience. The composed type is transferred directly to a printing device by an operation that resembles the movement of a typewriter-carriage. When the matter to be printed has been composed and transferred to the printing device, the printing is done directly from that mechanism.

When the process of printing is over, that part of the device which holds the type and resembles a portable segment is removed and placed on top of the machine. The slots in the printing device correspond with those in the distributing mechanism so that the types slide by gravity from the former down into the latter. The distributing mechanism is operated by means of a one-tenth horsepower electric motor. The current is taken from a lamp socket.

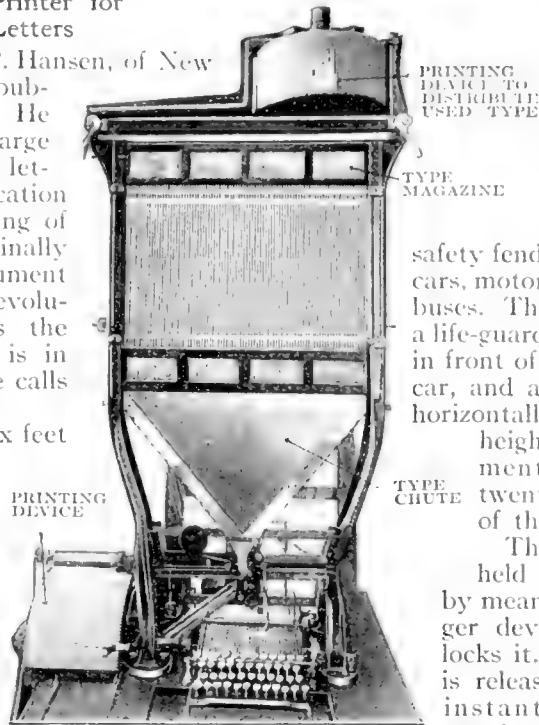

The printing device at left is placed on top of the machine for distributing

### An Automatic Safety Fender Which Sets the Brakes

THE Public Safety Commission of New York has approved a new safety fender for use on street cars, motor-trucks and motor-buses. The fender consists of a life-guard hanging vertically in front of the bumper of the car, and an apron extending horizontally at any required height above the pavement, and projecting twenty-six inches in front of the bumper.

The apron is set and held in normal position by means of a simple trigger device that securely locks it. When the trigger is released the apron is instantly thrown downward and backward to the pavement and is held there by strong springs.

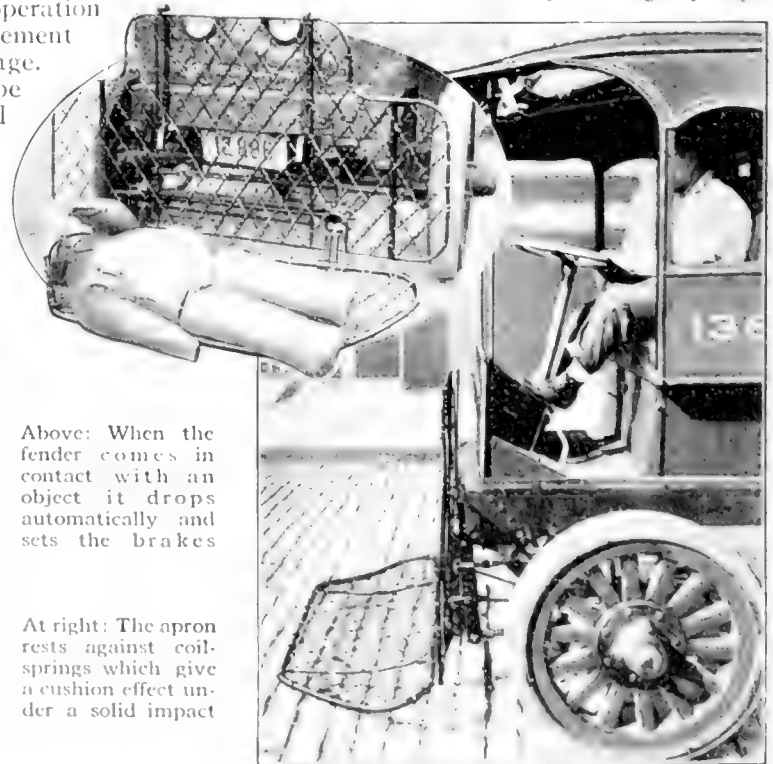

Above: When the fender comes in contact with an object it drops automatically and sets the brakes

At right: The apron rests against coil-springs which give a cushion effect under a solid impact

# The Flying Mail-Carrier

An aeroplane to carry mail on the Buzzard's Bay route seems to the Postmaster General to be the solution of a special problem

THE science of aviation has so far progressed in recent years that now, in the opinion of the Postmaster General and postal authorities, it offers a practical means of carrying mail. To this end bids have been opened for aeroplane service on seven mail routes in Alaska and one in Massachusetts. These routes were chosen because the need of good facilities for mail communication is imperative and because the difficulties of other means of transportation are serious.

The Massachusetts route is across Buzzard's Bay and Nantucket Sound. Most of the route lies over water, and the wind velocities average high during the Fall and Winter. At times fog is prevalent. However, if the exacting weather conditions and weight requirements of the route can be met by aerial carriers, it presents an excellent opportunity for improved mail service.

Two hours is allowed for the flight from New Bedford to Nantucket, with stops at Woods Hole and Oak Bluffs. It is assumed

that in actual service the flying mail-carriers could keep this schedule and have nearly an hour to spare. It is a question whether aeroplanes or hydroplanes, which could start and land upon the water, would be more serviceable.

If adopted, the aeroplane service would reach the population of the islands of Martha's Vineyard and Nantucket. It would supersede service now performed by steamboat. In summer these islands have a large population, which makes the volume of mail nearly double that of the winter. The first or morning trip in summer necessitates carrying not less than three thousand pounds of mail.

At the starting point, New Bedford, the mail-carrying fliers could start about two and one half miles from the postoffice. At Woods Hole, Oak Bluffs and Nantucket satisfactory landing places could be secured one half mile from the center of town. The distance traveled by aeroplane over the route mapped out would be fifty-six miles.

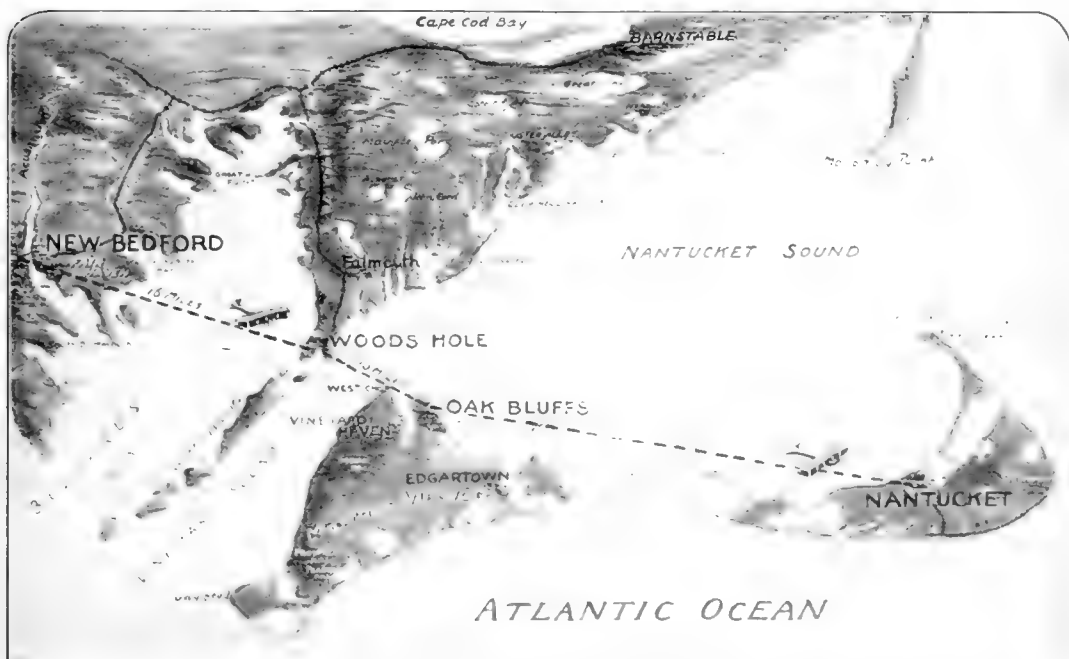

It is fifty-six miles from New Bedford to Nantucket. The Post Office Department allows two hours for the flight by aeroplane, although one hour is said to be sufficient in favorable weather

# Cleaning Sewers from the Street

Many of the disagreeable features of the work are being eliminated

A NOVEL machine which is designed to clean sewers from the street and thus eliminate much of the disagreeable work in the sewer, has been put on the market by a western manufacturer. The apparatus and its method of operation are shown in the accompanying illustrations.

The device consists of two four-wheeled trucks placed at two successive manhole openings and a special steel bucket pulled between manholes by means of a cable, one end of which is attached to a hand-winch on one truck and the other end to a similar winch on the other. The bucket is not necessarily drawn from one manhole to the next, but is drawn into the sewer only far enough to be filled with the deposit and then pulled out of the same manhole in which it was inserted.

This is made possible by the construction of the bucket, which has two hinged scoops at one end so arranged as to close up tight when the reverse pull is made, and also to expand the bucket when it is emptied. Four guard-plates are riveted to the sides of the bucket to prevent excessive wear.

They form a hinge for the jaws. The edges of the scoops are sharpened to cut any roots or growths that might be in the sewer bottom.

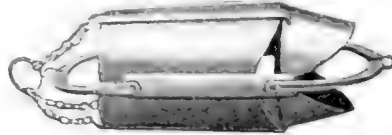

The expansion bucket, which is used with a trolley-jack. The jaws are sharpened for scraping

A special feature of the apparatus is the means whereby the full bucket is

lifted out of the manhole without the cable's cutting into the sewer or manhole brickwork. This is done by means of a guide-jack, consisting of a yoke with ball-joint adjusting-screws at one end and a wedge connection on the other end. This is lowered into the manhole on chains hooked to the manhole-rim, and carries a pivoted arm with a cable pulley. When the bucket is being taken out, it strikes the arm, revolving it upward about its pivot, so that the bucket is guided free out of the sewer-tile and then up the center of the manhole without obstruction.

The sharpened jaws scrape the tile thoroughly so that every particle of debris is removed. When shut they are so tight that nothing in the bucket can escape.

When the reverse pull is made on the cable the jaws of the bucket close automatically so that nothing can escape except the excess water, for

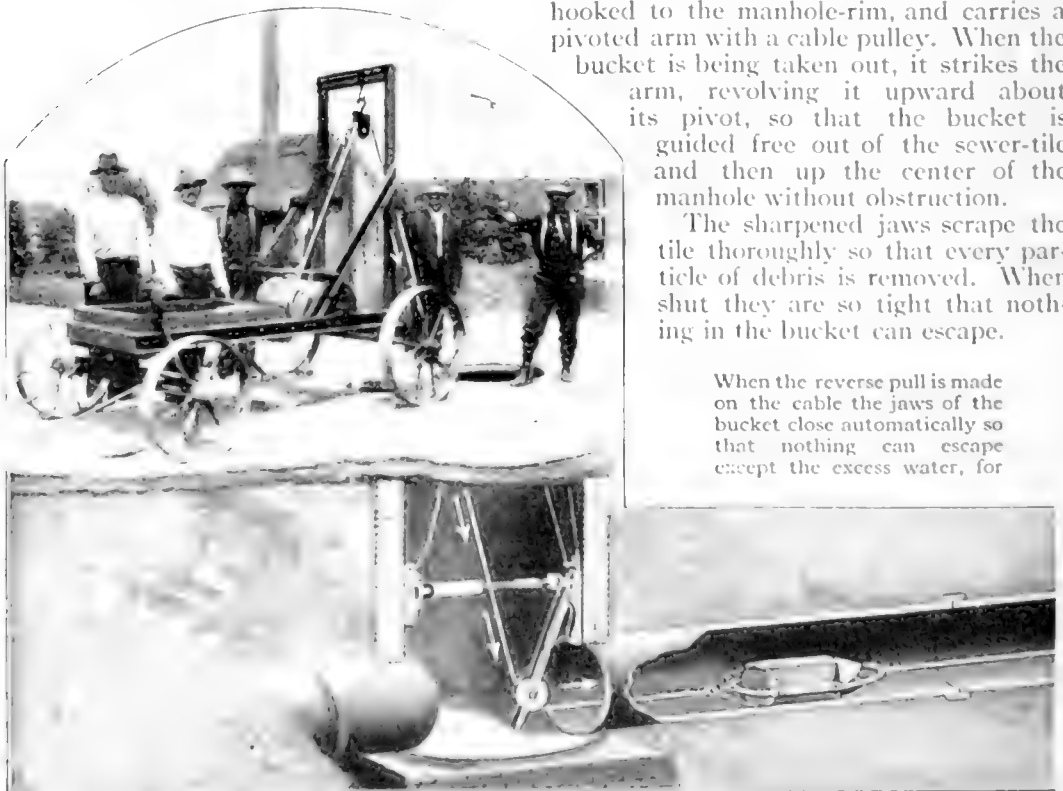



**What Happens in the Stokehold of the Speeding Destroyer**

**T**HE soldiers who fight with least recognition in the battles at sea are the stokers of the destroyers running at full speed. Eight men work under the command of a stoker petty officer, in a space so narrow that movement of any kind seems impossible. There is a furnace in front and one in the back. Sandwiched in between is a maze of levers, pipes, pumps and gear. Yet within these close quarters the stokers find space to perform their heart-breaking toil in an atmosphere almost too hot to breathe. When the men are at their posts, the iron hatch is closed down and the air sucked in through a ventilator has to pass through the furnace before it gets to them.

So long as the pumps work well and the evaporated water is displaced with automatic regularity by fresh, neither the tubes nor the boiler casing can get dangerously hot. But sometimes without apparent cause, the water slowly descends below the level. Sometimes the cause of mischief is a leakage—a pipe broken or a joint strained that allows the water to escape. If it can be remedied, well and good. But if not and the water continues to drop steadily, the stoker petty officer has but one duty to perform—to keep the hatchway from being opened by the frenzied stokers, thus allowing the flames to escape and destroy the entire vessel. The heroes who perish in the stokeholds like so many rats caught in a fiery trap are not even listed.

**The Sentinels of the Sky Above the War-Zone Trenches**

**S**ENTRIES and sentinels have always held a prominent place in pictures and histories of war-times; but it remained for the present war to develop the sentinels of the sky. These are lines of balloons, each balloon about a rifle-shot from the next, and moored about two or three miles behind the front line of trenches, forming a dotted line in the sky which runs roughly parallel with the real front of the battle.

With unwinking vigilance the sentinels in these balloons scan the sky above and around them and the earth beneath them through powerful glasses. Although so high up that they appear to be nothing more than tiny smudges on the grayness of the sky, they can pick out so small an object as a suspicious-looking automobile dashing along through a fog, and will signal the artillery in time to stop its progress.

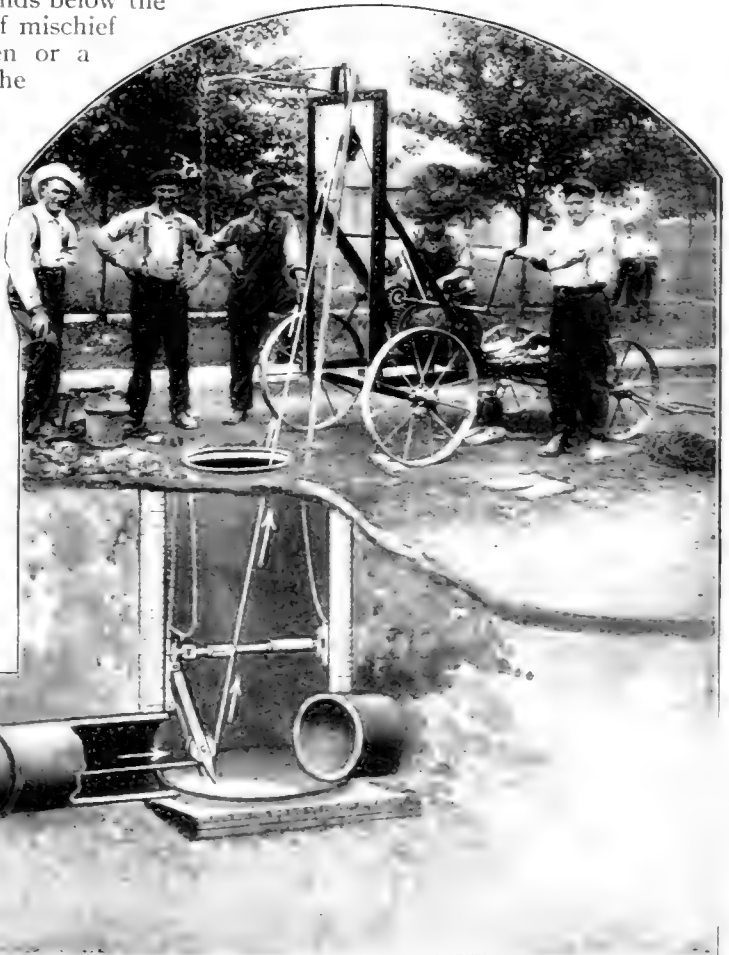

which space is provided along the sides of the bucket. The sewer pipes are freed of everything they may contain, even plant roots being torn out

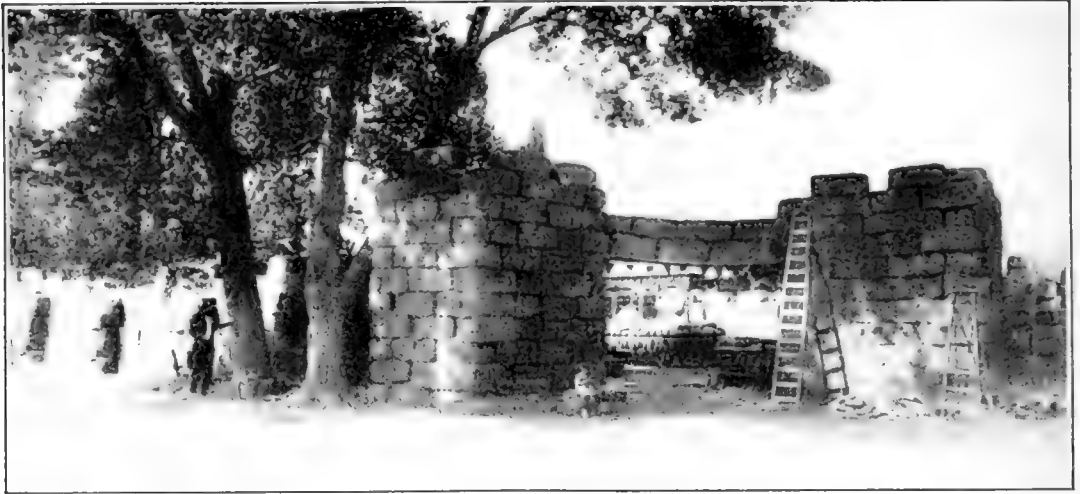

A palace of alfalfa was the attraction at a harvest festival held at Bishop, California. Cows and horses later consumed it, and enjoyed it as much as had the residents of the community

#### A Palace Which Was Eaten by Horses and Cows

AT a recent Harvest Festival held at Bishop, Cal., the principal attraction was a great palace built of alfalfa. The city of Bishop is located in a hay-growing center, so there was ample material with which to rear the unique structure. Baled alfalfa—more than one thousand tons of it—was used, and a number of men were employed for several weeks on the job.

The palace was designed to be an exhibit hall. It was ninety feet wide and one hundred and seventy feet long, beautifully proportioned, with an imposing entrance and walls turreted all the way around. At night it was outlined with hundreds of electric lights, making a picture more charming than it presented by day. It was built around and under towering Lombardy poplars and other trees, and was open to the sky, but so arranged that all exhibits which required shade were protected.

#### Mistletoe: A Christmas Decoration and a Forest Pest

MISTLETOE, to which so much sentiment has been attached as a Yuletide decoration, has become such a destructive pest in this country that the Government scientists recommend its extermination.

It is a leafy, green shrub commonly found growing upon various species of broad-leaved trees throughout the country, and showing a specially strong sentimental attachment for the oak.

It fastens itself upon the tree—penetrates its tissues, and draws nourishment from it, deforming it and sapping its vitality. Birds feed upon the mistletoe berries and scatter the seeds from tree to tree. The pod in which the seed is enclosed is sticky and pulpy and readily adheres to any part of the tree upon which it falls, whether branch or trunk. When germinating, a spike-like "sinker root" bores through the bark until it reaches the sap, of which it robs the tree.



Two trees dying of starvation but covered with a wealth of mistletoe

**A Singeing Comb Which Prevents Hair Conflagrations**

**S**OME barbers do not differentiate between singeing your hair and burning it.

To eliminate all possible danger David P. Cera, of Iron Belt, Wisconsin, has devised a hair-singeing comb which holds the hair in such a position that only the projecting ends are affected.

The teeth of the guard-comb stand off or are spaced from the teeth of the singeing-comb, so that only the ends that project through the guard-comb are singed.



The barber can't burn your hair if he uses this simple guard comb

pump, the cleansing fluid is forced through a tube out of the spray to the ceiling surface.

A brush is then rotated or otherwise moved by gear and lever.

The used fluid is caught in the drip-pan and conveyed by the central tube to the secondary compartment of the tank. Both tank compartments are emptied by cocks.

A small motor might conceivably be used to actuate the brush, and the labor of cleaning ceilings in large buildings could thus be minimized.

**A Machine for Cleaning Ceilings in Large Buildings**

**S**IMON GOTTLIEB of New York must know something of the neck-craning difficulties of cleaning a ceiling. We judge so because he has invented a portable contrivance comprising a tank on wheels with a superstructure consisting of a movable or rotatable brush on an adjustable arm; a spray, also on an adjustable frame; and a centrally placed drip-pan to catch all spray and drops of cleansing fluid falling back from the spray funnel or ceiling.

The tank is subdivided to contain both the cleansing fluid (in the shaded section) and the dirty water conveyed from the drip-pan.

When air-pressure is applied through a

**Utilizing the Waste from Welsbach Mantles**

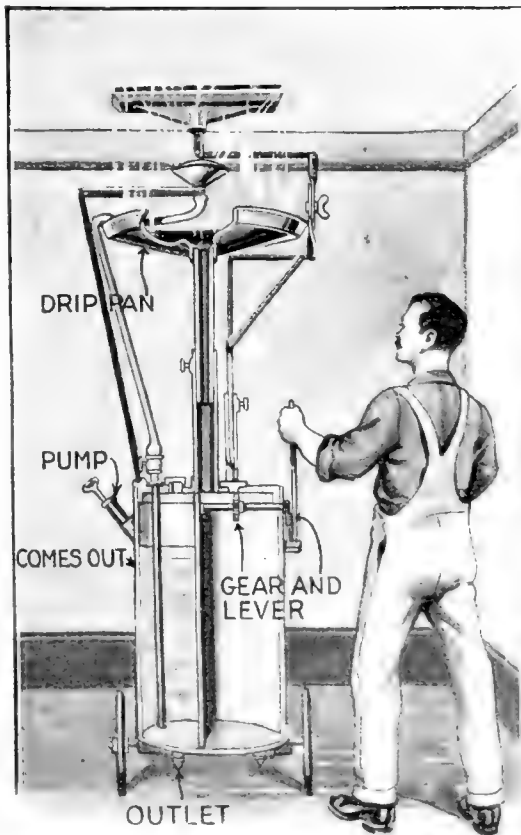

Water is forced against the ceiling surface and a rotating brush moved by a gear and lever cleans it

**I**N making Welsbach mantles most of the raw material is wasted. About fifty per cent. of that is cerium. You light your cigar with that cerium, probably. Combined with alcohol, it produces alcohol-igniting sparks when scratched. If a Welsbach has brains enough to devise a mantle, depend upon it he has brains enough to devise a spark-producing alloy out of the waste left in the manufacturing process of the mantle.

If you wonder what makes the flame of certain electric arcs so white, attribute it to cerium. The waste of the Welsbach mantle industry actually serves to stimulate a rival of the Welsbach mantle itself.

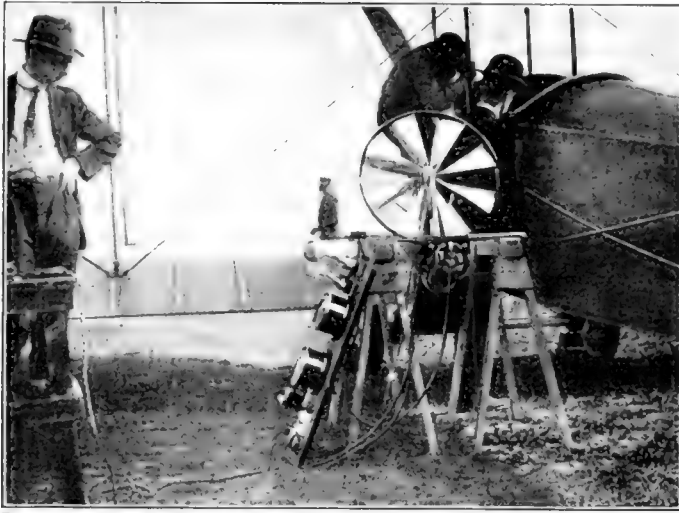

© Amer. Press Assn.

The fan spins like a great pin-wheel when the aeroplane is under way and produces the power to drive the dynamo

### Making the Aeroplane Generate Its Own Power for Wireless

**T**ELEGRAPHING from aeroplanes by wireless has become an ordinary occurrence in the European war zone. But some trouble has been encountered in securing the power to send the messages. The wireless transmitter on an aeroplane must, of necessity, be very light and compact, but it does not require a great amount of power.

Batteries are not regarded favorably for the purpose because it is practically impossible to send messages far without increasing the number and size of the batteries until their weight becomes prohibitive. A few of light weight will not produce sufficient voltage.

By far the best plan tested thus far involves the use of a small dynamo which generates directly the alternating current necessary. It is arranged to be driven through gears or by a belt from the main gasoline motor of the aeroplane. Or it may be driven indirectly by means of an "aerofan" as shown in the illustration. This fan spins like a great pin-wheel when the aeroplane is under way, producing power to drive the dynamo.

ance-lever. Then the small weight which measures pounds and fractions of pounds moves out to the balancing position and stops. The balancing weights are drawn along the beams by small motors which are automatically cut off when the beam balances. The interior light enables the

patron to read clearly the weight indicated.

The invention also embodies a novel percentage-paying device, separating the cash into two cash boxes, one intended for the profits resulting to the place of business where the machine is being operated and the other for the owner of the machine. When the owner's slot is filled, the next coin is diverted into the lessee's cash box and in its course strikes a trigger which releases the owner's cash into its separate box.

The machine, moreover, displays almost human intelligence in the discrimination which it makes between the genuine coin of the realm and counterfeits or slugs, invariably handing back to the customer any substitution.

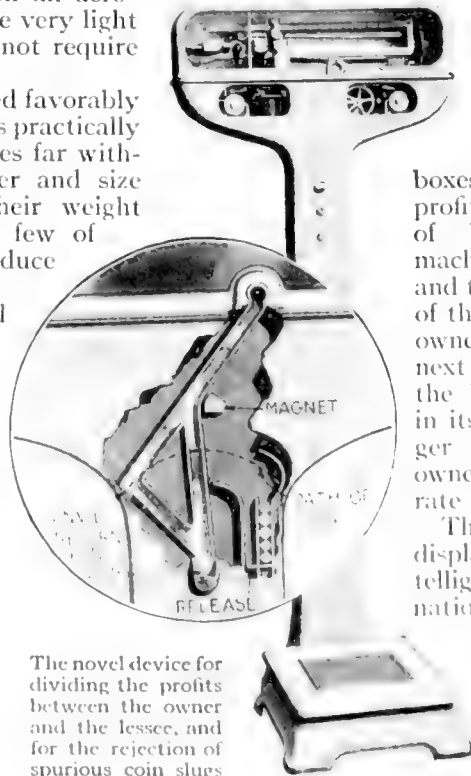

The novel device for dividing the profits between the owner and the lessee, and for the rejection of spurious coin slugs

**Teaching Music by the Picture Method**

ONCE in the days almost beyond recall, learning the alphabet was the first step toward a possible college presidency; but now children are taught to read at the very beginning of their school work. They learn to visualize phrases and sentences by associating pictures with groups of words, and they get through several story books in the course of a year instead of one little primer.

The same sentence-word-phonetic method is now being applied in teaching rudimentary music. An electrical apparatus called a "music optigraph" has been invented for the purpose by B. F. Miessner. It consists of a small keyboard, the keys of which are connected with small incandescent bulbs behind a musical staff printed on glass, on which any combination of notes from two to five in number, within the range of an octave and a half, may be flashed before a student. Thus, whole phrases are visualized at once, instead of being pieced together note by note; just as, for instance, the picture of a tree and the words "This is a green tree" are visualized by the child learning a language by the modern method.

The range of the instrument is from middle "C" to the "G" above, and musical phrases are flashed by pressing lettered push-buttons corresponding with the notes desired. The staff lines are printed on dull, semi-transparent sheets of pyrolin or celluloid, behind which are the flashlights. The notes appear on the lines and spaces of this staff as solid ovals of soft red light when the buttons are pressed. The instrument is

self-contained in a mahogany case resembling a suit-case. The upper part contains the staff, lights, etc., and the lower part the push-buttons, batteries and pitch pipes. The flashlight type of battery is used.

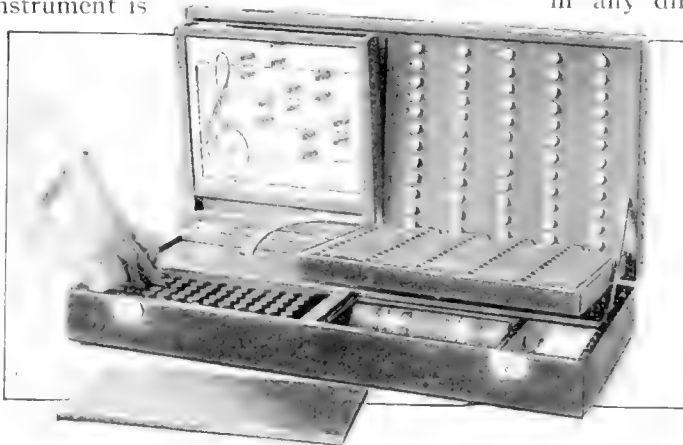

The electric optigraph which teaches the elements of music by causing the pupil to visualize whole phrases at once



The lamp has thirty feet of cord wound around a reel. A swivel enables it to be extended in any direction

**An Extension Reel for Electric Lamps**

WHEREVER an extension light is needed or desired, as in garages, blacksmith shops, factories, stores or even in the amateur workshop, this automatic reel for the cord will be appreciated. It is equipped with thirty feet of lamp-cord and is secured to the wall or any other convenient place through the arms of a swivel-joint.

This swivel-joint is a special feature of the device. It enables the man to walk in any direction with the light. An automatic lock is provided to hold the lamp any specified distance from the reel.

When it is desired to shorten the cord, a slight forward pull unlocks the ratchet, the reel revolves and winds the cord back.



The new type of granite block pavement is laid in concentric interlocking rows, called the oyster-shell pattern

### The Old-Fashioned Heavy Paving-Block Gives Place to a New Form

A NEW type of granite block pavement, almost as smooth and as easily cleaned as asphalt, is finding favor as a wearing surface for streets of dense traffic. Instead of heavy rectangular blocks seven and eight inches deep, the new practice is to specify cubical blocks of from three and a half to four inches, the depth of the ordinary brick.

The new type is laid in concentric interlocking rows, called the oyster-shell pattern. Because of smallness of the block and the apparent irregularity of joints, a good foothold for horses is obtained. Another advantage is that opposite wheels of the vehicle are not on the same course, thus lessening shock and more evenly distributing the load on the base. The small block also allows more of the depth of the pavement to be made up

depth. Small granite cube pavements have been used extensively in many English and European cities as well as in South America for several years.

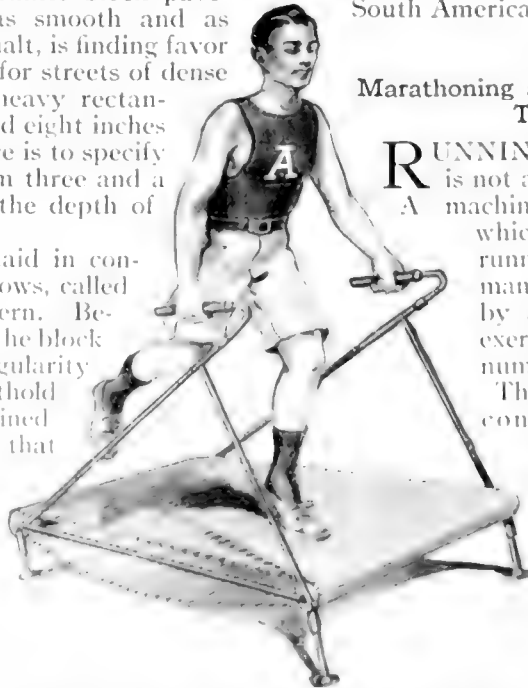

Simply grasp the handlebars, pick out some imaginary object on the distant horizon and expend your energy in an effort to catch it

of substantial and comparatively cheap concrete base material.

The method of laying the blocks as followed on the new Brooklyn-Brighton viaduct in Cleveland, Ohio, is typical. They are laid in a cushion of dry sand and cement, mixed in the proportions of three parts of sand to one of cement on the concrete base. What is laid one day is thoroughly wetted down at night so that the blocks are made practically integral with the base. The joints between the blocks are then filled with a mortar of one part of fine sand to one part of cement. In Cleveland the contractor is paid \$2.50 per square yard for labor and material for the cushion, blocks and grout. The cost of base will depend on its

### Marathoning at Home on a Special Tread Mill

RUNNING a marathon at home is not as difficult as it sounds.

A machine has been devised which makes it easy for the runner, including the fat man who wishes to reduce by adopting this form of exercise, to run at home any number of miles he desires.

The machine as illustrated consists of a wooden tread tightly drawn over rollers. The whole apparatus is supported on steel legs, and when not in use can be folded up. Handlebars enable the runner to exert an additional force while he is running, and prevent him from falling off.



**An Electric Endless-Chain Barge-Loader**

A LARGE jobber of building material at Wheeling, West Virginia, recently had a serious problem to face in the way of expensive handling of materials. On one large contract he had no place to unload his materials from the barges on the Ohio River except at the public wharf. No permanent unloading machinery could be built at that point. It was necessary to shovel the sand and gravel into the dump wagons from the barges. Finally he devised the endless-chain loader shown in the accompanying illustration.

This machine is operated by a five-horsepower motor, and current is supplied by the local electric company. By hand-loading, it required two men fifteen minutes to load a one and one-half-yard dump-wagon, whereas, with the loading machine, the same wagon can be loaded in less than two minutes.

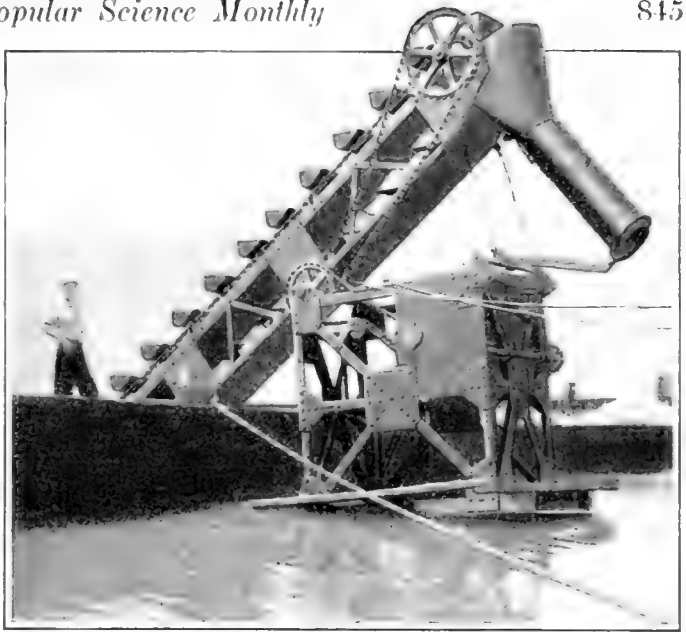

An endless-chain loader built to save time and money in unloading sand and gravel in large quantities

**Stilts Instead of Overshoes for Muddy Crossings**

AMERICANS find it more difficult than the English to understand what Dickens means when he says in *David Copperfield*, "Women went clicking along the pavement in pattens." Pattens were an abbreviated form of stilts. The word is also used by builders as the name of the base of a column or pillar, and so, architecturally, the patten is the support used by a woman to keep her out of the water and mud. From this architectural use has come the secondary application of the word, meaning an arrangement attached to the shoe, as shown in the illustration, so that the walker is raised three or four inches above the solid earth. If the mud and water did not exceed that depth the shoes were thus kept fairly dry.



Pattens—a necessity in the old days

It appears that pattens were not worn solely by the rich, but were luxuries indulged in by the very poor. In speaking of a person who was not especially speedy, Ben Johnson uses the comparison, "You make no more haste now than a beggar upon pattens." In the ballad of *Farmer's Old Wife* occurs this startling expression: "She up with her pattens, and beat out their brains."

This would lead us to believe that although the mothers of those days may have believed in applying a slipper occasionally to that portion of a child's anatomy where there is least danger of inflicting injury to vital parts, it was certainly not done with pattens. In those early times women believed that they must walk in this startling inconvenient way, high in the air, to keep out of the mud and water. Then came the era when rubber overshoes were worn and now, judging from observations made even on country roads, women disdain any protection and go plowing through the mud with thin low shoes, that were white once. There is an awful series of degenerations from the patten to white slippers in the mud.



### Flags Made of Wire. They Wave Even When There Is No Breeze



Flags made of wire mesh mounted on a round iron-rod frame wave forever without becoming tattered

WHEN a flag has been tattered in battles its dilapidation bears witness to heroic service. It calls up pictures of brave deeds and victories won. But the flags that flutter in the breeze over our public buildings are anything but insignia of glory when they become ragged after a period of service.

F. C. Wardell of Boone, Iowa, has conceived a plan to banish the perishable bunting and silk flags except for special occasions, by substituting one made of wire mesh mounted on a round iron-rod frame. The one in the accompanying photograph was modeled from a composite picture of about fifty photographs of a cloth flag in various degrees of wind. It has been mounted on Ensign Peak, Salt Lake City, Utah, as shown in the oval picture.

In position the flag seems to be floating in the breeze, but the undulations are only imitations. The wire mesh is practically indestructible, and it can be painted again and again.

To those who are really patriotic such a flag seems a boon. It not only offers a means whereby the appearance of a locality is distinctly improved but it implies a desire to keep the symbol of national loyalty fresh and well preserved. Its cost is comparatively small.

### A Caterpillar Three Hundred Feet Long

THE Ferracute Machine Company of Bridgeton, New Jersey, on being asked to take part in a local parade, put the matter up to its employees, who conceived the idea of constructing the giant caterpillar, shown in the accompanying illustration.

Works on Lepidoptera were searched in vain for models, and being thrown on their own resources they took a living specimen and magnified its hideousness. The caterpillar they made is three hundred feet long and nearly five feet in diameter, with a head containing features hitherto unknown.

The motive power was supplied by a hundred men wearing pointed caps, ranged three feet apart, the heads and caps projecting through the back. Four hundred yards of green muslin composed the skin, the head consisting of a light framework covered with paper and appropriately painted.

The eyes were made of new tin dishes, inverted, which reflected rays of light in a striking manner.

There were a number of unique features in the parade, but the caterpillar, as it wended its sinuous way through the streets and up-and-down hill, caused the greatest sensation and amusement, so that the participants were given first honor.

The photograph was taken directly in front of the attractive office of the Ferracute Works.

No, the parade was not a feature celebrating the seventeenth of March, although the good St. Patrick would probably not have quailed even before such a monster.



One hundred men, wearing pointed caps, supplied the motive power for this three hundred-foot long caterpillar

An "Armless" and Inconspicuous Baby Carrier

AN apparatus, the principal aim of which is to eliminate the element of drudgery from the operation of conveying an infant from place to place, has just been invented by W. J. Sprong, of Los Angeles, California. The carrier may be used either in the home or upon the street; while the mother is doing the work about the house, or at the time of her shopping tour. One of the features of the device is that when it is used both arms of the person carrying the child are practically free to do other things. Another point which is important is that by its use the shoulders and back are forced to take the weight of the child, rather than the arms. Practically no effort is needed to carry the average baby. With this device in use the go-cart may be left at home, while on rainy days the infant's feet need not be permitted to touch the pavement.



With this carrier the shoulders and back are forced to take the weight of the child

The device may be used with equal comfort either upon or beneath the outside clothing. The part of the carrier which holds the baby may be attached to and detached from the shoulder "harness" in an instant, the basket section being so small that it takes up no more room than a good-sized handkerchief when rolled up and placed in the purse or handbag. It is made of a fabric material and is adjustable to any size.

Daylight Lamp Signals Will Take the Place of Semaphores

A NEW system of signaling which dispenses with semaphores and colored lamps has been adopted on the Pennsylvania Railroad. All indications, both by day and by night, are given by rows of white lights corresponding with the positions of semaphore arms. The system has been in use for more than eighteen months on the twenty-mile line from Philadelphia to Paoli. This line has four tracks and it is one of the latest examples of railway electrification. There is heavy suburban and general traffic and the blocks are three to four thousand feet in length.

In 1914, Dr. Church discovered the possibility of securing long range from a small lamp arranged in the exact focal center of a small wide-angle lens. Following this and in conjunction with Mr. A. H. Rudd, Signal Engineer of the Pennsylvania Railroad, the new signaling system was developed, in which separate light units arranged in rows represented the positions of the semaphore blades, dispensing entirely with the use of lights of different colors. After extensive experimenting, the system was perfected and put into actual service. The signals are used both at block sections and at interlocking plants and are operated both automatically and manually.

In the opinion of Mr. Rudd, light signals are the coming type, and will supersede the present semaphore signals. The only alternative is the possibility of an automatic speed-control system for trains, sufficiently reliable to preclude the necessity for fixed signals of any kind.

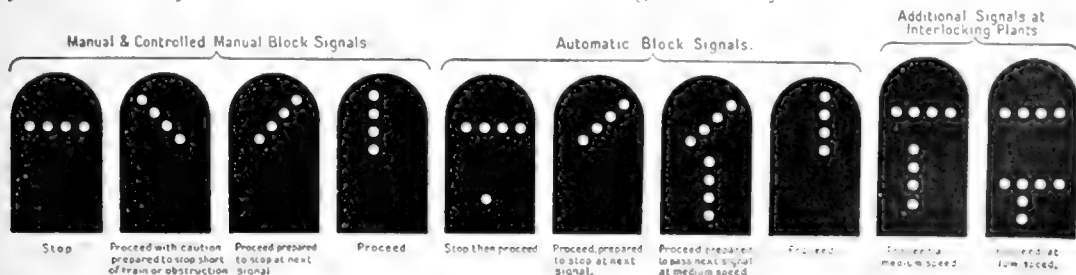

Rows of white lights corresponding with the positions of semaphore arms indicate all signals both by day and by night. These new signals have been given the name of "position lights"

# A Quick Method of Measuring Light

The greater the size the greater the accuracy as a measuring instrument where this kind of a sphere is used

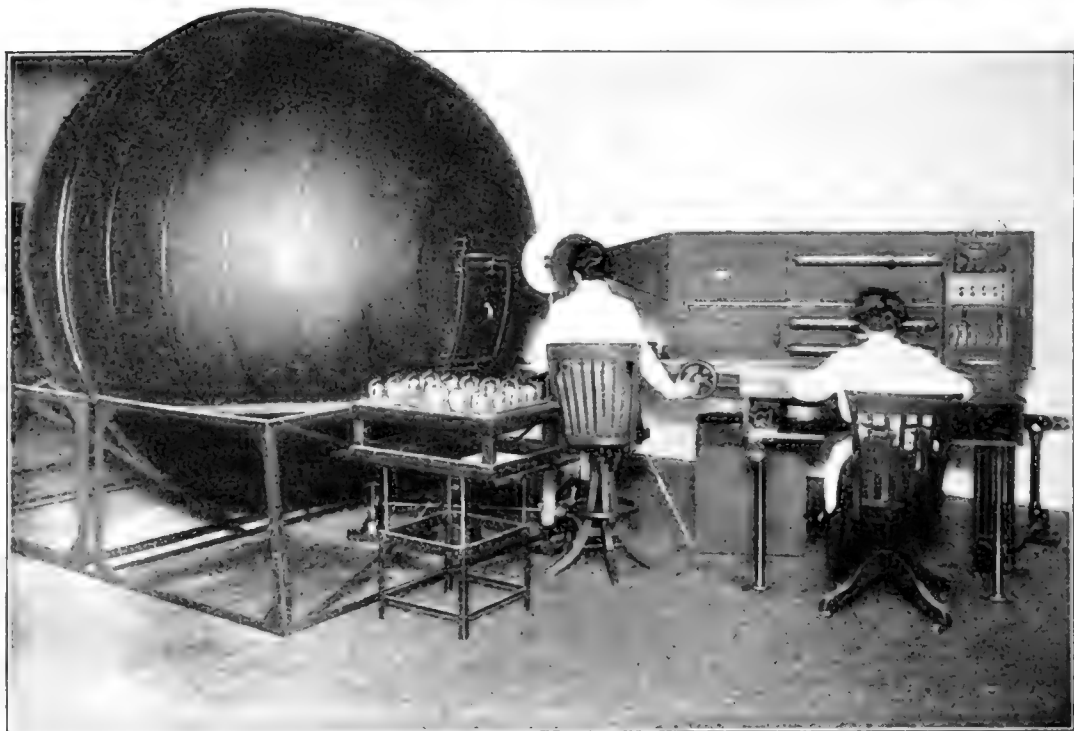

A one hundred-inch sphere photometer used for light-testing work. A sight box, large photometer-bar, movable comparison lamp and scale graduated in millimeters are essential elements

**T**HIS queer-looking apparatus, suggestive of the rind of some Brobdignagian watermelon, is devoted to the innocent purpose of measuring light. We say "rind" advisedly, for the sphere is hollow. It is of a dark color on the outside, and, like the melon rind, white inside, but there the similarity ends, for instead of pulp and seeds one finds at the center of the sphere a whitened fixture designed to hold the electric lamp which is to be tested. The instrument is located at the Nela Park Laboratory, in Cleveland.

Light from the test lamp issues through an opal window in the outer shell and falls on a comparison-screen. In the illustration this screen is being observed by the young lady sitting at the left. Inside the long box at her right is a sliding lamp of known candlepower, against which the test lamp in the sphere is measured.

The apparatus is known as an Ulbricht Sphere; the original form was invented in Dresden by Prof. R. Ulbricht. It operates

on the well-known principle that the interior of a whitened enclosure of this kind is of approximately uniform brightness, and can be used to measure the total light output of a lamp, as distinguished from its candlepower in any one direction.

The principal application is in the measurement of large gas-filled lamps, which, on account of the peculiar coiling of their filaments, vary widely in candlepower distribution and can be rated quickly and accurately only on such an instrument.

This particular Ulbricht Sphere, one hundred inches in diameter, cost several hundred dollars and is the largest in the country. The greater the size, the greater the accuracy as a measuring instrument, since the percentage of reflected light to absorbed light is increased.

The value of the Ulbricht invention as a time-saver may be illustrated by the fact that with its aid five minutes suffice to make measurements that would require fully half an hour under former methods.

**A Device Invented by a Blind Doctor to Enable Himself to Write Letters**

**T**HE greatest sufferers of the present war are the soldiers who have been blinded. To palliate their misery French soldiers who have lost their sight are urged to use the suggestions of a book called "A Blind Man to the Blind," written some time ago by a scientist, Dr. Emile Javal, who, when he found his sight going, tried to prepare himself for his days of blackness. Dr. Javal managed to write the book with his own hand. The device he invented is shown in the accompanying illustration. The difficulty in writing without seeing is that although the first line may be fairly straight the following lines are apt to overlap. Dr. Javal's invention consists of a tablet set on a slide resting on a toothed board. The catch of the slide is pressed by a spring into one of the openings between the teeth of the board, thus forming a kind of rack-bar. The end of the board has a rest for the elbow, which rest keeps the pen at a fixed distance from the end of the slide. By means of the catch and spring the tablet is moved at the end of each line and set in place for the next line. The paper is held on the tablet by a clip; the end of a line can be revealed by the sense of touch.

Dr. Javal made constant use of his tablet until his death. Men of little education can hardly gain as much benefit from such inventions, but as the blind should be encouraged in the use of whatever preserves their individuality, soldiers who have lost their sight will be taught the use of some such method of expressing their thoughts. A plain, unvarnished recital of any one man's experiences in the war would be of real literary value.

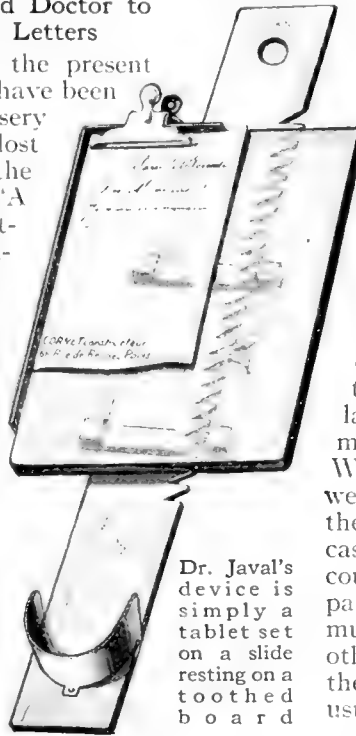

Dr. Javal's device is simply a tablet set on a slide resting on a toothed board

**Why We Remember Those Big Snow-Storms of Youth**

**W**HY do most people believe that the winters were more severe and were attended by heavier snowfall in their childhood days than they are now? The myth of the "old-fashioned winter" is almost universal, and is another example of "counting the hits and not the misses." Heavy snow and intense cold produce a more lasting impression upon the mind than open, mild weather. We remember the exceptional weather of the past, and forget the normal weather. In some cases a change of residence accounts for this belief. Some parts of the country have a much heavier snowfall than others. In any given locality the weather conditions are usually uniform.

**A Medicinal Cartridge-Belt for Peaceful Expeditions**

**T**HE man who is hunting for health instead of for wild animals can wear a medicinal cartridge-belt recently devised by Dr. Otto Sommer, of Seattle, Washington. The belt is made of canvas or leather, as desired, and it has numerous compartments for vials containing medicine, just as a cartridge-belt has holes for cartridges. When a person wearing the belt wishes to take a shot at some internal disorder he plucks a medicinal pellet from the belt and swallows it. If relief does not follow he plucks another of a different kind until his medicinal ammunition is depleted.

At this point he dons another belt fully loaded and repeats the operation. The inventor claims the belt is useful on long walks, trips, and on horseback expeditions.



The medicine vials are placed in separate compartments in the belt as if they were so many cartridges

# Humanity's Bent Twigs

The marvelous ways in which infantile paralysis, joint deformities and hunchbacks are cured

By A. M. Jungmann

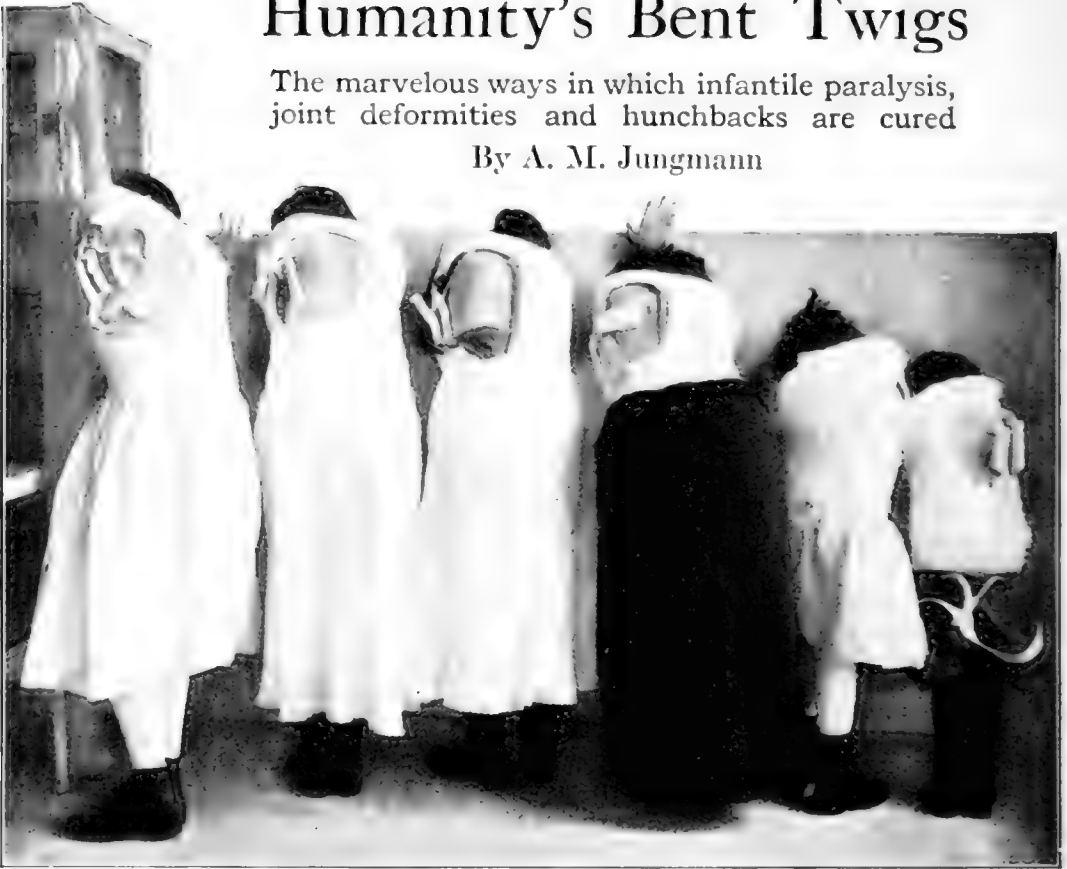

A group of patients wearing plaster-casts to correct deformities of the spine. When the casts are finally removed the backs are as straight and strong as nature intended them to be, and remain so

**F**OUR years ago a young Italian couple living in New York looked forward with eager anticipation to the arrival of their firstborn. They hoped it might be a boy. It was. But their joy was much clouded because the child had no feet. There were no ankle-joints—nothing but a large leg-bone. Just below where the ankles should have been the legs terminated in points. Here was a great misfortune. Never could the child walk. Except for this defect the baby was as fine a boy as one would wish to see.

The other day I saw that baby, now grown to four years of age, run across a ward of the Hospital for Deformities and Joint Diseases in New York city. He ran on flesh and blood feet, not as well, perhaps, as though he had been born with them. But he ran. And we are taught that the age of miracles is past! In orthopaedic surgery it is just beginning.

The boy's parents had heard of the remarkable cases of corrected deformities

which the Hospital for Deformities and Joint Diseases has to its credit, and took him there. They hoped that some mechanical means might be found to enable him to walk—something in the nature of a brace, perhaps.

Dr. Henry W. Frauenthal, the distinguished orthopaedist in charge of the hospital, determined that through an operation the child could be provided with feet made from his own bone and flesh. Accordingly the leg-bones were broken at the place where the ankles should have been and then reset at right angles, to form feet. To be sure, these feet have not the spring, the resilience, of natural feet; but the boy need never be dependent on others because of his inability to walk. His general health will be much better, since he may exercise naturally.

Each day five hundred afflicted persons attend the clinic at the Hospital for Deformities and Joint Diseases. It is the only New York hospital that accepts chil-

dren under four years of age and over sixteen. This explains the size of the clinic, one of the three largest in the world. Under the Frauenthal method a young baby may be treated for deformities, such as club feet and hands, because the hospital accepts children from birth. At the time of my visit to the hospital for the POPULAR SCIENCE MONTHLY, the youngest patient

human waste this means. Think of suffering an amputation because there is no place where one can go where a diseased joint can be restored. A man lacking an arm or a leg depreciates in value to himself and to the community.

*Cleaning Teeth to Save Lives*

The science of orthopaedy has some



Above: Exercises to regain control of paralyzed muscles and to straighten spines

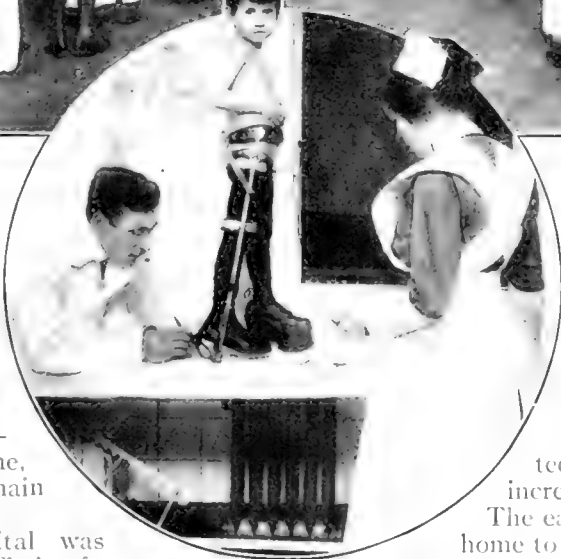

To the left: Adjusting a traction splint to correct a shortened leg

was four days old. Cases requiring hospital treatment are accepted and kept in the institution until their difficulties are overcome, if they have to remain a year.

Before the hospital was established a man suffering from a chronic affection of a joint, for example a knee joint, would have been sent from one hospital to another until, in despair, he would finally consent to have the leg amputated. The ordinary hospital is not equipped for orthopaedic work. Its facilities are overtaxed in caring for acute cases. There is neither time nor room to treat chronic cases. Think of the terrible

amazing features. Many men—and women—have been rescued from living the lives of hopeless cripples simply through having their teeth cleaned. It seems incredible; yet it is true. The easiest way to bring it home to you is to tell you the stories of some of the sufferers who have been cured by this extremely simple means.

A detective who had to walk much, suddenly began to experience trouble with his feet. For two years he was treated for fallen arches. He could not obtain relief. His feet became more painful every day. At last he was advised to go to the Hospital for Deformities and Joint Diseases. By



Picture continued on next page

A group of children suffering from infantile paralysis receiving massage. These patients generally are under five years of age, although the disease sometimes attacks much older children

that time his pain had become well nigh unbearable. He could not move about even with the aid of a cane, and was forced to give up his work. At the hospital his teeth were cleaned. Two weeks later he was free from pain. He discarded his cane and arch supports and returned to work without suffering the slightest inconvenience from his feet.

This case was diagnosed as infectious arthritis, which means an inflammation of the joints caused by an infection. The infection which caused all the trouble had its origin in septic pyorrhea, a disease of the gums, sometimes called Rigg's disease, caused by an infection of the tissues surrounding the teeth. Particles of food lodge in the crevices of the teeth, decay, and become breeding grounds for germs. Tartar forms at the base of the teeth in little pockets. If this is neglected, small pockets of pus develop which fill with bacteria. The pus discharges in minute quantities, passes into the throat and enters the intestines. Sometimes the micro-organisms it carries establish themselves in the tonsils. The result? Tonsillitis. If the bacteria pass into the alimentary canal they are absorbed by the system and set up inflammation at the point offering least resistance. This frequently is found in the knees, elbows, or the joints in the feet. Do you wonder now what was the matter with the detective?

Sometimes people suffer for years from what they consider inflammatory rheumatism. They resign themselves to a life of pain when all that is necessary to obtain relief is to have their teeth cleaned. One

woman, treated at the Hospital for Deformities and Joint Diseases, suffered so from this form of joint infection, which she thought was rheumatism, that she twice tried to commit suicide. For nine months she was without the use of both knees, both wrists and the left ankle. She was bedridden. She was carried into the hospital on a stretcher. Ten days after her teeth were cleaned she walked out a well woman.

#### *The Effects of Infantile Paralysis*

Actual deformities may be caused in children and adults by a number of diseases chief among which are tubercular affections of the bones, of the spine (Potts Disease), infantile paralysis and venereal diseases.

Of these perhaps the most spectacular is infantile paralysis. It is given that name because it attacks children and paralyzes its victims. It is communicable. New York experienced an epidemic in 1907, and during the past summer another swept over certain districts of the city, causing the greatest anxiety and terror among parents. And well it might; for the most wholesome, sturdy child may be reduced to a hideously deformed cripple through its ravages.

At the Hospital for Deformities and Joint Diseases there are always a number of children undergoing treatment for infantile paralysis. The disease is prevalent, more or less, all the time. But the general public hears little of it, unless, as was the case last summer, it becomes epidemic.

The Frauenthal method of treating this disease has effected some brilliant cures in cases which had been regarded as hopeless.



A sixteen-year-old boy was treated at the hospital for paralysis of the face. When he was one and a half years of age he suffered an attack of infantile paralysis which resulted in loss of control of the muscles of the right side of his face and of his right arm. For fourteen years, day and night, that boy's right eye was staring open. He could not close it. He could not use his right arm. His appearance was repellent. After six months of treatment he was able to close his eye and to wrinkle his forehead. The affected side of his face became normal.

Dr. Frauenthal treats infantile paralysis by means of electricity and massage. Whatever muscles are affected are also treated electrically. A muscle which cannot be contracted by will, may be contracted by an electric current. In this way the muscles which do not respond to the patient's will are kept active and developed until they can be controlled by the mind. The treatments last but a few minutes at a time, so that the child's vitality is not exhausted. The current is so carefully regulated that the child does not feel any pain.

Massage is given regularly. If a child's arm or leg is affected by infantile paralysis that limb is strangely cold. Massage will raise the temperature of the affected member

A boy being treated for tubercular joints. He is wearing a plaster cast over the affected hip and knee



The operating room, showing the surgeons completing an operation on a diseased knee-joint, and a group of visiting surgeons watching. On another cot is a patient waiting under an anaesthetic

from 6 to 10 degrees Fahrenheit. Heat is necessary to the development and growth of the limb. Hot baths are also given to float the limb and aid in acquiring motion.

The most interesting part of the treatment is the exercising done before a mirror. The little patient is told to concentrate his mind on the affected part, whether an arm, a leg or any group of muscles, and to endeavor to move those muscles. The mirror stimulates him to put forth his best efforts because he takes keen interest in watching what he does.

#### *What Causes Hunchbacks*

Tuberculous disease of the spine (Potts disease), unless checked, leads to the deformity commonly called hunchback. Children under three years of age are held in bed in an apparatus which gradually restores them to a normal position. Any day you may see a row of these little patients on the balcony of the hospital. Despite the fact that they are strapped in an apparatus, which must be painfully confining to a liberty-loving, active child, they are a happy, cheerful lot.

The average case receives surgical operation. A piece of the shin-bone is removed and placed in the diseased portion of the spine as a wedge. The child is then placed in an apparatus which keeps his body rigid. Here he lies for six months following the operation. The cots are on a balcony which overlooks a park. The patients get all the air and sunlight it is possible to get in a city. Strict attention is paid to diet. These children are fed highly nutritious food. After a few weeks of this treatment it is difficult to believe that they are not in the best of health. If it were not for the apparatus which confines them, one would take them for normal children. When they finally leave the hospital they can run and play like other youngsters. And the beauty of it is, they grow up straight-backed.

Hip-disease is another cause of deformity. The

affected leg is much shorter than the other. The Frauenthal method of treating this employs carefully adjusted splints, X-Ray treatment and special diet. The child frequently is kept in bed, held in a recumbent position by means of straps. The affected leg is clamped in a weighted apparatus which constantly pulls the deformed member. The hip is treated by the X-Ray to stimulate the growth of healthy tissue. After a period of this treatment, careful diet and fresh air the patient is fitted with a splint in which he can walk. Eventually the disease is eradicated and the short leg induced to grow.

The X-Ray is used extensively in the treatment of joint diseases. For certain joint troubles hot, dry air is used. The patient places the affected member in an electric baker and subjects it to a temperature of from 250 to 400 degrees Fahrenheit. Another interesting apparatus is the Zander apparatus for developing the muscles in weak and flat feet. The foot is strapped to the apparatus, which is then set in motion. The machine is capable of a variety of motions designed to exercise the muscles.

Thanks to orthopaedic surgery the human tree no longer has to incline the way the twig is bent. At the Hospital for Deformities and Joint Diseases five hundred bent twigs are started on the road to straightness every day. They come in on crutches, but they walk out on their feet.

#### **A Rescue Saddle for the Fireman Which Leaves His Hands Free**

**T**HE Indian woman carries her papoose strapped in a basket-cradle

on her back, because she must needs have

her hands free for other things. The same idea has been utilized by William De Lude and Albert H. Steele, of Kansas City,

Mo., in the construction of a saddle to be used by firemen in rescuing unconscious or helpless persons from a burning building.

The construction and use of the saddle are shown in the picture.



The victim is held securely by the straps which are buckled to the breastplate and back plate

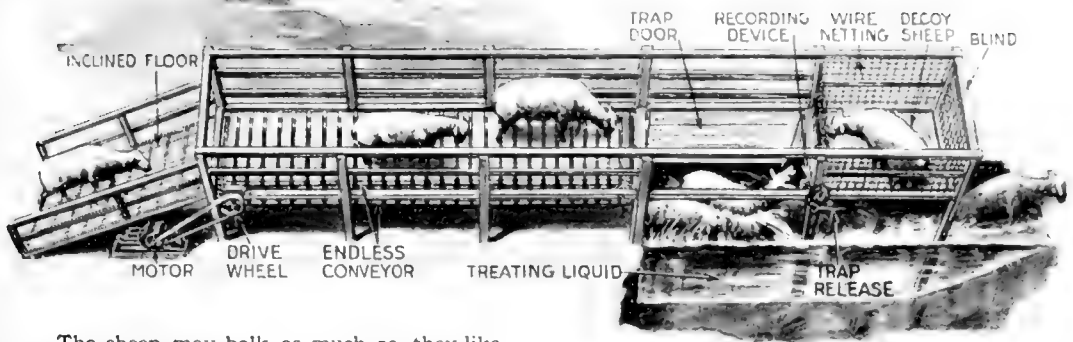

The sheep may balk as much as they like but the endless belt carries them rapidly on

### Sheep May Not Like This But It Saves Time

**T**HE thickness of sheeps' wool provides an excellent lodging place for vermin of all kind. This is undoubtedly warm and comfortable for the vermin, but the sheep and the wool suffer from the unclean presence. On sheep ranches it is the custom to cleanse the stock several times with vermin-destroying liquids before wool-cutting season.

J. J. Roberson, a sheep herder in Utah, who is of an inventive turn of mind, devised a machine which should simplify the performance. In a recent letter to the *POPULAR SCIENCE MONTHLY*, he writes: "Conservatively, we cut down the cost over one-third by dipping the sheep, to say nothing of the saving in time."

The friendly and unsuspecting sheep, which goes through his machine, will probably cherish a deep and distrustful feeling towards man forever after. The animal climbs a short runway and emerges upon a swiftly moving floor, which precipitates him upon a trap-door that opens as soon as it is stepped upon. The sheep drops suddenly into a pit filled with vermin-destroying liquid.

By the time the sheep has collected its befuddled wits sufficiently to crawl out of the pit upon the open field, the vermin have been completely exterminated.

The ingenious feature of this apparatus is the endless conveyor which takes

the animals along to the trap-door no matter how stubbornly they resist—and sheep are the most stubborn of all animals which require dipping. Where one sheep goes all go. That is the inventor's reason for having a decoy sheep in a wire netting to entice the others to go forward.

### A Heater for Use Over the Flame of a Gas-Jet or Kerosene Lamp

**F**OR the small room that is not properly heated, or to use for light cooking in connection with illumination the device illustrated may prove advantageous. The traveler or camper who needs a little hot water for shaving or for a cup of coffee will appreciate it also. It is constructed of sheet-brass with an inner and outer dome.

When the inner dome becomes heated, a vacuum is created, drawing the cold air to it through the openings in the outer dome. The heat does not pass through and out at the top, but is expelled in a downward direction. It can be used on top of a gas-jet or over the chimney of a kerosene lamp.

Although the construction of the heater is strong enough to accommodate small cooking utensils, the amount of weight which it will sustain is limited. The principal use for which it is intended is to supplement the heat of the furnace or other heating system. It will be found especially useful in the bathroom.

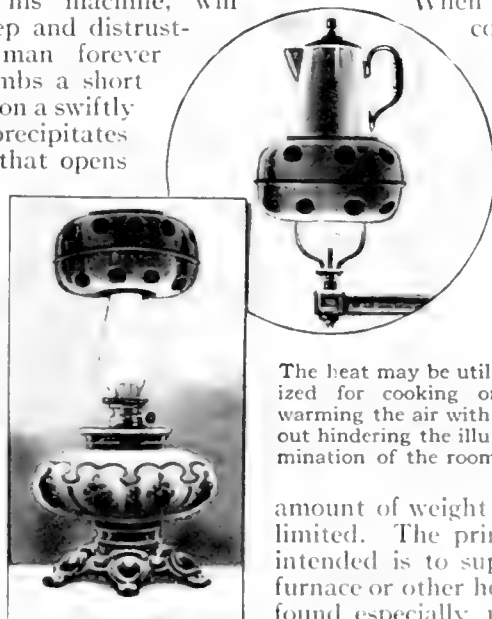

# Eight Pictures on One Plate

The camera may not lie but it can be made to play tricks

A SIMPLE attachment for the camera which enables the photographer to secure a number of exposures upon the same plate or film has been invented by Charlie K. Pugh, of Colorado City, Colorado. Two, three, or four pictures may be taken upon different portions of the plate or film without any line of demarcation showing. Four exposures were made to obtain the photograph in the accompanying illustration.

The attachment is a plate of thin metal with the side edges bent inwardly to form flanges to fasten over the camera-lens, as shown in Fig. 8. Affixed to the front of the plate is a rectangular box and tongue, having sidewalls closed at one end and opened at the other.

When it is desired to take two laterally exposed views the device is adjusted over the camera-lens as shown in Figs. 1 and 4. In other words, it is so adjusted as to leave an opening for about one half or one third of the diaphragm. A light-shield, acting on the principle of a slide in a plate-holder, cuts off the rays of light which would otherwise affect the other half or remainder of the plate.

When two pictures are to be taken on the same plate, one vertically above the other, the device is

in the position shown in Fig. 2. To form the second picture the device is removed and reversed, as in Fig. 3. When four pictures are taken the device is arranged so as to take the two lateral views first, each view occupying one third of the plate. The two middle views are then taken by re-adjusting the device. This gives four pictures on the same plate, one on the left hand, one on the right, and two in the middle, one above the other.

The tongue in the rectangular box, shown in Figs. 5, 9 and 10, is important, since it cuts off any undesired slanting rays.

This is illustrated in Fig. 10. The light coming in the direction of the middle line is desired; the light rays above or below it are cut off by the tongue.

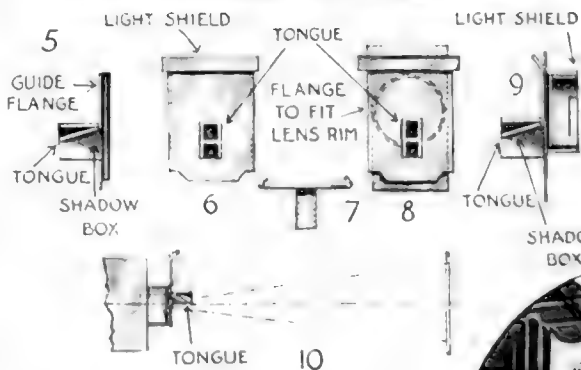
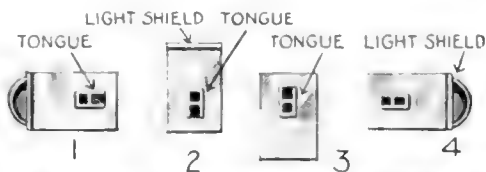

Details of the camera attachment which makes the multiple picture possible

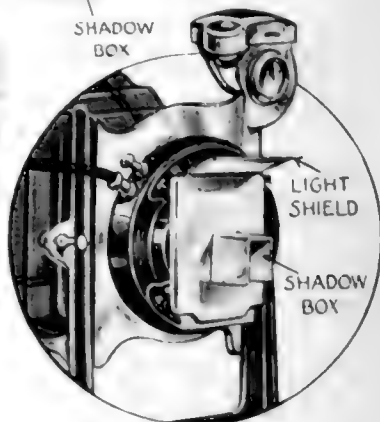

**Things Weigh. Then Why Not Let Them Drop Where They Are Wanted?**

**T**HE principle of potential power which Newton investigated and which the baggage-man puts into practice with your trunks, is being utilized in a recently perfected gravity-roller conveyer in warehouses, factories and other industrial establishments where many large packages are handled. In other words, because things weigh, why not let them drop to their destination?

The contrivance consists of a runway of successive rollers on an inclined plane. The great advantages of the gravity method of transportation are that it requires little attention and is extremely flexible. There are switches and other appliances, by means of which the goods may be diverted around corners or shunted wherever desired.

Besides its cheapness of construction and maintenance, it is always ready to accommodate a load and to handle goods as rapidly as they can be put on the runway. Also, breakage is reduced considerably in comparison with hand-trucking.

One of these gravity-conveyer systems is in operation in a Boston warehouse, where it transports goods of any regular shape from the third floor to an elevator on the second.

**Corns—What They Are and Why They Hurt**

**C**ORNS, like corsets, boarding-houses and late hours, are a menace to one's sweet disposition.

Corns are hard growths which occur on the toes or some other part of the feet. They are generally the result of wearing a shoe too small for the foot. They are thickenings of the outer layer of the skin in the center of which is a nail-like peg which projects downward and hurts when pressed upon. Soft corns form between the toes and are only different from others in that they are soaked with perspiration all the time. The corn itself is composed of a lump of the outer part of the skin which is caused by the pressure of the shoe at that spot. However, the corn would not result unless the pressure were taken off at intervals, and this, of course, is done when you take the shoe off. It stands to reason that if the pressure were continuously applied to this spot, the skin, instead of overgrowing at that precise point, would waste away. The overgrowth of the skin is due to the irritation produced by the pressure.

Shoes play an important part in the comfort of feet and consequently in contributing to the health and general happiness of the individual.



The gravity conveyer reverses the conditions of the bicycle traveling down a smooth road; it contains within itself the wheels

By means of curves, switches and other appliances the conveyers may be run around corners, partitions and over floors

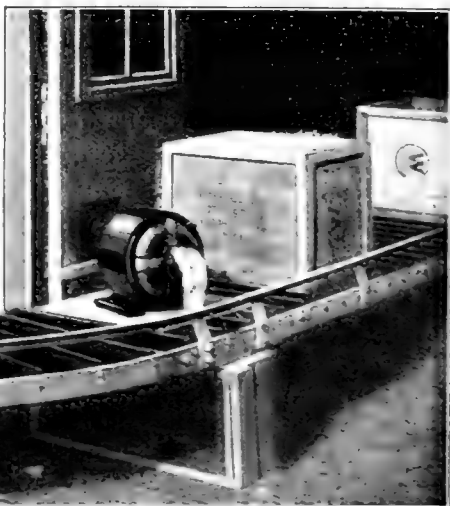

# Housekeeping Made Easy



Above: A gas-stove with five different ovens meets all possible baking requirements

Below: A skirt-marker which is simply a chalked cord clamped to any convenient place



At left: A kitchen drinking fountain attachment of the "bite the bubble" variety

Below: The soap won't slip into the water when this attachment is on the board



Below: A space-saving phonograph cabinet with a sliding top. To obtain a record the phonograph is slid to one side

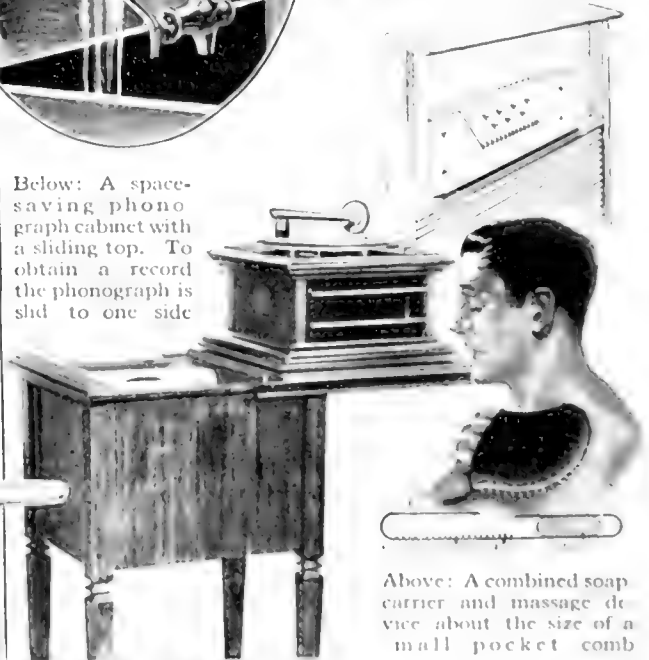

Above: A combined soap-carrier and massage device about the size of a small pocket comb

# Housekeeping Made Easy



Above: A wrist-lock for handbags which prevents loss and leaves the hand free

At right: A pencil holder attached to the telephone

Below: A heating coil is in the bulb. By pressing the bulb, hot air is forced through the teeth of the comb to dry the hair



Above: A nursing bottle-holder which slides on a rod to any desired position

Below: An egg-poacher which, when tilted, deposits the cooked eggs in a receptacle without breaking them

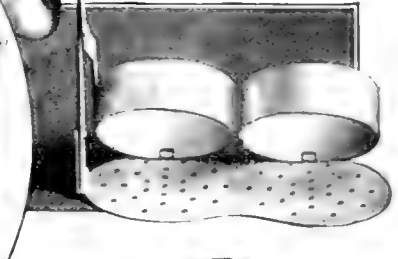
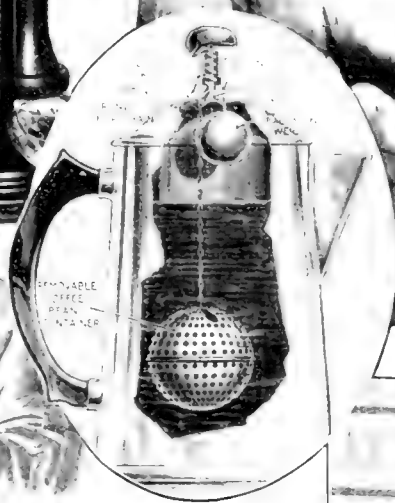

Above: A coffee or teapot with a suspended container attached to the inside of the cover

At left: A spring door-clip is slipped under the door and holds it fast

At right: A carpet beater which is operated by a crank handle connected with a spring

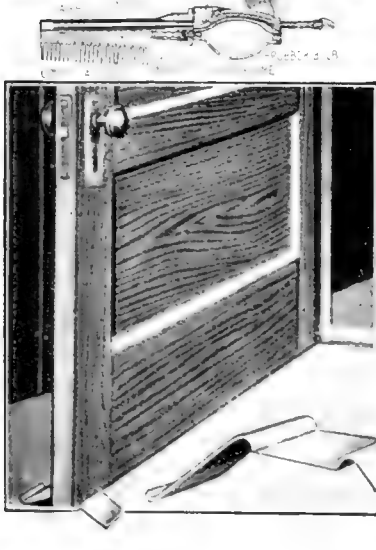



# A Dozen Ways of Breaking Your Neck

Would you care to imitate the motion of a corkscrew pulling a stopper out of a bottle? Does the idea of looping-the-loop on roller skates thrill you? Would a dash under water in an open boat make life a little less wearisome? If not, this article will reveal more monotonous killers

By George Wörts

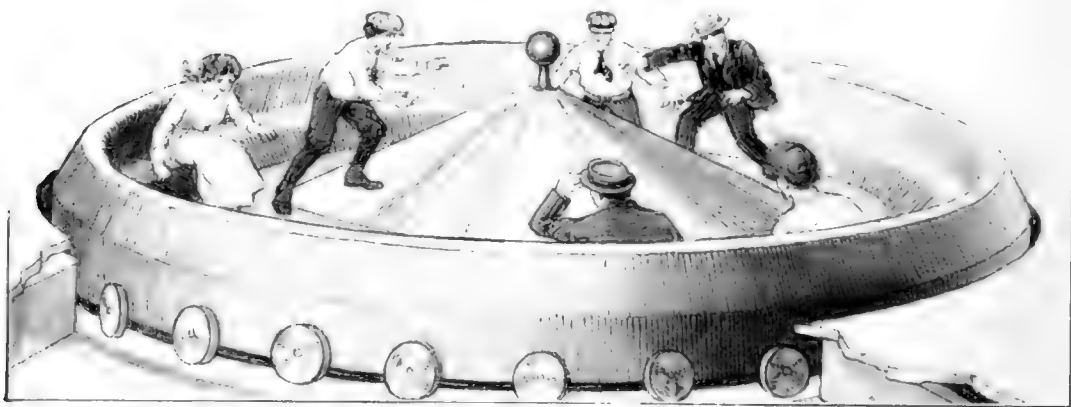

A prize is placed on the pinnacle of a polished incline in a whirling wheel, but centrifugal force deposits the aspirants on the circular seat around the edge. The incline also revolves rapidly

THE suicidal instinct must lurk deep within us. In its mildest form it displays itself when we march up to a Coney Island neck-breaker and are twisted, turned and hurled by some fiendish contrivance. The barbarian treads keen knife-blades and up-ended nails when the need of self-pain possesses him. We, who are civilized, pay a dime to have our senses of gravity and equilibrium tortured and distorted. We drop down inclines with a speed sufficient to place the pits of our stomachs on an equal footing with our ears; we spin through halls of horror, built on the architectural plan of a Belasco hell, and we bounce and hop and skid over crazy contraptions in a way that would cause our Pilgrim Fathers to throw up their hands in holy terror. In spite of it all, we like it. Nine times out of ten, we lay another dime and dash into the Hall of Horrors for a second thrill.

Back in the days of our barbaric beginnings, when we were smitten with the pangs of self-hate and we had tired of treading hot coals or up-ended spikes or set-in safety razor-blades, we consulted the medicine man, and lo!—he contrived a new and refreshing torture.

Are you tired of such mediæval tortures as the scenic railway with its stomach-

elevating swoop? Do the crash and splatter of the shoot-the-chute bore you? Thumb, then, the illuminating pages of the Patent Office Gazette, and let the medicine-man inventor decide for you. Select your neck-breaker and request your favorite amusement park man to build one.

## *The Wastebasket of Dizziness*

For example, there is a thriller which might be labeled "The Wastebasket of Dizziness" (page 862). Another good name for it is the "autowhirl." A wood or steel structure resembling a gigantic wastebasket is lined with rails set spirally. The car starts at the top, gathers momentum and whirls around and around until it shoots out at the bottom. It resembles the baskets of death so familiar to the circus or vaudeville *habitué*, in which a bicycle or motorcycle rider drives around and around until, by centrifugal force, he has attained a whirling motion parallel with the stage.

Exhibit B partakes of the merry-go-round variety of thrill (page 862). A mountain stream which apparently defies the well-known law that water runs down hill, not up, cascades merrily up and down a narrow ravine. This feature is achieved through recourse to a good plumber. It surpasses Tennyson's brook. It not only flows on

and on, but it meets itself; for it is circular. In the center of the circle a huge mast is pivoted. Six poles reach horizontally outward from the top, and at their tips cables are attached, which terminate below in the prows of six small boats. The mast revolves, and the boats are drawn on a monorail through the circular stream. To all intents and purposes this giant toy is the old merry-go-round, well disguised by mountain scenery, with something of the scenic railway thrown in for good measure.

### *Tobogganning in Summer*

Perhaps the hardihood of the people of the ice countries inspired the genius who conceived the idea of the all-year-round toboggan, which is shown on page 862. The Alpine slope is made of wood or structural steel and in place of a smooth ice surface, coco-matting is substituted. The bottom of the toboggan is polished metal, and it glides freely over the slippery nap of the coco-matting. Leaping the gap squeezes this thrill to its tenuous limit.

A Philadelphia inventor has found a way to inject a new thrill into the scenic railway (see below). Instead of continuing in a

direct course up and down and around dizzy curves, the Philadelphian proposes to reverse the direction of the car at certain shocking intervals. One moment you are hurtling through space; the next, you are suddenly spun about and fly on in the same direction, but with your back to the scenery.

Only circus performers should be permitted to indulge in the neck-breaker shown at the right of the illustration on page 863. The thrill to the amusement seeker is derived from watching. Two large concentric rings of metal comprise the vehicle, which, following circus precedent, ought to be christened "The Ring of Death." The smaller ring revolves easily within the larger one because of small oiled wheels between the two. A saddle and handle are bolted to a brace on the inner ring. When the outer ring revolves, the man on the saddle is stationary. The rider in the hoop of death rolls down a protruding incline built from the top of a tower and drops through the air—leaps the gap, that is to say—and if the ring has not toppled in its flight, strikes the incline and coasts to safety while the spectators sigh in relief.

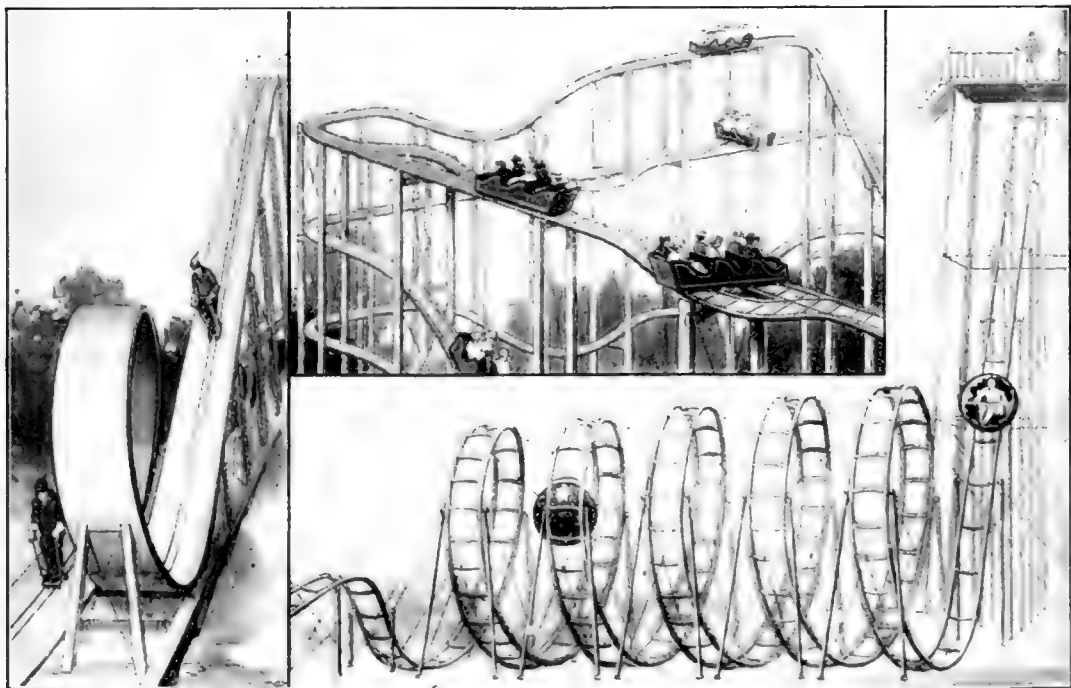

The most popular of all amusement-park devices is the scenic railway. The special thrill produced by the one shown above in the center occurs at the switches placed at intervals along the course, to whirl the car around suddenly. The device on the right is a hollow steel ball in which the occupant is hermetically sealed to whirl down an incline and over a spiral track. On the track on the left you may loop-the-loop on roller skates which cannot be pulled out of their grooves



At left: The car is carried by an elevator to the top of the basket, from whence it makes a dizzy dive down a spiral track and out upon a sharp incline:

At right: This slide is coated with slippery coco-matting in lieu of ice and has a gap near the end of the course which the toboggan jumps:

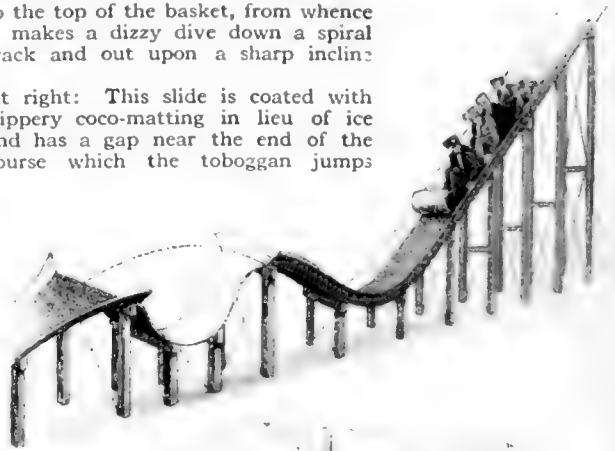

At right: Here water introduces the novelty. The central post revolves and the boat-cars follow the course of the stream over a circular monorail track:

Below: A dash under water in an open boat would be thrilling enough for the most daring if it could be made without drenching the bold adventurers:

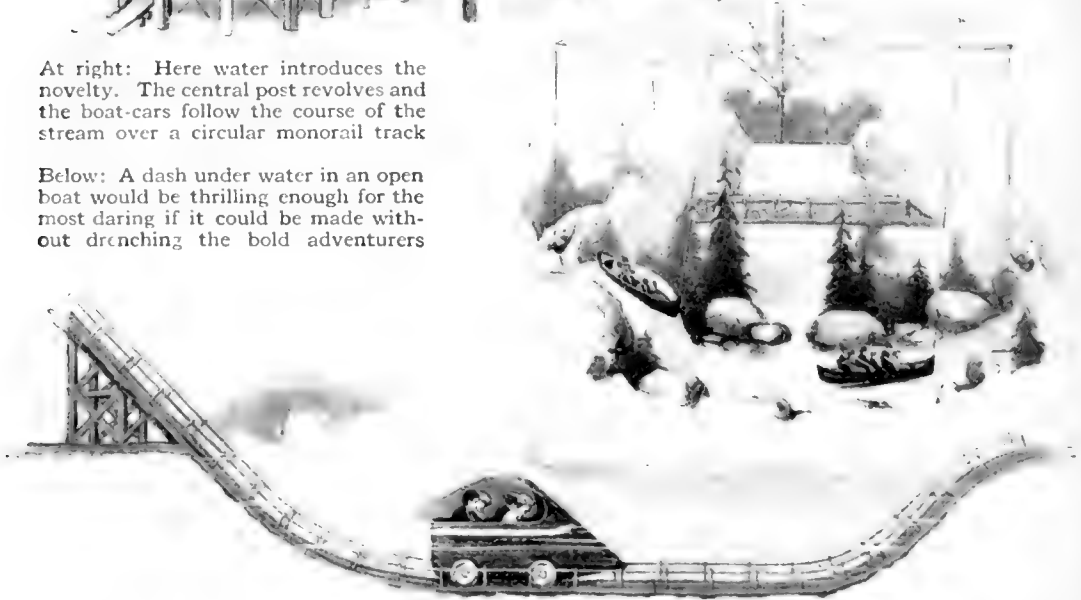

### *Commend Yourself to the Angels When You Ride in This*

All nerve specialists could afford to ride in expensive limousines if an idea hatched by a Belgian should have widespread reception. The patent claims describe the invention as an "amusement device." Called by any other name, it would centrifugally snap the head of any enemy to society from his shoulders with equal adroitness. The awful thing is shown in the central picture in the group of three on page 863. A car, of the loop-the-loop or scenic railway variety, is attached to the end of an upright steel pole which is pivoted to a steel frame of considerable height. The car revolves once, then is automatically detached from the pivoted pole; it flies through the air, describing a somersault

unassisted, finally landing upright on an incline—provided that the angels in heaven are smiling and nothing goes wrong.

Tickling the hind heel of an irascible mule would be an intelligent and cautious proceeding compared with risking one's precious neck in this machine. The final incline might well be made to terminate in the back entrance of an undertaker's establishment, to facilitate delivery.

Aside from an occasional freak such as this, improvements upon or embellishments to the scenic railways of our childhood occupy the time of most amusement inventors. A helical track, not unlike the "Wastebasket of Dizziness" mentioned previously, is the most absorbing feature of another neck-breaker. The car ascends the spiral, and a loop-the-loop is inserted

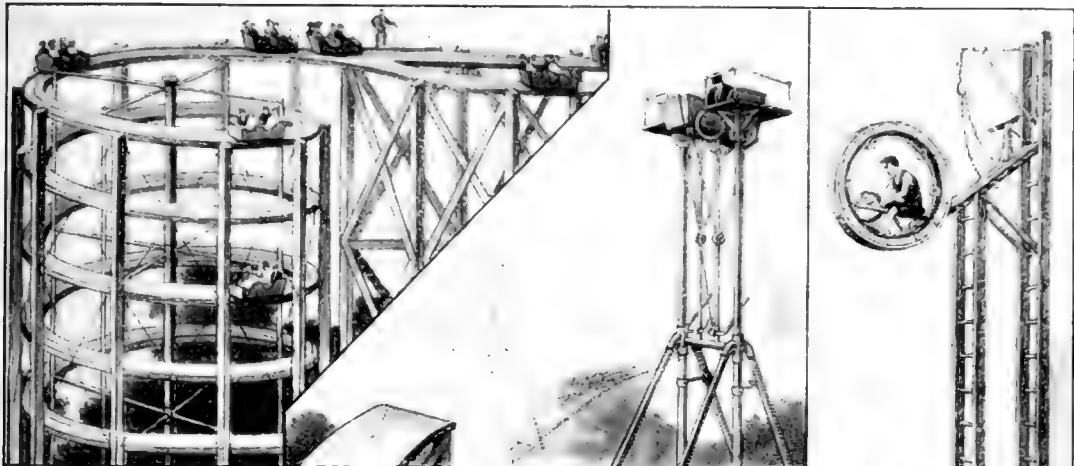

At left above: Another variation of the scenic railway in which a revolving framework in the center of the spiral track pushes the cars upward. In the contraption in the central picture the occupants are strapped in the car, which is shot out from the steel support to execute a somersault and leap to an inclined track. At the right, a saddle is bolted to a wheel which revolves within a wheel, rolling down a sharp incline and leaping to a slide below

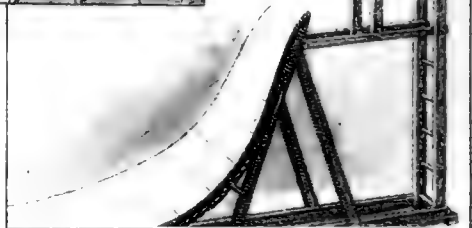

elsewhere in the track so that the mad occupants of the car will be sure of their money's worth.

Let us not forget the "Corkscrew of Fate," or whatever it may be called, which is illustrated on page 861. One enjoys the corkscrew motion after having entered a hollow steel ball and dropping in it down a precipitous incline. Centrifugal force holds the ball to the rails, and it whirls around and around in the spiral, rolling out at the end against a cushioned bumper, where the occupant emerges, a sadder and wiser, if not a broken, man.

The whirling wheels of Coney Island are reflected in a recent British patent device. Built as a horseless merry-go-round, a revolving platform offers its occupants the pleasure of climbing a steep slope to the center and seizing a prize which is placed there. Centrifugal force explains why very few aspirants could reach the box of bon-bons, solid gold watch, bouquet of flowers, pint of gasoline, or whatever the prize might be.

Fortunately, serious-minded men in amusement-park communities have the power to censor the extent to which these thrills may be carried. Yet for each life-risking device which the censors have deleted a dozen others have been brought forth. The loop-the-loop devices are no

longer popular, being too literally neck-breakers; but the amusement-park man who claims that he cannot find enough thrillers for his patrons is either lazy or lying.

#### The Medicinal and Hygienic Virtues of the Lemon

**I**F the testimony of the Sicilian Citrus Chamber is given due consideration in determining the status of a lemon, it deserves an important place in the list of first aids. According to the authority mentioned the lemon aids are chiefly medicinal and hygienic. Its juice is of value in treating diphtheria and gout. For ordinary colds it is a great specific. It will cure slight wounds and chilblains. The juice of several lemons taken every day will help to cure rheumatism and prove an antidote for diabetes; small slices applied to corns will ease the pain.

As a cleansing agent and beautifier, the reputation of the lemon soars still higher. The juice whitens the hands, improves the complexion, helps, if anything can, to remove freckles. In the culinary department it ranks with salt and sugar in general usefulness, and as a furniture polish its oil is beyond reproach.

And yet to be dubbed "a lemon" is considered uncomplimentary!

# A Floating Road for Automobiles

A plank roadway built over a California stream enables automobiles to cross under their own power



Above: Light cars pass over the semi-floating bridge at a speed of about ten miles an hour

Plan view of floating road

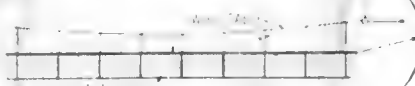

At left: The bridge plans. The supporting cable was twenty-five feet above the plank sections

**A** SEMI-FLOATING bridge, one hundred and four feet in length, has been constructed by the California Highway Commission over Castaic Creek on the recently opened Los Angeles to Bakersfield route. The ford at this point has long been a menace to automobile travel, because of the varying depth of water and the extremely sandy bottom. Teams have, therefore, been maintained at the crossing by the county to tow automobiles across. While effective, this method was very unsatisfactory.

To relieve this condition a semi-floating highway bridge was constructed. A plank road was built in sections and held together by cables in such a way that a good surface would be continuous across the ford. The depth of the water was thus decreased, not only by the thickness of the plank and stringers, but also by the amount which the tires would otherwise sink into the soft, sandy bottom.

After the sections were built on shore and floated to the crossing, they were held

together by a three-quarter-inch cable threaded through eyebolts in each section. At twelve-foot intervals the cable was attached by one-half-inch cables to a seven-eighth-inch cable stretched across twenty-five feet above the plank sections, and drawn sufficiently taut to support it four feet above high water.

One end of the bridge was securely anchored with a three quarter-inch cable clamped to the eyebolt on the last twelve-foot section, and made fast to the shore. The opposite end was lightly secured with a one-half-inch cable to the shore. This was done so that in case of high water carrying drift against the bridge, one end would be released from its anchoring point, allowing the bridge to swing around to the opposite bank.

The bridge was completed in two days at a cost of \$17.50 for labor and \$126 for material, freight and cartage. Light cars can pass over it at a speed of about ten miles an hour without submerging the different sections as they pass over.

# Faster Than the Fastest Express Train

The new Curtiss biplane makes one hundred and nineteen miles an hour

By Carl Dienstbach



On account of its moderate size and its elimination of small exposed parts this biplane has speed and climbing power

**T**HE really formidable problem of the aeroplane of to-day is cutting down the resistance of its structure.

A very meritorious solution of this problem is found in a new Curtiss biplane which has attained speed and climbing power way beyond the usual range of its allotted motor power. The accompanying picture reveals its points of difference. Raking the air by small parts is eliminated more than in any previous design. The new machine shows "smooth bulk" and properly shaped "streamline" (to use a hackneyed and often unjustified expression) from the spokeless wheels and their triangular-shaped "legs." An important exception are the few struts which as triangular frames join the upper plane at its center to the body. There is only one bracing member on each side. This is a bulky strut running from the lower to the higher plane and inclined so as to be compression and tension member in one. Additional bracing is supplied by a similar but even more inclined strut running to the wheel-base. Hence the biplane is stayed like a monoplane, and the design becomes very strong.

As the wheeled base must in any case form a strong downward projection, it should be made thus to serve as a support for the wings and be thereby braced in

turn against side strains in bad landings. All vibrating wires may be eliminated in this way, and hence an immense amount of head resistance. The new bulky bracing members do not vibrate. Their number and smooth shape permit the air to flow off easily on all sides without being caught by many adjoining wires and other exposed details, as by a rake. The flaring of the main braces at their ends is necessary to distribute their support over the depth of the ribs. There is one more improvement. A circular hood which revolves with the propeller is placed in front of the radiator. It is open so as to draw in cooling air, but is so designed as to cut down resistance.

The machine offers a very satisfactory solution of the "unsurmountable" problem of carrying much sorely needed wing-surface on an extremely fast racing machine. Former "racers" were the poorest climbers and very dangerous in starting and landing on account of dependence on unduly reduced wing-area for speed. But the new Curtiss racer is useful all around. Its splendid performance—one hundred and nineteen miles an hour—is entirely due to its moderate size. Large machines, on account of inherent relative weakness, are hopelessly dependent on wirebracing.

# Taking the Temperature of a Dam

Forty-seven thermometers are buried in the concrete of the Kensico dam

By Herbert Francis Sherwood



The thermometers are buried at predetermined levels and points in the dam and are connected by buried cables with switchboards at central points

ONE day, a year ago, I paid my first visit to the great Kensico dam, three miles north of White Plains, N. Y., counted among the notable dams of the world. It is intended to form a storage reservoir in the Catskill system of water supply which New York city is constructing at an expenditure of \$177,000,000. The lake of Catskill water behind it will be approximately four and a half miles in length. It will have a maximum depth of one hundred and fifty-five feet, and contain upwards of thirty billion gallons of water.

It was a bleak day. The thermometer early in the morning had registered zero. A searching northwest wind swept down through the whole length of the great basin in the Bronx valley and chilled to the marrow those who went out upon the crest of the dam. Accompanied by the division engineer, I descended from this exposed place to the long corridor extending for more than a third of a mile through the dam. This corridor was open to the sky at intervals and I was astonished at the warmth of the air encountered there.



"This part of the dam has only recently been laid," said the engineer, "and the heat, generated chemically by the cement in the concrete as it solidified, has not passed off yet."

Then he explained that concrete expands and contracts, after the fashion of steel, and that the dam had been built in sections about seventy-nine feet long, interlocking from the bottom to the top. Observation of other Cyclopean structures of masonry had revealed the fact that in the course of expansion and contraction cracks appeared about seventy-nine feet apart. So it had been decided to provide in this way for expansion-joints in the dam.

As little was known of the changes of temperature which occurred in a large mass of concrete and as this information might be of value in designing other structures of similar character, it was determined when the Kensico dam was built that its temperature should be taken regularly at different points between the base which is one hundred and fifty feet below the surface of the ground and the top, approximately the same distance above it. This has now been done for a period of more than two years, an electric thermometer being used for the purpose.

A thermophone is a device which will measure by means of an electric circuit the temperature at any point connected with it by wires. Its principle is that of the well-known Wheatstone bridge by which resist-

ances can be measured. The cable which leads from the recording apparatus and the dry batteries to the sensitive resistance coils where the temperature is to be taken carries three insulated wires. Through one of them the current passes to the sensitive terminal, where it is divided and returned through two minute coils of copper and German silver wire. These metals are affected differently by changes in temperature. These changes affect differently the freedom with which a current of electricity will pass through them, and this difference indicate what the temperature is.

Forty-seven thermometers were buried in the dam, the lowest being below the foundation. They were connected with switchboards placed at central points, the cables, carefully protected, being buried in the masonry as it rose. There are three switchboards, the lowest being stationed in a nook in the long inspection-gallery.

### Will the Great Sphinx Scowl When She Sees This?

**I**N seeing America first one should not overlook the Sphinx built at Blue Point, Long Island, by William Graham. This domestic Sphinx is just one seventh the size of the original great Sphinx in Egypt, and it is just as mute. It weighs forty-two tons.

The idea of decorating his front yard with a copy of Egypt's great attraction came to Mr. Graham when he was

removing a large quantity of sand from his lawn. Instead of carting the sand away, as he had done in past years, he collected it in a huge pile, and then drew up plans for his Sphinx. The sand was mixed with concrete and iron scrap.

The head of Mr. Graham's Sphinx is solid, weighing ten tons. The lower part of the image has a circular chamber with an opening at the rear. Seats and pillars of concrete extend around its inner walls.



The head of the Sphinx weighs ten tons. The lower part of the image is a room with an opening at the rear



### Laying a Brilliant Trail for Bargain Hunters



Broad stripes of brilliant red painted in water-color on the cement sidewalk converge at the show window and point out bargains

A CLEVER Los Angeles shop-dealer drew many passers-by to his show-window by a simple device which cost him only a few cents and a few minutes' work. He utilized the cement sidewalk in front of his store as part of his advertising medium, painting broad stripes of brilliant red on the pavement and spreading them out in all directions. They all converged, however, upon the show-window.

The scarlet stripes were carried up on the plate-glass, and behind the pane each stripe was continued further by a strip of red paper which led to some article in the window marked at a bargain price. The paint used was water color and could be readily washed off when it had served its purpose. Hardly a person passed without having the attention attracted by the lines on the pavement and stopping to investigate their meaning.

### Separating the Rooster from His Crow

THE latest fashion news from the poultry yard describes a new style of nightcap for the rooster. Of course the rooster is not consulted as to whether he likes it or not, but he wears

it under the mandate of the poultryman, who in turn is influenced by the more or less caustic remarks of his neighbors. For while wearing the nightcap the rooster is

separated from his crow. No longer can he perform his natural duty of signaling to the immediate poultry population.

The cap is made of strong canvas and has suspender straps which fasten around the legs and hold the cap in place. These hang comfortably loose when the rooster's head is down, as when he is eating; but when he attempts to throw his head back and his chest out in order to give vent to his pride in a crow that may be heard by every rival cock for miles around, he finds himself unreasonably restricted. The cap muzzle may be worn during the day, also, if necessary.

### The "Step Lively, Please!" of Stage-Coach Times

WHEN the traveler's blood is boiling with resentment against the autocrats in uniform who issue peremptory commands and hustle belated passengers with scant courtesy into overcrowded cars, he is apt to inveigh against modern times and sigh for the days in which, although travel was slow, a man had at least time to catch his breath. But F. G. Marchand, a Canadian writer, in a graphic description of a stage-coach journey in the seventeenth century, shows that although conditions may change, the conductors of to-day and those of olden times are of one clan.

The special grievance of the stage-coach passengers was not so much the overcrowding, although the wooden horse of Troy could not have been more closely packed.

It was the heartlessness of the conductor at the times and places allotted for eating, that finally caused a general strike of the patrons. He was accused of being in connivance with the inn-keepers, who invariably had a tempting *table d'hôte* ready on the arrival of the coach. But scarcely had the hungry travelers attacked the first

course when "All aboard!" was shouted. The driver mounted his seat, cracked his whip, and the passengers either scrambled ignominiously aboard or were left behind.



The cap is made of strong canvas with suspenders fastening around the rooster's legs

# The Intelligent Motor Milk-Wagon

Like the milkman's trained horse it ambles mechanically on while deliveries are made from door to door

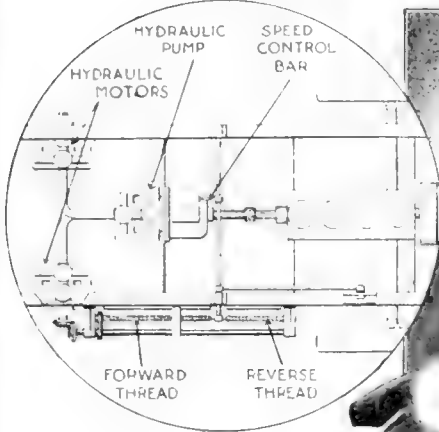

A half-nut enmeshes with the threaded-shaft and is moved by it when the wagon is running. The farther to the left it is placed the longer it will take it to move the control-lever and stop the car

**A**T LAST the intelligence of a milkman's or baker's horse in moving from house to house during deliveries has been duplicated by a device applicable to any type of motor vehicle. It consists of a mechanism which may be set to bring the vehicle automatically to a stop at any desired distance from its position.

The operator of a truck fitted with the new device may fill his crate with enough loaves of bread or bottles of milk to supply a block or row of houses and set the control mechanism to run the truck to the end of the row while he goes from house to house.

The mechanism, the work of C. M. Manly, the inventor of the Manly hydraulic drive for motor-trucks, is shown in the accompanying sketches applied to a vehicle with that type of drive, although by suitable attachment to the clutch and brake-operating pedals it may be fitted to trucks with ordinary spur-gear transmissions that have shifting control members.

The device consists of two parallel shafts mounted on brackets on one side of the truck frame, forward of the jackshaft, as shown in the accompanying illustration. The outer of the two shafts, driven by means of a bevel-gear at its rear, which

meshes with another on the extreme end of the jackshaft, drives the inner shaft through a pair of spur-gears. The outer shaft carries loosely a half-nut, the threaded portions of which engage the threads on the inner shaft. The nut can also be disengaged from the shafts and stored away when the driver is running the car from the seat. In its course along the threaded portions of the inner shaft the half-nut comes into contact with a vertical arm of the vehicle which is connected with the speed-control bar attached to the hydraulic pump through a shaft crosswise.

In operation, the driver sets the half-nut on the rearmost of the threaded portions of the inner shaft, according to graduations marked on the outer shaft. He then moves the vertical hand-control lever forward a short distance to start the truck at slow speed. Then as the vehicle moves forward, the inner shaft is revolved and with it the half-nut is moved forward until it comes in contact with the control-lever, at which time the nut moves this vertical lever on the crosswise control-shaft to its middle position, and causes the vehicle to stop.

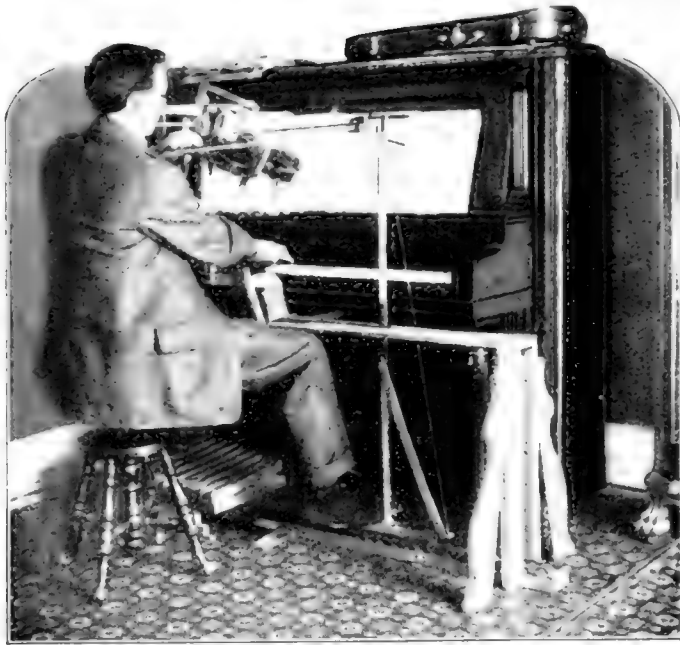

Mayor Harry L. Suter playing the violin and the piano at the same time and making satisfactory music, at that

### The Mayor of Moscow, Ohio, Is the Town's One-Man Orchestra

**I**N addition to directing the political destiny of Moscow, Ohio, Mayor Harry L. Suter is the town's one-man orchestra. He has devised an apparatus which makes it possible for him to play the piano and violin simultaneously. It takes both of Mayor Suter's hands, as well as his elbows, feet, and eyes to keep the two instruments going in the same musical time, but the results are worthy of his efforts, when one considers that he is an orchestra all by himself.

When the two instruments are under the spell of the Mayor, the right hand plays the solo part while the bass part of the piano is operated by the left foot coming in contact with a series of pedals similar to those of an organ. The violin bow is held on a small standard which moves along a groove. A double vise holds the violin, and the part through which Mayor Suter passes his left arm controls the violin, so that the proper string will rest against the bow. The bow is controlled by the right foot, while the fingers of the left hand press the strings. The elbow operates the "loud pedal"

### Air-Jet Supports a Football in Mid-Air

**T**HE photograph below shows a football suspended in mid-air by an air-jet having a velocity of one hundred and twenty miles an hour. Suspended below the football, and attached to it by light wires is a plate which by its pull offers still further resistance to the air current.

This exhibition of the supporting power of an air-jet was given in Agricultural Hall, London, and the fan used was an ordinary centrifugal high-pressure blower with a six-inch diameter outlet at the extreme end of the nozzle.

The phenomenon is explained in the following manner: The jet issuing from the nozzle spread out into a cone-shaped formation on being released, and the ball was held in the center of this cone. The high-pressure jet acting upon the surface of the ball, caused a slight upward reaction which tended to maintain the ball in the air.

It will be seen that the ball is in the center of the jet and not on the edge of it. This is in contradistinction to the theory that the object is suspended by contact with the outer strata of air in the jet. The ball is held almost perfectly at rest in the air-current.

The ball is held suspended in the center of a cone-shaped air-current

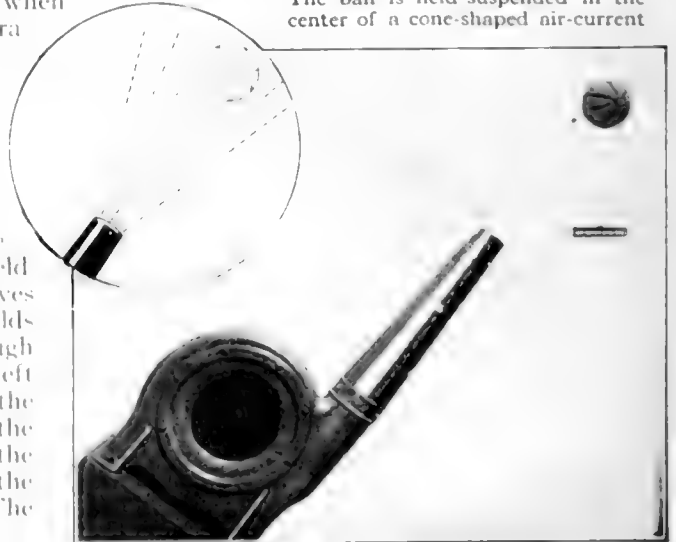

How Man's Eyes Differ from Those of the Animals

ASIDE from the monkey, man is the only animal having what we call binocular single vision. That is, he can tell not only the direction of an object, but he can estimate fairly accurately its distance. This is because both of his eyes point at the same object at the same time, like two range finders. Other animals do not concentrate their gaze in this way. Their eyes are set more nearly at the sides of the head so that they see not only forward but backward for a short distance. Man, on the contrary, sees clearly only the object at which he looks directly.

Using a Tree as a Mast for a Wireless Station

THE ceiba tree is the largest specimen of the vegetable kingdom growing in Central America. The city of La Ceiba, chief among the settlements on the Caribbean coast of Central America, was given its name because a huge ceiba tree standing near the beach was a landmark for mariners.

Another of these huge trees was made use of when the big fruit company operating at La Ceiba built its wireless station. One tower one hundred and fifty feet high was constructed of steel, but the company utilized the trunk of the ceiba tree for the other tower.

The trunk as it is shown in the photograph is about one hundred feet high. A steel mast carries the wires up fifty feet further. At the buttressed base of the ceiba are shown two cottages, and a tree which, but for the presence of its giant neighbor, would be recognized as a tree of respectable size; but by contrast it looks like a mere bush or leafy shrub.

The trunk of the tree is one hundred feet high. A mast carries the wires higher

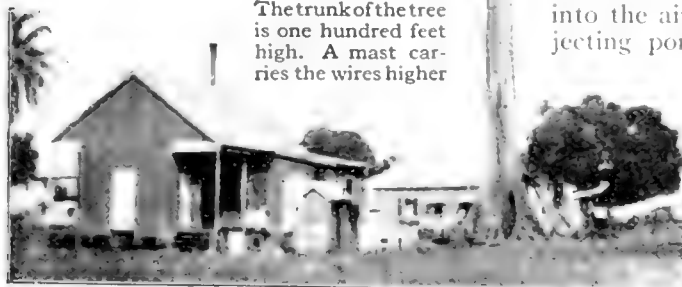

During an earthquake masonry is shaken off like dust from steeples

How Earthquakes and Similar Disturbances Change the Styles in Architecture

IT has always been a matter of conjecture why people will return to a locality which has been demolished by an earthquake and rebuild the city time and time again, apparently forgetting the disaster as soon as the debris is cleared away.

Seemingly the principal effect that an earthquake has on a region is to change the style of the architecture. Houses thereafter are made more squat and solid, and those that must have portions extending into the air reduce the weight of the projecting portions to a minimum. In the

accompanying illustration, which is a photograph taken in Fort de France, Martinique, the church spire looks as though it had been left unfinished; but such is not the case. Its openwork construction is the approved style for steeples there.

# Twelve Cylinders or Six in One Car

A mere twist of the wrist makes the change

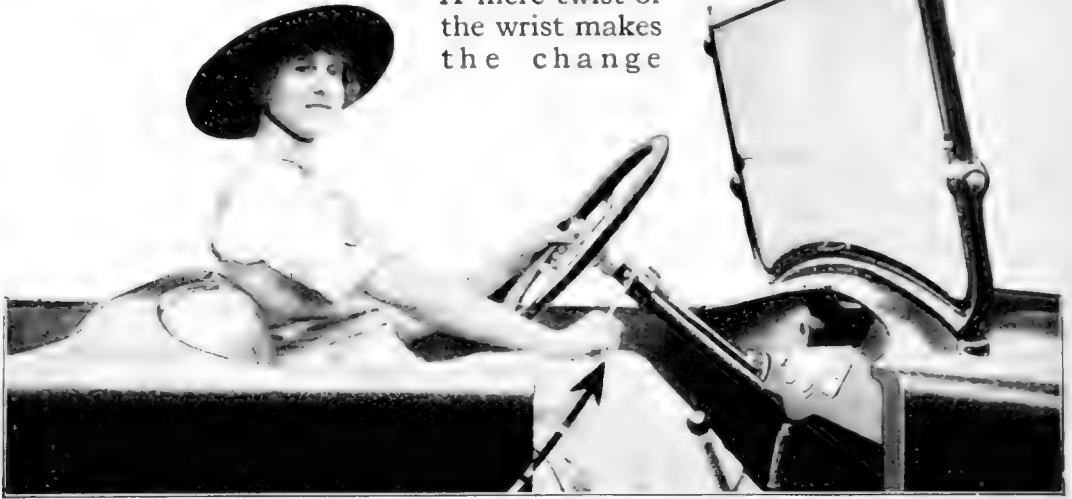

The transformation from a twelve to a six-cylinder automobile is accomplished simply by turning a lever carried under the steering-wheel. This cuts out the left-hand block of six cylinders

THE latest thing in automobiles is a car with a twelve-cylinder motor which can be changed to a six by the mere twist of the wrist. While it gives great power for quick acceleration and for hill climbing and flexible control on high gear, the twelve-cylinder motor is nevertheless a large consumer of gasoline and therefore expensive to operate. While the power of the twelve is advantageous under some conditions, the bulk of the driving of the ordinary car is done under conditions that could be equally as well done with a six as with a twelve-cylinder motor, and at a lesser consumption of gasoline. To meet these conditions, a Cincinnati automobile manufacturer has brought out a twelve-cylinder car which can be changed to a six at will, simply by turning a lever carried under the steering-wheel.

This transformation is secured by cutting out the left-hand block of six cylinders. The cut-out is in turn accomplished by means of a camshaft placed over the exhaust-valve rocker-arms. At the rear end of this shaft is a ball-and-socket joint connecting it with a shaft attached to the steering column and carrying at its upper end the operator's lever. The movement of this lever revolves the camshaft and presses the cams down upon the rocker-arms of the exhaust-valves and holds the valves open, so that there is no compression

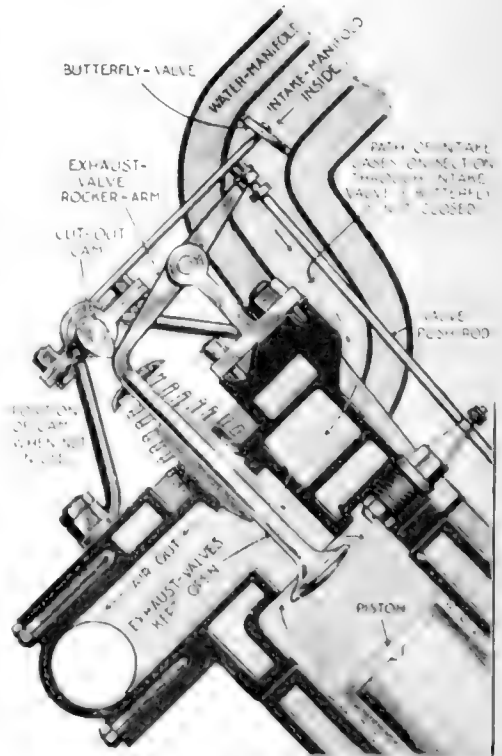

With the turning of the lever a butterfly valve in the left intake-manifold is closed so that no gas reaches the cut-out cylinders

in the six left-hand cylinders. The same movement of the lever also closes a butterfly-valve in the left intake-manifold as shown in the illustrations, so that no gas reaches the six left cylinders. All the reciprocating parts of the latter continue to operate regularly except that there is no compression or explosions, due to the fact that the exhaust valves are open and no gas can reach the cylinders. Under these conditions the motor operates as a six-cylinder type except that it has to carry the slight additional load of reciprocating the moving parts of the cut-out cylinders.

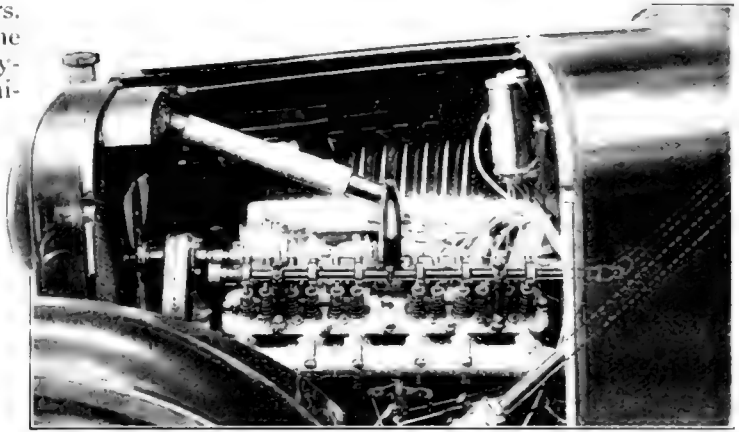

With the left six cylinders cut out all the other parts operate as usual except that the exhaust valves remain wide open

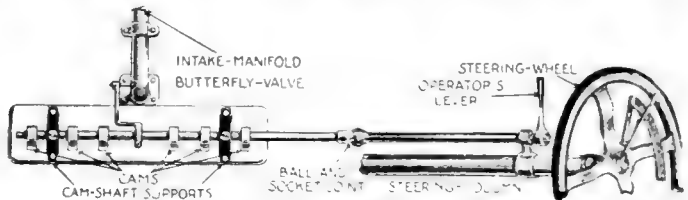

At the rear end of a camshaft a ball-and-socket joint connects with a shaft that leads to the operating lever

### The Cancer Problem and How Modern Science Is Attacking It

THE man in the street generally thinks of cancer as a hopelessly incurable disease which has attacked many of his friends and relatives and, like death itself, is too unpleasant to talk about. It rarely occurs to him that he may be the next victim, nor does he realize that if he is over forty years old there is one chance in fourteen that he will die of this disease, and as regards his wife, if of equal age, one chance in only eight. Yet if he stopped to consider what these figures mean he would perhaps decide that an ostrich policy of hiding from the unpleasant facts of life is in this case, as always, a serious mistake. Not, however, that he should lie awake nights worrying about the matter. An accurate idea of the frequency of cancer should merely stimulate a person of healthy intelligence to learn how to avoid the disease and how to prevent a fatal result if, in spite of all precautions, it should afflict him or a member of his family. Starting out on such an inquiry he would soon find that he was right in thinking cancer a common disease but wrong in believing it to be an unavoidable and incurable ailment.

Cancer is indeed more common than most people realize. In 1914 there were 54,420 deaths from all forms of cancer in

the United States Registration Area, which comprises about 60% of the population of the country. If the same rate of fatality prevailed in the states and cities outside the Registration Area, over 80,000 persons in the continental United States must have succumbed to this malignant disease during that year. In his recently published book "The Mortality from Cancer Throughout the World," Frederick L. Hoffman estimates that during the ten years ending with 1913 there were 658,139 deaths from cancer in the United States, and that the total of deaths from this disease in all civilized countries is not less than 500,000 annually.

From the annual reports of the Census Bureau, it is seen that cancer ranks fifth among the leading causes of death at all ages and that only tuberculosis, heart diseases, pneumonia, and kidney diseases take a greater toll of life. Considering only deaths that occur after thirty years of age, cancer presents an even more serious aspect. It is indeed primarily a disease of adult life, the average of death being 59 years as compared with 36 in the case of tuberculosis. In the United States Registration Area 83% of all deaths from cancer, during the years 1906-1910 inclusive, occurred at ages of forty-five and over.



### Overcoming the City Boy's Fear of Snakes

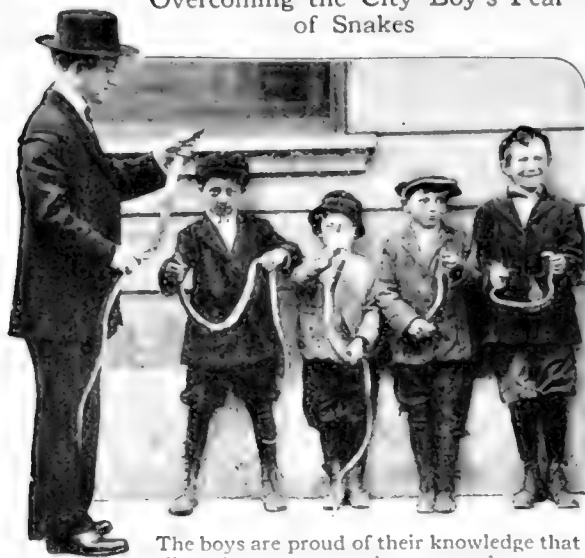

The boys are proud of their knowledge that all snakes are not poisonous or dangerous

EVER since the old days in the Garden of Eden, when the first snake played its mean trick on human nature, man has been suspicious and even afraid of the whole writhing genus. But not all snakes are enemies to man. The farmer has found that many kinds of them are his friends. Superintendent Charles H. Woodhall, of the Boys' Club of Troy, New York, has started a collection of the harmless species and is making a big success of it. His boys, most of them street urchins, are very enthusiastic over the snakes. Mr. Woodhall specializes in work for boys. He takes long "hikes" with the lads into the country, and leads them to observe everything in outdoor life. He soon saw that the average boy is mortally afraid of snakes. The city boys, who tried to kill every snake, saw Mr. Woodhall catch the creatures in his hands, and explain their wonderful structure. At first the youngsters would run away in fright, but when they saw that the snakes were harmless, they, too, learned to handle them. The snakes were then taken to the Boys' Club, to form the collection of living specimens.

The lads became fascinated with this study of nature and living things, and explained the wonders of snake-life to other boys. The boys are proud of their knowledge of the reptile, and are helping spread the news that snakes are the friends of the farmer, for they devour such pests as young rats, moles, and other grain-destroying creatures.

### Now What Would You Call This New Musical Instrument?

HEDLEY WATTY, of Groton, Connecticut, has invented a puzzling musical instrument. On first examination it looks like a violin. But then it has a horn attached to its lower extremity. What is it? The lines of the instrument above the horn part are not at all in keeping with the construction of the violin. There is a long finger-board provided with frets, but there is only one string. The number of frets, however, is supposed to give as many different tones to the one string as would be obtained from the four strings of the violin.

The specific use of the horn is to magnify the vibrations of the string. The horn is of aluminum. The transmission-bar, which has one of its ends connected with a diaphragm at the base of the horn, has its other end in direct communication with the string, thus serving as a bridge.

The musical tones are not exactly similar to those of the violin. Neither are they the tones of the mandolin, guitar or any other stringed instrument. They are emitted through the horn, which gives them a distinctly different quality.



With one string and an extra-long finger-board provided with numerous frets it produces as great a variety of musical tones as does the violin

**"Great Fleas Have Little Fleas Upon Their Backs to Bite 'Em"**

active, running sidewise and backwards and gyrating in curious and amusing ways. It

**T**O the naturalist or to any one accustomed to observe Nature closely, the fact is apparent that the problems of existence are proportionately the same in every form or stratum of life. Even the common housefly, which seemingly has nothing else to do but to crawl lazily over whatever is left uncovered and then go happily on its way, doing its best to bring about an affiliation between the clean and the unclean, occasionally meets its Nemesis in the form of a tiny crab-like creature which attaches itself to the fly's legs.

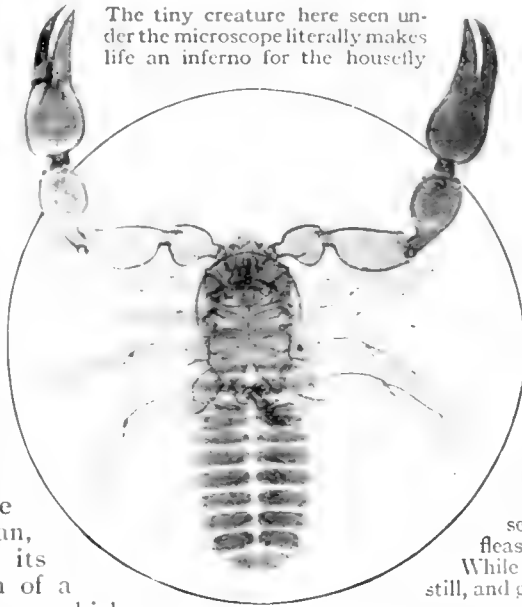

The tiny creature here seen under the microscope literally makes life an inferno for the housefly

is easy to imagine the annoyance it causes the fly, when one or more of the pests decide to join hands with it; for whatever other activities the chelifer may find it never loses its hold of what is to be its storehouse of food eventually.

For, as De Morgan says:

"Great fleas have little fleas upon their backs to bite 'em;

And little fleas have lesser fleas, and so ad infinitum.

And the great fleas themselves, in turn, have greater fleas to go on;

While these again, have greater still, and greater still, and so on."

These little creatures are known to the scientist as pseudo-scorpions, or chelifers. They may sometimes be found between the leaves of old books that have stood unused for a long time, and also beneath the bark of trees and in mosses.

Although they are called false scorpions they resemble the true scorpions closely in general structure except for their minute size. But they have no poison gland as the true scorpions have. They attach themselves to other insects also, but they seem to be the special pest of the houseflies. Scientists suppose that they seize the fly's leg and hold on until the fly dies, either worried or frightened to death by the undesirable presence. When the fly is dead the little creature feeds on the body.

It is interesting to watch them under the microscope. A simple hand-lens will show them up to advantage. They are extremely

**Iridescent Fish-Eggs for Table Decoration**

**P**ERSONS living on the Atlantic coast, or visiting there during the summer, often wonder at the beauty of the various "berries" on seaweeds. Many a lover of the seashore, and of the beautiful, has gathered large quantities of these variegated objects. They are beautiful when artistically arranged in a glass receptacle so as to display the various colors, but they are not the fruit of a marine plant.

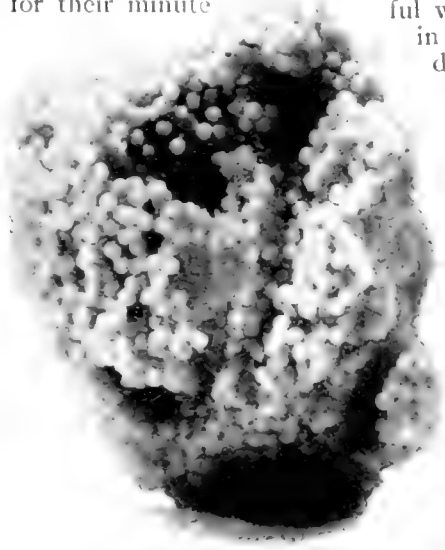

The eggs of the eighteen-spine sculpin arranged in a large jardiniere for decorative purposes

On the contrary they are the eggs of the eighteen-spine sculpin and of other allied varieties of sculpins, and they furnish an excellent example of the astonishing profusion of material with which nature works along certain lines in the propagation of species. She seems to realize that many fish are fond of these eggs and she intends that there shall be no diminution in the number of sculpins. She acts accordingly.

# Mechanical Helps Which Fit You to Your

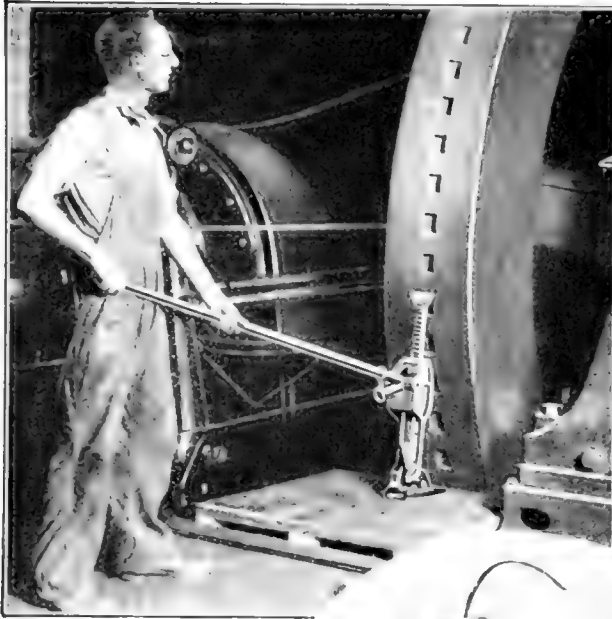

Above: A jack which turns a giant flywheel off the dead center

Below: A tool tray which, when reversed, becomes a smooth table top

Below: An electric vibrator attached to a pattern-plate to take the place of hand rapping

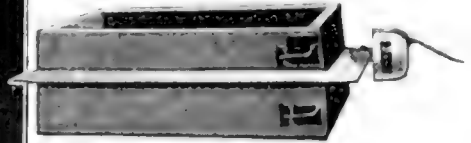

Above: A transparent changeable sign with celluloid letters which are set in grooves in the plate-glass sheet

Below: A safety-first oil-can with a six or eight-foot spout. A thumb pump forces the oil where desired

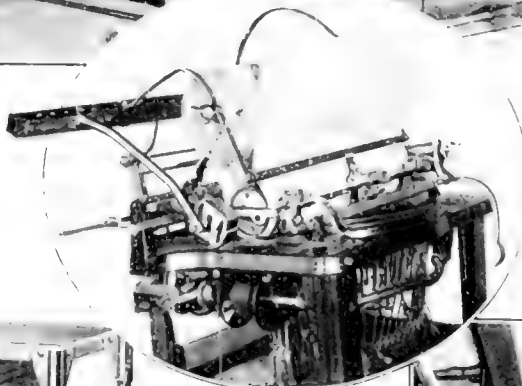

Above: A roll of typewriter paper used to write a letter of any length. A sharp knife cuts the paper off where desired



Below: A timekeeper device in which the clock strikes the time to be recorded on the phonograph-cylinder. You give your name through the horn

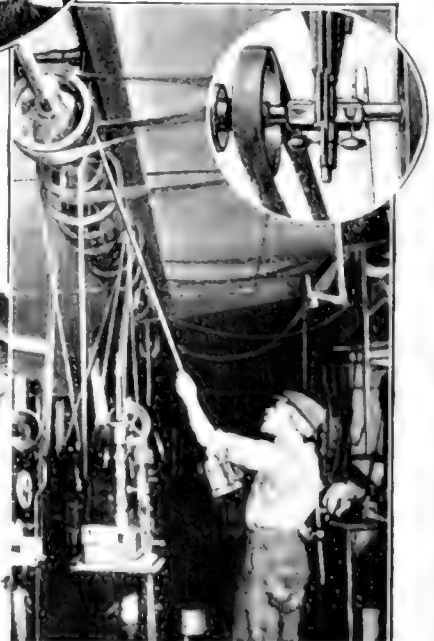
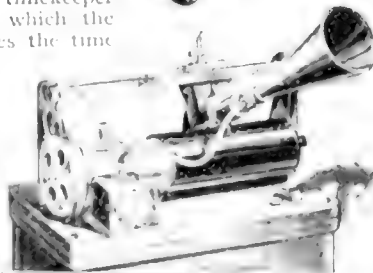

# Job, and Save Time, Money and Effort

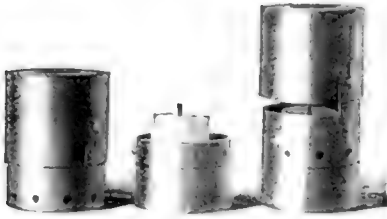

Above: A soldering lamp for telephone linemen. Heat is supplied by a candle

At right: A protected fuse board. Each fuse has its marble slab partition

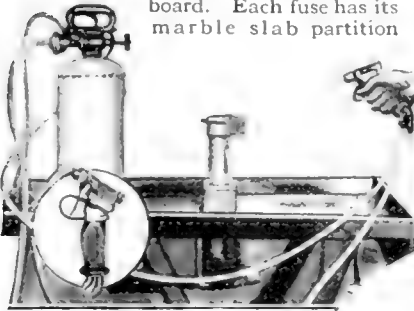
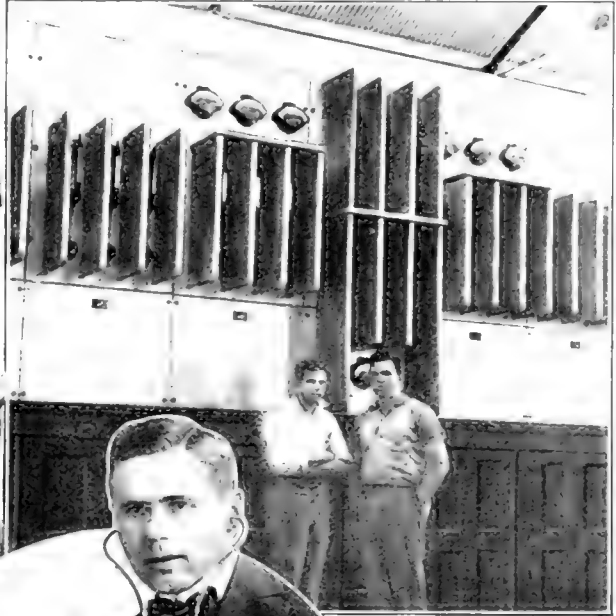

Above: A portable paint gun. Both paint and air are fed to the gun at constant pressure

Below: A window-cleaning chair of solid steel, with a firmly-clamped seat of heavy wood



Below: A typesetting-machine copy-stool to take the place of the usual dilapidated chair



Above: Hearing the telephone call with both ears by the aid of an ingenious ear-plug device. Your hands are free to write



Below: A filing cabinet with folder suspended by cloth pockets on metal bearings

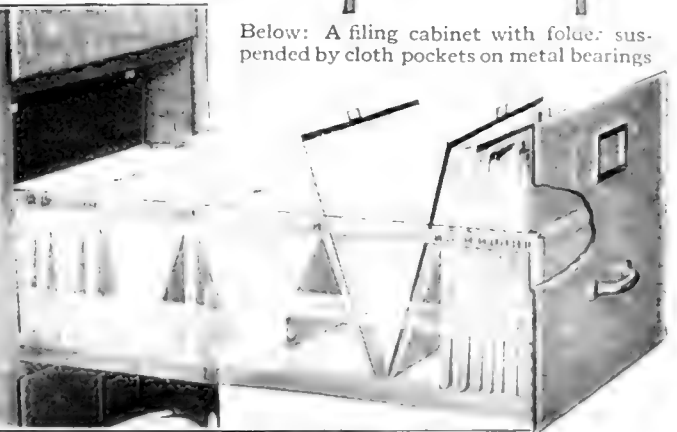

# Ax-Handles Made to Order

The boss chopper wants his ax-handles made to suit him



The wood must be straight-grained, free from knots and other defects



Roughly shaping the green handle

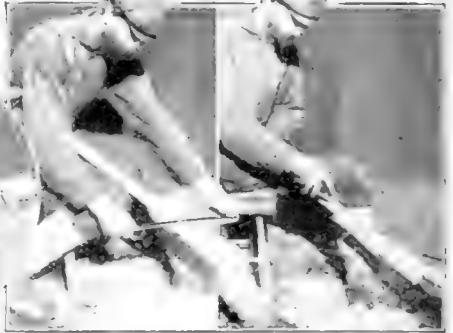

Making the opposite faces of the ax handles as nearly parallel as possible

**A**LTHOUGH nearly all ax-handles are machine turned there is still a local demand in logging camps for the hand-made product. The boss choppers and sled-tenders are exacting in their requirements and provide a good business for the professional helve-maker who caters to their particular needs and whims.

Choppers generally use an ax with two edges or bits, one edge for clear chopping and the other for chopping knotty places where there is liability of striking the ground. The handle for a double-bitted ax is straight and has a "nub" at one end to prevent it slipping out of the grasp. Though simple in design, the making and fitting of such a handle requires considerable skill.

There is a knack in the choice of tree for ax handles. The wood must be straight-grained, free from knots and other defects, and naturally tough and strong. Medium-sized, thrifty trees are preferred; and usually only the butt-cut of some thirty-four inches in length is taken, as the remainder of the tree does not possess the inherent strength and resilience that years of resistance to the swaying action of the wind has imparted to the portion nearest the ground.

This bolt is quartered, and from each piece the heart is split off, leaving no trace to mar the clear whiteness of the sapwood. If a quarter is large enough for more than one handle it is divided accord-

ingly. The bark is then hewed off and the piece flattened and roughly shaped. The final hewing leaves the handle blank "eight square," though strictly speaking, the cross-section of the handle at this stage is a flattened octagon.

The eight-squared blanks are taken to the shop, where all hewing irregularities are smoothed off with the draw-shave. This is followed by a small plane which makes the opposite faces as nearly parallel as possible. Two knobs are then left on the ends of the blank, one to form the nub and the other to form the part that fits into the eye of the ax. In reducing these to the desired shape the maker uses a crooked knife specially designed for cutting curves in wood. He holds the handle in his lap and shapes the nub. This portion is made larger for winter use when the chopper's hands are mittened.



Finishing off the green handle and polishing it

When the nub is finished the rest of the handle is shaved down, the work being done from each end toward the middle. Some prefer that the lower grip of the handle be decidedly flattened, while others insist upon a more rounded form.

Choppers do not want their handles seasoned, as the drying makes the wood more brittle and reduces the flexibility. In

order that the green handles may be properly smoothed, however, they are superficially dried on wires over the stove. They are then rasped and sandpapered.

# Eyes Were Made to See With

Do you know how to use yours? Read this article and then test them with the picture

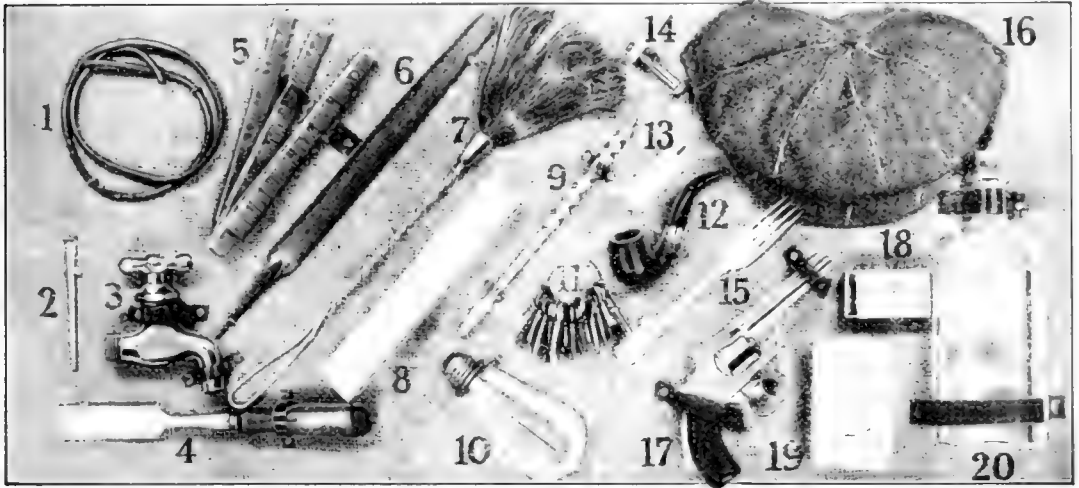

1—Wire  
2—Nail  
3—Faucet  
4—Chisel  
5—Rule

6—File  
7—Fly Swatter  
8—Block of Wood  
9—Bit  
10—Incandescent Lamp

11—Keys  
12—Pipe  
13—Candle  
14—Bolt and Nut  
15—Fork

16—Cap  
17—Revolver  
18—Match-Box  
19—Soap  
20—Bottle

ONE of the fundamentals of life, to which comparatively little attention has been given, is the ability to see straight. Very few of us see what is placed before us or what goes on under our very noses. Fortunately this faculty of observing correctly may be improved by practice, but first we must be made to realize that we are deficient in it. To prove this to classes of young engineers, Mr. W. H. Blood, Jr., performs a very simple experiment.

He has found it interesting to test his classes to see how far they have cultivated their powers of observation. On a board are mounted twenty objects, ten of them being ordinary household articles and ten of them simple mechanical or electrical objects. This is reproduced in the accompanying photograph. The numbers are not on the board itself but are used in the illustration for the sake of identification. The board is displayed before the class and the observers are allowed to look at it for a predetermined time; then the exhibit is covered and they are asked to write down the articles which they have seen. While this test in psychology does not prove much of anything, an analysis of the answers obtained

certainly does give us food for thought.

A recent experiment of this kind, tried on a large group of technical students, gave some startling results. Here was a group of educated young men who for half a minute gazed intently at these twenty articles. Several saw only three or four of the articles; the average for an entire class was but eight. What was the matter with these boys? Half awake, you say? Oh no, they were all wide awake, none more so. The test simply shows that these students have not been taught to observe. How can they make clear deductions if they are unable to tell what they have seen? Some of the men said the color of the burlap which covered the board was white, while others said it was black, yellow; only few said it was brown or buff. A curious fact brought out by this test was that nine out of ten put down on their list articles which were not on the board at all; they drew on their imaginations, but their guesses were not right. Of this entire class the best observer had but fourteen out of the twenty correct,—equivalent to 70 per cent; the average was 40 per cent, and the poorest was 15 per cent correct. A pretty poor showing for a group of technical men.

# She Lies on Her Side—But They'll Raise Her

The "Washingtonian" foundered in ninety feet of water. They are floating her with compressed air

OUR present-day salvors, who no longer hesitate to attack with undaunted spirit sunken ships which have been given up as hopeless, will watch with interest the bringing of the

26, 1916, the *Washingtonian* sank in ninety feet of water. Loaded to her full capacity with raw sugar brought from the Hawaiian Islands for Philadelphia, she sank in ten minutes. The sugar ab-

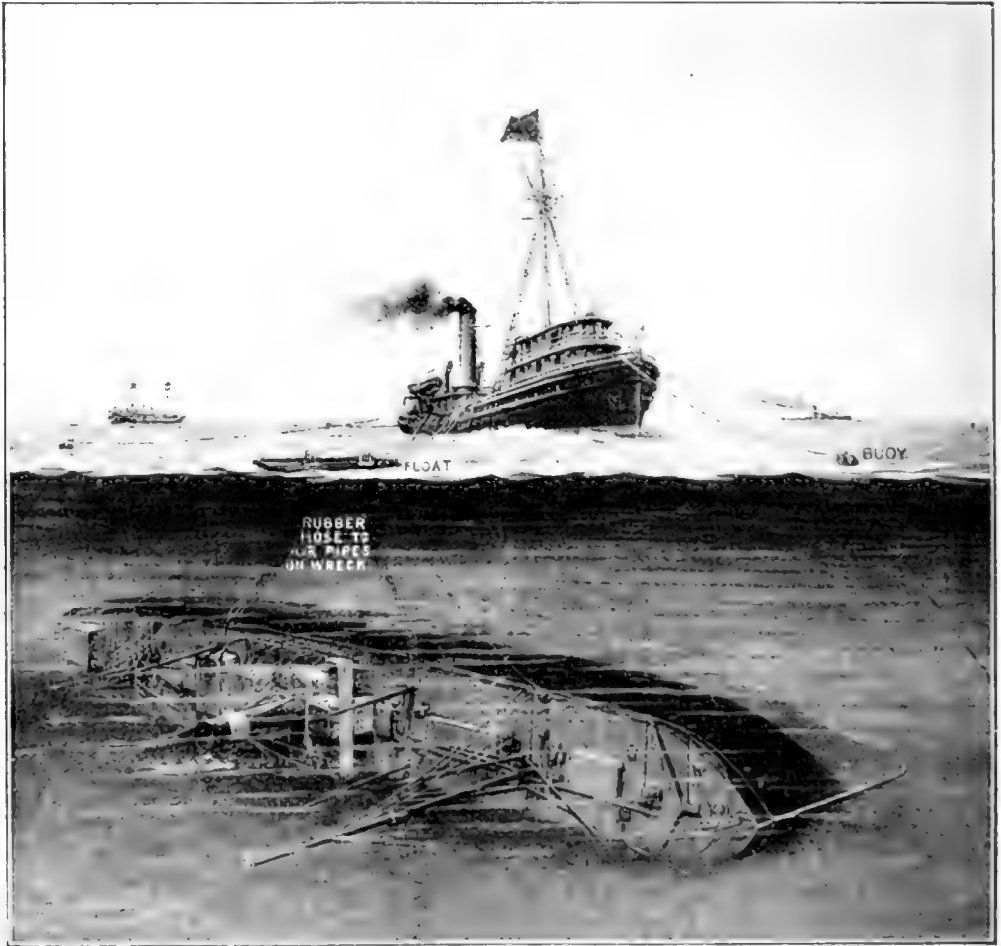

Lying fifteen miles out at sea under ninety feet of water the "Washingtonian" is being salvaged by compressed air. It is the most ambitious undertaking of the kind ever attempted

American-Hawaiian freight steamship *Washingtonian* to the surface. The salvaging of the ship represents a new chapter in salvage history.

After a collision with the American five-masted schooner *Elizabeth* in a heavy fog off the Delaware Coast on January

soaked the intruding waters and made the vessel so top-heavy that she turned end and went down on her side. Before she could be located, the water dissolved much of the sugar, thus saving the salvors the trouble of unloading her.

From the day that the vessel sank



Captain Lester A. Blake did not lose hope of her recovery, notwithstanding the fact that no vessel had ever before been salvaged while lying under ninety feet of water fifteen miles out at sea. Associated with Captain Blake in the venture are Theodore Wells, a naval architect, and William Wallace Wotherspoon, who introduced the compressed air method of floating sunken ships.

The *Washingtonian* is a steel ship approximately four hundred and twenty-eight feet long, with a fifty-foot beam. She is divided into eight watertight compartments between decks and has a watertight double bottom, extending practically the whole length of the ship. That portion of the hull which lies above the side of the hatch-openings nearest the surface formed a pocket into which compressed air was pumped. The double bottom proved to be an independent source of buoyancy.

Fortunately, the *Washingtonian* has vents extending to her upper or shelter deck. These vents lead to the several

outlets already established on the floats, and thence to the various parts of the sunken ship. The wrecking tug could thus leave the scene of the wreck when weather conditions prohibited working, simply by detaching the hose connections.

The accompanying illustrations show the way in which the vessel is to be raised. Air will first be blown into the double bottom, giving sufficient buoyancy to lift the ship off the seabed. To prevent her from turning bottomside-up a control tank with a lifting capacity of many tons will be attached by an adjustable purchase to the foremast. This will act as a lever to prevent the ship from upsetting. Finally, air is forced into the space between the decks and the upturned side, to bring the port side of the ship just level with the surface.

As soon as the *Washingtonian* is brought to the surface she will be towed inside the Delaware Capes where she will be grounded. It will then be a comparatively easy matter to right her.

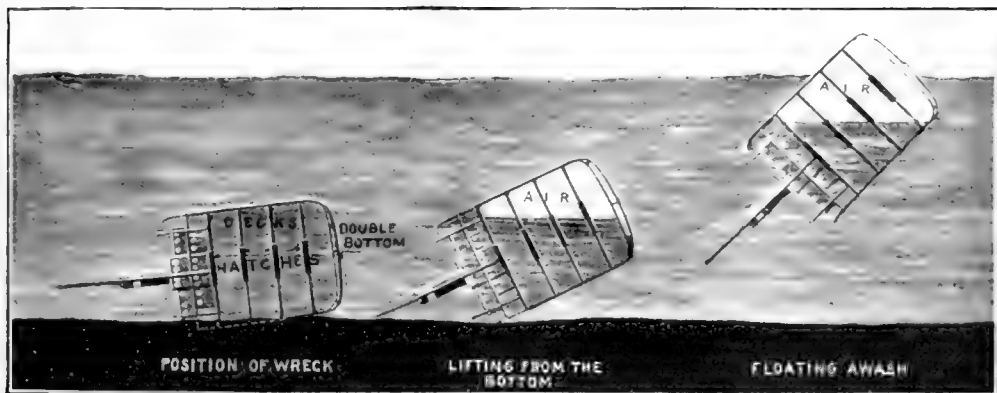

The salvors predicted that the ship would occupy three different positions as she rose to the surface. A control tank attached to the foremast prevents her from turning bottomside-up

compartments, interdeck spaces, and the various tanks. The first step in salvaging the craft is the locating of the two distributing bases, one forward and one aft. To these bases flexible rubber hose, strongly protected by wire netting, was led to a surface float upon which individual connections were placed. The float was permanently anchored over the wreck. The compressed air from the pumps on the wrecking boat was sent through flexible hose connected with the

The water will be pumped out, her wound repaired and she will be re-floated.

The scarcity of ships and the high freight rates have been two factors inspiring the saving of the ship. At the time the vessel was sunk she was valued, outside of her cargo, at a rough half million dollars. Today, if she were re-floated and able to carry large cargoes of munitions, she could bring a price as high as two million dollars.

# Plowing Snow with Your Automobile

Front and rear plows on casters which can be adjusted to any motor-vehicle chassis



The front plow automatically turns and responds to the movements of the automobile

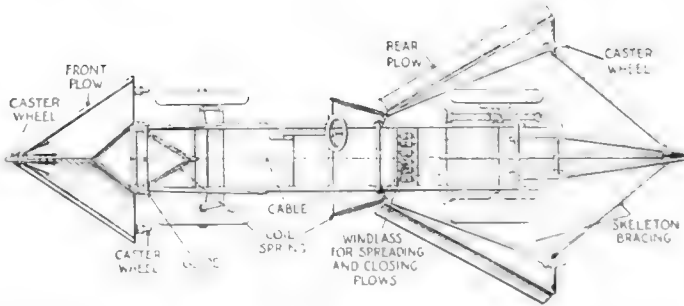

The rear plow can be contracted or expanded in order to make a narrower or a wider swath as desired

**M**OTOR-DRIVEN snow-plows have become a familiar sight in our large cities during severe snowstorms. They can scoop up more snow than a whole army of horse-drawn vehicles, and in some cities, notably New York, they have revolutionized the problem of snow removal. For the most part these plows have been attached to giant motor-trucks. Now it is possible for any motor car, from the smallest to the largest, to be equipped with a plowing attachment devised by John A. Keeler, of New Paltz, New York.

His invention embodies front and rear plows connected with the automobile in such a way that they can be adjusted up and down, laterally, and in a tilting position, and the rear plow contracted or expanded to make a wider or a narrower swath. Both plows are provided with caster-wheels, so

that they will turn to the right or left as the automobile is turned. To hold the front plow directly ahead, coil springs are used. The springs are so arranged and are of such strength that the plow will be drawn up or down according to the elevation of the road.

To raise and lower the rear plow and to spread and close it, a windlass is provided. The rear plow is attached to the automobile frame, as is the front plow; but it has the additional support of a skeleton bracing. This plow runs on three caster-wheels. Cables attached to it wind around the windlass. When the windlass is operated in one direction, the plows are spread, and when operated in the opposite direction, they are drawn toward each other. For the purpose of raising and lowering the plow independent cables are used.

**Stirrup-Stoves Afford Comfort for Cold Horseback Riders**

**U**NDoubtedly the traffic squad of the police can testify to the fact that all is not gold that glitters and that all is not comfort and pleasure that seems so. Especially is this true in very cold weather, when the gallant blue-coat seated on his beautiful charger is a worthy subject for the camera-fiend, even though his blood may be congealing in his veins and his feet rapidly becoming like blocks of ice.

The general belief is that the easiest way to keep the entire body comfortable during the cold weather is to apply heat to the feet. Acting on this idea, William French, Clintwood, Va., has invented a heater to be attached to the riding stirrups, so that policemen or other equestrians may be kept warm, however low the mercury in the thermometer may drop. The heater comprises an outer shell of metal, covered with leather so that it is inconspicuous, and lined inside with asbestos, so as to eliminate danger and conserve all the heat. In this casing a drawer is arranged to slide in and out easily. In this drawer the fuel is placed. This may be a large lump of charcoal or coke. Ventilation holes are provided through which the heat may be regulated at the

pleasure of the rider. These holes are so arranged as to provide for a circulation of the heated air and the gases around the foot of the rider.

An ash-pan is also provided, which may be made to answer the additional purpose of a storage place for unused fuel so that the fire may be replenished at intervals.

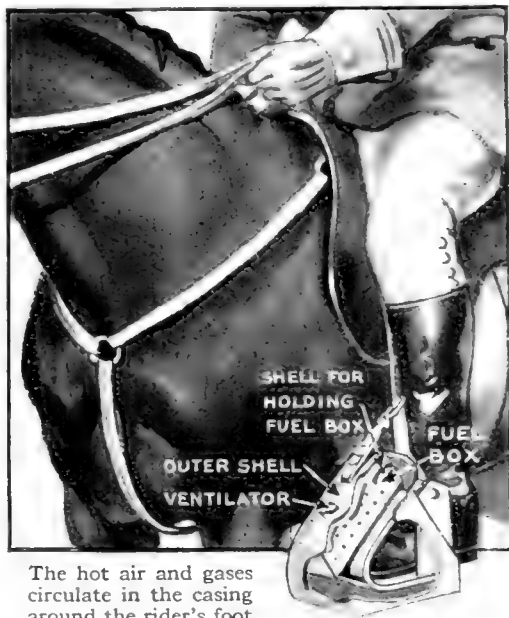

The hot air and gases circulate in the casing around the rider's foot

**An Electrically Heated Foot-Board for the Policeman**

**I**N Pittsburgh, Pa., the humane city officials have adopted a plan for providing for the comfort of the policemen while on duty. The post where the policeman is supposed to spend most of his time is provided with a small board or planking which is connected by wires with an ordinary electric battery in the call box on the corner or in any other available place. The current is regulated so that the heat generated will not exceed a comfortable degree.

By this arrangement the feet are kept off the cold streets during the very severe weather, and when the sidewalks are dry a certain amount of solid comfort is available even for the policeman.

When he leaves his post he pushes a button and turns off the current

When he returns to his post it requires only a few minutes to make the board just as comfortable as it was before the heat was temporarily turned off.



The plank is connected with the battery in the call box

# Asphyxiating a Fire with Sulphur

An apparatus which protects a ship against flames and assures it a clean bill of health

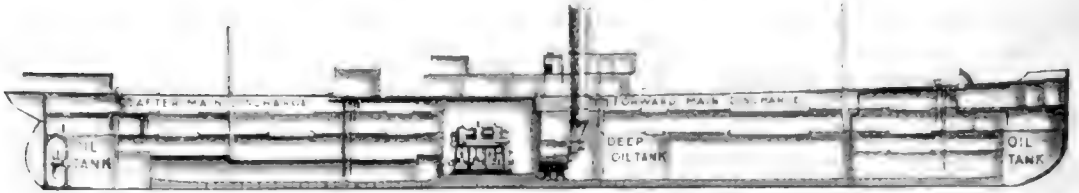

The fire-extinguishing and fumigating apparatus installed in the *Minnesotan*. After and forward main discharge-pipes connect with branch pipes which lead to each compartment of the vessel

ONE of the lessons learned in fighting ship fires is that the ideal form of extinguisher in an enclosed space like the hold of a ship is a gas which displaces the air by its own specific gravity, and is itself a non-supporter of combustion. This gas is found in sulphur dioxide, made when needed from ordinary commercial sulphur. Engineers and scientists have recognized it for many years as a fire-extinguisher. On the other hand, as an efficient gas for fumigating purposes, its value has been admitted for some two thousand years. It would seem, therefore, that an apparatus devised to utilize the gas as both a fire-extinguisher and fumigator aboard ships would meet with great success.

Such an apparatus has been installed on the American-Hawaiian steamship *Minnesotan*. It consists essentially of a furnace, a blower and an engine. The furnace is built on the principle of a marine boiler. Sulphur is admitted into the melting pot through the top, and compressed air is pumped directly into the furnace. The gas formed from the air and sulphur is conveyed from the top of the furnace back and forth through tubes surrounded by circulating water. This cools the gas, after which it is discharged through a pipe, and carried to its destination under pressure. Furthermore, the gas can be made of a quality or

density to suit a fire-extinguishing or a fumigating case.

The gas machine is placed in a steel deckhouse on the upper deck just abaft the smokestack. From this point after and forward main discharge-pipes connect with branch pipes which, in turn, extend to within two feet of the floor of each hold in the vessel. All the branch lines are controlled by manifold valves, so that the gas may be forced into any one of the several compartments.

All of the piping is of galvanized iron. Fittings are avoided wherever possible, bends being substituted. While a separate pipe line for the gas is usually provided, a combined gas and steam installation has been worked out on the *Minnesotan*. However, all pockets where condensed steam could collect have been eliminated, and there is always a

free flow of water to the drains provided, so as to keep the pipes as dry as possible for the gas.

One very important feature of the apparatus is a provision which keeps the gas from being drawn from the machine through the pumping apparatus. Only air is pumped, and that into the furnace where the gas is generated. The gas does not come into contact with the blower outfit at any time during the operation of the apparatus, either in fire-fighting or fumigating.

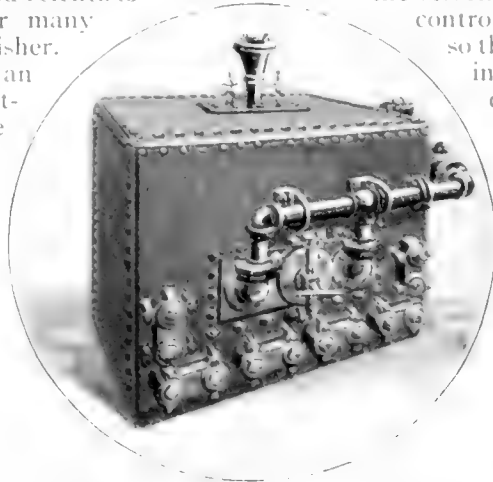

The furnace is built on the principle of a marine boiler. Sulphur is admitted through the top, and the gas is conveyed through tubes

**A Platform on Wheels for the Lamp Repairer**

THE work of keeping the electric lamps along Michigan Avenue, Chicago, in shape has been greatly facilitated by the use of a frame platform on wheels for the convenience and safety of the repairman. It consists of a frame-work of steel tubing built on a three-wheel base and supporting a small platform at proper height for a man upon it to reach the lights. There is a rail for the protection of the operator.

The platform gives the man plenty of room in which to work and has its advantages over a ladder, in giving a space for placing globes and other parts within easy reach. The apparatus can also be used for painting the posts.

When the work on any one post is done, the entire apparatus, which is on rubber-tired wheels, is pulled away to the next one. The platform can be placed close against the post, as there is a groove on the top to fit the center into the middle. Underneath it is firmly attached to the post by means of bolts. This serves to give stability to the platform as well as to bring the workman close up to the lamps. The lamp-post braces the floor, just as the three steel tubes of the frame-work brace the rim and sides. The complete structure is strong enough to instill confidence into the worker and he is able to do his repairing and cleaning without inconvenience or danger. This apparatus is said to be more convenient for the workers than raised platforms on motor-trucks. The fact that the grooved platform enables the men to work close up to the lamps instead of reaching for them is its chief advantage.

**Have You Ever Seen a Horse Wearing Trousers?**

SOMEHOW the horse in the picture below looks ashamed. Perhaps he feels conscious of the bagging of his trousers. Evidently they are not a perfect fit. Or perhaps he has never worn them before and he is simply trying to get a good look at them. For all the work-horses in Nice, France, where the photograph was taken, do not go trousered. It is only when they are called upon to do special work that they don the pantaloons.

Trousers serve to protect the animal's hide when the wagon behind him is spreading tar over the streets. A curtain

is suspended between the cart and the horse, but the trousers afford evidence of the extra care that is taken to prevent the discomfort and disfigurement which the hot tar might cause to the animal. However, France is not the only country that can boast of trousered horses. In South America a carnival is never complete without its trousered horses and sheep. Not only are they trousered but they are fully dressed.



A groove is provided in the center of the platform into which the lamp-post fits closely

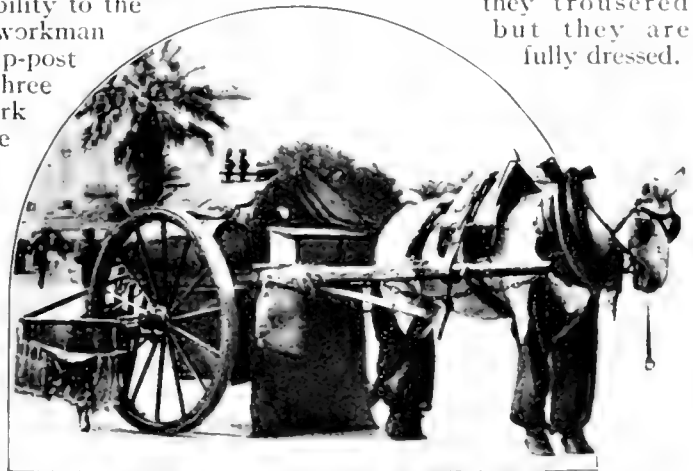

The trousers protect the animal's hide from the hot tar which is being spread on the streets from the cart behind

### Why Does Sap Rise in a Tree Against the Pull of Gravity?

NOT everybody knows that solutions of two different substances placed on opposite sides of a membrane or a pulp make diligent efforts to equalize their density.

For example, take a glass tube, cut off the lower end of a potato, and peel the remainder for about one-third of its length. Bore a one-inch hole through two-thirds of the potato and in the end fit a cork. Bend a glass tube into L-shape, put vaseline on the short arm and insert it in a small hole bored in the side of the potato to reach the big hole. Fill the interior of the potato with sugar colored with ink, fasten the cork and glass tubing tight. Place this apparatus in a dish of water. The water, flows through the pulp of the potato and on reaching the thin membrane separating it from the colored liquid it diffuses more quickly through the colored liquid than the latter does through it, because it is less dense than the colored liquid. This causes the water to push the denser liquid upward into the tube. This action, together with capillary attraction is what causes the sap to rise.

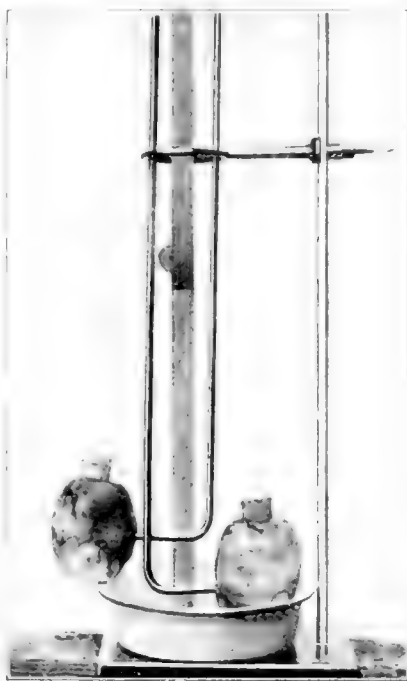

An experiment with potatoes to illustrate the principle involved in the rising of sap in a tree

### A Time-Saving "Safety-First" Tool for Dynamite Workers

MAKE - SHIFT methods of crimping dynamite caps and connecting the cap and fuse to the cartridge have led to scores of severe accidents and many fatalities in land-clearing work. A combination tool, which will cut and slit the fuse, crimp the cap on the fuse and finally punch clean-cut holes in the cartridge for the secure fastening of the cap and fuse to the cartridge has been devised by V. D. Livingston, land clearing demonstrator, Wisconsin College of Agriculture.

The arrangement for slitting the end of the fuse exposes a pocket of powder which will ignite quickly. The crimping device at the center of the tool does a neat job and a strong one. When properly used to crimp a cap to the fuse, it requires a twenty-five pound pull to remove it. One of the handles has a pointed end, designed for punching the holes in the dynamite cartridge. The apparatus is intended to save time as well as to insure the safety of the workers.

A combination tool which will cut and slit the fuse, crimp the cap and punch clean holes in the cartridge

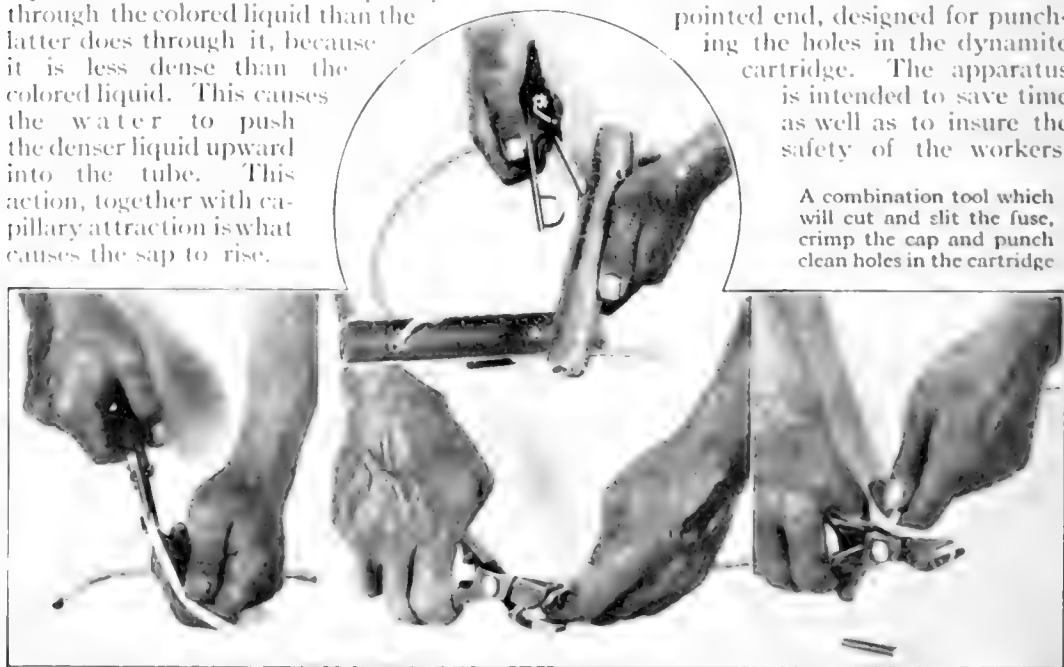

If Robinson Crusoe Had Only Thought of This

THE average man has enough ingenuity to build a shelter for himself anywhere. If ordinary materials are not at hand he immediately proceeds to find something that can be made to answer the purpose, whatever may have been the use for which it was originally intended. The man in the photograph

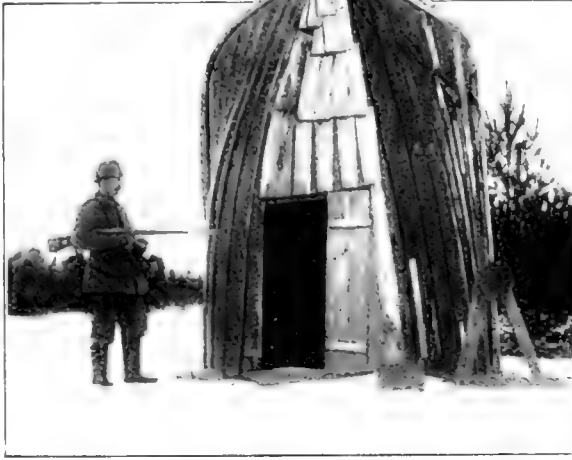

The sentinel's hut made out of the keel of a discarded boat. When made watertight by patching and filling the gaps it made a comfortable enough shelter

was doing sentry duty "somewhere" in the war zone, and the only material he could find that was at all available for shelter was the keel of an old boat that had been beached and discarded by its owners. This he cut in half and erected as shown, using the short lengths and waste pieces of board for a door and to fill in the gaps. In this he was protected from every kind of weather.

At right: Valentine Reineger with his ornate blown-glass pipe which holds almost a pound of tobacco

Below: The cannon, which is made of blue and flint glass finely balanced



Curios Made by Glass-Blowers in Their Spare Moments

THE automatic glass-blowing machine has not only supplanted the man who formerly did the work by hand but has deprived the glass-blower's friends and relatives of the many curious and interesting things which it was his custom to make during his spare time for his own amusement or profit.

Valentine Reineger of Alton, Ill., 65 years old and a retired glass-blower, had the distinction

of being one of the most expert in the country at making odd pieces. His productions ranged from articles in common use to those of warfare, and he frequently blew images of animals.

The glass pipe shown in the illustration was his most difficult piece. It is five feet high. The bowl is three inches in diameter and six inches deep. It would hold nearly a pound of tobacco. The pipe is decorated and weighs nearly ten pounds.

Of course the pipe is intended only for ornamental purposes. It would be hard to conceive of the most inveterate smoker indulging in a full-pound smoke, unless he happened to be sitting at an Indian peace conference.

The cannon at the left is of blue and flint glass. The greatest difficulty encountered in making it was in securing a balance. A sword and sheath of flint glass and of natural size is another implement of war made by Mr. Reineger.

His blown-glass animals include horses, cows, reindeer and alligators which are true to life in almost every detail of general appearance.



# The Time, Labor, and Money-Savers Among

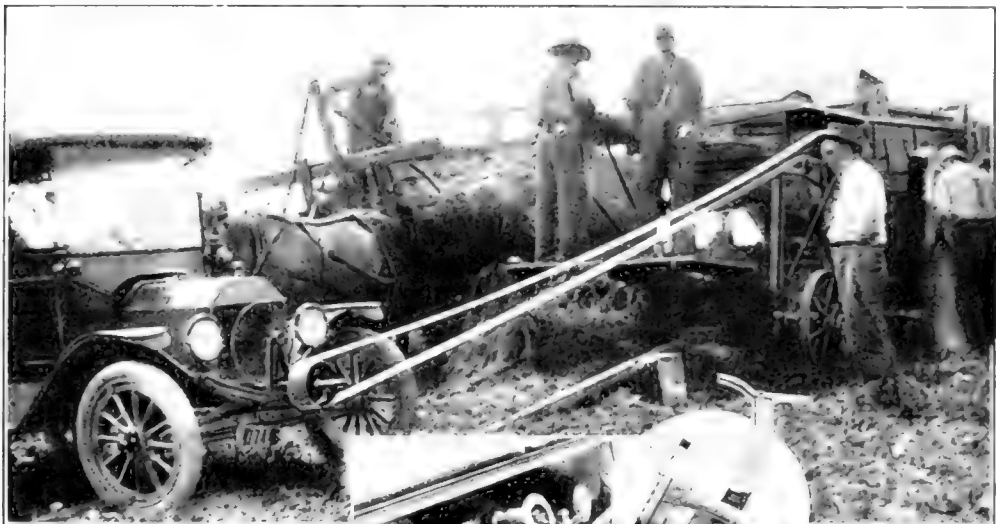

Above: Threshing with a Ford. The power is taken directly off the crankshaft by means of a novel device  
Below: A lamp socket warmer for engine and radiator during the winter



At left: A brake-pedal lock to prevent theft. The lock is a wedge bolt inserted between levers

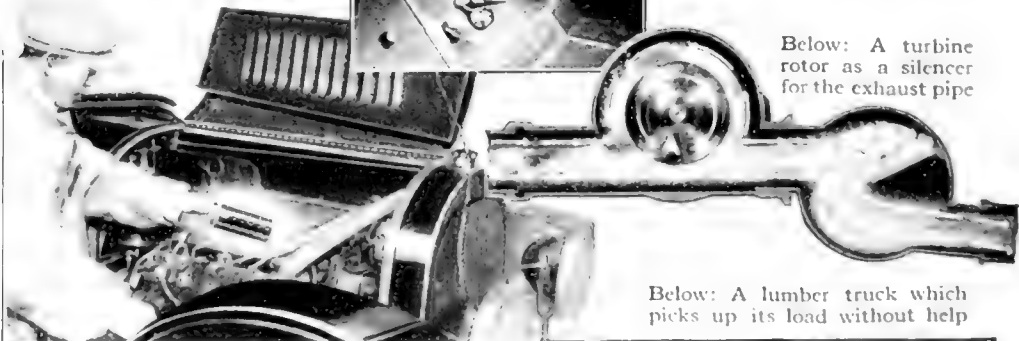

Below: A turbine rotor as a silencer for the exhaust pipe

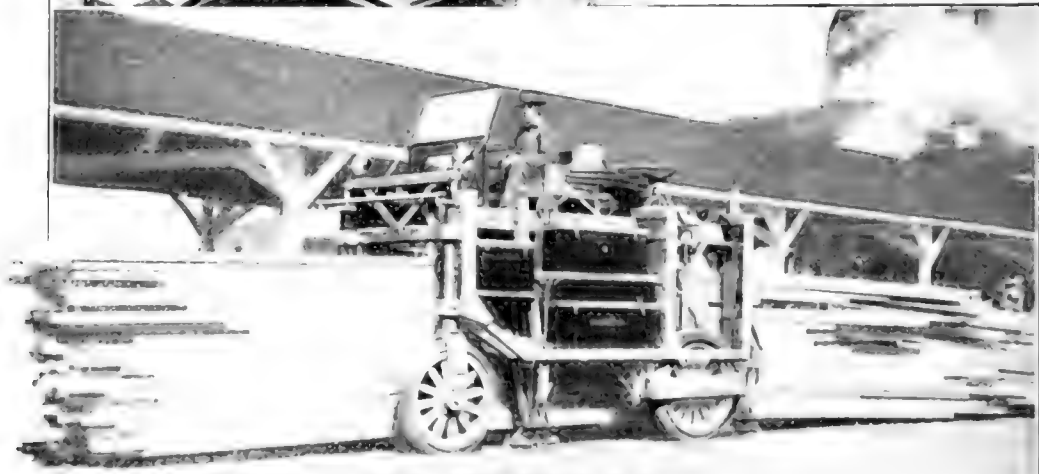

Below: A lumber truck which picks up its load without help

# Recent Improvements in Motor-Driven Vehicles

At right: A leather spring-cover with a felt lining saturated with oil lubricates the springs

A motorcycle limousine with its owner at the door. Why not construct taxicabs like this?

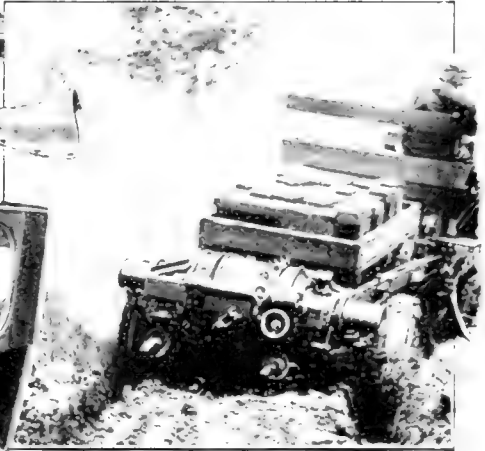
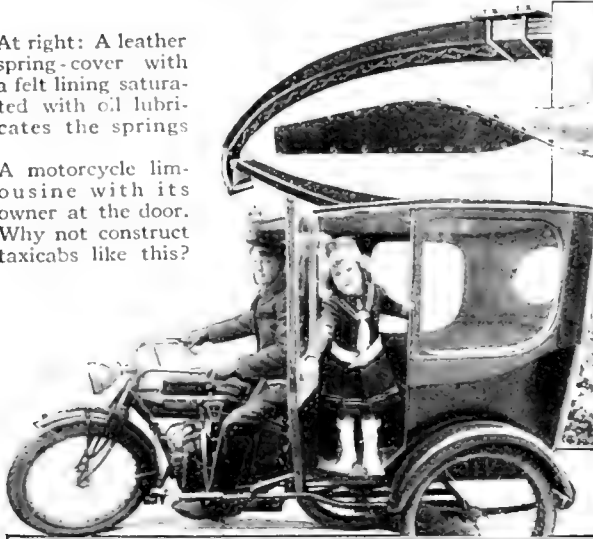

Above: A wrecking truck with a power winch and lengthy steel cable



At left: An adjustable accelerator heel-rest is one of the newer refinements introduced by an inventor



Above: Storage-battery tractor drawing trailer-trucks in a freight-transfer station. Each tractor can handle at least 180 tons of material each working day

At right: A four-wheel drive automobile comes to the rescue of a marooned truck in Mexico. It pulled its load through fifteen miles of adobe mud without trouble

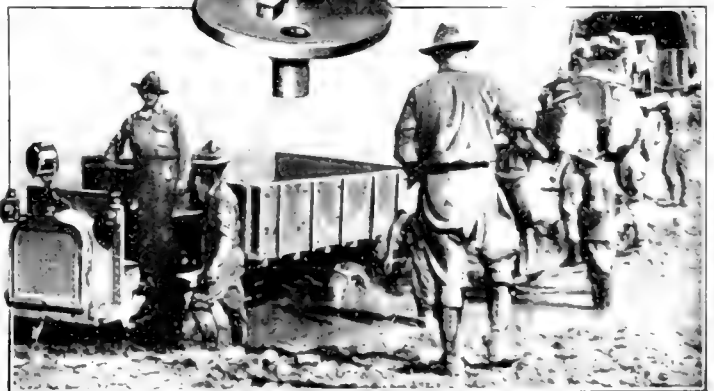

# Here Are Some More Practical Ideas Designed to

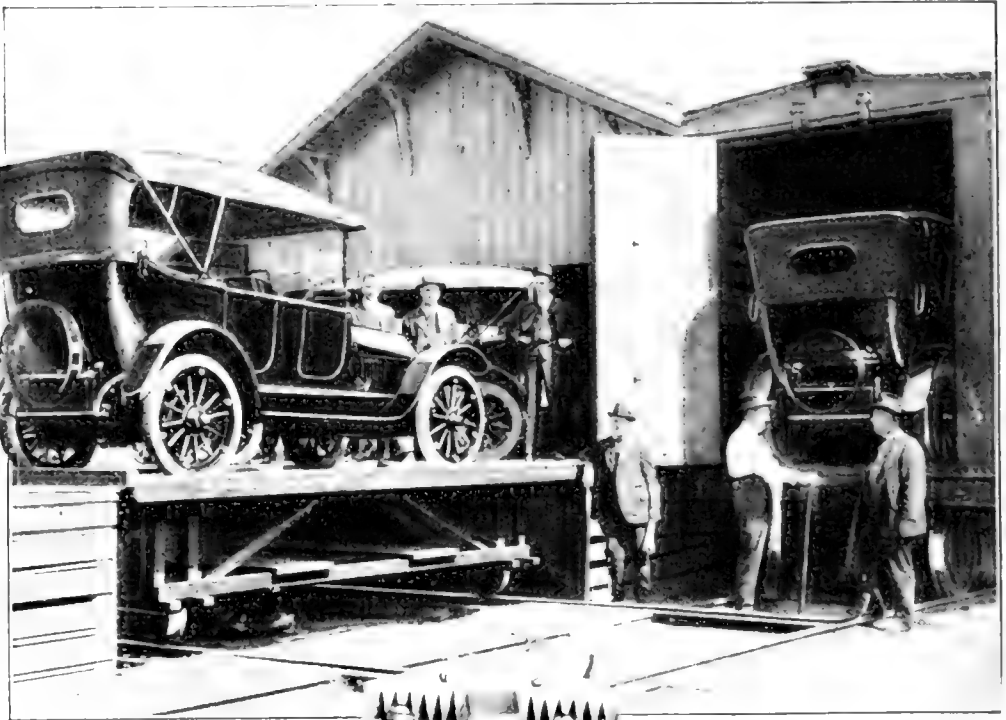

Above: Removing automobiles from box-cars with a movable platform which ordinarily remains a part of the warehouse

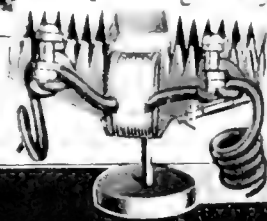

At left: Controlling Ford lights by a reactance-coil with a variable gap in its magnetic circuit to regulate the current



Above: A two light bulb case in a steel cylindrical tube is handy when locating trouble

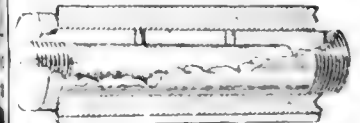

Above: A lubricating-bolt with an oil-soaked wick automatically lubricates parts which slide over each other

At left: The speedy sidecar motorcycle fire apparatus, equipped with chemical extinguishers, lanterns, axes and other emergency tools is appearing in our more progressive rural communities

# Increase the Usefulness of the Motor Vehicle



The buggy carries not a tail-light but a reflecting prism, which sends back the light from the lamps of vehicles behind it

Below: Not a dimmer but an intensifier of the light on a road



Rel Disk

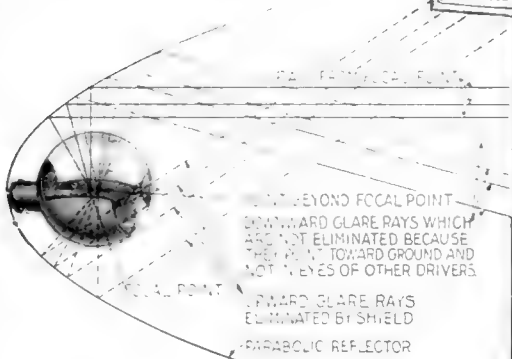

BEYOND FOCAL POINT —  
DOWNWARD GLARE RAYS WHICH  
ARE NOT ELIMINATED BECAUSE  
THEY POINT TOWARD GROUND AND  
NOT IN EYES OF OTHER DRIVERS.

UPWARD GLARE RAYS  
ELIMINATED BY SHIELD

PARABOLIC REFLECTOR



At right: A three-section garage door which slides around a corner on a track  
Below: Portable loaders mounted on wheeled frameworks for unloading freight

Below: A grease and oil gun that requires no screwing, air pockets or paddles. The gun is loaded by removing the lower cap and filling it

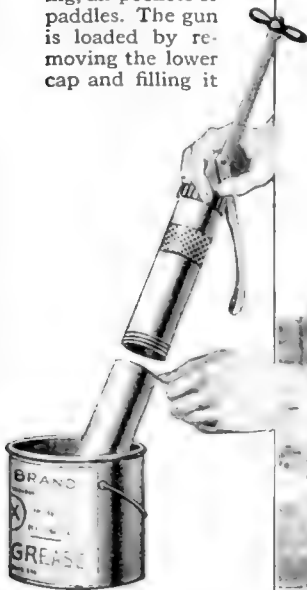

# Painting Wild Animals' Eyes

It is the natural expression, not the hypnotic stare that is sought

By A. H. Ewing

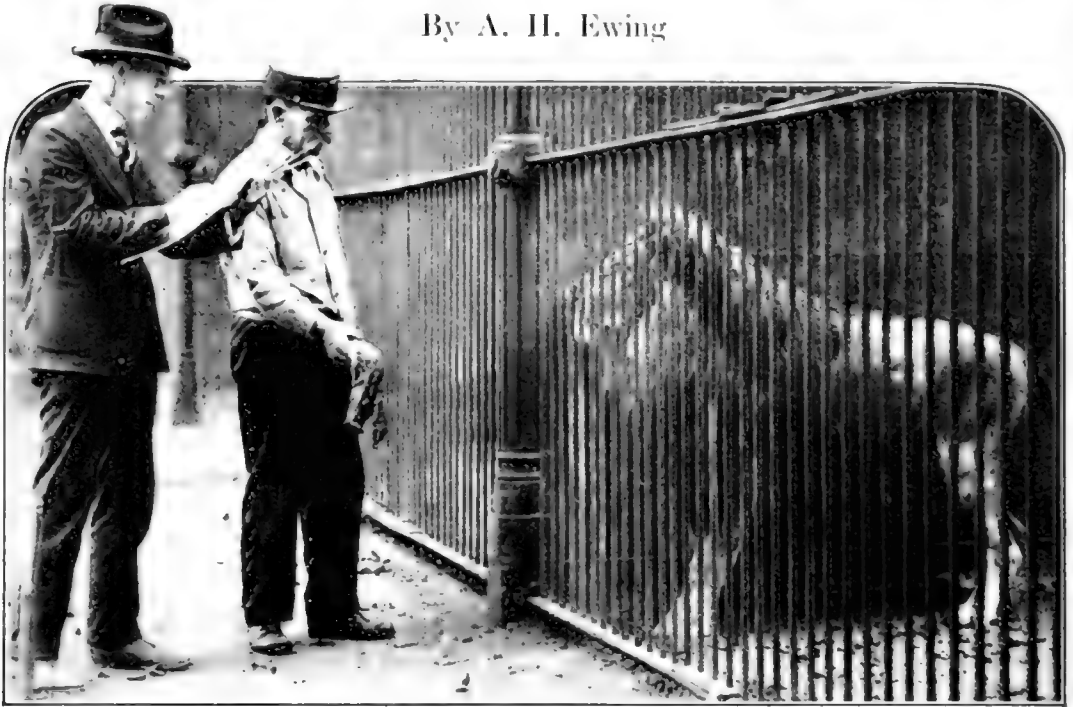

The process of painting from life the eyes of the animals involves many hours of patient waiting in the effort to catch and hold the gaze of the restless, indifferent or resentful imprisoned beasts

**N**OW that taxidermy has become an elaborate art, the sportsman and the museums alike demand an absolutely life-like aspect in a "mounted" specimen. Mr. Wilson Potter of Philadelphia, hunter of big game and taxidermist, has an entire building in the city fitted up with every appliance for perfecting the art of modelling and mounting his trophies of the hunt. An expert sculptor and an equally expert taxidermist are at work in the shops, and the truly marvelous result of their work is shown in the museum, at the Broad Street front of the building. Despite the high grade of the work, however, Mr. Potter decided, a few seasons ago, that even the best workmanship left much to be desired in the finished effect, so long as the eyes supplied by manufacturers were used. The camera did not aid him, and so Mr. Potter looked about for an artist who could reproduce the vast differences in the eyes of the various species of animals, and the shape, color, size and expression of each, as well as catch an expression to suit any pose which might be chosen for a "mounting."

David Finkelgreen, a Philadelphia artist, undertook to give Mr. Potter exactly what he wanted. When not engaged in his winter presidency and directorship of the Graphic Art Club, Mr. Finkelgreen went far to make a careful study of wild animals' eyes, often under difficult and dangerous circumstances; he also dissected eyes of animals which had been shot in the chase. His work in the Zoological Gardens, painting eyes of the animals in cages, aided him much in perfecting the art of reproducing the eye with his brush. The process called for many hours of patient waiting and effort to catch and hold the gaze of a restless, indifferent, or resentful beast long enough to bring it to the hypnotic stage when the painting could be done. Holding a box of paints in his left hand, the artist paints in the cup-like inside of a crystal mold, always allowing for the difference in effect made later by the upper covering of crystal when the eye reaches completion.

The artist continued his efforts until he became the foremost painter of animals' eyes in the world. It is easy to realize this

when one turns, with relief and pleasure, from the case of manufactured eyes, shown in the showroom of Mr. Potter's building, to the case of glowing, liquid, or gem-like hand-painted representations. The experience does not only enlighten one as to the wide range of differences in the eyes of various kinds of beasts, in the marking, rim, shape, size, coloring and expression, and particularly in the colors of the pupils and their curve-like, slit-like or round shapes; it also shows what remarkable results can be obtained in this unique phase of fine art.

And the perfecting of this phase of art was made possible by a determination on the part of Mr. Potter, which stopped at no expense, from several dollars apiece for the imported crystal molds from England, to financing long trips, and engaging the best artist obtainable—in this case, Mr. Finkelgreen.

#### Warning Herdsmen of the Approach of "Untempered" Storms

**T**HROUGHOUT the Northwest, where sheep-raising is one of the principal industries and where the weather is not always tempered to the shorn lamb, for the simple reason that shearing and lambing are scheduled for the very early spring, the loss to the herders from deaths, due to exposure in sudden storms, sometimes totals fifty per cent of the flocks.

For this reason, during the Spring of 1916 the Weather Bureau installed a special storm-warning service for Oregon, Washington and Idaho sheep ranges. The service was operated through twenty-five distributing centers. Special reports and warnings were sent out, covering temperature, rain, snow, winds, clouds and a clear sky. The messages were passed along by telephone and reached stockmen by noon or earlier of the date of issue.

#### Are You Paying for Your Farm or Is It Paying for Itself?

**T**HE progressive farmer does not measure his business by the number of acres which his property embraces; for in many instances it is the man who does an intensive business on a comparatively small acreage who makes the most money out of farming. Usually the farmer has altogether too much money tied up in unproductive, or loafer, land.

On every farm, of course, there are certain areas necessarily devoted to nonproductive purposes, such as fence lines, ditches, lanes and building lots. The problem is to decide just how great a percentage of the aggregate land may be devoted to such uses profitably, or at least

without detracting from the yielding capacity of the farm. For instance, untrimmed hedges, fences, or zigzag rail or worm fences require more than twice as much land as woven wire or barbed wire fences.

Similarly, a little planning may result in the elimination of farm lanes by a simple arrangement of fields; and a compact grouping of the farm buildings, with due regard for hygiene and attractiveness, may restore a considerable portion of the nonproductive acreage to the profitable class.

Some areas are hopeless, but before being pronounced entirely unreclaimable their possibilities should be considered from every angle. Many untillable fields make productive pasture lands, or they can be used for the production of timber. On the other hand it may be an advantage to clear and till wooded acreage, first counting the cost of the work and balancing it against the sale price of the timber products, the increased value of the land and the added expense of firewood after the timber has been disposed of.

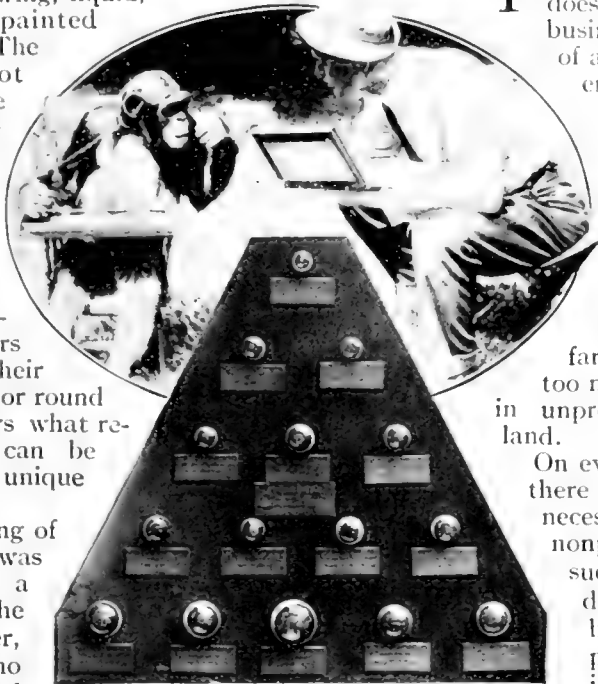

The artist paints on the crystal molds the exact coloring, shape, size and expression of the eyes of the different animals. A crystal covering completes the eyes which are then labeled and filed in cases



# Renovating the Old Golf Ball

Perhaps this is the great bonanza of which the caddies are dreaming

The ball is forced between the two spring-holders on the cover of one of the paint pots and is lightly impaled on the center pin

The cover of the can becomes the holder for dipping the ball into the enamel, after which it is screwed back into position



**W**HEN the golf ball loses its original good looks and the paint begins to chip off and crack, it is thenceforth regarded as practically worthless for a good game. But a ball which has been coated with enamel paint may be cleaned and painted again, making it as good as new.

A kit for cleaning and painting the balls consists of two cans, one No. 2, for holding sufficient enamel paint to cover fifty balls, and one No. 1, for a supply of paint remover, of which three bottles will be required. One bottle of enamel should also be included in the equipment. A device for holding the balls during the dipping and drying process has been invented by G. H. Lambert, of Asheville, N. C. It consists of two spring-holders and a central pin which fastens to the top of the can.

The ball to be renovated is first washed and dried and the old paint thoroughly removed. Then it is forced between the two spring-holders on the cover so that it is lightly impaled on the center pin. It is then dipped into the enamel, withdrawn and the cover reversed and screwed on the can, leaving the ball in its position on the center pin until it is perfectly dry.

In about two hours it will be dry enough to handle and in about six or eight hours it may be used again in the game.

Care should be taken that the ball is entirely covered when it is dipped in the enamel. When it is withdrawn from the enamel-bath it should be held over the can containing the enamel until the surplus

paint has drained off. This is a matter of economy as well as cleanliness. The cover should be replaced quickly over the enamel-can to keep the air from the contents.

As the enamel becomes used up, the ball may not be entirely coated by just dipping it into the can, but if the cover is held securely in place by the thumb of one or both hands, the can may be tilted and the enamel splashed over the ball by shaking the can from side to side. If the enamel becomes too thick the enamel-thinner may be added. This should be stirred in thoroughly, good judgment being used to get just the right consistency. If too much of the thinner should be used and one coating of enamel should not give satisfactory results the ball should be redipped, but it should first be reversed to insure an even coating.



The cigar-shaped bubble-blower is filled like a fountain pen, and it will blow innumerable bubbles

Johnny Blows Bubbles from His Toy Cigar

**A** BUBBLE-BLOWER that is shaped like a cigar and that fills like a fountain pen eliminates the muss and trouble encountered with the common blower. After the little vial shown in the illustration is partly filled, hundreds of bubbles may be blown without further trouble. The blower is a source of great amusement to children, and mothers like it because it does not drip the suds. The youngsters will doubtless regard it as being as superior to the ordinary bubble-blower as a Perfecto is to a pipe.



**Indoor Tomato Plants Fifteen Feet High**

**T**OMATO vines thirteen feet tall may sometimes be grown in a garden, but as far as investigations have shown that is the limit. A few years ago a large field of tomato plants of that height was grown in Charleston, West Virginia, but two workmen in a factory in Glenbrook, Connecticut, have recently excelled this. They have grown one plant on a trellis, from which the tomatoes could be picked at a height considerably above one's head, and the actual length of the vine reached fifteen feet.

Tomatoes occasionally emphasize their vine-like characteristics, probably more frequently within doors than out of doors.

To produce tall tomato plants in any place, pinch off or cut off the seed pods. All the energy of the tomato is then transferred into the terminal. The same principle may be applied to any tree. Small trees, such as willows and maples, if trimmed too much on the side will soar so high and become so slender that they will go over to the ground—top-heavy, as the forester would call it.

The species of tomato which usually grow to great height are the small kinds. The fruit grows in great profusion, and is so attractive in appearance that in many localities the vines are grown for decorative purposes. It was the small red variety which was formerly called the "love-apple" and was cultivated for its beauty long before it was known as an edible fruit.

These plants with their profusion of dark foliage, if trained over wire netting, make good garden fences where space is valuable.



A tomato plant grown in a window-box. The plant attained a height of fifteen feet and bore abundant fruit

**Valuable Products May Be Obtained from Cherry Pits**

**S**IXTEEN hundred tons of cherry pits, now a source of annoyance and expense to canneries, can be made to yield two valuable oils and also a meal for feeding cattle, according to specialists of the U. S. Department of Agriculture. In addition the 105,000 gallons of cherry juice now wasted in seeding cherries can be turned into desirable jelly and syrup, or even into alcohol. A saving of these valuable by-products from cherry canning may make possible the domestic manufacture of substitutes for almond oil and bitter almond oil, now imported, and at the same time establish a new industry in the cherry packing districts of the North Atlantic, North Central, and Western States.

**An Automobile-Pump Driven from the Rear Wheel**

**F**OR pumping up automobile tires by the power of the motor, the usual practice is to mount the pump along with the motor on the front of the car; but this has the drawback that the pump can never be removed to be used on another car. A new idea which is shown in operation in the illustration below employs a separate pump and has fittings for placing it on the side of the car. The piston of the pump is driven by a rod from the rear wheel of the car by the use of a special piece which is readily clamped on the wheel. By this arrangement a larger and more substantial air pump may be used than is usually employed where the installation is permanent. This of course means more rapid and efficient work, which implies a saving in valuable time, temper and patience for automobilists.

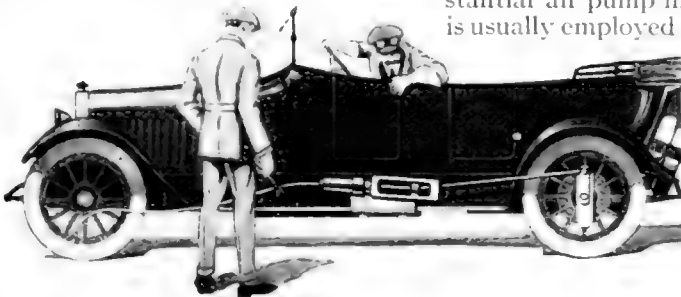

The piston of the pump is driven by a rod from the rear wheel by means of a special member clamped on the wheel

### What? Tail-Lights for Mules! Yes, Here They Are



Above: How the tail-lights assist the mule-driver behind his pack train. At right: The light attached to the tail

**T**HE mule, the most used and abused of pack animals, doesn't know much about hitching his wagon to a star, but inventive man has come along and has hitched a star to the mule's tail. All this has been done to protect the mule's life, and to prevent him from losing himself and making trouble when he is but one mule in a drove of mules.

Recently a disastrous accident occurred near Los Angeles when a woman driving an automobile along the highway ran into a drove of mules. The automobile was wrecked, the woman was injured, and two of the mules were killed. A court action was later filed against the owner of the mules, and the woman was awarded substantial damages.

It would seem at first thought that the owner of the mules rather than the automobilist was entitled to damages; but the judge must have known something about mules and understood the odds.

As a result of the accident the mule owner devised a tail-light to be worn by his animals after dark. It is a light of the simple reflectoscope type, such as is used by bicyclists. When a pack train of mules is driven along at night each mule is adorned with a light. This enables the driver, far in the rear of the lead mule, to note the position of each animal in line and the direction he is taking.



### The Tiniest Motorcycle To Be Used in the Army

**S**OME interesting experiments were made recently by Captain Frank E. Evans of the United States Marine Corps with a view toward establishing the practicability of a small motorcycle designed by Hugo C. Gibson.

A private, equipped in heavy marching order, tried out the machine. He had had no previous experience with automobiles or motorcycles. Yet his success in operating it has led to the belief that it would be a welcome addition to the fighting equipment of our soldiers.

The machine will carry as much as three hundred pounds and attain a speed of twenty-five miles an hour, although its weight is but fifty pounds. It takes hills easily. Private Davis, who tried it out, found no difficulty in ascending a fourteen-degree incline.

The machine is so small that it will turn around sharp corners without danger. It is so light that it may be lifted over any ordinary obstacle. One of the tests consisted in riding it up to a four-foot fence, stopping the engine and lifting the machine over the fence, all of which was done with very little delay. If the man who delivered the famous message to Garcia had had one of these his task would have been easier.

The dimensions of the little machine are forty-eight inches by nine inches by eighteen inches. It is almost small enough to be a plaything. Yet it will carry three hundred pounds for fifty miles at an operating expense of ten cents.



It looks tiny, but it will carry three hundred pounds at twenty-five miles an hour

# The Giant Destroyer of the Future

Can a juggernaut be built which will annihilate a whole army?

By Frank Shuman

*Illustrated by Edwin F. Bayha*



*(The author is a distinguished engineer who invented the daring sun-power plant described in the October issue of the POPULAR SCIENCE MONTHLY. His concrete piles, wired glass, wool-degreasing machines and other inventions have made him famous.—EDITOR.)*

**A** CLUB, a bow and arrow, a blunderbuss, an infantryman's rifle, a forty-two centimeter howitzer are merely instruments for delivering blows. The essential difference between the battles of prehistoric times and those of today lies in the manner of delivering blows. Smokeless powder has merely lengthened the arm of a modern fighter. He strikes and kills at a distance of miles.

For all our machine-guns, for all our terrible "artillery preparation," battles are still won by bayonets. Tactics have been somewhat modified since Napoleon's day, because of the invention of the machine-gun and the high-powered field-piece. But the individual fighter is still as important as he ever was. We speak of the German or French or Russian "war machine," when we mean a million or more individuals trained to act with a precision that roughly approximates that of a modern university football team.

## *Only the Battleship Is a Real War Machine*

Because armies are still composed essentially of many individuals, fighting ships may be more fittingly termed "war machines." A modern battleship is a real machine. The men on board are merely so many intelligences that control the steam-engines, the turrets, the great guns, the searchlights. No one ever hears now of hand to hand conflicts at sea. Ships are sunk at ranges of five and seven miles. But land warfare is still waged not by a few machines, as on the sea, but by organized millions of men.

Armies have increased in size. Fighting ships, on the other hand, have diminished in number. Contrast the numerical strength of the British Navy now with what it was in the days of Drake and Nelson. A few dozen ships, highly intricate machines, have taken the place of hundreds.

Why is there no land battleship, something comparable with our own *Penn-*

*sylvania*, something which will concentrate within one volume the striking power of an army?

### *Why Not a Battleship On Land?*

There is no good engineering reason why an enormous wheeled structure, heavily armored and capable of traveling at high speed should not wage the battles of the future. Technically, it is a far easier task to design and build a super-dreadnought than a wheeled destroyer to run on solid ground. The ocean is a vast, level expanse. There are no hills and valleys. Water is the same in density everywhere. But land varies from the hardest rock to the softest quagmire. Here we have the reason why we still oppose armies against each other instead of machines.

Undeniable as these difficulties are, it seems to me that they could be overcome by boldly designing a machine of such dimensions and of such energy that it could travel over ordinary

land much as an automobile travels over a country road. A hill fifty feet high would be to that machine what a six-inch ridge of clay would be to an automobile; a swamp would no more hinder its course than half a foot of mud would stop a touring car. Its speed would be at least one hundred miles an hour on the long, level, sandy beaches along our coasts. And even over rough inland country it would rush far more swiftly than any touring car on a poor road. Indeed, in its speed would lie its destructive possibilities. The impact of a heavy mass moving with the velocity of an express train would be irresistible. It could mow down everything before it with the relent-

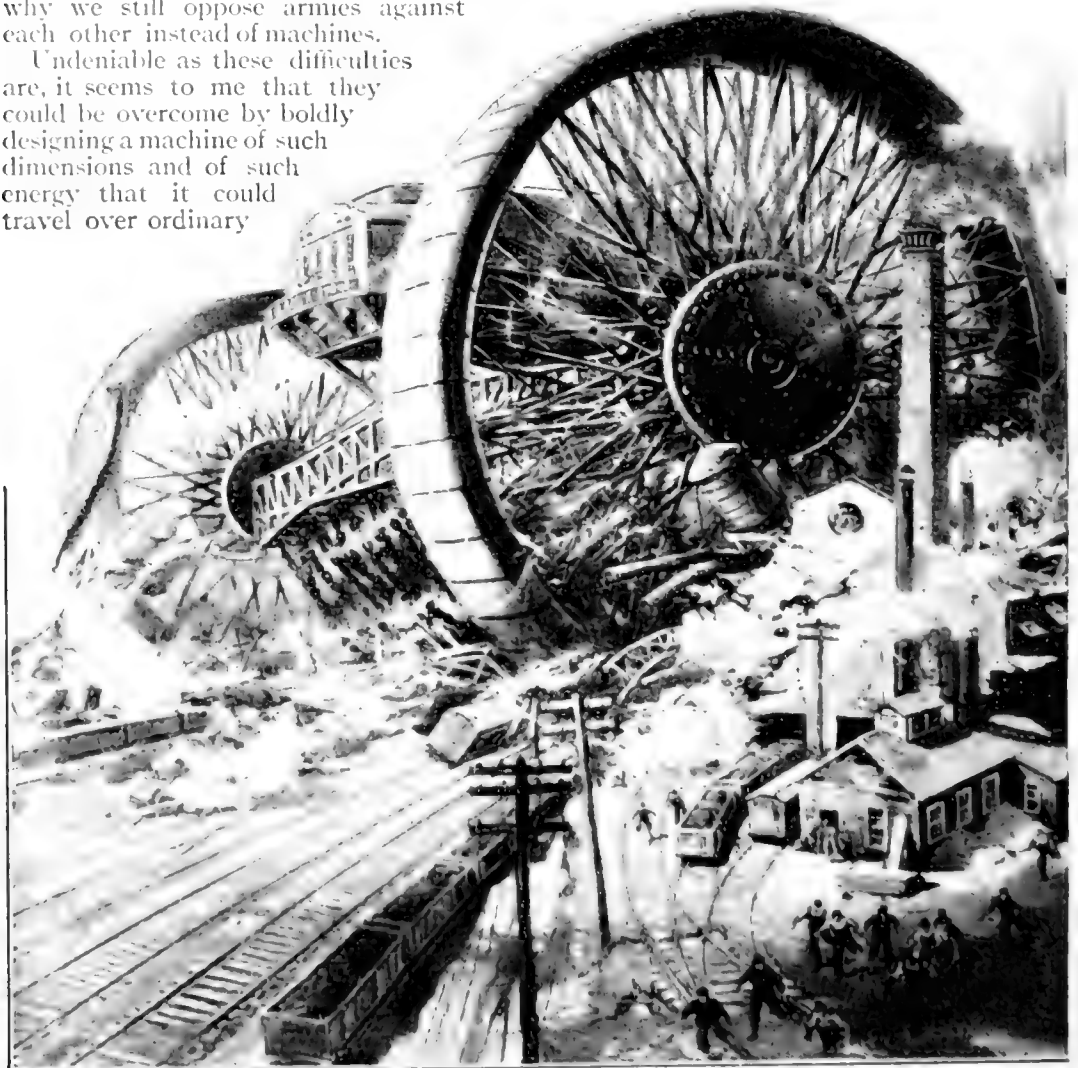

The machine proposed by Mr. Shuman would be irresistible. With its front wheels measuring 200 feet in diameter, and the weights aggregating many tons dangling down in front from chains,

lessness of a steam-roller. Guns would not be required to rout an enemy. An army would be as helpless in offering resistance as a flock of geese in the path of an automobile.

#### *A Giant Three-Wheeled Armored Car*

It is impossible within the limits of a short article to describe this machine which I have conceived in all its details. Picture to yourself, however, a self-propelled machine, comprising three wheels and a heavily armored body or car. There are two wheels, one hundred and fifty to two hundred feet in diameter in front, and a single smaller steering-wheel in the rear. The entire structure is short, so

that the turning radius will be small.

No doubt you are familiar with the military masts of our American battleships. They are latticed towers, not unlike cages. They are thus constructed so that whole sections of the lattice work may be shot away; but the remaining portions will still support the mast.

So I would build the wheels of my war machine. Why not armor them instead? They would weigh far too much—thousands of tons in fact. But the hub I would armor—and heavily. There the spokes would be concentrated so thickly that they might be shot away in great numbers. Besides, the hub and axle must be well protected. Therefore the center of each wheel would be a mass of armor as thick as that of a battle cruiser.

The two front wheels of this war machine



it would plow through a whole town, blotting it out of existence as if it were a mere ant-heap. The wheels would be latticed, so that shot might pass through without destroying them

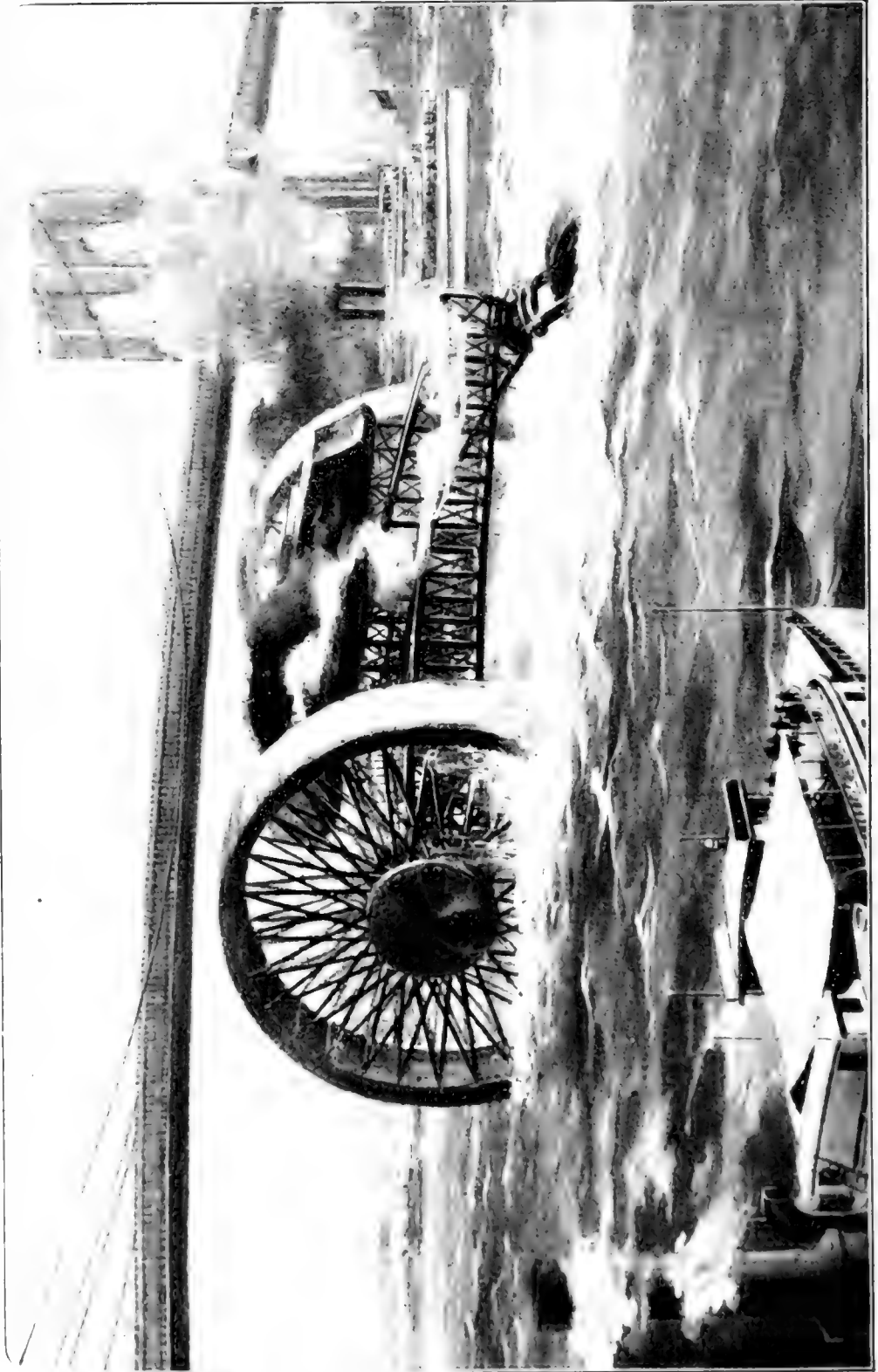

Ordinary rivers and marshes would not stop the machine. Few rivers are more than fifty feet deep. The 200-foot wheels of the machine would dash through them as easily as an automobile through a pool of mud



would have to be spaced about three hundred feet apart. They would have a tread about twenty feet wide,—in other words, about as wide as an ordinary room. I would make them of steel plates four inches thick, bolted together in sections.

Since the machine is to destroy by virtue of its inherent energy and not by means of guns, it would have a comparatively small car—a car which would not rise above the tops of the front wheels, which would be heavily armored, and which would serve primarily as a housing for the engines. The crew would be small—not more than perhaps thirty men.

I am fully aware that the problem of obtaining engines which will give this war machine a speed of one hundred miles an hour is not easily solved. But if thousands of horsepower can be developed by the engines of pitching and rolling battleships it is not unreasonable to suppose that competent engineers can be found to design and build steam engines of twenty thousand horsepower, fed by oil-fired boilers.

Once more let me state that the front wheels are one hundred and fifty to two hundred feet in diameter. Hence, they would make less than fifteen turns to the mile.

#### *How Shocks Would Be Absorbed*

That simplifies the matter of absorbing shocks. If a racing automobile on a fine track leaps into the air when it strikes even a pebble, simply because the spring suspension has not time to respond to the shock, it is obvious that the huge structure that I have in mind must be provided with inordinately strong yet sufficiently sensitive shock-absorbers. The shock that would be experienced in knocking down a small factory building, would certainly not be as great as the shock that must be absorbed as a modern fifteen-inch naval gun suddenly recoils after discharge. If cylinders filled with oil can check the terrific recoil of a big gun, they can also act as shock-absorbers on a land war machine. And so they can be imagined on the machine—huge cylinders, three feet in diameter, filled with oil which would resist the pressure of pistons on the axle.

The weight of the entire structure would be probably five thousand tons. Since the machine is to batter down everything in its path, there are to be suspended from the front of the machine a series of heavy weights, each weighing several tons. The weights may be raised or lowered. When

dropped into position their impact at high speed would level everything before them.

#### *Only Big Guns Could Stop the Machine*

Terrible as this contrivance would be, it would not be able to withstand bombardment by 16-inch Skoda or Krupp guns. It is not intended for that. Ordinary field artillery will not stop it. Its sole purpose is to move up and down an enemy's country, to make a whole region untenable, to crush down resistance offered by ordinary field fortifications. Mines will be planted to blow up the destroyer. Mines do not prevent a battleship from venturing upon the sea. Moreover, the maneuvering power of the land war machine will be such that it may change its course wilfully with such rapidity that a whole countryside would have to be blown up in order to affect it.

Imagine yourself standing at one front wheel of this machine. Comparatively you would be no bigger than a baby standing beside the driving wheel of a passenger locomotive. Far above you would be the maze of spokes constituting the latticed wheel. Perched midway between the two gigantic front wheels, as tall as many a moderate sized office building, would be the ship-shaped armored car for the engines and the crew. You reach it by means of an elevator resembling that in which miners rise from deep coal mines. Once in the car, you might fancy yourself in the engine room of a ship; there is no difference so far as general appearances go. With the commander you step into the conning-tower—a circular, armored chamber well forward, dominating the entire landscape.

The commander gives a signal. The machine moves. It gains headway. Soon it travels at express-train speed. A mile ahead is a densely wooded park. In a minute the machine reaches it. Does it stop or swerve? It plunges on. Trees are crunched as if they are mere weeds. You look back in the wake of the machine. It is as if a storm had laid low every poplar and elm. And yet the machine is not even scratched. An enemy village, occupied by enemy soldiers lies in front. The machine speeds on toward it. It reaches them. Houses are battered down as if they were made of paper. Wherever the weights that dangle down in front strike, wherever the wheels move, there is a rending and a crushing. And so, everything is leveled before the war machine—walls of earth or masonry, houses big and little, railway stations and signal bridges.



# Old Favorites Modernized and Made to Express



Active children are likely to tire of a hobby horse that does not really travel. This one is mounted on wheels like a tricycle, the pedal being fastened to the front wheel and the handlebars to the head of the horse



Pierrot will begin at one end of the parallel bars and turn somersaults all the way across to the other end and then back again



Give a little jerk to Bruin's chain and he will dance and perform the tricks of a real, live, lumbering circus bear

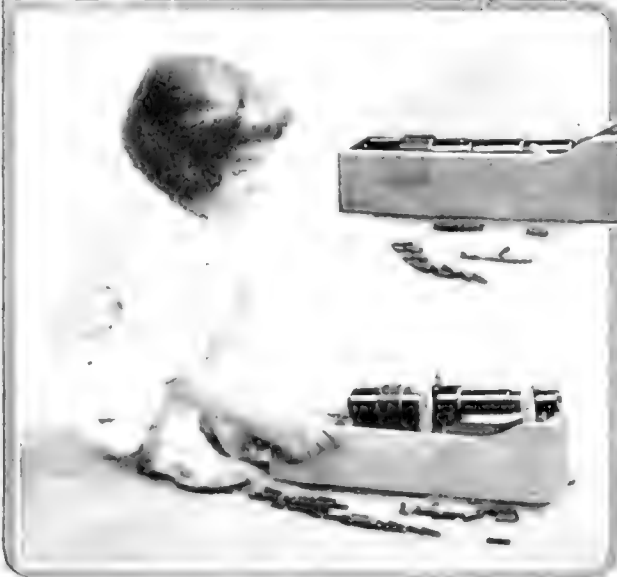

At left: A miniature gun which demolishes the enemy and then sinks down out of sight behind the breastworks. It is modeled after our disappearing coast defense guns

The toy phonograph below is so strongly constructed that even a destructive child could not readily get it out of gear. It will play regular records of larger machines or small ones

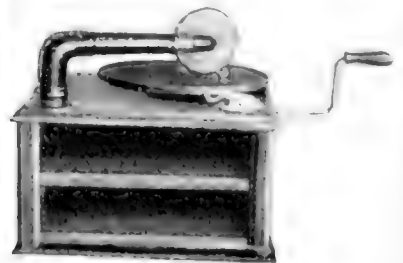

# Action Often Prove the Most Popular of Toys



This horse actually gallops. The four feet are mounted on wheels and the legs are lifted from the ground at each step



Pull the string, and the clown on the right above will toss the manikin clear over his head and catch it in his other hand

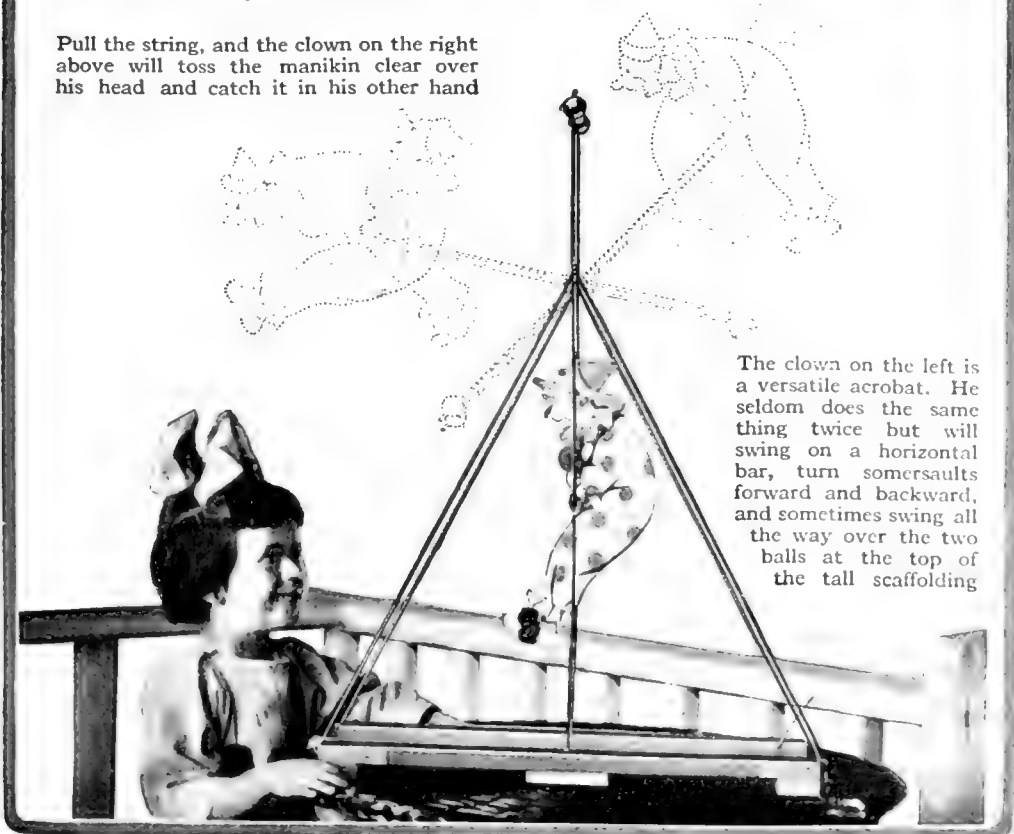

The clown on the left is a versatile acrobat. He seldom does the same thing twice but will swing on a horizontal bar, turn somersaults forward and backward, and sometimes swing all the way over the two balls at the top of the tall scaffolding

# How Inventors Are Meeting Young America's



When the handle of the toy above is pulled the three figures on the merry-go-round revolve

Under his Oriental robe the little Japanese carries a mechanism which enables him, when wound up, to walk sedately and draw after him the beautiful lady in the cart, who waves her hands about in a very animated fashion in appreciation of the ride



Place these two little figures on the edge of the table and tap the table. They will engage in a lively dance. Their action depends on a spring and ball bearings

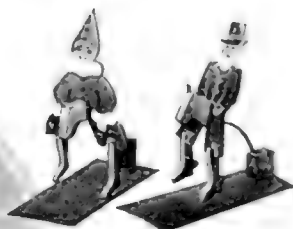

In oval below: When you take this little doll by the hand she will walk with you in a remarkably natural manner, provided you wind her up first.

She uses the joints both of her knees and her ankles



Below: A wheelbarrow which may be taken apart and put together again will teach the child the construction of the toy

Below: A sand cart equipped with a sifter and shovel. This cart, too, may be taken apart and may be packed away in the cart-body

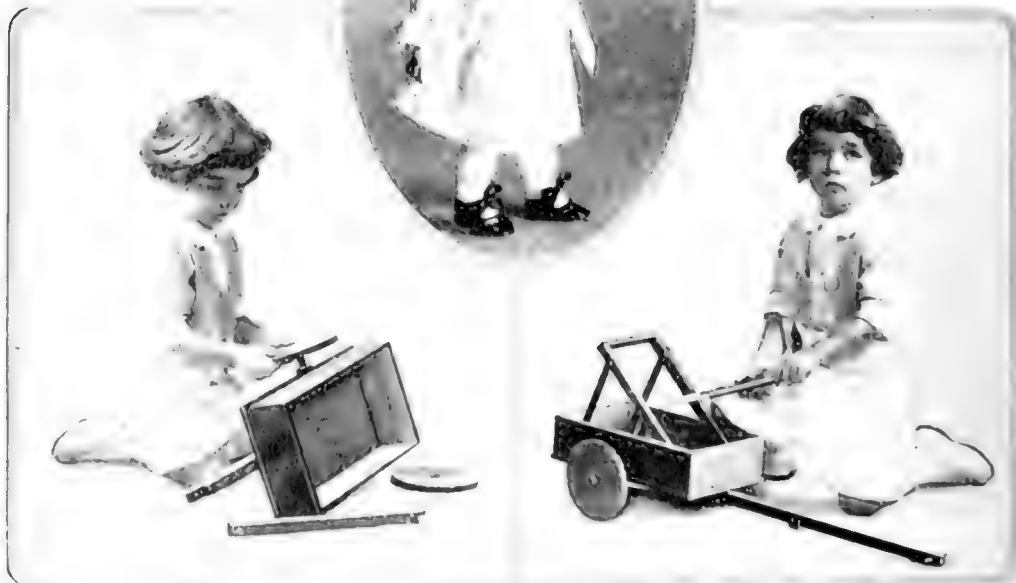

# Imperious Demand for a Variety of Animated Toys



The pairs of rockers on the front and the back legs of this charger move independently of each other and the horse can be made to travel all around a room

The little dachshund below will be so pleased to follow where his master may lead him that he will wag his tail and wiggle all over. He moves on ball bearings

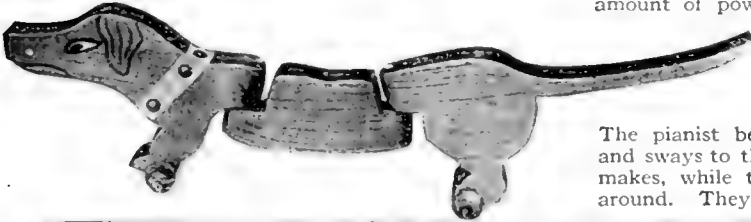

A toy outfit which teaches the A, B, C of electricity. The motor can be taken apart and reassembled and will furnish a small amount of power to operate other toys

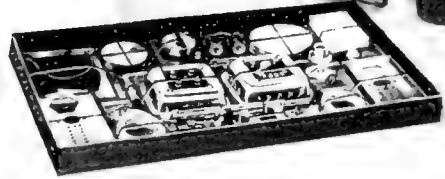

The pianist below shrugs his shoulders and sways to the rhythm of the music he makes, while the dancers waltz merrily around. They are operated by springs



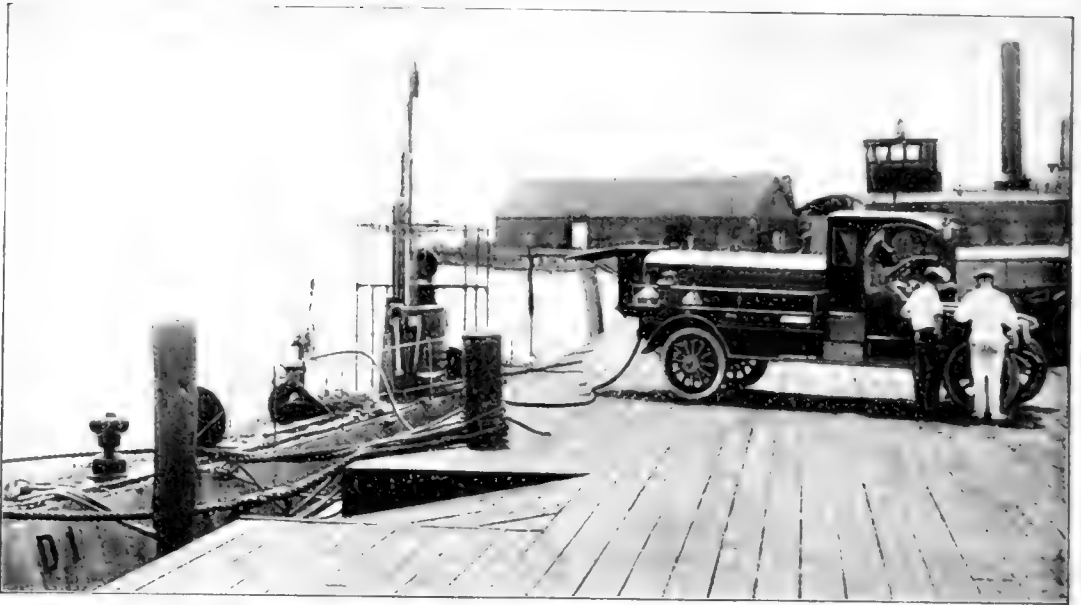

A tank truck at the dock at New London, Conn., delivering fuel to the United States submarine D-1, shortly before the submersible left port to participate in the maneuvers of the Atlantic Squadron

### Gasoline Tank-Trucks as Tenders to Our Submarines

**L**ARGE fleets of tank trucks operated by the various oil companies are proving valuable adjuncts to the United States Navy in supplying oils and gasoline to submarines, hydroplanes and other types of naval vessels along the Atlantic and Pacific coasts.

The speed of the trucks is important in delivering vast quantities of fuel, thus making it unnecessary for naval craft to lie at the docks for long periods awaiting the arrival of these highly essential supplies. The great capacities of the tank trucks permit the oil companies to deliver large quantities of oil and gasoline in one haul. On arriving at the dock, a long section of rubber hose is used to transfer the load direct to the fuel compartments of the vessel.

The accompanying photograph shows a tank truck at the dock in New London, Conn., delivering fuel to the United States submarine D-1 shortly before the submersible left port to participate in the naval pageant and maneuvers of the Atlantic Squadron.

### Preaching the Gospel from an Automobile on the way from San Diego to Sweden

**N**ELS THOMPSON, now an evangelist but formerly, as he says in his sermons, a follower of the race tracks, is bound from San Diego to Sweden, in the land-yacht church shown in the illustration. Thompson built the body, painted it and decorated it with religious texts. Then he purchased a two and one half ton chassis, mounted his church-home upon it, and started for San Diego. After holding revival services there he set out across the mountains to San Bernardino and thence eastward into the desert for a cross-country tour. On reaching the Atlantic coast he plans to ship his car to Sweden where he will resume his work.

Distillate, a petroleum product lower in grade than gasoline, is used for fuel.

It costs about nine cents a gallon in the west. A distillate-burning range inside the truck draws its fuel from the same tank which feeds the engine.

Mr. Thompson does his own driving and makes his own repairs on the trip. His family travels with him in perfectly comfortable style.

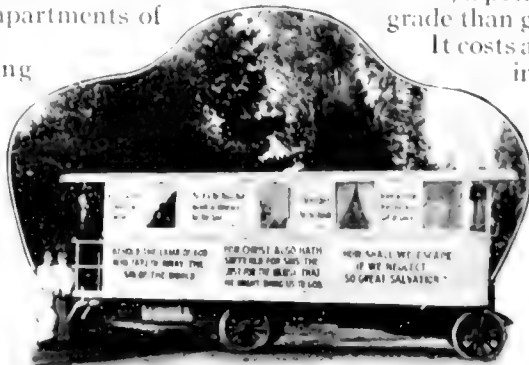

The evangelist does his preaching from the platform of the truck. The interior is a cosy home

**An Artistic Grocery Store in a Residential District**

RESIDENTS of an exclusive suburban district in Portland, Oregon, objected strenuously when a grocer announced that he was going to build and conduct an establishment in their locality. Citizens even went so far as to invoke the law in their behalf, but they were overruled.

Now the building is finished and open for business, and those who were most opposed to it can but admit that so far as exterior appearances go, it gives no cause for complaint. An inconspicuous sign is all that indicates the nature of the building.

It is a one-story colonial style stucco structure, set back thirty feet from the sidewalk. Broad cement walks lead from the sidewalk to the front veranda of the store.

The windows are artistically curtained. Inside, groceries are displayed on shelves built like stairs, but there is a large fireplace to preserve the home-like effect.

No goods are delivered through the front door. A concrete walk also leads from the rear door to the sidewalk, so that the impression of a residence is maintained.

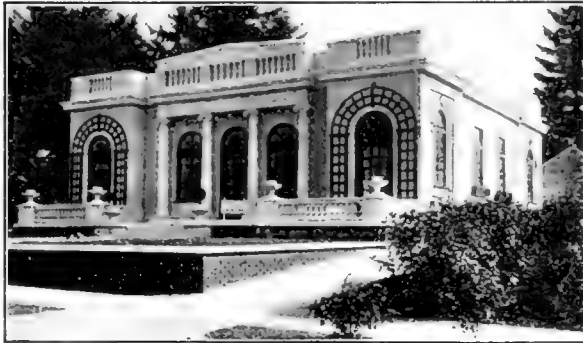

The grocery store as a fashionable dwelling-house. An inconspicuous sign is all that denotes its character

pulling of an automobile by an ostrich. This test or performance came as a result of a discussion between the proprietor of one of the largest ostrich farms near Los Angeles, California, and a number of automobile men of that city. The farm proprietor claimed that the bird could pull the car. The automobile men doubted but they were ready and waiting to be convinced.

Several days later an Inter-State touring car was secured and run out to a boulevard close to the ostrich farm. One of the largest birds, with a sack over its head, was led through the farm-gate and immediately hitched to the front axle of the automobile by means of an especially prepared set of harness.

The trainer took his position upon the back of the bird and urged it forward, but just as soon as the traces became tight the ostrich balked and danced around. After repeated efforts had been unsuccessful in getting the bird to pull, the trainer thought he would try a different method. Suddenly he reached up and took the sack from off the bird's head and again urged it forward. The ostrich, upon seeing what was really expected of it, tightened the traces and kept on pulling, with the result that the car began to move, and continued, though slowly, until the bird was

told to stop. To add to the difficulties of the test, the machine was headed up a slight grade. After being unhitched the ostrich walked slowly back into the farm yard amid the cheers of the spectators. The test was a demonstration of the intelligence of the bird, also, which has not been rated particularly high.

**Testing the Pulling Power of an Ostrich**

NOW and then we hear of unusual "stunts" being performed in connection with an automobile, but it is probable that nothing more novel has been reported during recent months than is illustrated in the accompanying photograph—the

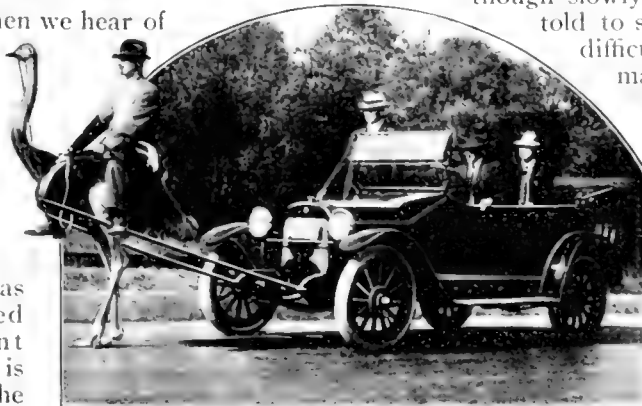

The ostrich sustained the weight of the driver and pulled the automobile uphill until told to stop

# Studying the Stars with Mirrors

The biggest reflecting telescope in the world belongs to Canada

By Dr. C. Furness

*Professor of Astronomy in Vassar College*

IT IS with the reflecting telescope that many of the most brilliant discoveries about stars are made. Its construction, however, is not so generally understood as that of the refracting telescope, the form of instrument which is so often seen in the parks or on the streets of our cities and through which the passerby can get a peep at the Moon for the trifling sum of five or ten cents. By calling attention first to certain facts regarding this more familiar type of telescope, it will be easier to make clear the construction of the reflecting telescope.

The lens at the upper end of a refracting telescope is called the object glass. It collects the rays of light and brings them together at a focus to form an image, which is viewed with a magnifying eyepiece. The largest refracting telescope is the well-known Yerkes instrument. It has an object glass forty inches in diameter.

In a reflecting telescope, the light is collected by reflection from the surface of a concave mirror. If this surface is ground to a parabolic shape, the rays will all come together at a single point to form an image, just as with the refracting telescope; but this point will be situated on the same side of the mirror as the object, and hence the observer who tries to look at a star will find his head in his own line of vision. In order to overcome this difficulty, a second reflection is made to take place, so as to

deflect the beam of light and form the image at one side of the tube, where it may easily be examined with an eyepiece. This second reflection is accomplished by means of a plane mirror or "flat" inserted in the upper end of the tube and set at an angle of  $45^\circ$ . This flat will necessarily cut off some of the light falling upon the principal mirror, but since it is not large and since its supports are made as slender as possible, there is no serious loss.

## *A Mirror Six Feet in Diameter*

At first mirrors were made of speculum metal, an alloy of copper and tin, which can be very highly polished. As early as 1842, the famous reflector of Lord Rosse was constructed. It had a mirror six feet in diameter. With this instrument many drawings of nebulae and planets were made. However, it never attained the usefulness which might have been expected, chiefly on

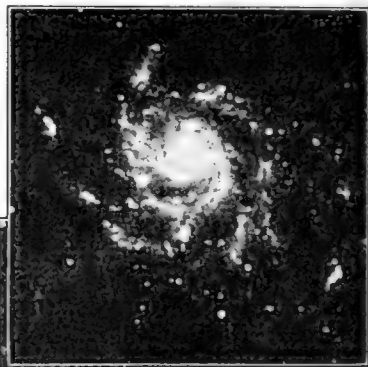
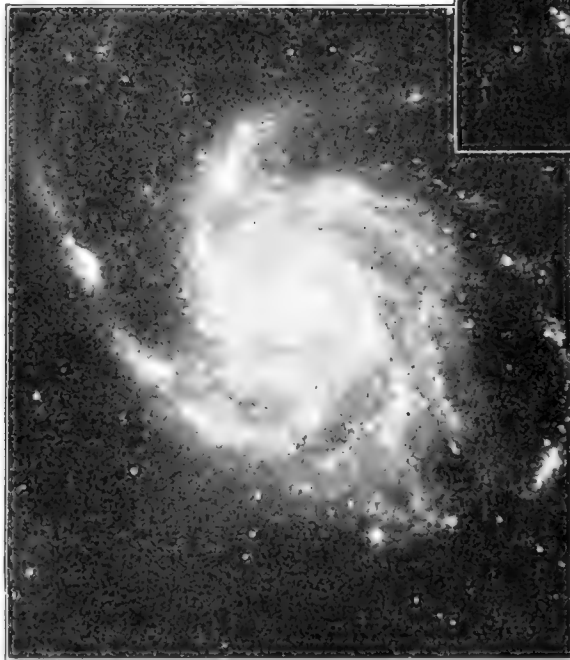

Above: Spiral nebula Messier 101, Ursa Majoris, photographed with the two-foot reflector of the Yerkes Observatory. Time of exposure, three hours

Another photograph of the same nebula, taken with the sixty-inch reflector of the Mt. Wilson Solar Observatory. Time of exposure, seven hours, thirty minutes. Comparison shows the greater detail in the lower photograph



account of its unwieldiness. Mechanical appliances for supporting and moving heavy apparatus had not reached the perfection of the present day, and the six-foot telescope of Lord Rosse could not be moved more than ten degrees either side of the meridian.

On account of these difficulties, interest in the reflector lapsed, except in England, where it has always been a favorite. With the development of photography and its application to astronomy, its usefulness became very apparent. Within the last few decades, therefore, several large reflectors have been built. They are no longer made of speculum metal, but of glass, on the front surface of which a thin film of silver is chemically deposited.

### *Different Types of Reflectors*

In this country there are several large reflectors, some of which are famous for the work which has been done with them. Thus, there is the Crossley three-foot reflector at the Lick Observatory, which was used by Prof. Keeler in photographing nebulae. The results of his labors showed that a very large number of nebulae have the spiral form shown in the accompanying illustrations. The Crossley instrument, however, was not of American origin. It was made in England and presented to Lick by its owner. Its installation was followed by the constructing and mounting of the two-foot reflector of the Yerkes Observatory, under the direction of G. W. Ritchey, who also made the mirror for the great sixty-inch instrument on Mt. Wilson and designed its mounting. A comparison of the two photographs of the same nebula (Messier 101 in Ursa Major), on the preceding page, taken with the two instruments, shows that both of them give beautiful results, but that the larger instrument has a greater wealth of detail.

There is a forty-inch reflector at the Lowell Observatory in Flagstaff, Arizona, and two others are in process of construction—a hundred-inch for the Mt. Wilson Solar Observatory and a seventy-two-inch for the Dominion Observatory of Canada which is to be installed at Victoria in British Columbia.

The principles of construction are the same, whatever the size of the instrument, but the great weight of a large reflector makes the engineering problem a difficult one. The building of the seventy-two-inch Canadian instrument may be taken as an

illustration of some of the mechanical difficulties to be surmounted, and the accompanying pictures have been selected to show different stages in its progress. One shows the mounting as it was set up in the workshop in Cleveland. The ends of the polar axis AA' are supported on steel castings which are bolted to the heads of concrete piers. The permanent pier erected at Victoria is shown also. The polar axis must be set parallel to the axis of rotation of the earth. In the latitude of Victoria it makes an angle of more than  $48^\circ$  with the horizon. To the uprights of the framework of the walls are attached horizontal ribs which are for the purpose of supporting the sheet metal walls. It will be noticed that they are in pairs, being fastened both to the inner and the outer edges of the upright beams. The sheathing is attached to both sets, forming thus a double wall, with an intermediate air space of at least six inches. This structure must be made extremely stout in order to bear the enormous weight of the dome. One of the pictures shows the building complete, up to the covering of the dome. This is furnished with a system of shutters which with the double wall permit the interior of the building to maintain an even and moderate temperature. Electric motors are used in moving the telescope and dome. These are controlled by push buttons, located on small keyboards conveniently placed for the observer to use. An important part of the gearing is the clockwork, which carries the telescope with the rotation of the heavens, so that a star can be kept in the field of view as long as is desired. This must be made so that the telescope moves with absolute steadiness.

The optical parts of the instrument are being made by Brashear at Allegheny. The large mirror is twelve inches thick at the edges and will weigh over four thousand pounds.

### *What Good is a Reflecting Telescope?*

Having thus given somewhat in detail the construction of the reflecting telescope, it remains to describe the work which can most satisfactorily be done with it. First, it is used for direct photography, both for recording very faint objects and for getting fine details of brighter objects, such as nebulae. This is perhaps the use which appeals most directly to the general reader. We can also get the photographic images of very faint stars, the twentieth magnitude

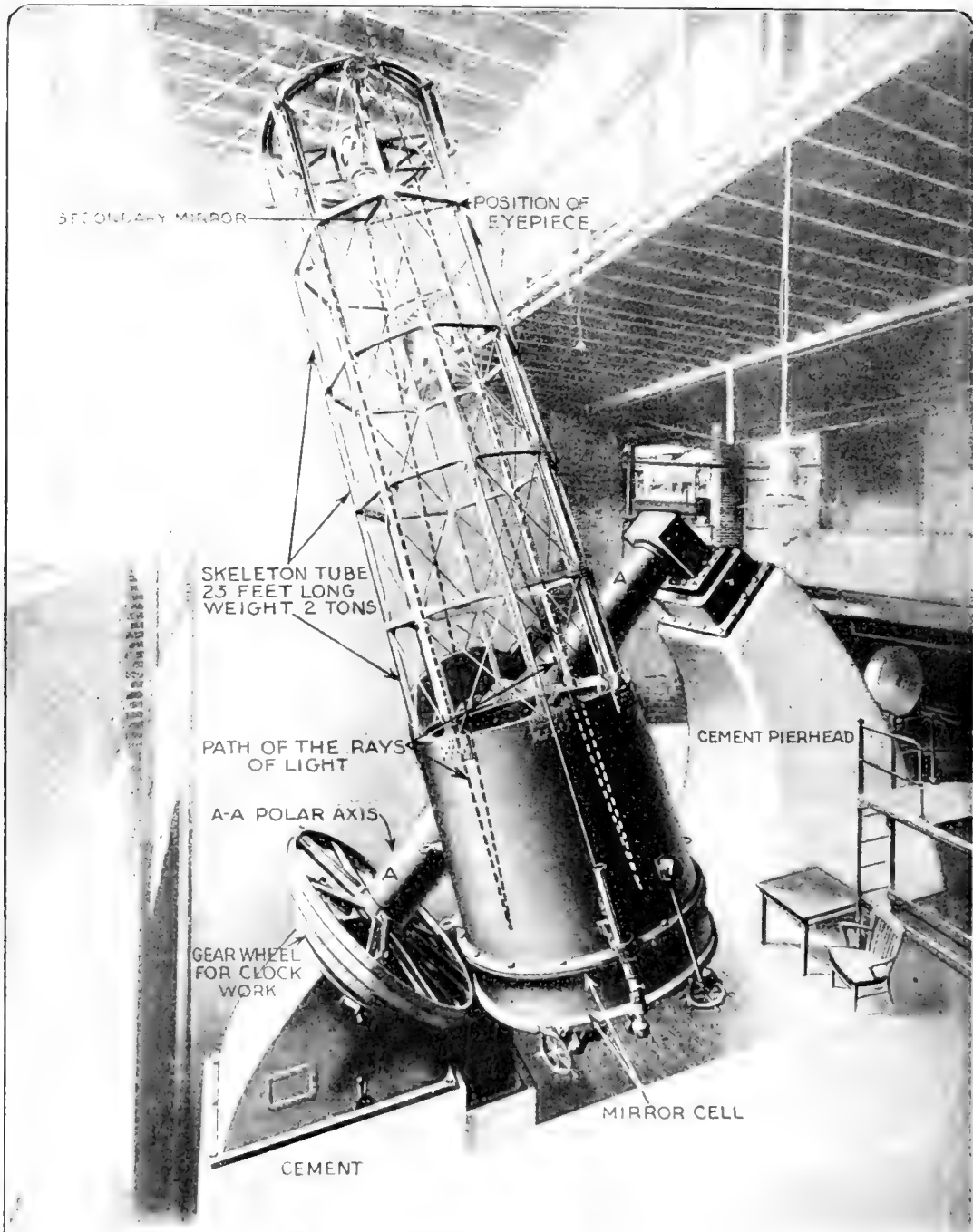

Mounting of the seventy-two-inch reflector of the Dominion Observatory of Canada, to be installed at Victoria, British Columbia. The principles of construction are the same whatever the size of the instrument, but the great weight of a large reflector makes the engineering problem a difficult one. The weight of the mirror cell with the mirror is six tons. The polar axis which is bolted to the pierheads, weighs ten tons. The skeleton tube weighs two tons. The dotted lines represent the path of the rays of light. The polar axis must be set parallel to the axis of rotation of the earth. In the latitude of Victoria, it makes an angle of more than forty-eight degrees with the horizon

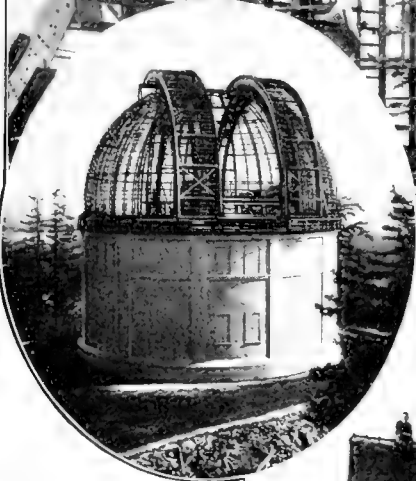
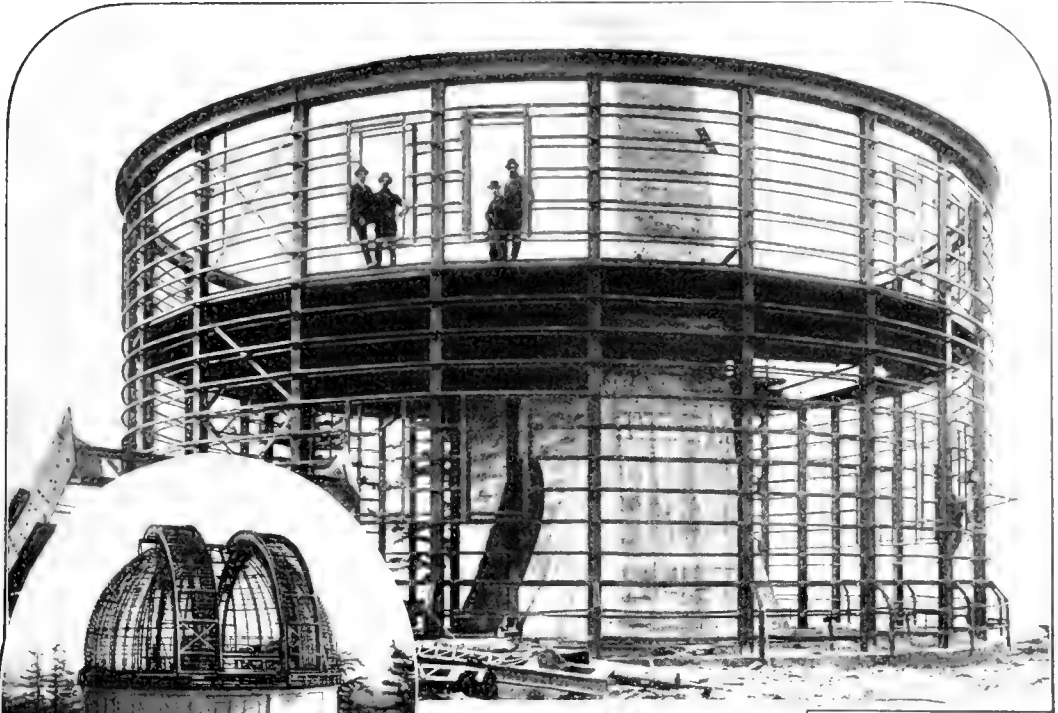

Above: The building complete, up to the covering of the dome. This is furnished with a system of shutters which with the double wall permit an even temperature to be maintained in the interior of the building

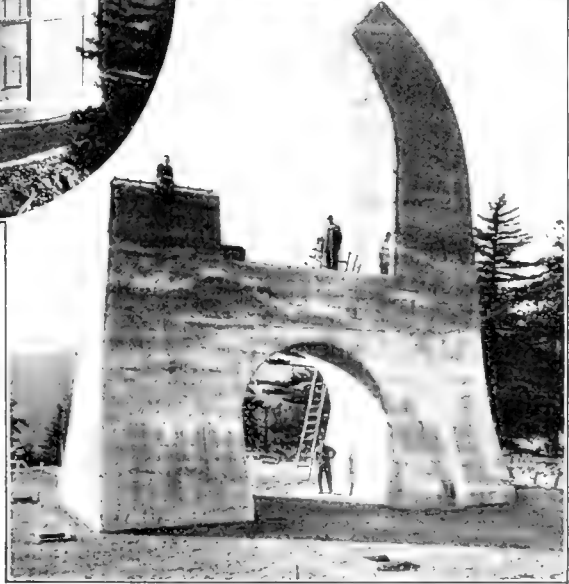

Above: The iron framework of the walls. Horizontal ribs are attached in pairs both to the outer and inner edges of the upright beams, thus forming a double wall with an intermediate air-space

The permanent concrete pier at Victoria. The ends of the polar axis are supported on steel castings which are bolted to the heads of the piers

having already been captured. It is also extremely valuable for spectroscopic work. A long exposure is required even with the great forty-inch Yerkes refractor to obtain the spectrogram of a star of the fourth magnitude. This is much reduced at Mt. Wilson by using the short focus sixty-inch mirror, not only on account of the larger size, but also because the loss of light caused by reflection is much less than that

suffered by a ray of light in passing through the thick lenses of a large refractor. Recently, a great deal of attention has been paid to the study of the spectra of nebulae, and some extraordinary results have been obtained. It has been found that some of them show evidences of rotation, a most important fact in its bearing on the evolution of star systems, if it can be established by photography.



Several tons of stones were used to insure the safety of these henhouses. Care was taken to place the stones directly above the roof supports of the partitions to prevent sagging

### Anchoring the Henhouse in Cyclone Districts

A RANCHER in Southern California had been troubled by the severe windstorms of that section, which threatened to wreck his henhouses. Finally he thought of weighting down the roofs with large boulders weighing from thirty to fifty pounds. He was careful to place them directly above the roof supports, that is above the four walls and the partitions.

### A British Motor-Bus Run on Ordinary Coal Gas

THE scarcity of gasoline in England and its consequent high price has caused the owner of the motor-bus, shown in the accompanying illustration, to use ordinary coal gas to drive it. This is new in application yet old in principle. Many American automobile manufacturers have used coal gas to test their motors, because it is considerably cheaper than gasoline now.

The special feature of the method illustrated here is that the gas is carried under low pressure in a large bag strapped to the roof of the 'bus, instead of in steel cylinders at high pressure. This eliminates the cost of compressing the gas and enables it to be fed into the bag direct from the town supply

tank line anywhere along the route.

A flexible pipe is used to convey the gas from the bag to the engine intake manifold just above the throttle, the function of the carbureter being eliminated, except to provide a sufficient amount of air to mix with the gas fuel. An ordinary cock, placed in the gas line close to the motor and directly coupled to the throttle-valve lever, controls the supply in accordance with the engine speed.

The gas bag, a simple canvas sack with a rubber insertion, does not offer much head resistance, because it gives with the wind and presents a streamline form. It holds four hundred and fifty cubic feet of gas, which is sufficient to drive the 'bus for twelve miles without refilling. It is said that by test the cost of gas fuel for the 'bus is but one cent a mile, while with gasoline it is six cents per mile.

Many other tests of ordinary town gas for running automobiles have been made both here and in England. A Glasgow

resident ran his automobile on ordinary town gas by removing the jet nozzle of the gasoline carbureter and substituting a grilled plate. This

was done to break up the flow of gas and to enable the air to mix with it properly. A lever

on the steering wheel controlled the amount of gas.

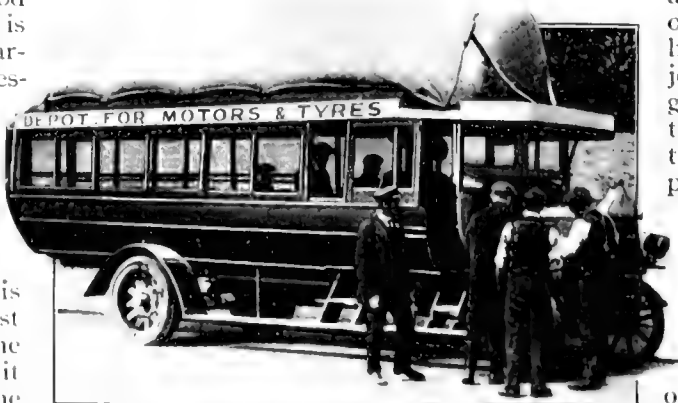

The gas is carried under low pressure in a large bag strapped to the roof of the 'bus

**Determining the Intensity of Illumination by a New Measuring System**

A NEW and convenient type of instrument for the measurement of light has been developed by Norman Macbeth, illuminating engineer. It differs from the photometer, an instrument somewhat similar, only in the details of its construction and in that its scale is calibrated to read in foot-candles. But the method of its use is different.

To measure illumination intensities a test-plate, made of white material of good diffusing qualities, is placed at the point in the plane where the illumination value is desired. It becomes a secondary source of light, the brightness of which is compared with that of a translucent screen, the measuring instrument of which is illuminated to a known intensity by a small tungsten lamp.

The intensity of any source of illumination may be determined by placing the test-plate a known distance from the source, measuring the illumination-intensity in foot-candles upon the test-plate and then computing the candlepower by multiplying the scale values by the square of the distance of the test-plate from the unknown source (the law of inverse squares).

The scale is calibrated in foot-candles and the readings give the intensity of illumination at a given point.

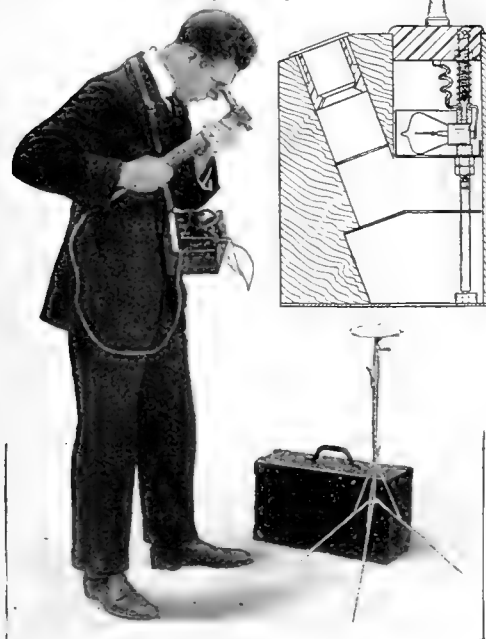

The lamp carriage is moved up and down in the tube by means of a rack and pinion operating upon a brass rod

The aperture opposite the telescope is pointed toward the test-plate or any surface whose brightness is to be measured

**Deflecting and Moistening the Air from Furnace Registers**

UNTIL we substituted the modern hot-air furnace for the stove we did not know what a completely warmed house was during the winter months. But evil accompanies good. The heated air from the furnace is too dry for good health and perfect comfort, and as an additional worry, the walls at the sides and above the registers soon become discolored by the blackened dust which rises and disperses through the rooms of the house whenever the ashes are shaken down or the furnace cleaned.

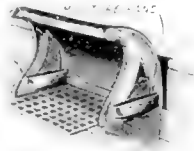

The registers are provided with water-pans to moisten the air

To obviate these troubles a register-shield has been placed on the market, which may be inserted over either floor or wall registers. These metal shields deflect the rising stream of hot air and direct it out into the room instead of allowing it to go directly toward the ceiling, as it otherwise would. The shields are also provided with water-pans which are kept warm by the air from the furnace. The water evaporates and moistens the air as it passes through the shield.

**Removing Old Starch from Clothes by a Malt Extract Bath**

AS starch is insoluble in water it has always been a hard problem of the laundryman to remove it from soiled collars, lace curtains or other articles which are either heavily starched or made from delicate material.

Strong, hot alkaline baths and long rubbing or pounding have been the principal resort, although they shorten the life of the fabrics, destroying wool fibers, shrinking cotton and spoiling colors.

Modern laundries are beginning to introduce the malt extract bath as a substitute for the alkalis in laundries. Malt is a chemical compound having the property of converting starches or starchy foods into soluble dextrine or glucose. It requires only four ounces of malt extract to remove the old starch from one hundred collars or an equivalent amount of goods, and it is not affected by hard water.

# A Motor-Driven Brake

The pressure of a finger stops the car

**T**HE manual labor usually required for the handbrakes of a motor vehicle is avoided by an electric brake requiring only the pressure of one finger to operate it. The device consists of a small electric motor which drives a tiny drum carrying a steel cable attached to the brake-equalizer and to the regular brake-drums. The motor is controlled from the steering-wheel column.

The motor with its drum can be located under the body, under the driver's seat or under the motor-hood, as shown in the accompanying illustration. It takes up very little space, since it is only four inches high, six inches wide and eight inches long. It can be attached to any car simply by substituting it for the usual hand-levers, lever quadrant and brake-rod connections.

The controller consists of a two-point switch enclosed in a small housing bolted to the steering-wheel column directly beneath the wheel, within easy reach of the driver's hand. A simple movement of the switch-handle controls the brake throughout its entire range of operation, thus making it very easy for a woman to drive even the heaviest of

cars. The manual labor in braking is analogous to that of cranking the motor, which was done away with by the electric starter, so that the ultimate general application of some form of mechanical brake is practically assured.

The electric brake draws its operating power from the regular vehicle battery which may be of 6, 12 or 24 volts. The current consumed is said to be very slight.

The device contains several novel mechanical features, the total reduction from the brake-motor to the

drum carrying the brake-cable being four hundred to one. This is secured by means of a non-reversible worm-gear on the armature-shaft which drives another gear in mesh with an internal-toothed gear on the cable-drum. Between the drum and the worm-gear is an adjustable friction-clutch by means of which sufficient pressure is secured to transmit the maximum braking effect, but beyond which, it will slip. After a thousand-pound pull has been exerted on the cable, the slipping clutch comes into play, preventing any further pull, while a ratchet keeps the brake from slipping off.

Because of the powerful



The brake-motor is controlled from the steering-wheel column by simply moving a switch-handle



Diagram showing controller and the power connection

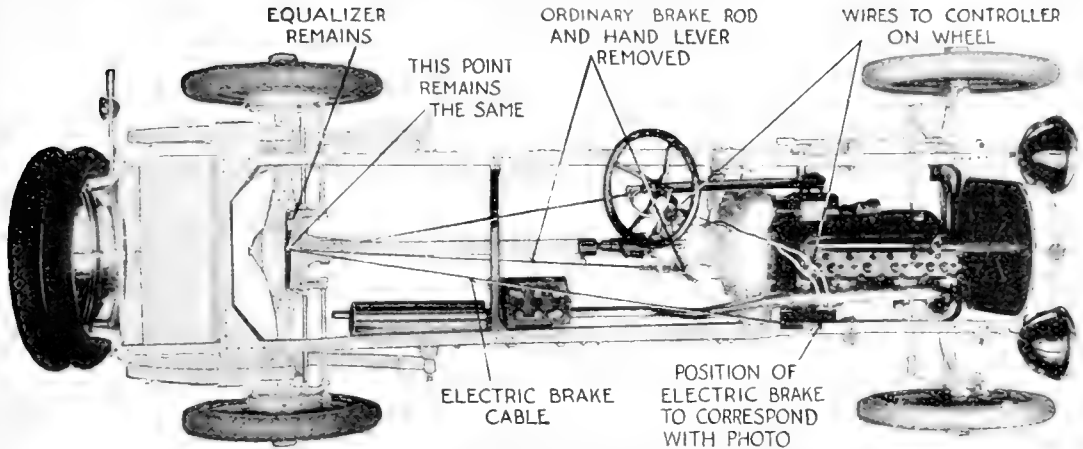

The motor can be attached to any make of automobile simply by substituting it for the usual hand-levers, lever quadrant and brake connections. The brake is disengaged by pushing the switch-handle back to its original position. The device weighs twenty-five pounds

pull on the brake-cable, it has been found feasible to have the brake-drums run in oil, reversing the usual practice which is to keep them as dry as possible.

By means of the two-point switch-controller, the electrical energy is so governed that the brake can be applied gradually or in the fraction of a second in an emergency. The first-point switch position supplies enough braking power for service purposes and the second for an emergency stop.

**A Device for Adjusting the Ends of Steel Rails**

**A** RAILROAD man of Louisiana has invented a device for adjusting rails, which is employed at the rail-ends where space is allowed for expansion and contraction.

Two strong clamps are provided, one of which is fitted over each end of the adjoining rails. A double-threaded screw connects them. Over this a rod is fitted, by means of which the screw is turned to spread the rails or draw them together as desired.



One of the clamps fits over each rail-end and a screw-rod spreads or joins them

**Wire Wheels for Automobiles Are Rapidly Taking the Place of Wood**

**O**NE of the most interesting tendencies of the times in the automobile-manufacturing business is the growing popularity of the wire wheel. An examination of the statistics of wheel production in this country reveals the fact that a distinct wire wheel boom is under way and is rapidly gaining momentum. At the end of 1915 it was estimated that there were not more than ten thousand cars equipped with wire wheels. The 1916 season, though not yet finished, has probably added fifty or even sixty thousand cars to this class, a gain of five hundred per cent. With that spectacular increase in mind it is not difficult to credit well-informed automobile men who predict that 1917 will see two hundred thousand new cars put on wire wheels. These wheels are popular on account of their handsome appearance; and they have received an impetus from the scarcity of hickory of the best quality, and from the patent litigation which has vexed the manufacturers of the demountable rim.



# Producing the Coldest Cold

Think of 400 degrees below zero!

Think of gases that have been squeezed and cooled until they look like water!



Burning a piece of cold-rolled steel in liquid air. The liquefied oxygen combines so rapidly with the metal that a furious heat is produced

At right: By using a vacuum pump the rate of evaporation can be increased enough to freeze the air contacting the outside of the tube

AMONG the more startling discoveries of the past decade is the production of temperatures reaching as far as  $400^{\circ}$  F. below zero. It is the attainment of these low temperatures that has brought the chemist and physicist into a new world; for when matter is subjected to such degrees of cold, there is a complete alteration of both its chemical and physical properties.

Each substance on our earth has individual properties, both chemical and physical, which it can retain only at a specific temperature—a temperature

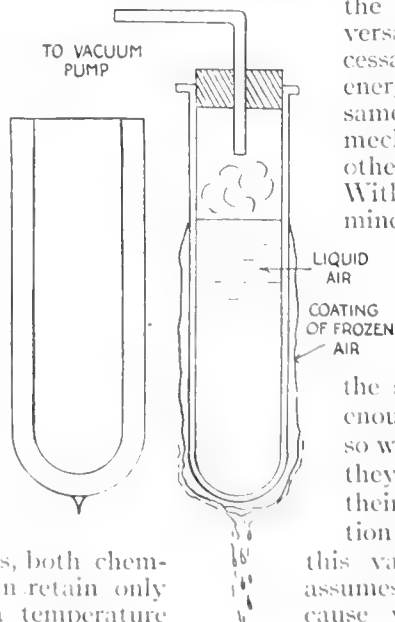

which nature set for it. If we alter this temperature by artificial means the substance will gradually assume a different physical state. This change of state is "forced" upon it, and when we withdraw the artificial means of changing its temperature, nature promptly transforms the substance into its original state. As an example, water at ordinary temperature is a liquid. If we heat it to  $212^{\circ}$  F. it becomes steam, and if we cool it to  $32^{\circ}$  F. it becomes a solid.

What is known as the kinetic theory of matter tells us that all molecules are in perpetual vibration at a tremendous velocity and are continually colliding with one another. This rate of molecular vibration produces the temperature of matter—the higher the rate of motion the greater

the temperature and vice versa. The molecules are incessantly giving out their energy of motion and at the same time are receiving these mechanical impulses from other particles of matter. With these simple facts in mind, we may continue more intelligently.

When we boil water we merely impart energy in the form of heat to the molecules. If the source of heat is intense enough, the particles become so wild in their vibration that they come out of the range of their natural mutual attraction and pass off as vapor. If this vapor is cooled it again assumes the liquid state, because we have taken energy

from the molecules and have caused them to return to their natural degree of vibration. If we continue to cool the liquid, we still further paralyze the motion of the molecules, until they become so crowded together that we have a solid—ice.

### To Change a Gas into a Liquid—Cool It

Now, then, in the light of the knowledge imparted in the foregoing paragraphs, if we wish to change a gas to a liquid we must cool it. This is true. If sulphur dioxide (a gas obtained by burning sulphur) is cooled to a few degrees below zero, it condenses into a liquid. As soon as the artificial means of

The tin cup on the right was frozen by immersion in liquid air, after which it was easily broken

cooling the gas is withdrawn, it rapidly assumes its natural state, as gas, by evaporation.\* Now to get back to its natural state it needs a specific amount of heat to make its molecules vibrate at a definite rate, that which nature determined. Where does it get this heat? It abstracts it from its surroundings so rapidly that a still further degree of coldness is realized as the gas is formed from the liquid and passes off carrying with it its natural amount of heat which it has greedily robbed from material in contact with it. For commercial purposes liquid carbon dioxide is stored under great pressure in durable steel cylinders. If the jet on the cylinder is opened, the liquid evaporates so rapidly that the temperature of the container is soon lowered far below zero, and a solid



Part of condenser in a laboratory refrigerating apparatus. The chamber is so cold that frost is formed. Yet liquid air would boil briskly if placed on the tubes

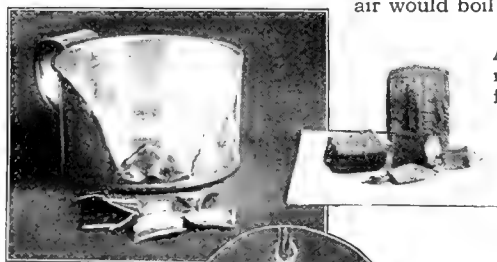

At left: What remains of a large rubber cork after it has been frozen and struck with a hammer

At left below: Two screweyes frozen into a block of mercury so solidly that they sustain the weight of two flatirons suspended from a great height

formation of carbon dioxide appears on the mouth of the jet.

Professor Dewar liquefied hydrogen and helium in the laboratory of the Royal Society by a different method from that of rapid evaporation. The principle applied by him is based on the fact that a compressed gas allowed to expand freely greatly lowers its own temperature. Lord Kelvin made known this fact early in his career, and it was commercially utilized by Linde, a German scientist, and by Hampson, an English physician. Both workers were laboring independently of each other.

\*This is assuming that the gas is not stored under pressure, which prevents evaporation.

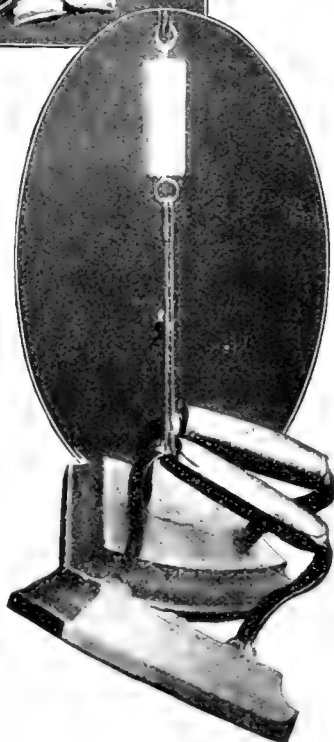

*How Expansion Cools*

It was found that if the compressed gas was allowed to expand through a small opening its temperature was still further lowered.

Working with these facts in mind, Linde and Hampson perfected a process by which they were able not only to obtain far lower temperatures than with the old evaporative method, but to liquefy gases that had hitherto resisted all efforts. The apparatus used consists of a coil of pipe (see diagram) through which the compressed gas is permitted to pass and expand through a small opening at the end. First, the air is brought to a pressure of 200 atmospheres by means of the compressor. It is discharged from this through the valve *N* and into the water-cooled jacket *C* where the heat of compression is abstracted. From there it flows through the smaller coiled pipe which is concentrically arranged within the larger one. As the air reaches the expansion valve *H*, and flows into the heat-insulated chamber *E*, its temperature is greatly lowered. The cooled air then rushes back through the larger pipe and lowers the temperature of the succeeding air coming through the smaller pipe. It will be seen, then, that the air emanating at *H* will gradually become colder until a liquid state is reached.

Dr. Hampson's apparatus for the liquefaction of gaseous matter was designed with such ingenuity and constructed so perfectly that compressed air at ordinary temperatures passed through the coil came out as a

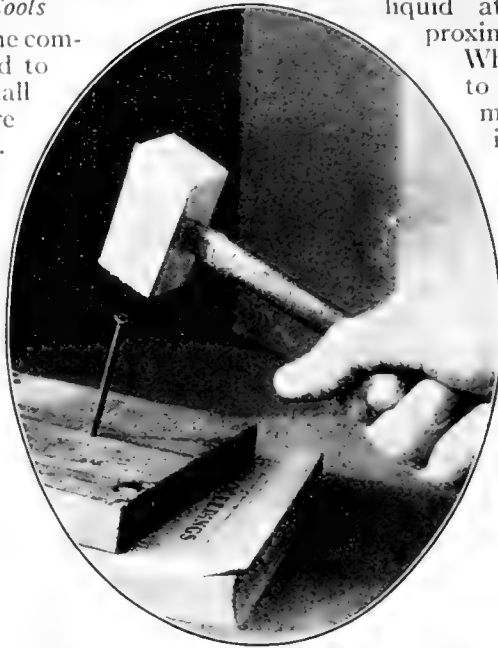

Driving a nail with a hammer made of mercury frozen solid by immersion in liquid air

liquid at the nozzle in approximately six minutes.

When attempts were made to liquefy hydrogen by this means, it was found that instead of being cooled by expansion its temperature was actually raised. Later it was discovered that hydrogen obeyed this law only when its substance was first cooled by contact with some refrigerating medium. In the apparatus employed to-day for the liquefaction of hydrogen, the gas is first reduced to a low temperature by means of solid carbonic acid and liquid air. By this means, Dewar also brought helium to a liquid state.

*Gases That Look Like Water*

The fact that these liquid gases cannot be kept in ordinary containers should be readily appreciated by the reader when it is understood how rapidly they abstract heat from their surroundings. If liquid air is poured into an ordinary glass vessel it immediately starts to boil and will reduce the container to bits. It must be remembered that liquid air has a boiling point about 180° Centigrade below zero. If liquid gases, then, are to be kept any length of time they

must in some way be insulated from the heat of their surroundings. It has been known for a long time that nothing but tangible matter will conduct heat waves. Dewar ingeniously took advantage of this fact in a method by means of which he can preserve liquid gases over a considerable period of time. He uses a glass vessel with two walls between which a high vacuum prevails. If a small

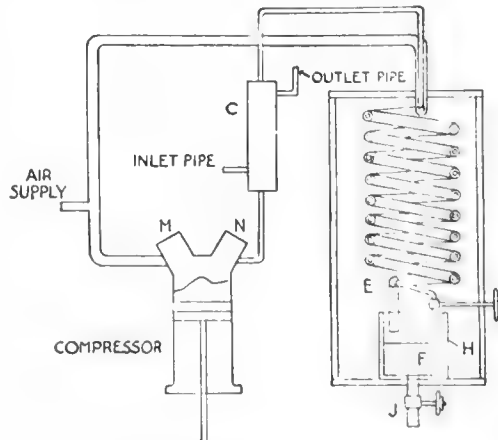

Diagram explaining the apparatus used in the Linde process for the liquefaction of gases

amount of mercury vapor is left between the walls, it will be solidified and deposited upon the walls of the vessel upon the entrance of a liquid gas. In this manner it acts as a mirror and reflects heat waves that impinge upon the outer surface of the container. Thus was the familiar commercial vacuum bottle created.

Now that the methods for producing low temperatures have been explained, we will briefly review some of the more wonderful phenomena that occur when matter is subjected to such severe low temperatures.

### *Strange Things That Happen When Gases Are Liquefied*

If a piece of silver forming part of an electrical circuit is immersed in liquid air and held there, it undergoes a physical modification that reduces its electrical resistivity to an almost unnoticeable amount. It was predicted by physicists that at absolute zero a metallic substance would offer no resistance to an electrical current.

Professor Dewar discovered that if a magnet was repeatedly immersed in liquid air, its magnetic influence was not only intensified but permanently increased. Also, curiously enough, oxygen may be separated from the nitrogen in liquid air by magnetic means.

A student of physics would naturally ask: Will a liquid gas alter the color or light-absorption of a substance? The answer is, yes. Understanding, as we do, that the color of a substance depends upon the wavelength of the ether waves of the spectrum it absorbs, it would be natural and tempting for one to conclude that it was the great contraction of the molecules that affected its wave absorption at this temperature. We must be more cautious than positive in making this pretty assertion as final at this time. It has been found, however, that at these low tempera-

tures red things become yellow and yellow things white and so on.

It has been found that if a bell constructed of pure lead is subjected to such a low temperature, it has a pure metallic ring when struck a sharp blow. Bits of vegetable matter immersed in liquid air become so hard and brittle that they may be powdered in a mortar. In the laboratory of the British Royal Society, it was found that the bacteria could not be destroyed even by the lowest temperatures.

The "absolute zero" has been set by physicists as being  $273^{\circ}$  Centigrade below zero ( $459.4^{\circ}$  Fahrenheit below zero). In this condition matter will have absolutely no heat. The nearest approach to this has been in the liquefaction of hydrogen or  $-254^{\circ}$  Centigrade ( $-425.2^{\circ}$  Fahrenheit).

### **Transforming a Railroad Water-Tank into a Home for Two**

**A**N OLD water-tank in a Western town stood idle until an enterprising citizen came along and recognized in it the making of a home for himself and his wife.

He set to work with carpenter's tools, and in a week he had the interior fitted up comfortably. He cut windows where he wanted them and made a door large enough for the champion tall man in the

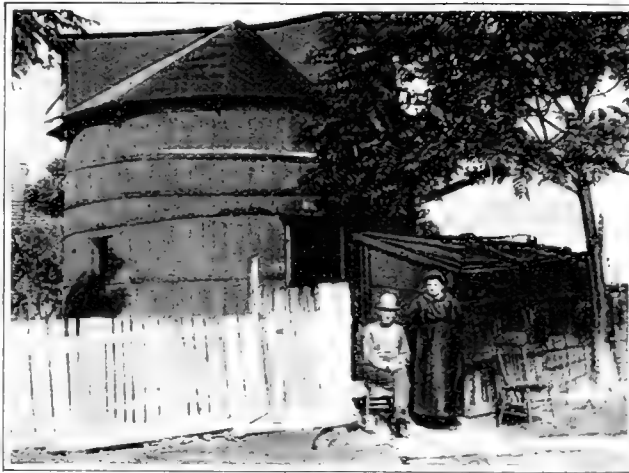

Love in an abandoned railway water-tank. There is even an upstairs and a guestroom in this improvised home

United States to walk through without ducking his head.

To disguise the tank-home as far as possible and also to add an element of architectural beauty to the whole, he fitted the roof with extensions, placing windows in the extremities.

This gave him the happy thought of building an upper room to the structure. Now he has plenty of room for guests, since he has finished off and furnished the addition as a spare chamber. A chimney was also added and stoves were installed.

## A Combination Lamp and Horn for the Motorcycle

ONE of the newest attachments for motorcycles is a combination horn and lamp to be fastened to the handlebars, the shell of the lamp forming a base for the support of the casing of the horn. It is the invention of Perrin B. Whitney, of New York city.

The shell of the lamp is round, as shown at 10 in the detail, and contains a reflector 11, which is so constituted as to form a resonating chamber for the horn. One or more light bulbs, 12, are also contained in the shell, and connecting wires, 13, pass outward through a specially arranged socket 14. A portion of the shell is flattened

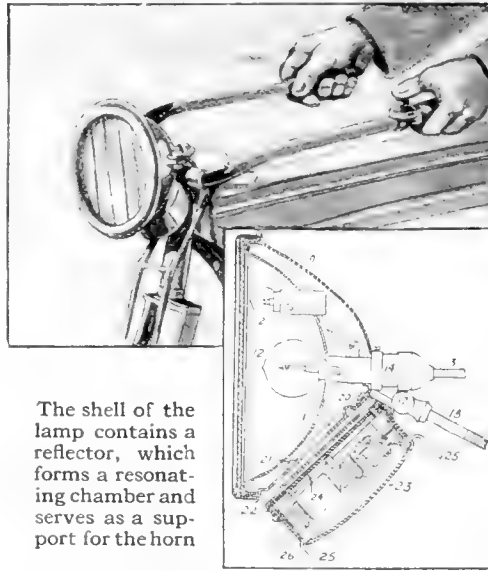

The shell of the lamp contains a reflector, which forms a resonating chamber and serves as a support for the horn

into disk-shape, 19, from which a number of short posts extend to the axis of the shell. To these posts the cylindrical casing which is the container for the horn is secured. This casing may be closed by a lid, or cover, 23, through which the wires, 25, leading to the electric vibrator 24, of the sounding device, extend.

The construction is very compact and simple. The sounding qualities of the horn are greatly intensified by the resonating chamber provided by the lamp shell. The device is adapted for use on automobiles and other vehicles as well as for the motorcycle, the shell being provided with means to attach it wherever desired.

## Money Prizes for Motorcyclists

### Send In Your Kinks

IF you are a motorcyclist, if you have devised simple ways of making repairs, if you have improved your machine in any way, this will interest you.

The POPULAR SCIENCE MONTHLY offers a first prize of \$25, a second prize of \$15 and a third prize of \$10 for articles in which motorcyclists will describe and illustrate the methods which they have successfully employed for overcoming trouble, for making quick repairs by the roadside or more difficult repairs in the shop, or for making attachments whereby the use of the motorcycle has been broadened.

The three prizes will be awarded by the editors of the POPULAR SCIENCE MONTHLY in the order of merit. What is more, even though your article may not win a prize, the editors may buy it at the usual rates, just because it is so good.

There are no limitations to this prize offer. We don't care for fine phrasing, but we do care for good mechanical

ideas. Rough pencil drawings or photographs will do for illustrations.

The following conditions are to be observed:

- (1) Articles must be written on one side of the sheet only.
- (2) Write your name and address in the upper right-hand corner of the first sheet.
- (3) Enclose postage for the return of the manuscript.
- (4) Don't send in articles on ideas which have already been published.
- (5) Don't send paper ideas—things that you haven't actually done yourself.
- (6) Address the envelopes containing articles to

"Motorcycle Contest Editor"

POPULAR SCIENCE MONTHLY

239 Fourth Ave.,

New York City

The contest will close on December 31st, 1916.

The money for the prizes will be paid promptly after the awards have been made.



# FOR PRACTICAL WORKERS

## Making Artistic Decorative Butterflies in Sheet-Copper

**T**O produce artistic effects representing butterflies in copper requires a little skill, a sheet of copper—about 20-gage—a jeweler's saw-frame and blades, artist's oil colors ground in light Japan, two camel's-hair brushes—one wide and the other pointed—and a fine drawing-pen known as No. 390. The colors of paints and inks used depends upon the design to be executed.

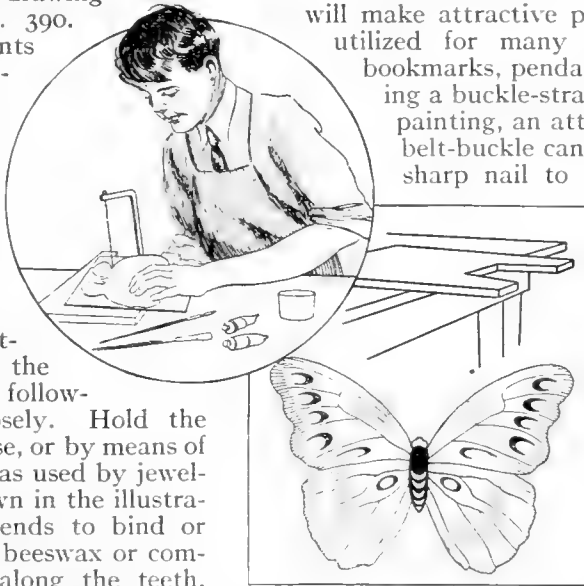

Select the butterfly, or a colored drawing of one, to be reproduced in metal and very carefully trace or draw the outline on a piece of the copper. Saw it out, following the outline closely. Hold the copper in a bench-vise, or by means of a bench-angle, such as used by jewelers, or like that shown in the illustration. If the saw tends to bind or chatter rub a bit of beeswax or common washing-soap along the teeth. Smooth the edges of the copper pattern with a fine flat file and go over the surface with very fine-grained emery paper.

The coloring is next in order. Suppose, for example, the butterfly to be reproduced is yellow with black-lined wings and body. Squeeze a little of the yellow oil-color on a piece of glass and mix it to a fairly thin consistency with the Japan drier. Dip up a good brush full and flow it evenly over the entire surface of each side with the widest brush, allowing one side to thoroughly dry before touching the other. Choose the smoothest side and with a well-pointed pencil trace very lightly the general mark-

ings on the wings and body; then with a pen and ink, copy the markings of the original as closely as possible. This ink will dry almost instantly and leave a dull surface. If a glossy surface is desired give it a coat of very thin white shellac. Spots of contrasting colors can be touched in with the smaller brushes.

An assortment of these varicolored flies will make attractive pieces which can be utilized for many purposes, such as bookmarks, pendants, etc. By soldering a buckle-strap to one side before painting, an attractive and original belt-buckle can be made. Solder a sharp nail to the under side and

drive in one end of a stick stained green and use for a plant stick. Several of these plant sticks supporting an assorted lot of brilliantly colored moths and butterflies, placed among the leaves of potted plants furnish a beautiful and realistic decoration for a window garden. —L. B. ROBBINS.

Coloring forms cut from sheet copper to resemble brilliant butterflies for decorative purposes

## Repairing Automobile Tires to Prevent Bulky Places

**B**ULKY-LOOKING repairs are often caused by the overlapping of the new plies of fabric on the old. When a piece of fabric is inserted it should lap just  $\frac{1}{8}$  in. all around. During vulcanization the air pressure and the expansion of the tire will draw the fabric down so that it will join the old fabric exactly without overlapping or any clumsy effect.

### A Clever Trick Performed with a Lighted Cigarette

A CIGARETTE is lighted and tucked into a closed fist from which it vanishes while still burning. The effect is mystifying, but the method is simple. Take a wood spool and whittle away both edges

The lighted cigarette is stuck into the spool which is drawn back into the vest-pocket by an elastic

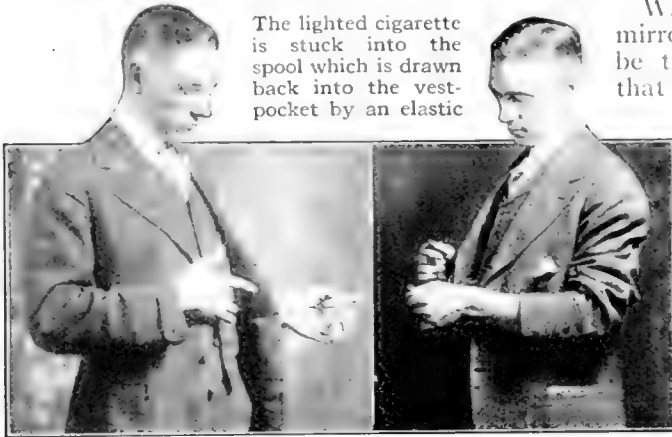

so that it represents a tube, one end having a tapering point. Drill a hole crosswise through the tapering end; pass one end of an elastic cord about 2 ft. long through the hole and tie it. Tie the opposite end to a suspender button. The vest conceals this elastic, which when taut is just long enough to allow the spool to rest inside the lower vest-pocket.

The trick is performed as follows: Borrow a cigarette and reach with the left hand into the designated vest-pocket for a match. In pulling out the match take the spool with it, concealing it in the fingers. Stand slightly sideways so that the coat will hide the elastic. Tuck the lighted end of the cigarette into the hole in the center of the spool—it is just large enough to hold the cigarette snugly without extinguishing it. Open the fingers and the spool containing the cigarette will fly back beneath the coat.—MERRITT HALE.

### Making Flexible Mirrors from Tinfoil on Celluloid

PROCURE a piece of celluloid—an old photographic film cleaned of the gelatin coating will suffice—and coat it as follows: Make a solution of  $\frac{1}{4}$  teaspoonful of plain white gelatin in  $\frac{1}{2}$  cupful of boiling water. Take a piece of tinfoil—not lead foil—and rub a few drops of mercury or quick silver on one side until it resembles a mirror. Wet the fingers in the prepared gelatin, size and rub it all over the surface of

the celluloid and lay the foil on, mercury-side down. Cover with a piece of newspaper. Hold it tight to prevent slipping, and burnish the foil down hard to the celluloid surface. This may be done with the end of a round paddle made of wood, or a similar hard surface.

When this has become dry a fine mirror will be the result. It may be twisted in almost any way so that it makes a very amusing device for distorting a person's reflection in all kinds of shapes, making tall people look ridiculously squat, and short, stout people look tall and lank.

Care should be exercised not to bend the celluloid too sharply as the foil will be wrinkled and the effect spoiled in consequence.

### Grinding Automobile Engine-Valve Seats Set in a Sleeve

A SIMPLE and speedy way to grind automobile engine-valves set in a sleeve is to fasten the stem in a vise, take a length of rawhide and wrap it once or twice around the sleeve as shown in the illustration. Fasten the ends of the rawhide into a hacksaw frame and draw it

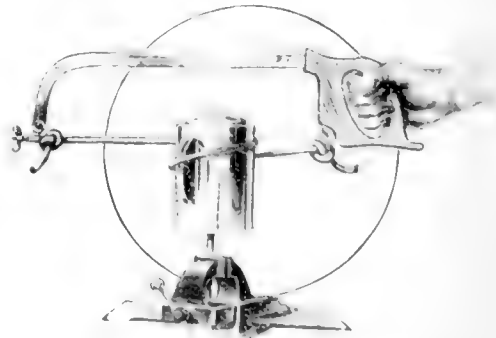

Turning the valve-sleeve about the valve stem in grinding the engine-valve seat

back and forth the same as in sawing metal. A turning motion is imparted to the valve-sleeve, which will grind in a new seat quickly with the use of properly applied abrasives.

When fastening the stem in the vise be sure to use some soft metal on the jaws, such as copper or lead, to prevent injury to the surface.



### A Water-Barrel Elevator in a Well

**A**n engineer in southern California has figured out the simple but useful device of a water-barrel elevator, on which he rides to and from his work in a well 210 ft. from the surface. Two men formerly on the job lost their lives riding down in a large bucket lowered by a windlass. The water-barrel elevator was constructed in the following manner. Heavy iron bands were put around the barrel, and a bail with a swivel to engage a wire cable that runs through a pulley above was fastened on.

The top of the barrel has an opening through which it is filled, and a faucet near the bottom allows for drainage. On the other end of the cable hangs a counterweight that, taken with the weight of the cable, almost balances the weight of the barrel and the engineer. A little water is taken on for ballast as he starts slowly downward. In descending, it is necessary to have the faucet turned on enough to allow for the increasing weight of the cable as it passes over the pulley to the side on which the descent is being made.

After reaching the landing, the engineer fastens the barrel to a hook. When he wishes to return he lets the water out and rises to the top.

This well is 300 ft. deep. The shaft measuring 6 by 8 ft., extends down 210 ft. to a landing, where an engine and motor are placed. The engine was originally used for power to run a centrifugal pump, but since a high-power line has been installed it has been found cheaper to place a 100-H.P. motor, making 950 revolutions per minute, directly on the shaft of the pump, which hangs suspended 50 ft. beneath the

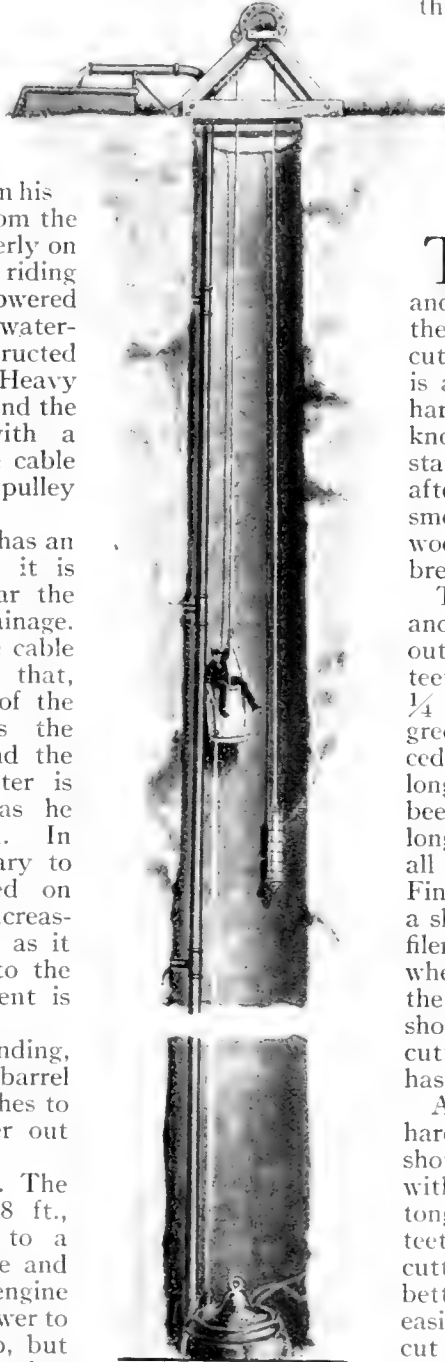

On one end of the cable hangs a counterweight which almost balances the weight of the water-barrel carrying the engineer. An engine and motor are installed at the bottom of the shaft

surface of the water. It has three steps or vanes, and raises 110 in. of water through a 6-in. discharge-pipe into a tank on the surface.

### Secret of Success in Filing Cross-Cut Saws

**T**O keep the cutting-teeth even and the points keen and smooth as a razor-edge is the main point in filing cross-cut saws. A rough-edged point is almost sure to break off in hard-grained wood, gnarls or knots. If saw-teeth points will stand the first two hours' work after filing, then they are worn smooth by the action on the wood and will not be likely to break at all.

The rakers must be swaged and adjusted so as to plough out all wood cut by cutting-teeth in strips or shavings from  $\frac{1}{4}$  to 4 in. long although in green hardwoods, spruce and cedar the shavings will be much longer. Spruce shavings have been found to be 11 to 14 in. long. The idea is to eliminate all fine sawdust, if possible. Fine sawdust is a sure sign of a slow-cutting saw and a poor filer. Often the saw is blamed when the filer and sometimes the operator is at fault. A filer should be able to put a fine cutting point on any saw that has good material in it.

A saw that is so glossy and hard that it will not swage should have the temper drawn with a pair of thick, red-hot tongs. If possible all raker-teeth should be softer than the cutting-teeth. They will give better satisfaction and will be easier on the filer; for a filer will cut nicely on the bevel-stroke used on a cutting-tooth long after it has ceased to be of use on the hard horizontal stroke required in sharpening a raker, which must have a perfectly square chisel cutting-bit so as to plough out the sawdust.

### A Toy Bank of Wood Fastened Together Without Nails

THE illustrations show a toy bank which is fitted and fastened together

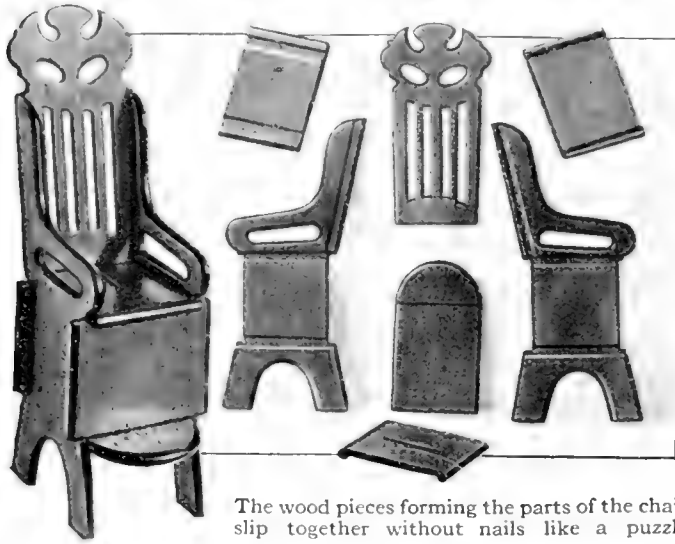

The wood pieces forming the parts of the chair slip together without nails like a puzzle

by checking and notching the several parts. The back of the chair is cut from a piece of wood 5 in. long by  $2\frac{3}{4}$  in. wide and  $\frac{1}{8}$  in. thick. The sides are  $7\frac{1}{4}$  in. long, cut from a  $3\frac{7}{8}$ -in. board,  $\frac{1}{4}$  in. thick. Each of these pieces is grooved for the back and cross-grooved for the top and bottom part of the box. The outline of these pieces is shown in the illustration. The width of the part that receives the front and back is  $2\frac{1}{4}$  in. wide. The front and the bottom parts are shown at the right and left in the illustration, and are 3 in. long by  $2\frac{1}{2}$  in. wide. Each is cut from  $\frac{1}{4}$ -in. board, which is left full thickness at the ends; but in the center across the whole breadth it is reduced to  $\frac{1}{8}$  in. thick for a length of  $2\frac{1}{2}$  in. The seat of the chair is cut and checked the same way and to the same size and has the addition of the coin slot. The bottom which is shown in the center, is  $3\frac{3}{4}$  in. long by  $2\frac{1}{4}$  in. thick. This is cut with a wide end to form the step for the chair.

Put the parts together by placing the sides in position with the back piece keeping them apart. Slip the seat in place, then the front piece, and lastly the bottom piece, which is the key to the complete money-box. Add the upper back, which slides in between the grooves cut in the sides of the chair. The coins are inserted through the seat and are taken out from the bottom. JOHN Y. DUNLOP.

### Making a Wood-Burning Heater for the Home

THE drawing below shows a system of house heating where wood is the only available fuel. The temperature in the locality where this is in use frequently reaches 40 deg. below zero. The house is never cold in any room on either of the two floors, and the thermometer stands at 60 to 70 deg. in the morning after the coldest nights.

An ordinary box stove for 4 ft. cord wood is built into a rectangular jacket with walls 8 in. thick. An air-space of 8 in. separates the concrete from the stove at the nearest points. The top of the wall is recessed so as to leave a 4-in. shelf to support the galvanized sheet-steel roof. This steel top has sleeves for the smoke-pipe and heat flues, and is supported by two iron bars, equally spaced between the ends. The front of the stove is built in flush with the concrete, allowing access to fire and ash-doors. The expansion of the stove is provided for where it passes through the

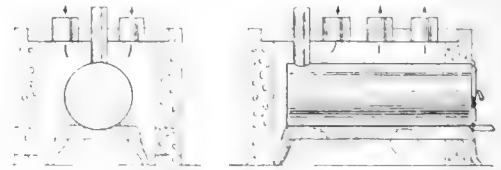

A concrete covering for an ordinary box stove



concrete, by a  $\frac{1}{2}$ -in. jacket of asbestos which prevents actual contact between the stove and the concrete. About 3 in. of sand or loam is placed on top of the sheet metal. The heat flues at the top are connected with those running to the registers in the different rooms.—J. A. NORTON.

**Making the Vibrations of the Voice  
Draw Designs**

ONE of the most interesting of modern scientific devices is the eidophone. By means of this instrument it is possible to secure impressions of sound vibrations in a curious and often beautiful form. It is really easy to make a box which will enable one to draw patterns with the voice. A glance at the accompanying illustrations will show that the things necessary to produce this contrivance are few and simple.

A tin saucepan of moderate size with a hollow handle, and a metal funnel will be required. These may be found about the kitchen of almost any home. The only necessary thing to purchase is a piece of sheet-rubber large enough to stretch over the top of the saucepan. Any kind of thin rubber sheeting will do, but the best for the purpose is that commonly employed for the making of toy balloons.

With these materials gathered together start to make the device by opening up the handle of the saucepan. Any sharp metal tool may be used to penetrate the tin and the opening should be the same size as the inside diameter of the handle, so that it resembles a tube. Push the funnel-end well down into the inside of the handle. The rubber sheeting is spread over the opening of the saucepan and tied down firmly at the sides with a string. It is important to draw the sheeting until it is as taut as the head of a drum. The eidophone is then ready for use.

To make the experiments, some kind of a very light powder must be used. Very fine sand, precipitated chalk, or lycopodium powder, procurable at most drug stores,

are all good. Whatever material is used should be spread in a thin layer on the rubber surface; then start to sing into the funnel a monotone note, steadily and continuously. In a short time it will be seen

that the particles of the powder are busily arranging themselves into a design, which varies quite perceptibly according to the note sounded and the material used for the powder. An endless number of fascinating experiments can be carried on in this way. Colored glycerin can be used also, which when

spread on the rubber will produce wavy patterns as the note is sounded in the tube. The only point to bear in mind is that in changing the substance on the rubber all traces of one material must be removed before another is put on.—S. L. BASTIN.

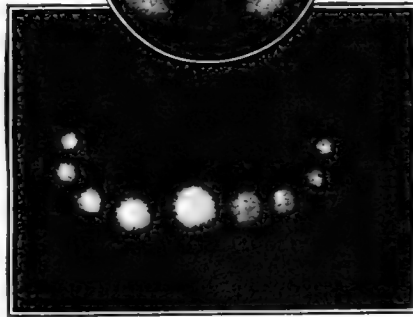

The vibrations set up by the voice produce beautiful designs in powder, chalk or glycerin on the rubber surface

**Friction Tape Used for  
Plaster Strips**

A "shop doctor" is called upon many times to bandage an injury while waiting the call of a regular physi-

cian. Adhesive tape is not always at hand, but usually some "friction" or "electricians' tape" may be had and can be used instead. This tape was tried out to keep a dressing on an ulcer on the heel of a sailor's foot during a long cruise. Almost the entire foot was well wrapped so that the man was enabled to walk the deck in his bare feet even when washing down. The tape being adhesive on one side provided a covering that was almost water-tight.

This tape has also been used in emergencies to make covers for dressing over hands and wristlets for sprained wrists. It is not preferred to zinc oxide adhesive tape but is valuable where the other is not at hand.—DR. OTTO SOMMER.

### A Home-Made Heating Arrangement

**N**CESSITY required that a house built solely for use in summer weather should also be used as a winter home, and the problem of keeping from freezing during the cold months was solved finally by the home-made heating plant illustrated herewith. There was a cooking stove in the kitchen, which could be depended upon to keep the kitchen and a part of the living-room warm. This left the up-stairs totally without heat. There was no hole in the chimney for a furnace pipe, but there were perforations in it on the living and chamber floors.

This suggested the following home-made furnace installation.

An ordinary cylinder stove was purchased and installed in the cellar, and a long stove-pipe run from this through holes in the two ceilings to the outlet in the chimney on the second floor. A 9-in. tin pipe was then jacketed outside of the stovepipe, and fastened in the two floors. Tin caps were bought with the larger pipe to fit on either end. Holes 1 in. in diameter were cut through these caps all around the circle. The object of these

holes was to admit fresh air in the lower end of the pipe and to permit the hot air to escape above.

When the fire was started in the stove in the cellar, the smoke and hot gas traversed the full length of the inner stovepipe, and in so doing heated all the air between it and the outside pipe. While the smoke and gas escaped through the chimney in the ordinary way, most of the heat which generally goes up the chimney was caught and radiated in the form of hot air in the upper chamber. Fresh air came up through the holes in the outer pipe in the cellar, and after traveling the full length of the distance from the cellar to the second floor it spread out as hot air to warm the bedrooms. The question of risk from fire was eliminated by using sheet asbestos wherever the pipes came near or in contact with woodwork.

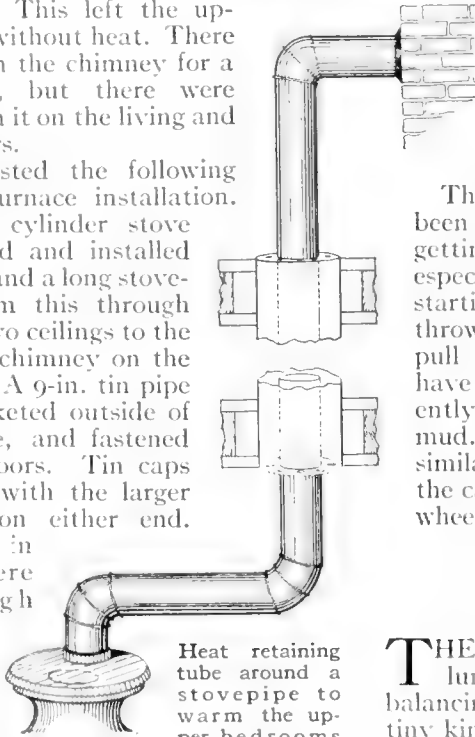

### Starting an Automobile When One Rear Wheel Is On Ice

**T**HE owner of an automobile happened to stop his car where the front wheels were in some mud, one rear wheel on a bit of ice and the other on solid ground. The mud was not deep, but there was just enough to prevent the car starting from a standstill with one driver on a slick surface. Having no tire-chains on hand he tried putting some sacks under the wheels in which the chains were kept. These were thrown out behind the car as fast as they could be put under the wheel. He finally pulled out by having some one push while the clutch was thrown in action.

The trouble as mentioned could have been easily overcome without the driver getting out of the car or doing anything especially different from the usual if in starting the car on low gear he had thrown in the brake enough to cause a pull on both rear wheels. This would have produced a tractive effect sufficiently strong to get the car through the mud. This idea can be used in many similar cases where it is difficult to start the car for lack of tractive power on one wheel.

### How to Make a Pendulum Swing Easily

**T**HE uneven swinging of clock pendulums is generally due, not to incorrect balancing of the pendulum weight, but to a tiny kink in the feather-spring from which the pendulum is suspended. If the face of the clock is taken off, the feather-spring may be twisted slightly in the right direction with a pair of tweezers or small pincers. This will correct the unsightly wobble and help to maintain the perfect balance.—RALPH W. THILLOTSON.

### Lifted Tread Sections in Making Automobile Tire Repairs

**M**UCH has been said about the lifted tread method of making a sectional tire repair, but many vulcanizers are still following the wasteful practice of cutting off the old rubber and throwing it away. Cut across the tread well to one side of the injury and peel it back. After the section has been built in, cement the tread and lay it back in place.

# A Motorcycle Bob

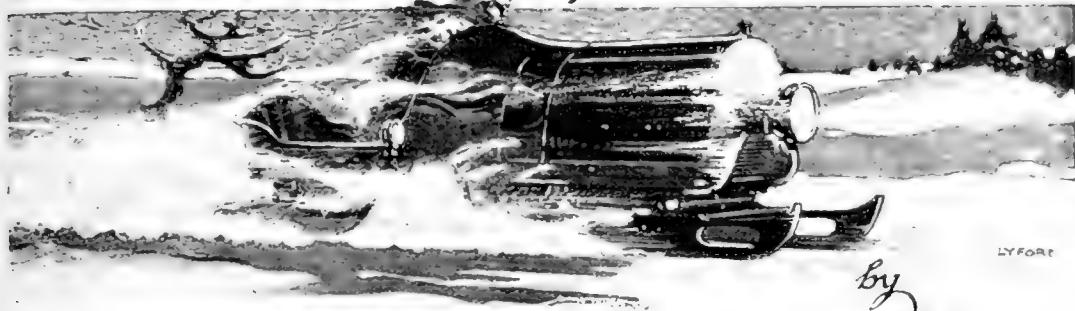

By  
Frederic B. Hart

## Convert Your Motorcycle into an Inexpensive Power Bobsled

**I**N designing this motor-bob it is assumed that the building will be done by motorcycle owners having limited facilities, therefore everything is made in the simplest form, of materials easily obtained. Except the woodwork, nothing is required beyond some pieces of 1-in. gas-pipe, a small piece of boiler-plate for the kingbolt support, some  $\frac{1}{8}$ -in. outside diameter brass tubing and steel wire for the ignition and throttle controls, and some  $\frac{3}{8}$ -in. rod and heavy strap-iron for the clutch-control and gear-shift. Many dimensions will have to be varied to conform with the motorcycle used for the power plant, so only general dimensions that are applicable to any machine are given, and even these may be changed to meet the requirements of the builder.

Only a general outline is suggested for a two-passenger seat and a hood for the motorcycle. If such a hood is used it should be open in front or covered with a wire screen. Vents for windows in the sides of the hood would be advisable.

### Frame Construction

The frame is constructed like the three-point suspension used on automobile engines, one point at each rear runner and the other at the kingbolt. The frame sides *A*, Figs. 1 and 2, are made of oak or other hardwood,  $4\frac{1}{2}$  in. wide,  $1\frac{1}{4}$  in. thick, and if the details of the drawings are adhered to, the length should be 9 ft. 9 in. The rear cross-member *B* is 30 in. long, 8 in. wide and 2 in. thick. There is a second rear brace *C* directly under *B* at the extreme end of the frame; this is 30 in. long, 4 in. wide and 2 in. thick. From this point the frame is somewhat narrowed, principally for appearance sake, and the front cross-members, *E* and *F*, are 24 in. at the forward edge and slightly tapered to conform with the lines of the frame sides. The cross-member *E* is 5 in. wide and 2 in. thick and the piece *F* is  $2\frac{1}{2}$  in. wide and 2 in. thick. At the center of the piece *E* is a block *G* 5 in. long and 2 in. thick, and with a width equal to that of the distance between the fork-ends on the motorcycle. Further de-

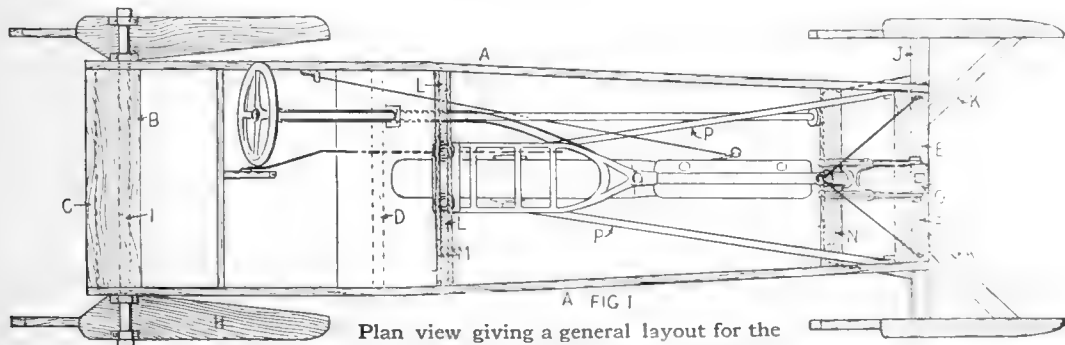

Plan view giving a general layout for the parts, frame and steering arrangement

tails of this block will be taken up in the order of construction for setting the motorcycle.

### Rear Runners

The rear runners are built independently of each other and should be made of 1½-in. hardwood 44 in. long and 9 in. wide. Make the top plate *H* of 1-in. hardwood 36 in. long and 6 in. wide. These top-plates should be secured to the runners in such position that the outside edge extends about 2 in. beyond the outer face of the runner. Care must be taken that this plate is directly at right angles to the runner. Put a triangular brace directly under the supporting tube as shown in the dotted lines in Fig. 3. As these runners must have a free movement to pass over obstructions they are not attached directly to the frame but to the axle-tube *I*, Fig. 1. The axle is

In the center, for a distance of about 7 in. use the full width of the piece, then cut on an angle to 3 in. in width as shown in Fig. 4. At a distance 20 in. from the front end of each of the runners cut a notch 2½ in. wide and 2 in. deep to receive the ends of the crossbar *J*, Fig. 1. The top-plate of the front runners is 2 in. wide and 1 in. thick. As a part of the crossbar ends projects 1 in. above the top of the runner this must be removed so that the plate will set on the runner-top and come level with the crossbar surface. To further stiffen the runners laterally, triangular braces similar to those in the rear runners are set as shown in Fig. 4. Diagonal braces *K*, Fig. 1, must be added to stiffen the runners for steering.

The frame and the front runners are pivotally connected by means of a king-bolt which should be about 12 in. long and

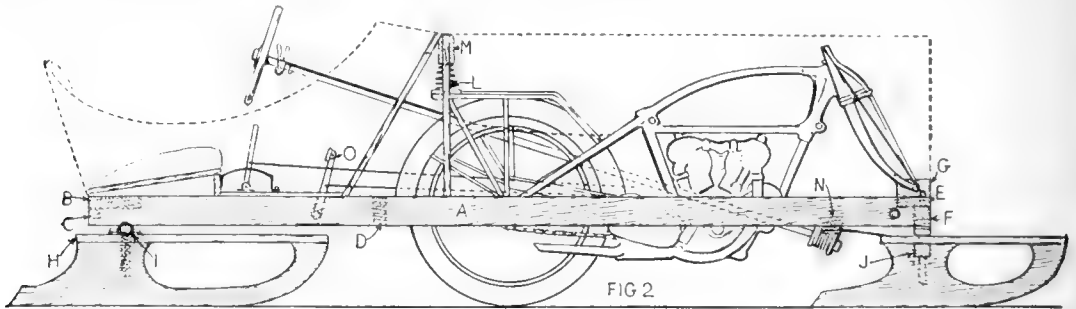

Elevation of the motor-bob, showing the location and parts of the motorcycle used, steering arrangement and main frame with dotted line designating the outline for a body and motor-cover

a piece of 1-in. gas-pipe, or, if preferred, a piece of 8-gage steel tubing 1¼ in., outside diameter. Make six stirrups out of 1-in. by ½-in. strap-iron. Two of these are used for securing the tube to the frame sides, the other four for securing the runners as indicated in Fig. 3.

The stirrup-clips for securing the runners to the axle-tube must be loose enough to allow the runners to turn on the tube. Thread the ends of the pipe and screw ordinary pipe-caps thereon to hold the runners in place. The outline of the runners should be long and flat, about as indicated. These may be either solid or cut out as suggested in the illustration.

### The Front Runners

Build up the front runners as one unit with each runner 36 in. long, 9 in. wide and 1½ in. thick. Make the flat part of these runners about 24 in. long to facilitate turning the front part in steering. The center crossbar *J* should be of hardwood 42 in. long, 4 in. wide and 2½ in. thick.

It is located 1½ in. from the front of the frame and directly in the center, where a vertical hole is bored through the pieces *G*, *E* and *F*. In the center of the crossbar *J* of the front runners drill a hole large enough to receive the kingbolt and taper it outwardly toward the bottom so that there may be some play for the bolt.

Cut from a piece of boiler plate, or any ¼-in. steel, a plate 6 in. long and 2½ in. wide. In the center of this make a hole to receive the kingbolt. Near each corner of the plate, drill and countersink holes for ¼-in. wood screws. These are used to secure the plate to the crossbar *J*. Between the plate and the frame member *F* place a large washer to further facilitate the turning. Put on a similar washer at the lower end of the kingbolt and finish with either a large nut or cotter.

### Mounting the Motorcycle

Having proceeded thus far the chassis is ready for the motorcycle. Remove the

front wheel of the machine and all the movable parts of the spring-fork, leaving only the main fork as shown in Fig. 2. Bore a cross hole through the block *G* just back of the kingbolt and secure the fork to the block by means of the front axle. To maintain the motorcycle in a vertical position make the support as follows:

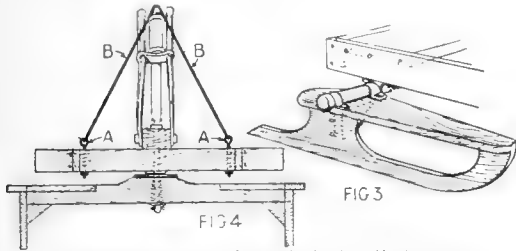

Rear runner and front-bob detail showing the plan of teetering and tilting devices

Make two eyebolts, *A*, Fig. 4. These bolts should be at least 6 in. long as they are used for adjusting the stay-rods *B*. These stay-rods are made with an eye at the lower end for linking into the eyebolts *A*. Bend the upper ends into a hook to engage the fork stem. Place these in position as shown and tighten the nuts at the lower end of the bolts *A*, so that the motorcycle may be readily adjusted and secured in a perfectly vertical position. Do not use continuous rods for this purpose, as there must be a hinge-action at the eyebolt to allow for the vertical movement of the rear wheel of the motorcycle.

The rear of the motorcycle is supported by the brace *L*, Figs. 1 and 2, which is shown in detail in Fig. 5. Make two guides *A*, and secure them to the frame sides by means of screws or bolts to allow an opening between the guides just wide enough to bear against the luggage-carrier. The crossbars, *M*, Figs. 1 and 2, should be located at least 4 to 6 in. above the top of the luggage-carrier. Cut a crossbar *B*, Fig. 5, from a piece of hardwood  $\frac{3}{4}$  in. thick and notch it at the ends as shown in the detail *C*, making them wide enough to let this bar move freely on the guides *A*. Between *B*, Fig. 5 and the crossbars *M*, Fig. 1, insert two spiral springs each strong enough to exert an initial pressure of at least 25 lbs. and preferably 50 lbs. when in position. The purpose of these is to prevent the motorcycle from jumping up and down when running over obstructions.

To transmit the driving force from the motorcycle wheel to the bob take two pieces of  $\frac{1}{2}$ -in. gas-pipe, or 1-in. No. 16-

gage steel tubing, flatten them at the ends and drill one end to fit over the rear axle ends. Let these tubes extend forward as shown at *P*, Fig. 1, bolting the forward ends to the frame sides close to the front ends. It will be readily seen that without these braces the drive would be transmitted to the sled through the front forks which should not be subjected to such strain.

Steering Apparatus

Steering is accomplished by means of a wheel. The steering post may be constructed of 1-in. gas-pipe and the wheel may be simple or elaborate, according to individual taste. At the lower end of the pipe secure a spool of hardwood about 3 in. in diameter with about 1 in. of the pipe projecting beyond the spool. On the crossbar *N*, Figs. 1 and 2, place a piece of flat iron about  $\frac{1}{4}$  in. thick as indicated, thus furnishing the support for the lower end of the steering post. Run a pin through the end of the pipe or screw on an ordinary pipe-cap to prevent the post from backing out of the collar-plate. Support the upper end of the steering post by passing the post through the upright guideway at the rear of the motorcycle. The detail is shown in Fig. 6.

A piece of  $\frac{1}{4}$ -in. cable wire is anchored solidly to the spool and two turns of it are run around the spool each way from the anchor and wrapped so that the wire will leave the spool in each direction from the bottom. Pass these wires around grooved pulleys pivoted on the ends of the crossbar *N*, Fig. 1, and thence to the crossbar of the

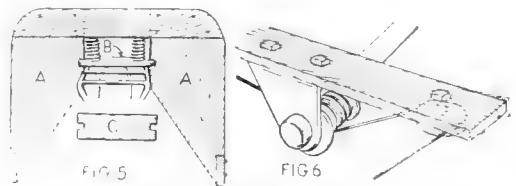

Guide for the rear part of the motorcycle and steering-cable supporting connections

front runners. It is readily seen that by turning the steering wheel to the right the right end of the runner will be pulled backward and the motor-bob will steer to the right, and vice versa.

The Controls

The question of control is a matter to be determined by the kind of motorcycle used, and only general suggestions will be offered. The spark and throttle can be



best operated by means of a spring-steel wire working inside of a  $\frac{1}{8}$ -in. outside diameter brass tubing. A suggestion for the construction of this is shown in Fig. 7. If the levers and tubes were secured directly to the steering post they would necessarily turn with it, but if a piece of steel tubing that loosely fits over the steering post is slipped in place and the lower end secured

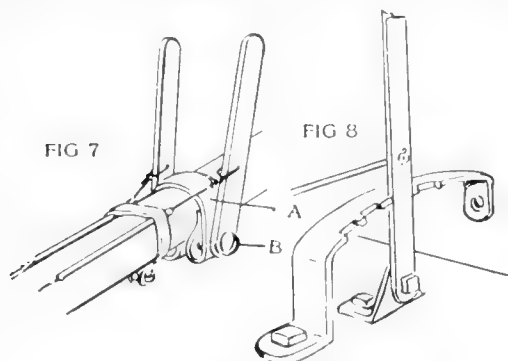

Motor-controlling lever attachment to steering post and clutch-lever quadrant

either to the sloping footboard or to the wheel guide *L*, Figs. 1 and 2, the steering post can be turned inside the tube without interfering with the controls.

The clip *A*, Fig. 7, is looped as indicated so that when the cross-bolt *B* is drawn up, the loops of the clip will bind on the under side of the tube, thereby holding the clip in place without drawing the bolt *B* so tight as to interfere with the movement of the levers. Secure the upper end of the two pieces of  $\frac{1}{8}$ -in. brass tubing to the steering post about 2 in. below the levers by means of a single metal strap or clip. Run these tubes down the steering post and then to the throttle and spark controls, securing the ends to some nearby part of the machine; then run the wires through the tubes, securing them to the steering-post levers and the throttle and spark levers in any convenient manner.

For the length of time the motor-bob will be used, a reasonably satisfactory connection can be made by simply looping the ends of the wire through the holes in the levers and wrapping the ends around the main wire as shown. For the gear-shift, make a lever and segment as shown in Fig. 8, notching the segment in proper position for the gear-setting. Disconnect the gear-shift mechanism of the motorcycle and run a  $\frac{1}{4}$ -in. rod from the lever to it.

For clutch operation, make a lever as

shown at *O*, Fig. 2. Bolt this to the frame side and let it come upward through the floor. Connection between this and the clutch-lever should be by means of a  $\frac{3}{8}$ -in. rod or steel tube. If the clutch can be made to operate by a pull instead of a thrust, then extend the lever below the pivot so that the operation may be by means of a wire fastened to the lower end of the lever.

No special instructions have been given as to means of joining the various frame parts and a wide leeway has been allowed for individual ideas and facilities.

### Filtering Gasoline Through Chamois a Dangerous Performance

FROM a well known authority comes the statement that to strain gasoline through chamois is dangerous for the following reasons: When gasoline is poured on a chamois, static electricity is created and it is apt to fire the liquid. As long as the funnel fits the tank opening a ground is formed and there is no spark, but, if for any reason the funnel is held up or is not in contact with the tank, a spark is likely to jump across from the funnel to the metal of the tank with disastrous results.



The funnel is held up by the seat board but a spark may jump the gap into the tank

Many tanks are set into the seats of the automobiles, as shown in the illustration, consequently the passing of the gasoline through the chamois in the funnel sets up the static, and if a sufficient amount is stored up, a jump spark issuing between the funnel and the tank will be likely to cause a fire with serious results.

**Photographic Printing Masks  
Easily Made**

**P**rinting masks are easily made from the black paper found in all negative boxes. After determining the size of opening desired, a rectangular mask is cut as follows:

Take a sheet that is large enough to fully cover the negative and fold it two ways to make four thicknesses. Make the folded edges exactly even with each other—they will then be perfectly square. Lay off at right angles to the shorter fold, one-half of the longer dimension of the

It may be improved by moistening between two damp blotters in the press till the folds disappear. A number of modified corners may be devised for use with such rectangles by the aid of the red paper seals sold by stationers, or a little ingenuity will enable the operator to cut these designs from the black paper with scissors.

Oval, elliptical, or circular masks, can be cut with shears, after laying out one-fourth of the figure as shown in the illustration. Finally, any special shape, symmetrical about one axis, can be laid out with pencil on a doubled sheet (the fold forming

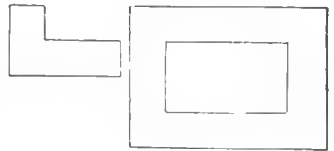
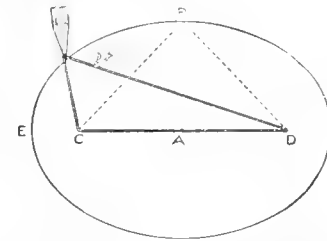
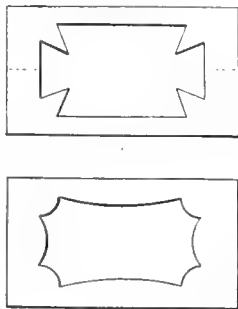
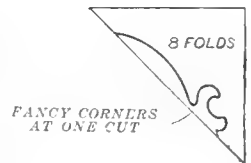
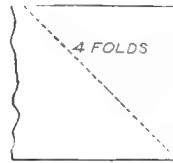
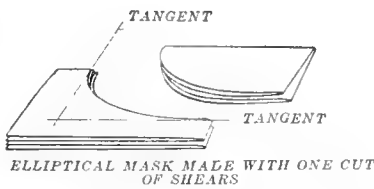
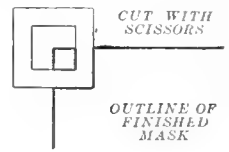
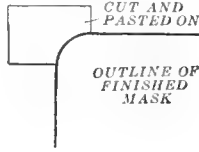

All patterns for making cut-outs and fancy corners for photographic masks are easily formed with a four-fold paper, cutting all the quarters at the same time with a pair of sharp scissors

opening desired, and mark, preferably by nicking the folds with the point of a sharp knife. Do the same with one-half of the short dimension on the other folds. Lay a straight edge (an old negative will do), on the nick. Repeat the measurement to the straight-edge at the outer edge of the folded sheet. Nick this with the knife. Draw a fine pencil line between the two nicks. Repeat with the remaining measurement. Cut along the straight edge from the pencil line to the nick. Cut at right angles along the pencil line from the first cut to the nick. When opened up, a true rectangle of the required size is obtained.

the axis) and cut with shears. The results, after a little practice will be absolutely satisfactory, and will be endless in variety.

For larger sizes, the various geometrical figures can be laid out with accuracy by the use of drafting instruments. Directions for describing all ordinary geometrical figures can be found in almost every engineer's hand-book.

To describe an ellipse, however, with little trouble, requires only a rule, two pins, a piece of string and a pencil. Having determined the length and width, draw two axes at right angles. The intersection is marked *A* in the diagram. From *B* lay off

$BC$  and  $BD$  equal to  $EA$ . Stick in a pin at  $E$  and  $D$ . Tie a string around the two pins in a loop which, when pulled tight by inserting a pencil point as shown, will lie on the triangle  $BCD$ . If the pencil point is now moved carefully around the two pins, keeping the string stretched taut, it will describe the required ellipse.

Thin mats, masks for passe-partout, etc., can also be cut by this method. Always press between damp blotters, and afterward between dry ones to remove the creases. It cannot be used, however, on material thick enough to crush or break when folded, without marring the work. In this case the work should be laid out on the back of the mat with a pencil and cut carefully to outline with a sharp knife. A penknife is not a suitable tool for thick mats. The best tool for the work is a common one-piece steel table knife, broken within  $1\frac{1}{2}$  in. of the handle and ground to a dagger point.

#### A Buffer to Stop Sprinters in Indoor Sports

TO take the place of large gymnasium mats, or a wood track with an elevation at the end to retard the speed of sprinters in indoor sports the arrangement shown in the illustration has been devised. It consists of a framework to set against the wall with a base and top extension for attaching a canvas buffer. The framework should be of a size to hold a canvas 6 ft. long by 3 ft. wide, with suitable ropes hemmed in at the sides of the canvas and their ends extending for fastenings. The lower ends of the ropes are provided with hooks which catch into rings on the base or into plates fastened to the floor. The upper ends have a coil-spring and a hook on each one to make attachment to the top of the frame or ceiling.

Athletes running strike the canvas with a turn so that it throws them back lightly on the track. The frame is not necessary

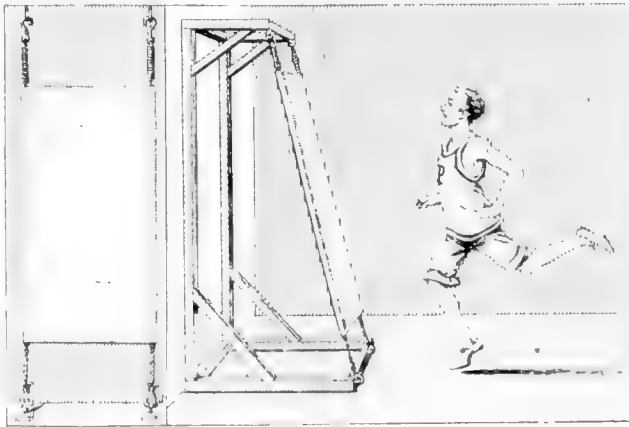

A frame built up to hold a canvas for stopping indoor runners

where there is a low ceiling, as the hooks may be attached directly to the floor and ceiling.—A. B. WEGENER.

#### Removing Collar on Change-Gear Spindle of Lathe

TO change over gears for compound trailing on a lathe to cut threads it is necessary to remove the belt-cone and

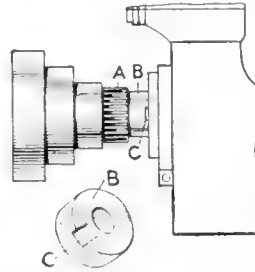

Groove for easily removing collar when using compound gears

reverse the gear  $A$  and collar  $B$ . The collar is difficult to remove because of its smoothness and its close fit to the boss face on the lathe head. This may be easily accomplished if a small groove is filed in the collar at  $C$  sufficiently deep to take the end of an ordinary screwdriver.—C. ANDERSON.

reverse the gear  $A$  and collar  $B$ . The collar is difficult to remove because of its smoothness and its close fit to the boss face on the lathe head. This may be easily accomplished if a small groove is filed in the collar at  $C$  sufficiently deep to take the end of an ordinary screwdriver.—C. ANDERSON.

#### Making Extended Index Tabs for Books

TAKE a piece of heavy, gummed paper tape 2 in. wide by about 14 in. long and fold it in the center lengthwise. Cut a piece of cardboard  $\frac{1}{4}$  in. wide and 14 in. long. Dampen one side with a sponge and lay it on the tape against the crease. Dampen the remaining side and fold over the other wing of the tape. When dry, cut into  $\frac{1}{4}$  in. widths, moisten the gummed

wings and insert the sheet to be indexed, pressing it down tight. The extended portion may be lettered alphabetically or otherwise, according to individual taste and the use to which it will be put.

While this may not look so well as a leather index from an artistic viewpoint, it will, nevertheless, prove very serviceable and the cost of the materials from which it is made is almost nothing.

**Changing a Boy's Handcar into a Mechanically Propelled Sled**

THE ordinary handcar sold at almost any toy store, or the car operated by foot pedals, is not of much use when 1 ft. of snow covers the ground, and it is usually

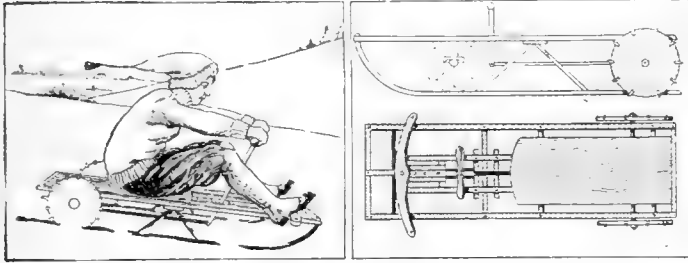

If the front wheels are removed from the handcar it can be securely fitted over an ordinary steerable sled with room enough to accommodate the driving wheels

stored away until milder weather returns. The sled takes its place in outdoor sports, but coasting down hill and sliding across the ponds does not, after all, take the place of a motive power that can be kept up indefinitely on the level, whether on the ice or snow.

The ordinary hand or foot-pedal car can be mounted on runners and different wheels substituted, and an ordinary steerable sled can be fitted to it with little trouble. First remove all four wheels from the handcar, then fit the sled over it and fasten it down firmly with a few bolts. The handcar stripped of its wheels is so much smaller than the average steerable sled that little trouble will be found in fitting them together. It may be necessary to use a few blocks of wood here and there to bring the parts into a snug, firm fit.

The main thing is that sufficient room should be made on either side to accommodate the rear driving-wheels. These are fitted to the axles of the handcar, and may be made from solid pieces of wood 1 in. thick. The rim of the wheels when placed on the axles should clear the ice by about 1/8 in. when the sled is standing on its runners. By measuring this distance the wheels can be made the right diameter. Find the exact distance from the hub to the ice, and then with a string form a circle on a board from which the wheel is to be cut.

Cut out the circle with a compass saw, then make ten 1-in. notches around the rim at regular intervals. Hard wood only should be used for the wheels or they will not stand the strain. Into the notches

made in the rim small galvanized pieces of iron are inserted with their sharp points projecting outward and forward. These points are the buckets which give tractive power to the sled when on the ice. If this method is too elaborate ordinary 1-in. screws may be used, inserted half their length into the wheel, and then filed so a point will be formed. Even ordinary heavy nails can be used, driving them in firmly, and filing off the heads to a point.

The sled is intended to rest on the runners, but the brads of the driving-wheel touch the ice or snow and give tractive power. When the hand or foot-pedals are worked, the tractive or driving-wheels revolve, and the brads digging into the snow or ice will give propelling power. If the back wheels are nicely adjusted, three times the speed may be obtained from the motor sled than from the handcar. The reason for this is that there is less friction to overcome. Ice or hard snow may be crossed with ease, and it will even climb small hills.

Everything depends upon the adjustment of the driving-wheels. If the brads project more than 1/8 in. below the runners they will impede the progress.

**Removing a Bushing from a Blind Hole**

OFTEN it is necessary to put a blind bushing in a fixture for gaging purposes, the bushing being pressed in as shown at A; then before the job is complete it may be required to remove the bushing, through some error. The usual method of

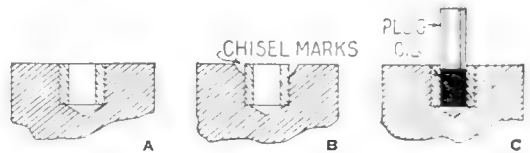

Two effective methods of removing close-fitting bushings in fixtures and jigs

removing the bushing is shown at B. A very effective way is shown at C, wherein oil is run in the hole and a close-fitting plug or plunger driven in with a hammer. The compress oil forces the bushing out and there is no danger of damage being done to the parts.—A. H. WADELL.

### A Dark-Room Lamp to Be Used Under a Glass Tray

THE lamp illustrated is a very handy instrument for developing plates and films. It consists of a light-tight wood box *A* containing a small lamp *B* and a reflector *C*. The size of the ruby

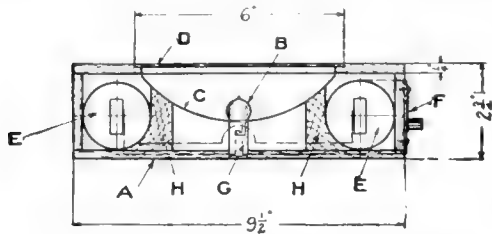

The developing tray of glass is placed on top of the ruby glass of the lamp

glass *D* depends upon the size of the plates used. There are two dry batteries *E*, about 6 in. long by 2 in. in diameter which supply the current for the lamp. The circuit is opened or closed by the switch *F*. Two wood blocks *H* keep the batteries *E* in their proper place and support the reflector *C*. The developing dish must be of glass and is placed on the ruby glass *D*. The dry plate or film is then put in the dish, the developer poured on and after about half a minute the lamp *B* is switched on for a few seconds. Without taking the plate out of the dish one can judge the development as the light is thrown through the ruby glass *D*, and through the bottom of the developing dish and the negative. This is repeated until development is complete.

Since the dark-room lamp described here is the only source of light in the dark-room, and is used only at intervals for a few seconds, there is no possibility of fog.

The dimensions given refer to a lamp for plates 4 by 5 in. The reflector *C* may be German silver and about 1/32 in. thick and fastened to the wood blocks *H*. The dry cells are connected in series. The ruby glass *D* fits in a recess in the top of the board of the box

*A* and should be glued to that board.

With reasonable care the batteries will last at least a year and the amateur photographer will find that the negatives are far better developed in this manner. Roll films can be developed in the same manner as plates by attaching them to a glass plate of the same size as the film, using rubber bands to hold it closely to the plate surface.—V. A. OLDROYD.

### A Sanitary Home-Made Tooth-Brush Holder

PROCURE a small bottle and fasten to its lower part a wire hook with an electric or rubber band. The hook is used for hanging the bottle to the wall in a convenient place. The tooth-brush is forced through the neck, which holds it until needed for use. The bottle is hung in an inverted position.—JAMES E. NOBLE.

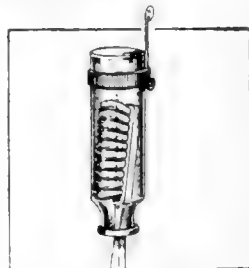

The toothbrush is forced through the neck of the bottle

### A Fountain Attachment for Ordinary Pens

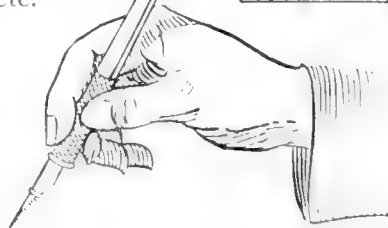
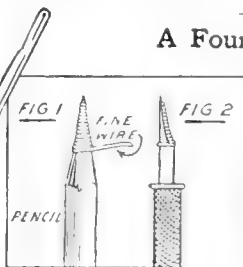

The coil of wire makes the fountain for an ordinary pen

AN ordinary pen can be made into a fountain pen quite easily by attaching a small fountain made of wire.

To make this fountain wrap a piece of fine iron wire around the point of a sharp pencil as shown in Fig. 1, leaving about 1/4 in. straight. To fasten it to the pen, wrap the straight wire around the pen-shank. The coil part is fitted into the underside or hollow part of the pen with the pointed end down, as in Fig. 2. The coiled part forms a pocket for holding the ink which is fed to the pen between the coils. The dipping of the pen in the ink fills the coil. This fountain will hold a good quantity of ink.

Substitutes for the Ordinary  
Carpenter's Levels

A Good Substitute for a Solid  
Round Belt

**I**N laying the foundations of a house a rubber hose may be used as a substitute for a carpenter's or engineer's level. The illustration explains how to use it. It is evident that the water will be at the same level in both ends of the hose.

Another way is to set a tub almost full of water at about the proper height, near the center of the building. A block of wood supporting a long rule, as shown in Fig. 1, is placed on the water. As the block can turn around freely, the leveling can be obtained in all directions. To adjust the rule, direct it to a point *A* at some distance, turn the block end for end, and if the rule points exactly towards *A* again, it is properly placed. By moving a small stone *B* back and forth on the block, the proper adjustment can be easily obtained.

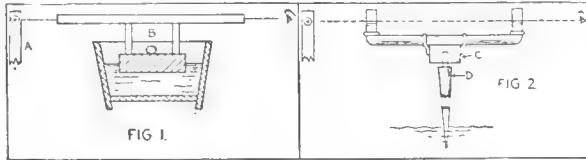

Two methods of constructing an accurate level, using water as a medium to obtain the straight-edge or sighting level for a distant mark

The best method is to make the water-level as shown in Fig. 2. This level can be made by anyone handy with tools. It is composed of a block *C* that can revolve on the end of the staff *D*. To the block is attached a tube 3 or 4 ft. long, terminating at both ends with glass tubes—lamp chimneys will do. Water is poured in until it reaches about half way up the tube. No adjustment is needed since the water is at the same level in both tubes. The instrument is far more accurate than one would suppose and is amply sufficient for use in laying

**W**HEN a round belt of the kind used on a jig-saw machine, or light lathe, is required and a solid round belt cannot be obtained, a very good substitute, superior in some ways to the solid belt, can be made by using a rawhide belt lace somewhat longer than needed. After soaking it in warm water for some time to soften the leather, proceed to twist

it up until it is perfectly round. Then hang it up to dry with a weight of 30 pounds or more on the end. This will make a belt with a better grip than that of the solid belt, and it has the added advantage of being adjustable. By undoing the ends and either twisting or untwisting it, the length can be increased or curtailed considerably. The twisted leather belt will also have a better grip on the grooves of pulleys than the smooth-surface round kind.

For fastening the ends, make a close spiral spring about 2½ ins. long and of such a diameter that the round belt will fit in tightly. When the two ends of the belt meet in the center of the coiled spring the ends of the wire are passed through the leather in the form of a hook. This makes an ideal joint which has flexibility and is easily removed for tightening. It will not tear out like the usual hooks on account of the holes being so far away from the ends. Also because the spring is pulled out, it contracts and grips the belt more firmly.—

B. E. DOBREE.



The water poured into a length of hose will reach the same level at both ends

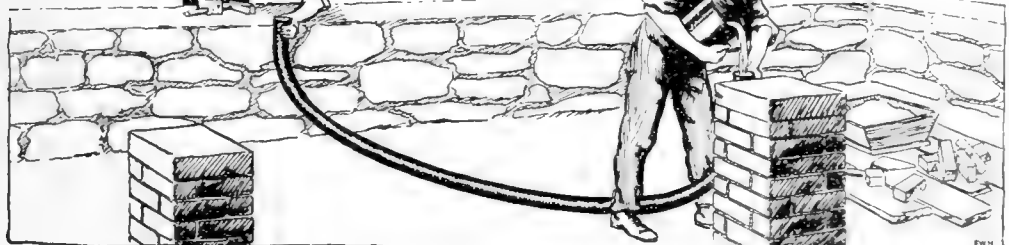

ADRIAN GETAZ.

### To Prevent Steel from Rusting After Soldering

**S**OLDERING acid will cause steel surfaces to rust rapidly after the job is finished if not thoroughly cleaned off. If there is much of this work to be done it is well to have a bottle on hand filled with a solution of ordinary washing soda. When through soldering apply the soda water and wipe dry. A block can be made to hold both the acid and the soda water bottles where they will be convenient for the work.

### Luggage-Carrier to Attach to Your Bicycle

**T**HE front fork of an old bicycle frame and a rectangular board will make a practical luggage-carrier for a bicycle.

Cut off the steering tube about 1 in. above the crown of the fork. Remove the outside nuts which secure the rear axle, slip the holes in the jaw-end of the fork over the axle-ends and replace the nuts.

Bore a hole in the board so as to permit the sawed-off steering post to enter it. Cut slots in the other end to permit the board to fit around the seat-post. A strap will hold the board-end securely to the seat-post. Make it of metal and

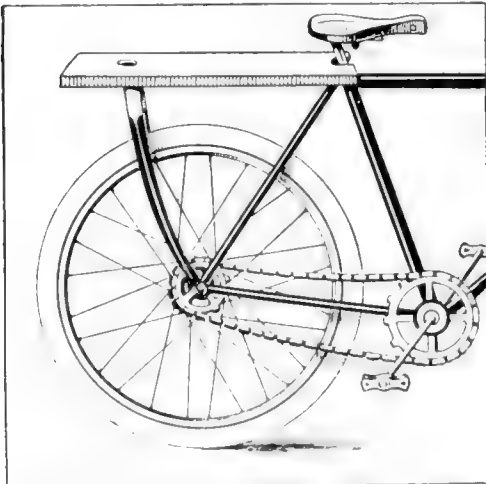

A board and the front fork of a bicycle make an excellent luggage-carrier

fasten with screws to the end of the board. Dimensions can be made to suit individual cases.—SEYMOUR CLARK.

### Automobile Carbureter for Heavy Fuel Oils

**T**HE automobile carbureter illustrated is designed for use with low grade or high grade gasoline, naphtha or kerosene, or a mixture of these. It

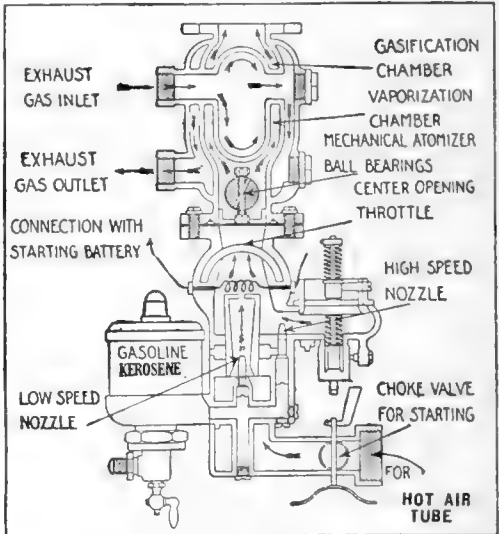

A carbureter specially designed so that low or high grade fuel oils may be used

differs from other types in that the passage of an electric current through a coil of wire connected with the storage battery of the car's ignition, lighting or self-starting system is placed below the throttle to heat the mixture enough to give instant ignition when starting. This is necessary because low grade fuels, such as kerosene, will not vaporize sufficiently when cold to form an explosive mixture. In most other carbureters using heavy fuels, the motors are started on gasoline and then switched over to the heavy fuel.

The coil only serves to start the motor, after which the current is turned off. After the motor is started the fuel is kept heated by passing the exhaust gases through a chamber surrounding the top of the carbureter between the throttle and the point of attachment, to the intake cylinder of the manifold.

**A**NAIL may be more easily drawn if it is first struck a blow with the hammer. This starts the rust.



**An Automobile Revolving Washer  
Made from an Old Rim**

THE accompanying illustration shows an automobile or carriage-wash-stand fixture the base of which is an old clincher-rim. This was made by a garageman in spare time and does the work as well as any fixture of this kind that can be obtained on the market. Much better results are secured and time saved if the hose is attached to an overhead revolving fixture, as it enables the operator to walk around the car without dragging the hose or "kinking" it.

Two pieces of 2-in. by 4-in. stringers are attached to the ceiling beams, these being spaced by a 12-in. by  $\frac{7}{8}$ -in. board which acts to steady the water-pipe passing through it and leading to the source of supply. A swinging union coupling, or elbow, is needed to join the rotating and non-rotating parts of the water-pipe, which may be constructed of

either  $\frac{3}{4}$ -in. or 1-in. standard-iron form. The rim is firmly secured to the stringers by clamps bent from  $\frac{3}{8}$ -in. cold rolled rod as indicated in the drawing. The pipe is supported by a simple trolley-wheel fixture clamped to the pipe, the wheel being grooved so it will be guided by the curved flange of the clincher-rim. This makes it possible to swing the pipe to which the hose is attached around so that all parts of the body or running gear may be easily reached, and it keeps the hose from rubbing on the floor.—V. W. PAGE.

**How to Make a New Bureau  
From an Old One**

THIS was the method used to change the entire appearance of an old bureau. The mirror was taken off the back posts and put out of harm's way. The brass-plated fixtures were removed and scraped. All useless ornaments were taken off. Then the varnish was removed with the aid of a common square scraper, some carborundum paper and some steel wool. A curb about 3 in. high was put at the rear edges of the top, to prevent small articles from falling down between the bureau and the wall.

Four coats of white lead and oil, with a dash of turpentine and Japan drier were given, 48 hours apart. After the fourth coat the job stood for three days to harden. The surface was then worked over with steel wool until all brush marks and roughness had disappeared. Then two coats of ivory white

enamel were applied, 48 hours apart. With this done the bureau looked like unglazed porcelain. China knobs were used for the drawer pulls. The drawers had previously been examined and the slides rubbed with white castile soap so that they worked smoothly.

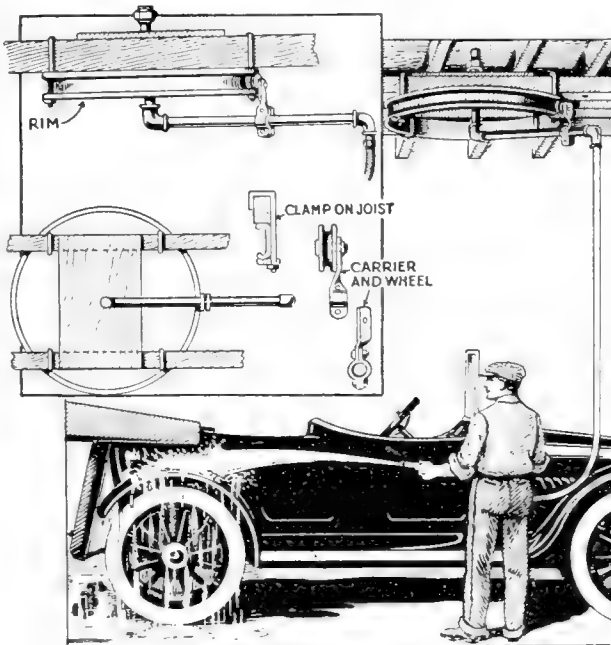

The rim furnishes an excellent track for a pulley to carry the pipe in a circular sweep on the ceiling

**A Quickly Made Silver-Plating Powder**

A good silver-plating powder can be made of chloride of silver, 3 oz.; salts of tartar, 6 oz.; prepared chalk, 2 oz.; common salt, 3 oz. Mix well.

### Replacing a Knob on an Aluminum Kettle Top

IF the knob is broken from an aluminum kettle cover, a large ragged hole is left which will render the kettle practically useless. If the edges are filed smooth



Two washers and a stove bolt used to repair the broken cover of a kettle

and two tin roofing-caps are used as washers, one on the underside and the other on the outside of the cover, and the knob fastened with a small stove bolt, as shown in the illustration, the kettle will be as good as new.

### Grooves Necessary in Giant Motor-Truck Tires

FOR several years solid rubber tires for motor-trucks were never made wider than 7 in., and where necessary to have them wider, a twin or dual tire was used on each wheel. Tires of greater width than 7 in. gave poor results as the tread would separate from the base. Tests have proven that this separation was caused by insufficient vulcanizing of the rubber near the base. Increase in the width called for an increased thickness of the area and this would not vulcanize uniformly. If

FRAGMENT OF HEAT IN VULCANIZING PROCESS



Three grooves to cure tires properly

the rubber near the base of the tire was properly vulcanized it usually happened that near the tread would be overcured and brittle, while if the latter was properly vulcanized the portion near the base would be soft and putty-like.

A great deal of experimenting solved the problem by forming three deep grooves in the tread surface. These grooves permit the heat for vulcanizing to reach all portions of the tire area.

### Making Screws Hold in the End Grain of Wood

THE very nature of the grain running lengthwise makes it exceedingly hard to fasten the threads of a wood screw so that it will hold for any length of time. Where it is necessary to fasten the joints of wood in the fashion shown in the illustration, one of the best methods is to insert a wood pin in a hole bored crosswise with the grain.

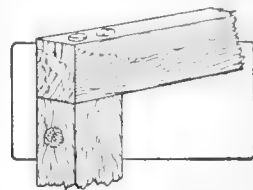

A wood pin in a hole bored across the grain

The size of the pin will depend on the joint and on where it is used. In fitting the pin to the hole make it large enough to drive in snugly. A little glue applied to the surface will fasten it in place.

### Adjusting a Storm Sash from the Inside of a House

BY applying the following method, a storm sash may be adjusted from the inside of a house. Two pins are driven into the top rail of the sash and holes provided in the window casing at the top to

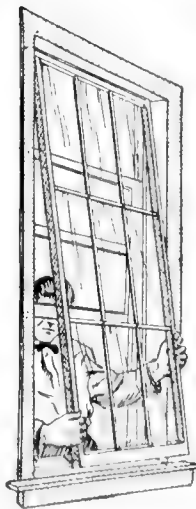

Storm sash applied from the inside



receive them. The pins may be made either of 3-in. nails with their heads removed or short lengths of dowels. The location of these pins is shown at *A*. To install the window, push it through the opening left by raising the lower sash, set the pins

in the holes and pull the bottom in place. The lower part is held with two small hooks as shown at *B*. Storm sash provided with holdings of this kind require no ladders to put them in place on upper windows.

**A Home-Made Photographic Copying-Stand**

**T**O PREPARE the camera and board so that copying may be done properly is a difficult task for the amateur, as the surface of the picture to be reproduced must be in a vertical plane and exactly parallel to the camera lens. The lighting of the picture must be considered and the task of adjusting all parts to meet the conditions grows harder as each successive step is taken in copying. A stand is most desired, but the arrangement shown in the sketch will suffice and it can be used on the work table. It is made of a board for the base, 4 ft. long and 5 in. wide, mounted on supports that are 2 in. wide, one at each end, cut as shown. These supports are strengthened with a bracket fastened on the underside of the baseboard. It is best to use wood screws for holding the parts

board it is to hold and the closeness of the fit. It takes the shape of a box with both ends and one side removed, or it can be used with both sides. Two strips are fastened on the upper side so that a space is formed between them to admit the edge of the board to prevent it from tipping backward and forward.

Both camera and sliding-holder are easily adjusted and the whole stand may be moved about to get the best results for lighting. The finish of the base should be without paint or varnish—just a smooth, planed board so that the camera and holder will slide easily.

The board may be removed and the holder used to support a vase or other similar article which it may be necessary to photograph. It is well to have the

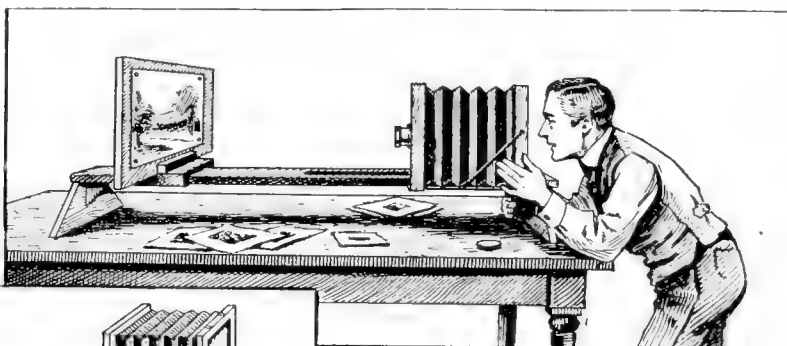

Camera and easel base made with low supports so that it sets on a table

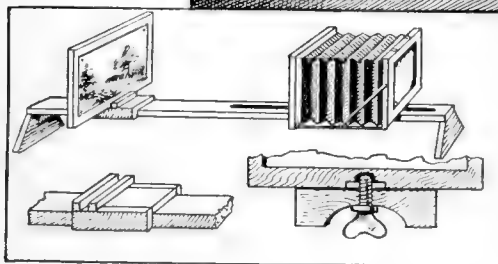

together, gluing the joints before putting in the screws. A slot is cut in the center of the baseboard at one end, which extends about halfway to admit the thumb-screw used to fasten the camera to the tripod. If the baseboard is cut from material more than  $\frac{3}{4}$  in. thick it may be necessary to cut the wood out from the underside so that the thumb-screw will enter the camera socket. This cut-out recess is shown in the cross-section.

The copying-board is made detachable from the sliding-holder, as well as the holder from the base. The size of the holder will depend largely on the

holder long enough to provide a place in front of the board upon which to set these objects; then a sheet of plain or tinted paper can be attached to the bottom and curved to form a suitable background with a continuous foreground.

**A Snow Shovel That Prevents the Snow from Sticking**

**V**ARIOUS kinds of shovels have been tried and I have greased them to keep the snow from sticking to the surface, but at no time have I ever had so much satisfaction shoveling snow as when using the regular potato or manure fork. Such a fork will take up as much snow at a time as a scoop shovel, while, no matter how wet the snow, it never carries any superfluous weight of snow back and forth.—PAUL R. STRAIN.

### A Makeshift Syphon Fashioned from Paper Tubes and a Thread Spool

THE following plan proved very successful for drawing wine from a jar without disturbing the sediments, at a time when a syphon was not available. A  $\frac{1}{4}$ -in. hole was bored in the side of a common spool on a 45 deg. angle with the hole already running through the spool. I then rolled a couple of sheets of clean paper into tubes and inserted one into the hole just bored and the other into the other hole, making the syphon in the form of an inverted V. The hole in the top of spool was tightly corked and my makeshift syphon was ready for business. That it proved satisfactory goes without saying. Such a syphon can be utilized in photography for removing the clear fluid from mixed chemicals.—EDWIN R. MASON.

### Utilizing the Waste Heat from an Open Fireplace

ALMOST all the heat produced in a fireplace located in a wall between the living-room and the dining-room of a certain house was used for heating the water for the bath and to heat the dining-room in the following manner: A coil of pipe was put in the opening just back of the flames

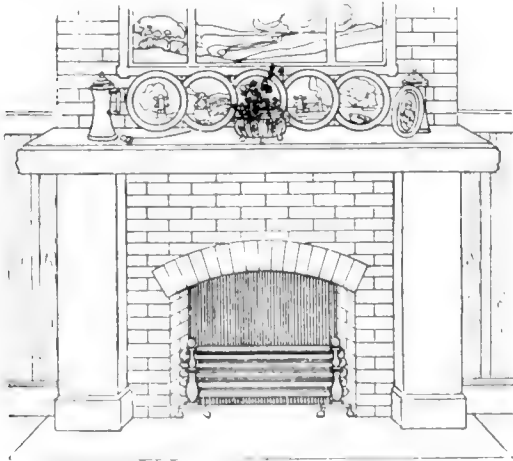

A coil of pipe is run in the fireplace to heat the water in the range boiler

and connected to a range-boiler. Pipes were run from the boiler to the bath and sink. Instead of a solid brick back to the fireplace a thin wall of metal was inserted in the dining-room side. A false mantel with open grill-work covered the metal wall. Above the grill-work and on the

mantel was placed a fireless cooker, built into the chimney-breast directly against the brick and lined with asbestos. The

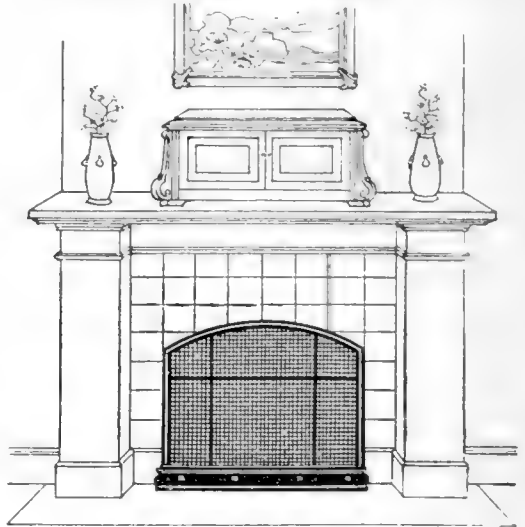

On the opposite side and in the dining-room is a false fireplace with a thin backwall

exterior finish of the cooker was made ornamental so that it did not look at all like a cooking utensil.—MRS. H. COLDWATER.

### Eliminating Trouble with Toilet Flush-Tanks

MUCH trouble is experienced with toilet flush-tanks where the chain pull is installed. When the bowl is flushed the chain is nearly always pulled down and outwards instead of straight down, as it should be pulled. When the chain is pulled outward it will eventually throw the inner working parts out of line, thereby preventing the valve from closing tightly. A good way to avoid this is to turn a screw-eye into the bottom edge of the flush-box directly under the arm to which the chain is fastened, running the chain through this screw-eye. This prevents the chain from being pulled outward when flushing the bowl.

### Aluminum Alloy for Patterns and Core Boxes

A MIXTURE of 130 parts aluminum, 25 parts zinc and 10 parts ferro-zinc is an excellent alloy from which to make patterns and core boxes. It also makes a casting that is strong and light and at the same time inexpensive. It is easily mixed in the crucible and the resultant metal has a very attractive smooth finish.

# Building a Speedy Ice-Yacht



ANY one who is at all handy with tools and has the ability to build any kind of a boat, will find it easy to construct a first-class ice-yacht from the sketches and scale drawings given. This particular type of craft is a splendid all-round model and is known among ice-boat men as a "wire-boat," because the wire guys run from end to end. This form of construction makes a very rigid and strong boat, capable of standing up in the heaviest weather, yet showing plenty of speed in light winds. The construction is clearly shown in the illustration.

The details for making the backbone or keel are given in the drawing. It is necessary that only the very best quality of lumber should be used, clear white pine being the first choice. Spruce however, makes a very good substitute, and white cedar is also used to some extent,

but it must be the clear white cedar of the North; southern cedar is less durable for this purpose. The backbone is 25 ft. long, 10 in. wide in the widest part and 4 in. thick throughout. The stern-end of the timber is cut on a bevel as shown, while the forward end is finished with a 6-in. round taper.

For the runner-plank, spruce 2 in. thick should be used. First quality stock, free from knots or checks must be used. A plank 12 ft. long, 12 in. wide and 2 in. thick will be needed. Taper the plank to 10 in. wide at the ends. The runner-plank is solidly fastened to the underside of the backbone with a  $\frac{5}{8}$ -in. carriage-bolt in the center and two U-shaped strap-bolts on each side.

In bolting the runner to the backbone it is very important to fasten it at absolutely right angles. Any departure from the perfect angle, however slight it may be, is sure

to injure the sailing qualities of the boat. To insure accuracy, it is a good plan to clamp the two pieces together in the correct position with two or three heavy

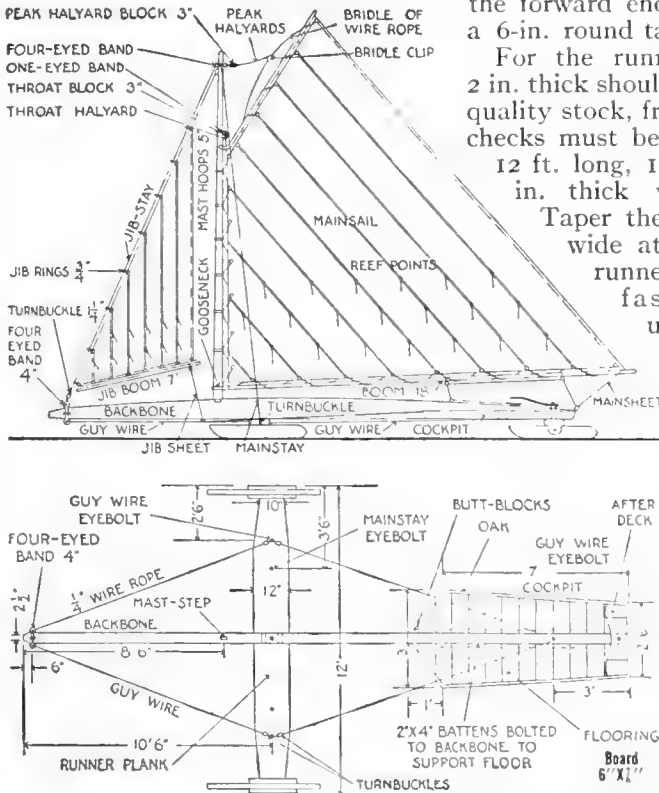

Elevation and plan of the ice-yacht with dimensions and parts named showing their relation to one another

clamps, before boring the holes for the bolts. The U-strap bolts will need to be made by a local wheelwright or blacksmith, who will no doubt loan the clamps.

Full details of the runner-plank construction are shown in the drawing. The outside runner-guide is bolted to the underside of the runner-plank 1 in. from the outside edge. Two pairs of guides will be required and they should be made from straight-grained oak, 14 in. long, 4 in. wide and 1½ in. thick. From the inside of the first guide measure off 1¾ in. and bolt the second or inner guide across the plank parallel with the first one. This will leave a slot 1¾ in. in width between the guides

7 in. wide and shaped as shown. The runners are shod with wrought-iron shoes made of 1-in. iron, and solidly attached to the oak runners by long flat-head screws, which are countersunk. Round iron is generally used for the shoes, and that the iron may be rigidly clamped in place, a slot or groove is cut in the bottoms of the runners to receive it. However, half-round iron may be used, if desired. That the shoes may "bite" the ice well, the running surface is filed to a V-shape as illustrated. When doing this work, considerable care must be taken to make the filed edge perfectly straight, for any waviness is certain to cause the craft

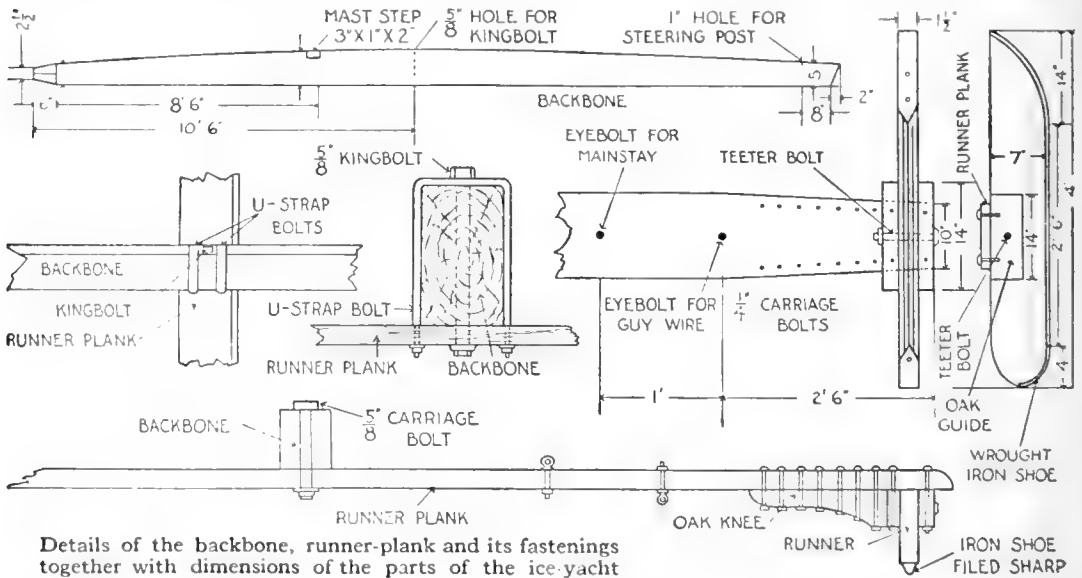

Details of the backbone, runner-plank and its fastenings together with dimensions of the parts of the ice-yacht

in which to insert the runners later. Carriage bolts ¼ in. in diameter are used for fastening the guides in place. To further strengthen the head of the plank, an oak knee is butted against the inner guide and bolted to the plank as shown. Make the knees about 18 in. long and the same width and thickness as the oak guides. When bolting the guides in place, take particular care to have them absolutely at right angles to the plank, otherwise the boat will "track" poorly, and prove slow. In order to get this right, clamp the pieces in place before boring the bolt-holes. After all the nuts are set up on the bolts, peen over the edges of the bolt-ends so that the nuts will not be lost should they happen to loosen up at any time.

The side runners are sawed from straight-grained white oak, 1½ in. thick, 4 ft. long,

to slide and deviate from its course.

The completed runners are inserted between the oak guides and "hung" to the runner-plank by means of a ½-in. teeter-bolt. The usual practice is to hang them in the center of the runner surface as shown, leaving a space of about ¾ in. between the top of the runner and the runner-plank. In boring the hole for the teeter-bolt, make it a comfortably snug fit, so that the runner will move on the bolt as upon a pivot.

The rudder, or steering runner, is made of 1½-in. white oak, 3 ft. long and 5 in. wide. It is shod with wrought-iron the same as the side runners. Complete details are given in the drawing. The rudder-fitting and tiller can be made by any ironworker or local smithy. To afford a good grip for the hand, the end of the tiller may be

wound with a generous length of fish line.

Details of the cockpit are given but this may be made of any size, although the 7-ft. cockpit shown will prove very satisfactory. The flooring is made by fastening spruce boards to the underside of the backbone with  $\frac{3}{8}$  by  $2\frac{1}{2}$ -in. lag-screws. Around the outside of the flooring, a  $\frac{5}{8}$ -in. combing is screwed. This combing should be 4 in. wide and may be put on in straight pieces by merely mitering the joint as shown, carrying the forward pieces to form a V-shape. Butt-blocks screwed on the inside of the combing at the miter-joint and where the combing butts against the side of the backbone, will make a neat and strong fastening. However, cockpits are made in various shapes, sometimes almost oval and again with rounded corners. If this is desired, the oak board must be thoroughly steamed and clamped in place while hot and moist, otherwise it will be sure to splinter while it is being bent.

As shown in the drawing, two pairs of guy-wires are used to support the runner-plank and keep it at right angles to the backbone. Wire rope  $\frac{1}{4}$  in. in diameter is used. For the forward guys two lengths of wire rope 12 ft. long are required, and two lengths 13 ft. long for the rear guys. In order to set the guys up taut and keep them so a  $\frac{1}{4}$ -in. turnbuckle is used at the end of each guy where it is secured to the eyebolt in the runner-plank. On the taper of the fore end of the backbone is wedged a 4-eyed band 4 in. in diameter. In the two side eyes fasten one end of the two fore guy-wires. This may be done by making a single hitch knot through the eye and seizing the end to the standing part of the rope with marlin or other strong twine. Another way is to clamp the ends with a metal clip sold at hardware stores as a "wire rope clip." To the other ends of the fore guy-wires, fasten the eye of the turnbuckles and hook the latter into the eyebolt in the runner-plank. A heavy screw-eye is turned in through the flooring into the backbone 3 ft. from its rear end, and into this the ends of the rear guy-wires are fastened. The other ends of the rear guy-wires are lashed into the eyes of turnbuckles, and the latter hooked into the eyebolt in the runner-plank, in the same way as the fore guy-wires. By screwing up the turnbuckles, a strong and flexible stay is provided for the frame.

It is the usual practice among ice-boat builders, to use a second guy-wire to stay

the forward part of the backbone. For this an 11-ft. length of  $\frac{1}{4}$ -in. wire rope is required. Fasten one end in the lower eye of the band on the fore end of backbone

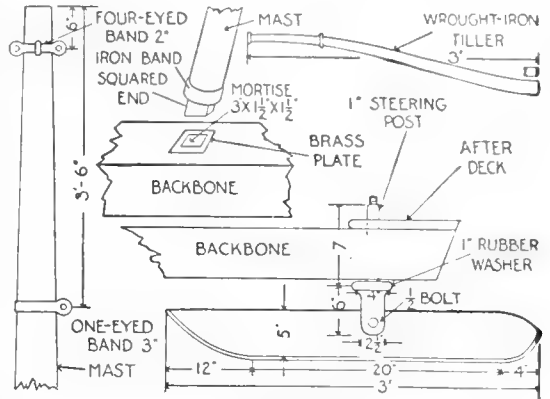

Details of rudder-runner, tiller, backbone and mast connections and of the mast fittings

and run it to a screw-eye turned in the center of the runner-plank and up into the backbone. Connect the end to a turnbuckle and set this guy up taut. To keep the wire from the backbone, a V-shaped spreader is employed, as shown in Fig. 1. This is quickly made from strap-iron by a blacksmith, the length of 6 in. being about right. This spreader is shown in the drawing of the fittings.

The mast is  $15\frac{1}{2}$  ft. long,  $4\frac{1}{2}$  in. in diameter at the base or foot, and tapered up to 3 in. in diameter where the single-eyed band is wedged on for the throat-halyard block,  $3\frac{1}{2}$  ft. from the top. The remainder of the mast is tapered to 2 in. to the end. Hickory cannot be excelled for mast and spars, and the wood is not difficult to round into shape with a sharp plane. The easiest way to do this is to first plane the mast to the desired taper in the square, then plane off the four corners to make it six-sided. Reduce the six corners to make it nine-sided. By planing off again the stick is almost round, and may be scraped smooth with a steel cabinet scraper.

The boom is 18 ft. long,  $3\frac{1}{2}$  in. in diameter in the center, and tapered to  $2\frac{1}{4}$  in. at the mast end and 2 in. at the other end. The gaff is 8 ft. long,  $2\frac{1}{2}$  in. in diameter in the center, and tapered to  $1\frac{7}{8}$  in. at the mast end, and  $1\frac{1}{2}$  in. at the other end. The jib-boom is 7 ft. long,  $1\frac{3}{8}$  in. in the center and tapered to  $1\frac{1}{4}$  in. at each end. The end of the gaff is squared



and a pair of oak jaws bolted or screwed to it, to keep this spar close to the mast. These jaws may be purchased with the other fittings, or sawed out of  $1\frac{1}{4}$ -in. oak.

For making the sails, heavy unbleached cotton duck 8 oz. in weight is the most satisfactory. The breadths of cloth are first sewed together by lapping one edge over the other for about  $\frac{3}{4}$  in. with each edge stitched close. The narrow-lapped or bighted effect may be gained by folding over a hem and double-stitching the same

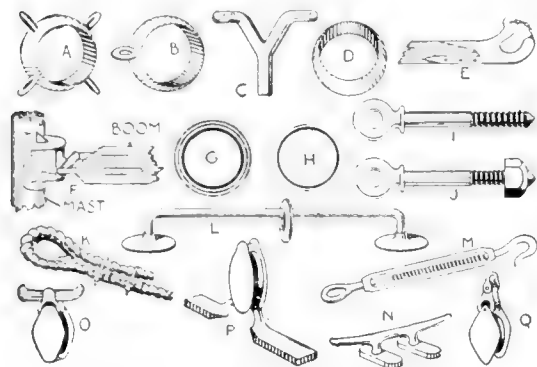

The small fittings required to connect the parts of the ice-yacht described

way as the regular seam. The laps must, of course, run parallel with the leach or after side of the sail, as shown in the sail plan. To make the sail strong and serviceable, it is the usual practice of sail-makers to sew  $\frac{1}{4}$ -in. rope (tarr'd bolt-rope is the best) all around the sail. For hand sewing on canvas, a diamond-pointed sail needle and a sailor's palm will be required to force the needle through the rope and cloth. The stitch used is simple overcasting. The seams of the sail itself may be stitched on the sewing-machine, but the hand-sewn sail is the strongest. At each corner of the sail, sew on a semicircular path to reinforce the sail at these points.

The sail is attached to the mast-hoops and gaff and boom through grommets. An easy way to make these grommet-holes is to procure about 3 doz.,  $\frac{3}{4}$ -in. galvanized iron grommet-rings. Punch a small hole in the sail where the grommet-hole is wanted, place a ring on each side of the hole and sew the ring to the sail by means of an overcasting stitch, using waxed sail twine and a sail needle. The reef-points may be simply sewed to the sail, but the sailor's way of doing this, is to sew in  $\frac{1}{2}$ -in. grommet-rings to reinforce the sail. The reef-points are 6-in. lengths of cotton rope.

About  $\frac{1}{8}$ -in. twine may be used. The sails should be cut at least 6 in. shorter than the spars so that plenty of room is left for lashing them after the sails have stretched, which they are certain to do.

The mast is stepped by squaring the foot or heel as shown. To prevent the end of the spar from splitting or checking, drive on an iron band or ferrule. To do away with wear of the mortise, cut in the backbone to receive the mast. It is a good plan to face the hole with a piece of sheet brass.

The mast-head is rigged as shown,  $3\frac{1}{2}$  ft. from the top. A single-eyed band with eye to the rear or on the after side of mast, is wedged on the mast-head. The 4-eyed band is wedged on the mast 6 in. from the top as shown. In the forward eye of the top band, lash the end of the  $\frac{1}{4}$ -in. wire rope used for the jib-stay. In the after eye, hook the 3-in. pulley-block, to be used for the peak-halyards. In the two side eyes, lash the ends of the  $\frac{1}{4}$ -in. wire rope used for the mainstays. In the single-eyed band, hook the 3-in. pulley-block for the throat-halyards, and in the eye in the top band, underneath the jib-stay, hook the 3-in. block for the jib-halyards.

Each end of the stay is lashed to the eye of a turnbuckle, the jib-stay being carried down to the top eye in the band on fore end of backbone, and the two side guys, or mast stays, carried down to the eyebolt in the runner-plank on each side of the mast. Before stepping the mast, slip on the six mast-hoops, and the eight jib-rings, and reeve the halyards through the blocks on the mast-head.

The rigging may now be set up taut by screwing up the turnbuckles. The gaff is kept close to the mast by its jaws. To prevent any possibility of the jaws becoming unshipped—which is a common occurrence—it is customary to bore a hole through each end of the jaws and run a wire through. That the jaws may slide up the mast easily without binding or jamming, string a few round hardwood beads on the wire after the jaws are in position around the mast. These loops are known as parrels, and the beads are made of lignum-vitae. The  $\frac{1}{2}$ -in. size is suitable for the purpose, and six beads will suffice.

The boom is fastened to the mast by means of a fitting called a gooseneck. These fittings are of various models, a good

one being shown at *F*. The mainsail is secured to the mast-hoops through the grommet-rings, by seizing them together with a few turns of marlin (which is strong rope-yarn) or any strong twine. The boom and gaff are laced to the spars with  $\frac{1}{8}$ -in. cotton cord, running the cord through the grommet-holes and around the spars. The jib is attached to its stay by seizing through the grommet-rings to the jib-rings and to the jib-boom by lacing with cord.

A good way to attach the jib-boom to the stay is to screw an eyebolt in the end of the jib-boom and connect this with the eye in turnbuckle with a heavy split ring. This will hold the foot of jib in place, and allow the jib-boom to move freely. The halyards should of course be lead aft to the cockpit where the skipper can reach them without leaving the cockpit. The best way to do this is to screw a double or two single pulley-blocks on the runner-plank 12 in. from the mast, for the peak and throat-halyards of the mainsail, and a single block of the same size on the opposite side of the runner-plank, for the jib-halyards. The halyards may now be led aft and belayed to a cleat, screwed on each side of the backbone in the forward end of the cockpit.

The rope for pulling in and letting out the mainsail—known as the mainsheet—is best rigged up as shown. An iron rod, known as a traveler, is screwed on the after deck back of the rudder-post, and a pulley-block is lashed to the ring on the traveler. The rope is fastened to the end of the boom, and is led through the block on the traveler, up to two blocks lashed to the boom and down to a block screwed to the top of backbone, which affords a splendid leverage, without putting the blocks in the way of the steersman's head when he is going about.

The rope for controlling the jib—called the jib-sheet—is lashed to the end of jib-boom, thence led to a pulley lashed to the guy-wire, and aft to the cockpit.

All the fittings required are illustrated in the drawing and may be purchased from dealers in marine hardware or yacht supplies. The galvanized iron fittings are to be preferred to the common black iron, owing to their non-rusting qualities. The U-strap bolts, the V-shaped spreader, the rudder fittings, and the shoes for the runners, can be made by any blacksmith, and will not prove expensive.

As a well-built boat of this type will last for many years of hard sailing, the craft should be painted, for the sake of appearance as well as to preserve the woodwork. Red or black paint gives a better effect than other colors, but this detail is one of personal choice. An attractive way to paint the boat is to finish the front of the backbone up to the runner-plank in spar-varnish and the rest of the boat aft in paint. The runner-plank may be painted out to the guy-wire eyebolts, and the heads of the plank and the runners finished in varnish. The rudder-runner may be varnished also. The cockpit is painted, but the oak combing will prove attractive if finished "bright"—that is, in varnish. The mast and spars should be well sandpapered and finished in two or three coats of spar-varnish. Bolt-heads and other fittings may be touched up with aluminum or bronze.

#### Preventing Exposed Water-Pipes from Freezing

**E**XPOSED water-pipes are apt to freeze in winter, causing much annoyance, which may be prevented by covering them with the following mixture: To a solution of thin boiled starch add sawdust until the mixture forms a thick paste. A fine sieve may be used to clear this sawdust from lumps.

Heavy cord is first wrapped around the pipe, spacing the turns about  $\frac{1}{2}$  in. A  $\frac{1}{4}$ -in. layer of the mixture is smeared on and allowed to dry; then a second layer is put on and smoothed up. The string acts as an anchor to make the coating adhere to the pipe closely. Whitewash or paint may be used to give a finish for inside pipes; but for outside work cover the coating with hot tar. If it is desired to have a very neat covering, wrap the sawdust coating with cloth or canvas, applying it in narrow strips like a bandage, and painting the outside surface. An even coating of the sawdust is necessary when covering with cloth.—THOS. W. BENSON.

#### How to Handle Sulphuric Acid with Safety

**D**ANGER is often encountered in emptying sulphuric acid from a carton into a small bottle. Procure a rubber stopper that will fit the neck of the carton. Make a hole in the stopper to receive a piece of rubber tubing. Pour the acid through this.—J. H. CASSIDY.

### A Puller to Remove Steering Wheels on Automobiles

A SIMPLE device for removing a steering wheel from its post is shown in the illustration. It is made of metal 18 in. long, 1 in. wide and  $\frac{1}{2}$  in.

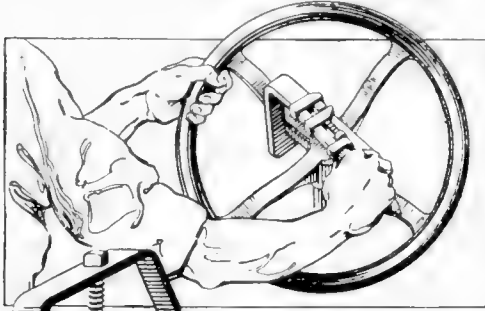

The puller and its application on a steering wheel

thick. The bar is bent as shown and a hole drilled and tapped for a  $\frac{1}{2}$ -in. screw in the center. The end of the screw is pointed to fit into the center of the steering head post. The two bent ends are hooked under the cross-arms of the steering wheel and the screw-end set in the center of the post. It is only necessary to apply a common wrench to draw the wheel from its place quickly.

### Milk as a Lubricant for Drilling in Copper

SOME years ago a man came into the writer's shop with a copper tube having a  $\frac{1}{8}$ -in. wall. He wanted fifteen holes drilled into this tube with a No. 80 drill, which is somewhat smaller than a pin. The writer had a dozen drills of this size on hand so one of them was placed in the chuck and the drilling began. That is, it was intended that it should begin. But no sooner did the drill touch the tube than it snapped off like so much glass. Another drill was tried using oil as a lubricant, with the same result. Then soap water, different kinds of oil and every known lubricant were tried but without avail. Finally only one drill was left with not even one hole in the tube to show for the destruction of the other eleven. It seemed a hopeless case. Then as a final resort milk was tried and greatly to our surprise all the holes were drilled with

the last drill. This sounds incredible but it is true, nevertheless. The milk contains just enough oil to act as a lubricant and enough water to act as a cooling agent. This combination of oil and water cannot be obtained in any other form. Milk is not only useful in drilling copper, but also in working it in any manner.—LESLIE S. LYONS.

### Lubricating the Working Joints of a Pocket Knife

POCKET knives naturally come in close contact with the body and for this reason they become dry and rusty from the heat and perspiration. Necessarily any lubricant must be of some dry material. A very simple and efficient, as well as cleanly method is to use a little powdered graphite on the joints. The graphite may be obtained from the lead of a pencil. After applying it, work the blades a few times to get it into the joints.

### Compressing Automobile Leaf Springs to Bolt Them

THE problem of compressing the leaf springs on a Ford was solved in the following manner without the use of the usual clamp. A large wrench was slipped over the chassis and spring and

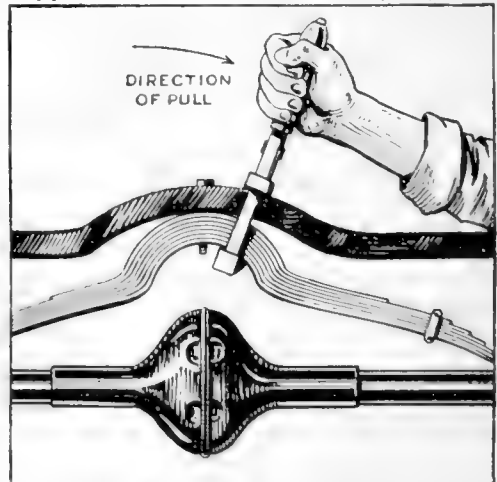

Drawing spring in close contact with chassis frame for bolting it in position

tightened into position, after which the wrench was pulled to the right and the spring was compressed and easily bolted into position. The illustration shows the method of procedure.

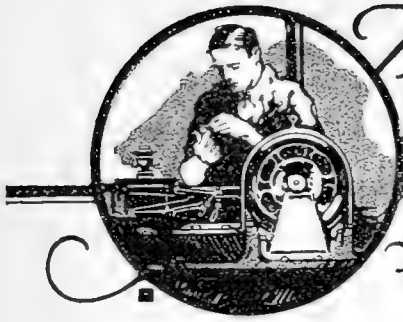

# The Amateur Electrician

## And Wireless Operator

### Making an Electrically Heated Soldering Iron

AN electric soldering iron is not a tool for the inexperienced person to build; however, with extreme care and the proper materials, a very good tool can

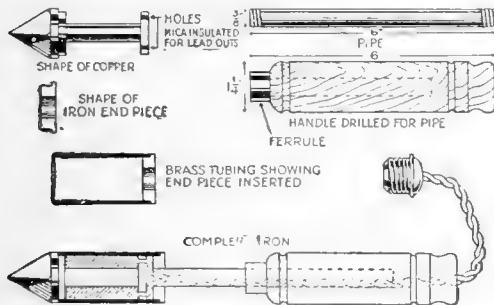

The necessary parts for the construction of an electrically heated soldering iron

be made. An improperly designed and constructed electric soldering iron may often result in fireworks of a dangerous variety. The home-made kind will be somewhat cheaper than one of a similar size and like heating element and just as good results can be had from its use.

The handle is turned in a lathe from maple stock to the dimensions given in the diagram. A hole is bored axially through the handle and a 6-in. length of  $\frac{3}{8}$ -in. gas-pipe forced into it. Two feet of asbestos-covered copper wire should be led through the pipe and handle and to an attachment plug. The other terminals of the wire are attached to the resistance winding. The winding, whose resistance causes the copper head to be heated, consists of 18 ft. of No. 30 nichrome wire, which is wound in six layers on the copper spool. Each layer should be well insulated with leaf mica, and the outer layer well covered. A protective copper tube is pressed over

the winding, covering it completely. The dimensions of this tube and of the copper are given in the drawing. Care should be taken that the wire does not come in contact at any place with the metal parts. Without a rheostat the iron will consume about 100 watts.

### An Electric Burglar Alarm Attached to a Door-Lock

A BURGLAR alarm which is operated when a door is opened can be constructed by screwing a spring *A* in the back wall of the mortise of the door jamb, bending it so that it makes a contact with the lock-bolt, as indicated in the sketch. The spring forms one contact and the iron covering the door, the other. The two contacts thus formed are connected to bell magnets *B* through a closed circuit battery. The other connections are shown in the diagram.

When the door is locked the bell *C* will not ring; but when the bolt is

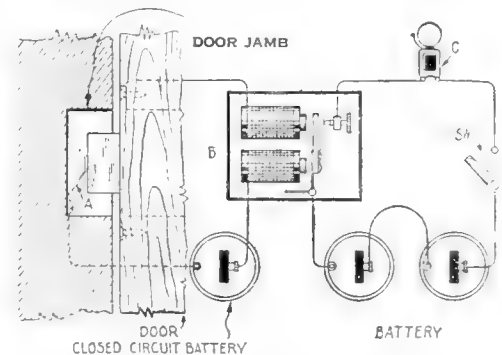

Spring contact in a door-lock for sounding a burglar alarm when the door is opened

disengaged from the spring the circuit is broken, allowing the armature of the bell magnets to spring back, closing the circuit.—CHARLES W. CHRISTMAN.

### A Dead End Switch of the Multiple-Point Type

DEAD end switches usually bring to mind the picture of a rotary disk with some sort of puzzling springs and contacts mounted around its edge. The

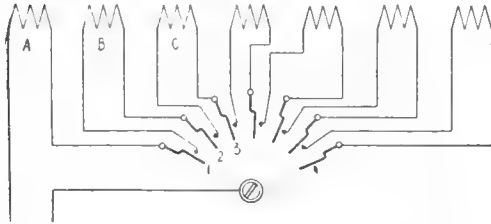
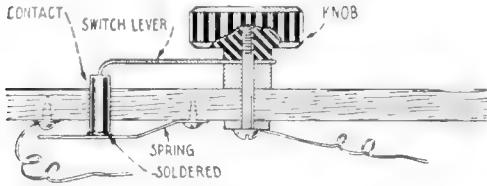

One of the contacts shown in detail and the wiring diagram for the switch

switch illustrated here is, to all appearances, a regular multiple-point type, yet it is doing all that any dead end switch can possibly do.

As will be seen the contacts fit into a hole cut through the front of the case and extend about  $\frac{1}{4}$  in. to the rear. The rear end is soldered to a short spring-brass strip that normally keeps it pushed outward, the end of the strip making contact with a small screw. The switch-lever should be stiff and its edges curved to glide over the points, moving them inward about  $\frac{1}{8}$  in.

The parts are attached to a board of insulation, either wood, vulcanite, slate or hard rubber; the wood, however, is easiest covered.

The operation will be apparent if you keep in mind that the switch-lever breaks the circuit beyond each point on which it rests. Thus, considering the hook-up, should the lever be placed on point 1, it will push the spring out of contact with the small screw, leaving coil A in the circuit, yet breaking the connection to coil B. This operation repeats itself all the way around the contacts, the last one of which requires no extra contact-screw.

Such a switch may be mounted on the secondary of a loose coupler and will greatly increase the sharpness of the tuning. The extra contact-screws are useful in adjusting the distance the contacts extend from the front of the board.

### Making an Emergency Aerial for Wireless

IF there is a telephone line running into the house and the aerial is down for repairs, or for some other reason, fasten a piece of tinfoil over the insulated wire of the coiled telephone wires coming into the house, then fasten the "lead-in" wire to the tinfoil and connect the wire in the usual way to the apparatus. This is a practical stunt, and will not hinder the working of the telephone.

### Intensifying Magnetic Fields for an Automobile Dynamo

IN the ordinary dynamo, the armature moves between the poles of a number of horseshoe magnets, usually arranged side by side. In the illustration the magnets are shown arranged in the usual manner, namely, on opposite sides of the armature, with their similar poles in juxtaposition. The drawings, for the sake of clearness and simplicity, show only four magnets, although as many as 32 can be used.

The magnets are arranged with the four south poles together on one side of the armature, and the four north poles on the other side. Such a disposal tends to straighten the lines of force, thereby intensifying the magnetic field in which

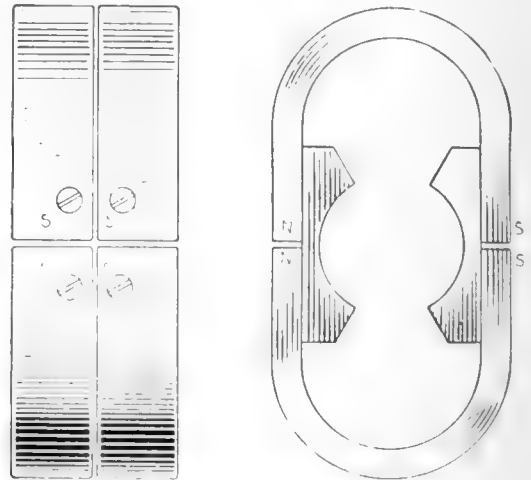

A method of magneto strengthening which is finding much favor with manufacturers

the armature moves. If the opposing magnets are fixed so that their poles meet on the center line of the armature, the magnetic field will be uniformly distributed around this center line.

# How to Become a Wireless Operator

## IV.—Simple Adjustments and Connections

By T. M. Lewis

(Continued from November Issue)

**I**N THE article published last month there were given descriptions of a crystal-detector and stopping-condenser to be made and used in connection with the transmitting set of the October article, for sending wireless messages over a distance of a mile or thereabout. Both the detector and the condenser are of types which can later be used in receiving stations which will pick up the messages from large commercial or government plants not only nearby, but hundreds of miles away. With the small sender using a spark-coil, however, the range will be limited to a mile or so, unless the aerials at both stations are large.

### *The Test-Buzzer*

In using a crystal-detector it is necessary to be able to find out instantly whether or not the adjustment is sensitive. When the needle-point bears lightly upon some parts of the crystal, the receiver is sensitive and able to translate messages coming from a distance; with the contact at other points, however, the instruments seem absolutely dead.

Obviously, to be certain that messages can be received effectively, one must be sure that his detector is properly adjusted. The best way to do this, and the way which is used by the professional operators in most large stations, is to take advantage of the feeble signal-waves induced by a buzzer. By setting up a small sending-outfit, such as described in the September issue of the *POPULAR SCIENCE MONTHLY* in the first article of this series, the sensitiveness of the detector may be tested by listening in the receiving telephones and at the same time pressing the testing-key.

Figure 1 shows how to wire up the buzzer, strap-key and dry cell described in the first article. The only difference from the little sender used to signal from one room to another is that the vibrator-contact post of the buzzer is connected to a miniature aerial wire only a foot or two long, instead of to a genuine, full-sized antenna. The miniature aerial is run along the table

about 2 or 3 in. from one of the wires leading to the detector, as indicated in the illustration, Fig. 2.

### *The Change-Over Switch*

In order to shift connections from sending to receiving, there must be provided a good-sized double-pole double-throw knife-switch. The lever-arms of the switch should be at least six inches long, and the

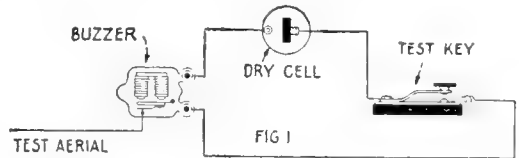

It is necessary to use a test buzzer to find out if the adjustment is sensitive

jaws should be mounted upon a slate, marble, or fiber base a corresponding distance apart. If the switch used is too small it will not have enough insulation to prevent the sparks from the secondary of the induction-coil from jumping to ground by way of the receiving contacts.

A second-hand knife-switch of this size and type can be bought for about one dollar or less; if none can be obtained, it is not difficult to improvise from  $\frac{1}{8}$  by  $\frac{1}{2}$ -in. strip copper, an instrument which will work perfectly. It is only necessary to observe closely the construction of the big knife-switches of the double-throw type, in some central station, and to imitate them as accurately as possible. A number of brief articles have been published in the technical magazines, giving details of construction and dimensions for such switches. The connections for the change-over switch are shown in Fig. 2.

### *The Detector-Protecting Switch*

When the wireless station is completely equipped with detector and spark-coil, it is essential to make some provision which will protect the delicately adjusted crystal from the violent impulses set up by the

transmitter. The simplest way to do this is to connect a small single-pole switch (either a knife-switch or a lever-switch of almost any sort will do) directly across the terminals of the detector. In the wiring diagram of the complete station, Fig. 2, the detector-protecting switch is marked *S*; the wires leading from it to the binding posts of the detector should be kept as short as possible; otherwise they may pick up enough current from the sending-spark to "knock out" or destroy the sensitive adjustment of the crystal-detector. When receiving, the protecting-switch *S* must be open, so that the detector can operate to rectify the currents produced in it by the incoming waves. When sending, the switch must be closed. In this position the heavy induced currents are shunted past the detector and the adjustment is not disturbed by them.

### Connecting the Complete Set

In addition to the parts of the receiving station fully described in last month's article, the various elements of the transmitter illustrated and discussed in October will be needed for a complete sending and receiving station. In fact, a complete set of parts is necessary for each terminal of the proposed wireless "line." The following must, therefore, be at each plant:

#### STATION:

1 Antenna and support	See September and October articles.
1 Loading Coil	" October article.
1 Ground Connection	" September "
1 Change-Over Switch	" above.
Necessary wire for connections.	

#### SENDER:

1 Set of dry or storage-cells	See October article.
1 Sending Key	" " "
1 Induction Coil	" " "
1 Spark-Gap	" " "

#### RECEIVER:

1 Crystal-Detector	See above.
1 Stopping-Condenser	" "
1 Pair of Telephones	" "
1 Test-Buzzer	" September article.
1 Strap-Key	" " "
1 Dry Cell	" " "
1 Detector-Protecting Switch	" above.

The above-named elements of the complete station must be carefully connected together as shown in Fig. 2. It is a good plan to use No. 16 or No. 18 lamp-cord for the wiring of a set such as this. The twisted pair should be separated and

smoothed out, and the single conductors used independently.

It is necessary to keep the transmitting

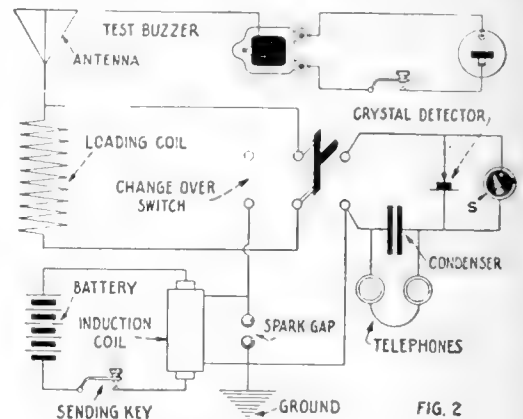

FIG. 2  
The wiring diagram of a complete station showing the location of wireless apparatus

apparatus well away from the receiving instruments. The loading coil, for example, should not be nearer than two feet to the detector, telephones and stopping-condenser. As explained in the second article of this series, the lead-wire from the loading coil out to the aerial must be well insulated if good work is to be done. It is very important that the change-over switch be well insulated, also, for three of its contacts are subjected to the full sparking potential of the transmitter (see the diagram of Fig. 2).

The best plan for beginning work is to have the two antennas, one at each station, as nearly alike as possible. If their form and height cannot be made identical, they should at any rate have exactly the same length of circuit. That is to say, there should be the same number of feet measured from the ground connection up through the spark-gap (but not through the loading coil) to the distant insulated end of the antenna, within a few per cent. In this case, i. e., with the lengths practically identical, the loading coils at the two stations can be put entirely in circuit, and the apparatus will be approximately tuned for the interchange of messages.

If one of the aerials is longer than the other, less of the loading coil should be used at that station than at the other. The exact point to clip on to the wire of the loading coil can be determined only by experiment. By trying every turn, it will be found that some one position is



best both for sending and receiving messages. The wire in the loading coil has the effect of lengthening the aerial; it is therefore perfectly clear that, since it is desired to have both antenna systems of the same total length, less of the loading coil must be included in circuit with the longer antenna wire. The coiled wire is more effective in increasing the station's wavelength than the straight wire in the aerial, however; so less of it needs to be added than one would imagine if he merely considered the difference in the lengths of the two aerial wires themselves.

*Adjusting and Operating*

When the apparatus is set up as shown in Fig. 2, the first thing to do is to put the transmitter into operation. Throw the change-over switch to the left-hand or sending side, and set the spark-gap at about 1/16 in. separation. Making dots and dashes with the key, adjust the induction-coil vibrator to the position which gives a clear, sharp spark between the electrodes of the gap. The spark should be white and snappy, and should sing with the tone of the vibrator. If you cannot get this kind of spark, the set is not working properly and you must go over the antenna insulation to be sure that it is good. If the coil gives a good spark without the aerial connected with it, but won't spark when the antenna and ground are put in the circuit, it is proof that the insulation is not good enough, or that the spark-gap is too wide for the power of the coil. The gap should not be opened more than 1/8 in. at any time.

Having adjusted the transmitter, swing the change-over switch to the right-hand or receiving side. Put on the telephones, see that the detector-protecting switch is open, and hold down the strap-key connected with the test-buzzer. Move the needle-point of the detector around over the surface of the crystal, with light pressure, until the loudest signals are heard in the telephones. The detector is then adjusted and the receiver is ready for use.

The next step is to arrange a sending schedule with your friend who operates the other station. At some fixed time, say four o'clock, let him close his detector-protecting switch, throw his change-over switch to the sending side, and send some predetermined test signal such as "B" in Morse, over and over again, for five minutes. During these same five minutes

have your telephones on, your detector-protecting switch open, your detector adjusted to its best sensitiveness, and your change-over switch in the receiving position. If you have built your apparatus correctly and have set it up in accordance with the instructions of these articles, you should have no difficulty in recognizing the "dash-dot-dot-dot" signals being sent from the other station. Promptly at 4:05 your correspondent should stop sending, throw his change-over switch to the receiving side, open his detector-protecting switch, put on his telephones and adjust his detector. At the same time you should go through the opposite change-over, and begin to send him test signals for five minutes. If all is well he will "pick them up" at once, and when you stop at 4:10 he will be ready to reply to you by wireless that he has heard you; you can then give him the corresponding information and proceed to exchange messages.

You must always bear in mind, however, that whatever your station or his sends out will be heard by other stations which happen to be within range and tuned to the same wavelength. Your signals may even cause interference, and prevent the other stations from reading important messages addressed to them. For these reasons, only such transmitting as is necessary should be attempted; and the Government

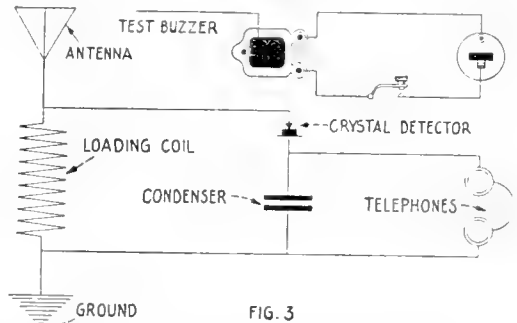

Wiring diagram for a receiver where it is only desired to transmit messages in one direction

regulations as to the use of a pure wave shorter than 200 meters should be strictly observed. As pointed out in the October article, if over half the loading coil is used at each station and if neither antenna is more than 75 ft. in length, the federal requirements will, as a rule, be met.

*Station for Receiving Only*

If it is desired to transmit messages in only one direction, the change-over and

detector-protecting switches may be omitted at the receiver. A loading-coil will be necessary, but since it is to be used for receiving only it may be made as described in the September article instead of highly insulated in accordance with the October description. The transmitter should be connected as shown in October, and the receiver should be wired as in Fig. 3. The comments in this article as to the adjustment will still apply, except that the two switches need not be considered.

The receiving apparatus described here will work one mile easily, and is capable of hearing signals much farther away. In the next article an adjustable receiving set will be discussed, by the use of which signals may be heard from stations located hundreds of miles away.

### A Salt Water Polarity Indicator Made from a Burned-Out Fuse

**A** POLARITY indicator which will determine the positive and negative poles of a direct current line or a battery can be made from a burned-out electric fuse of the cartridge type, a glass tube and two corks. The glass tube, which fits snugly within the fiber cartridge, is cut the same length as the cartridge and a small slot is cut through the fiber as indicated in the drawing.

Short lengths of copper wire should be forced through holes bored in corks which fit tightly into the ends of the glass tube. A diluted solution of salt and water is poured in when one cork is fitted; then the

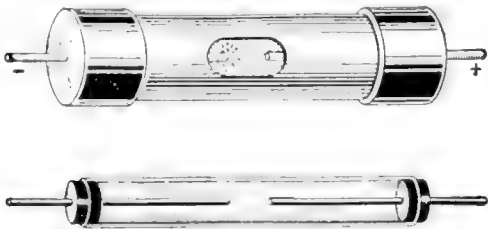

A glass tube with copper wire run through its two corks fits inside the cartridge

other is put in place. The prepared glass-filled tube is then put in place in the cartridge.

When the wire terminals are connected to a direct current, the negative pole will be indicated by bubbles rising from one of the copper plugs. The opening in the fiber permits the bubbles to be plainly seen as they rise.—M. K. GORDON, JR.

### An Electrically-Operated Recording Weather Vane

**I**N YACHT clubs, in laboratories of some sorts, on the farm and other places numerous beyond mention, it is often desirable to know for instant convenience the exact direction of the wind.

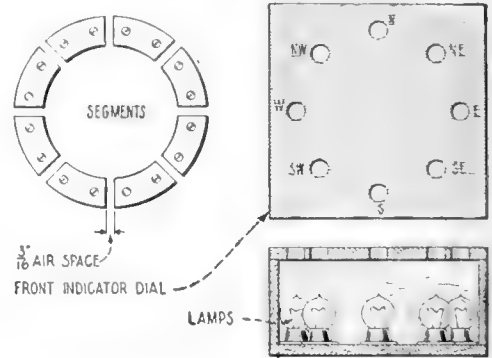

Dial and electric segments for showing the wind's direction inside of a house

In the day-time this information is sometimes difficult to secure owing to the fact that the weather vane is perched on the roof of a building out of convenient eye range. Night necessarily increases the difficulty.

An electric weather vane which will indicate the direction of the wind on a dial conveniently located can be constructed easily. The compass, in the first place, is divided into eight parts, or directions: N, NE, E, SE, S, SW, W, and NW. On the weather-vane dial described, if the wind should be blowing in a direction between two of those indicated—for instance, northeast by north, the two directions, northeast and north will be indicated. Consequently, the vane will register 16 points of the compass instead of only 8 as might be inferred at first thought.

A specially designed weather vane should be erected on a high roof. No vane will register accurately unless it is at a higher altitude than the buildings in the immediate vicinity. This vane consists of the usual light arrow which is pivoted at its center of balance. It can be quickly made from a shingle, sawed or whittled in the shape of an arrow, as indicated in one of the drawings, and then well covered with weather-proof paint or varnish.

The pivot consists of a  $\frac{1}{8}$ -in. round brass rod which passes through a close fitting hole in the top of a seasoned wood

box to a brass cup in the bottom. It is essential that the arrow swings easily on its pivot. The box should be 3 in. in height and 6 in. square. In the bottom of the box two concentric circles are drawn. The annular ring between the circles should measure 1 in. in width. In this ring, 8 curved metal plates are imposed. They serve as commutators. They should be screwed down perfectly flat and the screw-heads filed flush with the metal surface. An air-space of 3/16 in. should exist between the segments. There will be 8 segments altogether. To the outside rim of each of these a 1-ft. No. 18 annunciator, or bell wire is soldered.

A metal arm, which presses down upon the plates with sufficient force to insure an electrical contact, is soldered on the pivot rod a short distance above its base. It is made from spring-brass 1/2 in. wide. To counteract its spring-like action, which otherwise would force the rod and the arrow upwards, a ring or flange should be soldered to the rod immediately below the box cover. The tension of the swinging contact should then be adjusted so that, when the cover of the box is on, the arrow will swing freely, but at the same time the arm will make firm contact with the segments. To the metal socket into which the base of the rod fits, another 1-ft. length of No. 18 annunciator wire should be soldered. The directions of the compass towards which each of the segments point should be indicated by tags on the wires which lead from them. This is important.

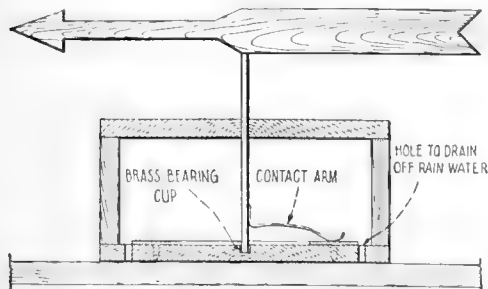

The vane with its slider-arm for making electric connections with the dial

Otherwise, confusion of an amusing variety will result when the dial is connected and the batteries are in circuit. A westerly wind may be registered as southeast, etc. Holes should be bored in the bottom of the box, to drain off rain water.

A cable of 9 annunciator wires, properly

indicated by numbers or letters at the end of each, should be made as follows: Stretch between 2 points, which are as far apart as the distance from the vane to the dial, the

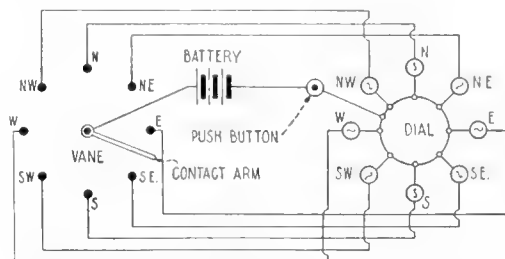

The wiring diagram showing the electrical connections between the vane and the dial

9 annunciator wires. Tar them carefully and while the tar is still soft, wrap the "rope" with insulating tape. The cable should be properly connected to the 9 wires from the vane-segments and contact-arm and led to the room where the registering dial is to be mounted.

This consists of a polished wood box of the same general dimensions as the box on the roof, but with 8 holes each 1 in. in diameter bored in a circle in its front side. A sheet of ground glass is placed against the holes underneath. The 8 directions of the compass are written in black ink on the glass which covers the holes. Under each hole a miniature electric lamp is mounted. The light corresponding to the vane segment which points north is connected to one post of the "north light." The remaining seven segments are connected to their corresponding lights on the dial. The remaining 8 posts of the lamp are connected together and the wire run to one pole of a gravity, or blue vitriol, battery consisting of 3 fresh cells. The 3 cells are sufficient when the cable from dial to vane is no longer than 40 ft. For every additional 10 ft. another cell should be added. If the push button is used, dry cells, not gravity cells, should be employed.

The ninth wire of the cable, the one which leads from the pivot of the vane, is connected with the other side of the battery. If the wind is from a northerly direction, the north light of the dial will be lighted; if in a southerly direction, the south light will show, etc. But if the wind should blow in such a direction that the arm on the pivot rests on two segments simultaneously, two adjacent lamps will light.—G. F. WÖRTS.

### Operating Furnace Checks and Drafts by Electricity

THE device described comprises an actuating lever to operate the draft and check; a relay—a skeleton bell

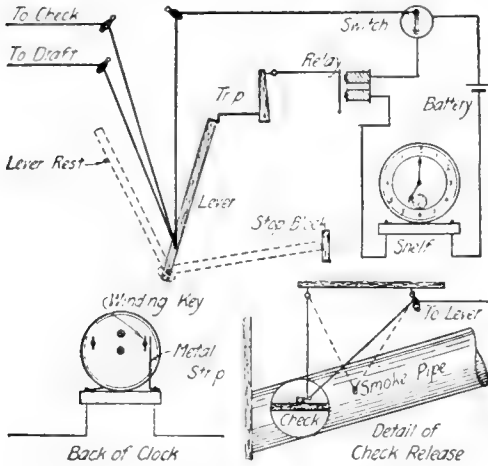

Electrical connections and wiring for an alarm clock to work the furnace check and draft

or buzzer—to release the lever, and a clock to close the electrical circuit at the proper hour. A thermostat may also be used and connected in the circuit. In addition, there is a trigger intervening between the relay and the lever, and a circuit-breaker which effectively prevents loss of power by short-circuiting the battery after the mechanism has been tripped.

Reference to the sketch will show that the circuit-closer consists simply of an ordinary alarm clock, back of which extends upward a metal strip which makes contact with the winding key in revolution as the alarm goes off and forms a circuit through the clock and a turn or two of bare wire on which the clock rests and which leads to the other terminal. The relay is short-circuited so that the armature does not buzz but is simply drawn sharply up to the magnets, thus pulling the trigger lever forward by the wire connection and releasing the lever by raising the bent wire stop.

As the lever falls it not only opens the draft and closes the check, but pulls a third cord which opens a small battery-switch connected between relay and clock, thus preventing current waste should

the winding key chance to remain in contact with the metal strip when the alarm has ceased ringing.

It was found that the check-valve on the furnace in question must be lowered, not raised, to make it draw. The detail sketch shows how this difficulty was overcome by providing a stout wire support for the check-valve which is jerked loose as the lever falls, thus allowing the check to drop to its closed position by its own weight. On a single cell of battery the device will be found to work perfectly.—DEANE S. KINTNER.

### Transformer Trouble in Radio Transmitting Apparatus

AMONG the many sources of trouble by which a radio set's efficiency is reduced, a short-circuit of a few turns in the primary of the transformer is to an inexperienced man one of the most difficult to locate, as well as to find a remedy for. With the primary of the transformer short-circuited, two fundamental principles will explain the cause for the lack of efficiency:

1. In order for the greatest efficiency to be obtained, there must be resonance between the primary circuit and the secondary circuit. It is evident that, if some of the turns are cut out of the primary of the transformer, the two will be thrown out of resonance, since the electrical inductance of the primary will be reduced. This, of course, results in poor working.

2. The other fundamental principle is explained by the potential drop in a circuit. Suppose a circuit, as shown, to be partially short-circuited so as to cut out three turns of the nine turns

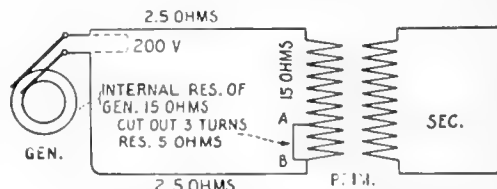

Locating the short circuit in the turns of a primary of the transformer

which constitute the primary of the transformer, as from A to B. The total electromotive force and the internal resistance will remain constant, but the external resistance and current are

changed by the short-circuit. The current is increased, because of the fact that the primary resistance is lowered by the short-circuit, but the number of turns is decreased. Usually the number of ampere-turns (i. e., the number of effective turns times the number of amperes) is lowered by the defect; and since the energy received by the secondary circuit depends on the number of ampere-turns in the primary of the transformer, it is evident that the efficiency is greatly reduced.

Therefore, an increase in the amperage of the primary circuit with a decrease in the reading of the voltmeter, and a large decrease in the energy of the secondary circuit are good indications of a short-circuit in the primary of the transformer. The amount of the variations mentioned will depend on the number of turns cut out by the short-circuit. Often the shorted section will become very hot.

Trouble of this kind is caused by poor insulation, or excessive voltage being applied. It depends upon the extent of the puncture of the insulation as to what is best to be done for repairs. Occasionally the entire primary must be rewound. If only slightly punctured, it is easily fixed by wrapping the wire in the damaged portion with insulating tape. Much care must be exercised in replacing the wire in its original position.

**Practicing the Code Without Using a Buzzer**

FOR the amateur who wants to practice the code and has no buzzer, a good substitute can be made from an old 75-ohm telephone receiver. The receiver is hooked up in series with a 16-c.p. light and a Morse key on a 110-volt

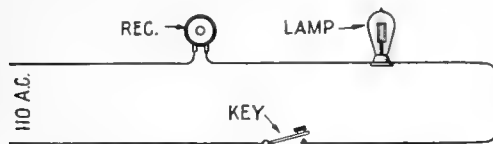

The connections for a key and telephone receiver with an incandescent light

alternating circuit, as shown in the drawing. If the buzz is too loud a smaller c.p. lamp may be used to soften the tone. This method should not be tried on good receivers.—MALCOLM MACURDA.

**How To Take Up the Slack in Your Aerial Wires**

THE difficult job of getting aerial wires stretched evenly can be easily accomplished by utilizing the arrangement shown in the illustration.

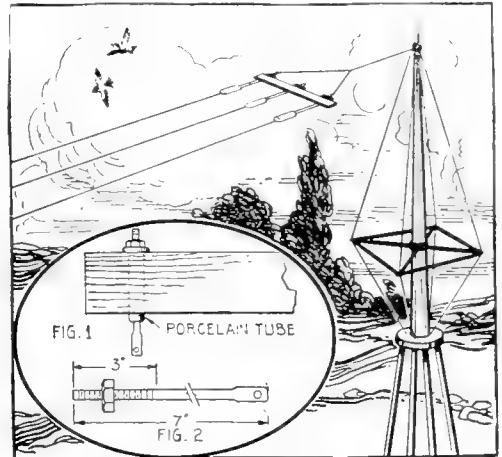

Porcelain tube in cross-bar insulating the bolt for taking up slack in wires

It consists of a porcelain tube—an ordinary unglazed tube about 3 in. long will do—run through a hole in the arm and the holding bolt run through the tube. If bolts having long threads are used, considerable slack can be taken up by merely turning the nut with a wrench. In putting up the wires place the nut in the center of the threaded portion; then it will be easy to shorten or lengthen as desired.—LEE SCHERTZ.

**Canada to Protect Her Parks with Radio Service**

PHILIP E. EDELMAN of St. Paul, Minn., has been engaged by the Canadian Government as electrical engineer to prepare plans for wireless telephony and telegraphy installations over the 7,000 square miles embraced by the Dominion Parks of Western Canada. The installation will be of a new design specially adapted to the difficult mountain service.

The object of the installation is to prevent game trespassing and to afford a means of instantaneous communication for reporting forest fires and calling for aid in territory where ordinary means of communication are out of the question, as is often the case in Canada.

### Preventing Interference of Signals by Amplifying

**A**N interesting patent on a highly selective arrangement for use at a radio-telegraph receiving station is No. 1,173,079, issued in 1916 to E. F. W. Alexanderson. Realizing that the prin-

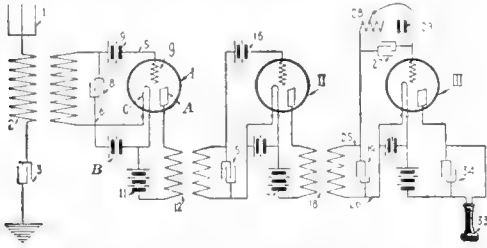

Fig. 1. Inductively coupled circuits in a series of magnifying relays

ciple of selection by tuning to wavelength may be applied several times in the same group of instruments, the inventor has arranged a series of tuned radio-frequency magnifying relays, as shown in the diagrams. The circuits look complicated, but are not very hard to manipulate. Anyone who has two or three audion bulbs, preferably of the double-plate "amplifier" type, will be able to try out a series of experiments along the lines of this invention.

Referring to Fig. 1, it is seen that the antenna **I** passes to earth through the transformer primary **2** and series tuning condenser **3**. The secondary circuit is tuned to the desired incoming wavelength by means of condenser **8**, and connects via wires **5** and **6** to the grid **G** and filament **C** of the first amplifying tube **I**. Battery **9** is in the grid circuit, so as to adjust the relay to its best magnifying condition, and battery **B** is used to heat the filament (or cathode) **C**. Wing circuit battery **11** has one terminal attached to the filament and the other, through the primary of transformer **12**, to the wing or anode **A**. The positive side of **11** is connected to **A**; the proper polarity of the other two batteries of the first tube is to be found by trial.

The second amplifying tube **II** is connected in the same way. Condenser **15** serves to tune the secondary of transformer **12**; batteries **16** and **17** take the places of **9** and **11**, respectively. The plate circuit from **17** to **A** includes the primary coil of the third transformer

**18**, whose secondary is tuned sharply to the incoming waves by means of condenser **19**. Wires **25** and **26** run to the grid and filament of the third vacuum tube **III**, which is arranged to rectify and "detect" the desired signals instead of merely amplifying them. It will be noted that the grid circuit contains a small series condenser **27**, which is shunted by a variable high resistance **28** and a polarizing battery **29**; it is through the co-operation of these three elements that the third bulb is adjusted to rectify the signal waves and so to produce pulsating response-currents in the telephone receiver **33** and condenser **34**.

It is not necessary to use inductively coupled circuits as shown in Fig. 1. If the tubes are interlinked by suitably designed and tuned auto-transformers, as in Fig. 2, the same results will be obtained. By comparing the two diagrams the similarity of the various parts may be seen; the main difference lies in the substitution of single coils and condensers such as **55** and **60** for the two-coil couplers and capacities typified by **12** and **15**. As indicated by the switch in Fig. 2, the telephone condenser **62** (or **34**) is not essential.

The high degree of tuning anticipated by the use of this entire arrangement is gained by the successive selectivity of a series of tuned circuits. If each tuned circuit is adjusted to cause a response to the desired signal ten times as loud as to that which is causing interference, and if the desired signal is amplified five times in intensity by each relay

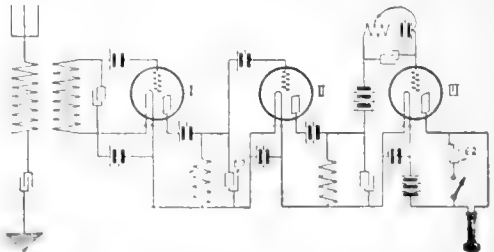

Fig. 2. Here the tubes are interlinked by tuned auto-transformers

tube while the interfering signal is not amplified, it is evident that the final response will contain little of the undesired disturbances. In a normal receiver, having the same selectiveness for individual steps, and not amplifying,

would give a signal ten times as loud as the interference. Under the above assumptions this new receiver would produce a signal thousands of times as loud as the interference. In times of heavy atmospheric disturbance, or when the interference is from powerful nearby transmitters it is probable that favorable adjustment of so delicate an amplifying receiver would be exceedingly difficult to maintain. The device should, however, be useful for many other less trying conditions.

**A New Direct-Current Transmitter for Radio Communication**

**T**HE use of a commutator for producing radio frequency alternating current from direct current, in a wireless telegraph or telephone sending station, is suggested in U. S. Patent No. 1,172,017, issued to R. A. Fessenden in 1916. The method involves making and breaking a battery circuit, leading to the antenna and ground system, several hundred thousand times per second even for the generation of long waves.

It would be very difficult, if not impossible mechanically, to build a rotating commutator which would operate at such enormous speeds, and the patentee therefore suggests that the commutator itself should remain stationary while the flexible contact brush revolves. If the instrument is built with a diameter of about 8 in. and has segments 1/16 in. wide, there will be room for about 400 contacts around the periphery. If the contact brush is driven at a speed of 30,000 revolutions per minute (which is not higher than the velocities reached by De Laval turbines and certain centrifugal machines) electromagnetic waves of 100,000 alternations per second frequency can be generated. This corresponds to a wavelength of about 6,000 meters.

One set of circuits shown in the patent is given in the accompanying diagram. The generating commutator is formed of segments 8 and 7 placed side by side and insulated by the separating material 9. A brush with flexible tip 5, balanced by the weight 6, is revolved by power transmitted through the belt 5a. The antenna 1 is connected through tuning condenser 3 and inductance 4 to the

rotation contact; alternate commutator bars are connected to the opposite terminals of the charging source 13, 14 (which may be either two high voltage generators, or batteries, as shown). The middle point of the power supply is grounded for radio frequency currents, from 15 through the condenser 16 to 2. An additional tuning circuit consisting

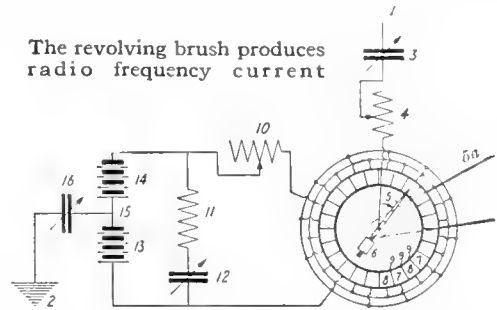

The revolving brush produces radio frequency current

of condenser 12 and coil 11 is shunted across the main power leads, and a variable inductive resistance is placed in circuit at 10.

Assuming that the upper terminal of 14 is of positive polarity, and the lower end of 13 negative, the operation of the transmitter may be outlined briefly by pointing out that each time the contact rests upon a bar or the group numbered 8 the antenna system is charged with a positive pulse; when the brush passes to the next contact this charge rushes to earth and the antenna assumes a negative potential. By adjusting the tuning of the antenna circuit as a whole so as to agree with the rate of interruptions of the commutator, strong radio frequency currents can be set up in the aerial and correspondingly intense waves radiated therefrom.

The diagram merely indicates the basis of the method proposed. Difficulties of insulation would suggest the use of two commutators with separate brushes contacting alternately, one for each polarity of charge. Various other modifications of mechanical structure occur in designing a commutator generating machine for regular use. It seems entirely possible that the structural difficulties in the way of building such an alternator would be less than those involved in radio frequency dynamo machines of other types.



# What Radio Readers Want to Know

## Interesting and Instructive Questions and Answers

### Dimensions for a Receiving Tuner; Effect of Variometer on Wavelength

E. C. S., Deer Lodge, Montana, writes:

**Q. 1.** Please give the dimensions for a 4,000-meter inductively coupled receiving tuner. The secondary winding is to be shunted by a condenser of .0005 microfarads and the primary by one of .001 microfarads. The aerial has a natural wavelength of 450 meters.

**A. 1.** The fact that the aerial has a natural wavelength of 450 meters does not give us sufficient basis to compute accurately the dimensions of the primary winding. We must know the inductance and capacity of the aerial system to work out the problem. The secondary winding may be wound on a form 4 in. in diameter, 7 in. in length with No. 32 S.S.C. wire. The primary winding should be  $4\frac{1}{2}$  in. in diameter, 6 in. in length, wound closely with No. 24 S.S.C. wire.

**Q. 2.** How many meters will the variometer described on page 539 of the October, 1915, issue of the POPULAR SCIENCE MONTHLY add to the wavelength of a receiving circuit?

**A. 2.** We would require more details of the particular circuit in which it is to be employed to answer this question definitely; but off-hand we advise that with the No. 20 wire recommended in that issue it will have but a slight effect on the tuning of a circuit. To be effectual it should be wound with No. 30 S.S.C. wire and will then alter the wavelength of a small set about 250 meters.

### Making a Transmitter for an Amateur Station

C. F. L., Galveston, Texas, writes:

**Q. 1.** Please give the data for the construction of a  $\frac{3}{4}$ -K.W. open core transformer to be operated on 300 volts alternating current at a frequency of 500 cycles. The secondary winding is to deliver 20,000 volts.

**A. 1.** Data for an open core transformer is not available at this writing but it may be possible to supply it at a later date. The following, however, is applicable to a closed core transformer. The core is 9 in. in length,  $2\frac{1}{16}$  in. in width and  $1\frac{1}{2}$  in. in thickness. The ends are  $5\frac{1}{4}$  in. in length and of the same thickness. The primary winding has 98 turns of No. 10 D.C.C. wire wound in two layers. The secondary winding is made in sections and has totally 4000 turns of No. 26 D.C.C. wire. The secondary winding should be split into 5 sections wound either in the form of pancakes or multilayered units of 36 layers each. Appropriate insulation between the windings and the core is required.

**Q. 2.** Give the dimensions for an oil-immersed condenser to be used in connection

with the above transformer. I prefer to use photographic plates 8 in. by 10 in. if possible, and should like to have two sections of condensers in series. I propose to use a synchronous rotary spark-gap with this set.

**A. 2.** We presume that you desire to operate the station at the wavelength of 200 meters and consequently the capacity of this condenser cannot exceed .01 microfarads. If the 8 in. by 10 in. photographic plates are covered with tinfoil 6 in. by 8 in. each plate will have an approximate capacity of .00066 microfarads and therefore 16 plates connected in parallel will give about the required value of capacity. Since you prefer a series parallel connection, you must connect 32 plates in parallel in each bank and then connect the two banks in series.

**Q. 3.** In view of the fact that my aerial is so small, would not a high voltage set of this character carry further than a  $\frac{1}{2}$ -K.W. set using a voltage of 7,000 and a quenched spark-gap of poor design?

**A. 3.** Yes, by all means. The higher potential will enable you to use a greater amount of power with the restricted condenser which the 200-meter wave requires. The fundamental wavelength of your antenna system is about 215 meters and can be reduced to 200 meters by connecting a "short wave condenser" in series with the antenna system, or, preferably, by attaching the lead-in wires to the center of the flat top portion.

### A Long-Wave Tuner

J. L., Scranton, Pa.

**Q. 1.** Where can I obtain the parts and full directions for constructing a 15000-meter inductive coupler of the Navy type, including all the blueprints and necessary diagram of connections?

**A. 1.** We know of no concern which supplies such data and parts. If you have become familiar with the construction and operation of smaller receiving transformers you should have no difficulty in building an apparatus of the sort you wish. The exact dimensions will of course depend upon the size of antenna to be used. For a good-sized aerial, your primary-coil should be of No. 28 wire on a cardboard tube 8 in. in diameter and 18 in. long, taps being taken out at each fifty turns. The secondary may be a 6-in. tube of the same length, wound with No. 36 wire and tapped at each 100 turns. A variable condenser should be placed in shunt to the secondary terminals, for tuning, and a finely-variable loading coil, or variometer, should be placed in series with the primary.

### Lightning Protection, Receiving Coil and Condenser

L. P., Miami, Fla., writes:

**Q. 1.** Referring to the attached diagram, would the apparatus and the connections shown therein be sufficient protection from lightning if located on the outside of a wooden house?

**A. 1.** The National Inspection Code requires that the antenna be connected to earth through a 100-ampere single-blade double-throw switch, and that the earth connection from this switch be made up of at least No. 4 D.B.R.C. wire. Fuses are of no value for protecting the receiving apparatus because even if they should blow the voltage of the next lightning discharge may be sufficient to jump the gap left by the burned fuse. Mount the 100-ampere switch on the outside of the house in an asbestos-lined box and during severe lightning storms totally disconnect the receiving apparatus from the aerial wires.

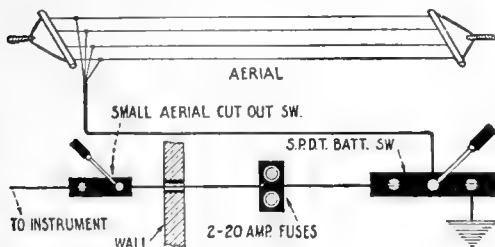

**Q. 2.** In the winding of tuning coils with bare wire, what prevents adjacent turns from actual contact? Is the tube grooved?

**A. 2.** Yes, it is threaded on a screw-cutting lathe. A fine thread is of course required. Sometimes a cord is wound between the turns of bare wire.

**Q. 3.** Please give the dimensions for a small receiving condenser?

**A. 3.** If reference is made to the stopping condenser it may be made up of 20 sheets of tin-foil 2 in. x 3 in. alternated and separated with thin paraffined paper. The entire unit after assembly should be compressed between two strips of wood or hard rubber. See the article by T. M. Lewis in the November, 1916, issue.

### Call Book; One Kilowatt Transformer

F. McM., Fairchance, Pa., inquires:

**Q. 1.** Where may I secure a copy of the new government call book?

**A. 1.** Send 15 cents to the Government Printing Office, Washington, D. C. A new issue was off the press in July.

**Q. 2.** Please give the necessary dimensions for a 1 K.W. closed core transformer, using No. 20 wire on the secondary with the understanding that the secondary winding is to be made in two sections.

**A. 2.** No. 20 wire is too large for the secondary winding of a transformer of this capacity. The complete core for a 1 K.W. transformer when assembled should be 11 in. x 10 in. outside measurements, and the legs 2 in. square. The core is of course made up of a number of pieces of sheet-iron cut to the required length. The primary winding should comprise six layers of No. 12 D.C.C. wire. Approximately seven pounds are required. The secondary winding requires 18 lbs. of No. 32 enameled wire which may be split up into ten sections. It is intended that the primary and secondary windings be mounted on the opposite ends of the core. The primary winding may be insulated from the core by means of eight or ten thicknesses of Empire cloth. The secondary winding may be insulated from the core by means of Empire cloth, enough layers being added to make a separation of at least 3/8 in.

**Q. 3.** Which of the vacuum-valve bulbs do you consider the most efficient, first as a detector, second as an oscillator; namely, the thermotron tubular audion, oscilaudion, electron relay, and audiotron?

**A. 3.** All of the bulbs which you mention work on practically the same principle and are more or less identical in operation. We have no preference and know that good results have been obtained with all of them. As an ordinary detector for the reception of signals from damped stations the ordinary audion bulb is preferred, provided it possesses a certain amount of gas, but as an oscillator for the reception of signals by the "beat" method, the highly exhausted bulbs such as those you mention are to be preferred.

**Q. 4.** What do you consider the best way to use these bulbs, and if possible, give a diagram of connection, first as a detector, second as an amplifier with silicon, third as an amplifier with the Type "A" crystalloid detector.

**A. 4.** The question is rather comprehensive and would require pages for a complete explanation. Circuits of this type are fully covered in the book "How to Conduct a Radio Club." A copy of this book may be purchased from the Book Department of this magazine at cost of 50 cents. Several types of oscillating audion circuits are described.

**Q. 5.** Can you give me the wavelength and the hours of operation of high power stations within my range other than Arlington and Sayville?

**A. 5.** With a long distance receiving set responsive to wavelength up to 8,000 meters, you should be able to hear the Naval Station at Lake Bluff, Ill., and another government station located at Darien, C. Z., Isthmus of Panama. The hours of operation are irregular but they may be heard at intervals throughout the day.

# Plans of a Small Modern Dairy Barn

It costs only \$500 and it can be enlarged at any time

By W. E. Frudden

**I**F the dairy business is started with only a few cows and it is expected to increase the herd from year to year it will pay to adopt the barn plans shown in the illustration. If desired the barn may be

of cinders which will aid in keeping it dry.

The construction is simple, but it is carefully planned to give the proper amount of air space and window surface for each cow and to provide the most convenient

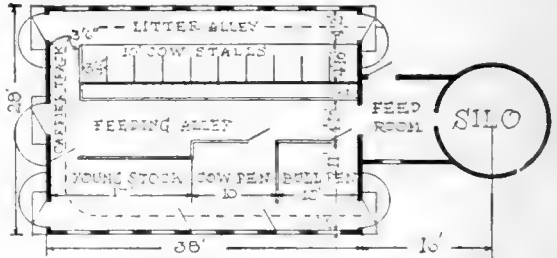
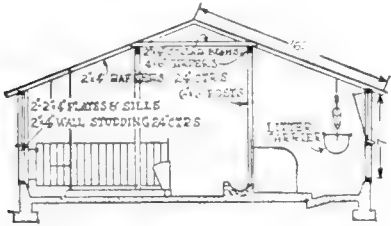

### MATERIAL LIST

- 2 Girders 18 ft. long by 4 by 6 in.
- 6 Posts 10 ft. long by 6 in. square.
- 2 Girders 22 ft. long by 4 by 6 in.

The following pieces of 2 by 4-in. stock will be required:

- 35 Pieces 12 ft. long
- 25 Pieces 14 ft. long
- 1200 Sq. ft. of 1 by 8-in. siding
- 1400 Sq. ft. of sheathing
- 14 Squares of roofing
- 50 Pieces 16 ft. long
- 17 Pieces 10 ft. long
- 15 Windows
- 40 Barrels of cement

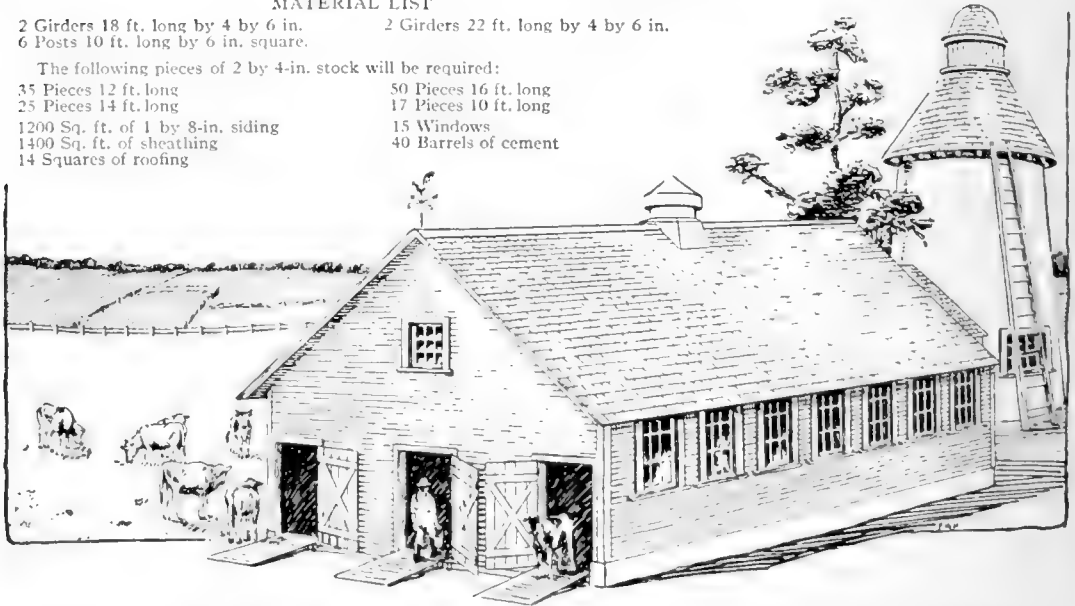

Plans of a small modern dairy barn that can be enlarged as the herd grows and finished inside whenever convenient. In a one-story structure hay may be stored in an adjoining shed

left unfinished on the inside temporarily and when the profits from the herd justify the expense it may be boarded and ceiled or plastered. The capacity of the barn may be increased at any time.

When making additions it must be remembered that there are certain standard material lengths and the structure should be planned in these lengths or their multiples to avoid waste in the cutting of the stock. This applies only to the woodwork. The concrete is laid on a well packed foundation

arrangements for feeding and barn cleaning. The estimated cost of the structure is about \$500 without the silo and the barn and stable equipment. It will cost \$1000 to build a two-story barn of this size to accommodate 25 tons of loose hay in addition to the stock; but the hay can be stored very nicely in a shed at the end of the barn at a cost of \$125. Where economy is an important factor, the one-story barn meets every requirement without sacrificing any of the features essential to cow comfort.





Q  
1  
P67  
v.89

Popular science monthly

Physical &  
Applied Sci  
Serials

**PLEASE DO NOT REMOVE  
CARDS OR SLIPS FROM THIS POCKET**

---

**UNIVERSITY OF TORONTO LIBRARY**

---

